



# LUND UNIVERSITY

## Warm Sheet Metal Forming with Localized In-Tool Induction Heating

Larsson, Linus

2005

[Link to publication](#)

*Citation for published version (APA):*

Larsson, L. (2005). *Warm Sheet Metal Forming with Localized In-Tool Induction Heating*. [Licentiate Thesis, Department of Mechanical Engineering Sciences].

*Total number of authors:*

1

### General rights

Unless other specific re-use rights are stated the following general rights apply:

Copyright and moral rights for the publications made accessible in the public portal are retained by the authors and/or other copyright owners and it is a condition of accessing publications that users recognise and abide by the legal requirements associated with these rights.

- Users may download and print one copy of any publication from the public portal for the purpose of private study or research.
- You may not further distribute the material or use it for any profit-making activity or commercial gain
- You may freely distribute the URL identifying the publication in the public portal

Read more about Creative commons licenses: <https://creativecommons.org/licenses/>

### Take down policy

If you believe that this document breaches copyright please contact us providing details, and we will remove access to the work immediately and investigate your claim.

LUND UNIVERSITY

PO Box 117  
221 00 Lund  
+46 46-222 00 00

# Warm Sheet Metal Forming with Localized In-Tool Induction Heating

- A survey of existing knowledge and an introduction to a new process



LUND UNIVERSITY

*Linus Larsson*

Production and Materials Engineering  
Lund University  
October 2005

Production and Materials Engineering  
Faculty of Engineering, Lund University  
P.O. Box 118  
S-221 00 LUND  
Sweden

CODEN: LUTMDN/(TMMV-1060)/1-84/(2005)  
©2005 by Linus Larsson and Production and Materials Engineering.  
All rights reserved

## Abstract

The increasing use of light metals and high strength steel in the automobile industry, demands for new sheet metal forming processes that can be applied successfully. In this thesis the subject of *warm sheet metal forming* is studied.

In warm sheet metal forming the temperature of the blank is elevated either globally to one temperature evenly over the blank or locally where the flange region of the blank is given a higher temperature. A survey of existing knowledge on the subject shows that the formability can be improved remarkably. This is especially true for the deep drawing of aluminum alloys and magnesium alloys. Other benefits can also be found like the elimination of stretcher-strain marks, which can be found on certain aluminum alloys, and reduction of springback.

The temperature of the blank is usually elevated by using heated tools that warm the blank through conduction. The tools are usually heated by utilizing electrical resistance heaters inserted at different locations into the tool. If the flange region is to be given a higher temperature the use of a heated blank holder and die can be used in conjunction with a cooled punch. In the thesis a new heating process is described called *Localized In-Tool Induction Heating*. The process integrates induction heating into the forming tool in such a way that a locally heated blank can be obtained. A short pre-heating time can then be followed by continual heating during the stroke. Since the blank is warmed, without heating the different parts of the tool, a fast and efficient process can be expected. A case study has been conducted where the manufacturing performance of *Warm Sheet Metal Forming with Localized In-Tool Induction Heating* has been compared with traditional sheet metal forming of a car trunk lid in aluminum.

In the thesis it is concluded that warm sheet metal forming has a great potential, but the processes used must be further developed to meet production demands. A new process has been introduced and future research will further develop the process.



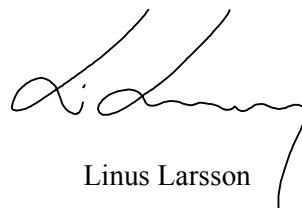
## Preface

This thesis gives a review on the topic of warm sheet metal forming as well as it introduces a new forming process with a concept called Localized In-Tool Induction Heating. The research has been carried out under the supervision of Professor Jan-Eric Ståhl at Production and Materials Engineering, Lund University. The research conducted and presented in this thesis is part of a larger project called Simuform. Simuform is one of the projects in the ProViking program that started in the year of 2003.

I would like to express my gratitude to Professor Jan-Eric Ståhl for giving me the opportunity to conduct my research and to ProViking for their financial support. I would also like to thank all my colleagues at Production and Materials Engineering, especially my assistant supervisors Assistant professor Mats Andersson and Adjunct professor Tord Cedell.

Finally I would like to thank Jenny, my family and my friends for always being there for me.

Lund, October 2005



Linus Larsson



# Contents

1 Introduction.....	1
1.1 Background .....	1
1.2 Objectives .....	1
1.3 Scope and limitation.....	2
1.4 Thesis outline .....	2
2 Warm Sheet Metal Forming – A Review .....	3
2.1 Introduction .....	3
2.2 Tensile properties .....	4
2.3 Tooling .....	17
2.4 Deep drawing trials .....	19
2.5 Stretch forming trials .....	24
2.6 Industrial trials.....	26
2.7 Lubrication .....	28
2.8 Springback.....	30
2.9 Forming limit curves .....	32
2.10 Numerical modeling.....	34
2.11 Discussion and Conclusions .....	36
3 Concepts of Warm Sheet Metal Forming .....	39
3.1 Introduction .....	39
3.2 Globally heated blank .....	41
3.2.1 External heating.....	44
3.2.2 Internal heating through conduction .....	44
3.2.3 Combined heating.....	44
3.3 Locally heated blank .....	45
3.3.1 Internal heating and cooling through conduction.....	46
3.3.2 Internal heating in cold tool.....	47
3.4 Discussion and Conclusions .....	47
4 Localized In-Tool Induction Heating .....	49
4.1 Introduction .....	49
4.2 Process description.....	49
4.3 Induction heating system .....	52
4.3.1 Introduction .....	52



4.3.2 Theoretical background .....	52
4.3.3 Induction coil.....	54
4.3.4 Flux concentrator.....	55
4.3.5 Phase advancing/resonance capacitor.....	55
4.3.6 Step-down transformer .....	56
4.3.7 Switched mode power electronics .....	56
4.4 Tool integration .....	56
4.5 Discussion and Conclusions .....	58
<b>5 Process Potential: A Case Study .....</b>	<b>59</b>
5.1 Introduction .....	59
5.2 The Manufacturing Performance Matrix (MPM).....	59
5.2.1 Process Parameters .....	60
5.2.2 Factor groups.....	60
5.2.3 Matrix.....	61
5.3 Case Study.....	63
5.4 Discussion and Conclusions .....	68
<b>6 Discussion and Conclusions.....</b>	<b>69</b>
<b>7 Further Research .....</b>	<b>71</b>
<b>References.....</b>	<b>73</b>

# **1 Introduction**

## **1.1 Background**

The manufacturing of mass-produced parts from sheet metal can be found in a variety of industries. Sheet metal forming processes are used to manufacture everything from simple inexpensive household utensils to large aerospace structures. In many cases the automobile industry plays a key role in the development of new materials and processes because of the large amount of sheet metal parts used. Low weight is desirable for a car, not at least because of the regulations on exhaust emissions that the manufacturers are faced with. The use of light metals has become more and more common. Today complete cars are being made from aluminum alloys and also magnesium alloys are beginning to find its way into the car industry. Steels with higher strengths allowing a thickness reduction and thus lower weight are also more commonly used.

Compared to ordinary mild steel, the materials mentioned above are all more difficult to form. Besides the lower formability, aluminum and high strength steels also exhibit a large springback. Some aluminum alloys exhibit so called stretcher-strain marks on the surface and can therefore not be used for visible outer panels because of the high quality demands on the surfaces. To overcome the formability issue and in some extent the springback and the stretcher-strain marks on aluminum alloys warm sheet metal forming can be used. In warm sheet metal forming the temperature of the sheet is elevated and a more beneficial sheet metal forming process is obtained.

## **1.2 Objectives**

Warm sheet metal forming has been studied extensively through the years and one of the objectives with this thesis is to provide a state of the art on the subject. Furthermore a new warm sheet metal forming process has been developed and this process is presented and discussed. The objective is to create a base from which the process can be further developed.

### **1.3 Scope and limitation**

The state of the art on the subject of warm sheet metal forming is not limited to any certain group of alloys, but the main focus lies on aluminum and magnesium alloys. Steel, titanium and stainless steel are also studied to some extent.

No experimental work on the new warm sheet metal forming process are presented in the thesis, but will be presented in future publications.

### **1.4 Thesis outline**

The thesis starts with a review which provides a state of the art on the subject of warm sheet metal forming. Different main concepts and a new warm sheet metal forming process is presented and discussed in the subsequent chapters as well as a case study where the potential of the process is evaluated. Suggestions for future research conclude the thesis.

## 2 Warm Sheet Metal Forming – A Review

### 2.1 Introduction

When discussing forming at elevated temperature it is important to distinguish warm forming from hot forming. In warm forming the microstructure is basically stable, but in hot forming microstructural changes occur, including recrystallization and grain growth. Usually the temperature interval for warm forming starts at 0.3 times the melting temperature and ends at 0.5 times the melting temperature. At higher temperatures the term hot forming is used.

As this review will show, warm sheet metal forming can be conducted either with a homogeneous heated blank or with a blank that is only heated partially. These two different concepts obtain the possible advantage of increased formability in different ways and this is further discussed in a subsequent chapter.

This review primarily treats warm sheet metal forming of aluminum and magnesium, but comprises also steel, titanium and stainless steel to some extent.

The plastic deformation of metals takes place by one of two processes, slip and twinning, out of which slip is the most common. Slip occurs due to the movement of dislocations and thus the mobility of the dislocations plays a key role in the ease of deformation. As the dislocations move through the lattice, an applied stress is required to overcome the lattice friction. This friction stress is often referred to as the Peierls-Nabarro stress. Thermal energy aids the dislocations to overcome these stresses. In bcc metals, like steel, Peierls-Nabarro stresses are the main obstacle and the temperature dependence is thus strong, but in fcc metals, like aluminum, the temperature dependence is weaker [30].

Magnesium, which has a hexagonal crystal structure, has a very low formability at room temperature, but at higher temperatures the formability increases drastically. At room temperature deformation takes place by slip on the basal planes and by twinning on the pyramidal  $\{1012\}$  planes, but above about  $250^{\circ}\text{C}$  slip also occurs on the pyramidal  $\{1011\}$  planes, twinning becomes less important, and plastic deformation can occur much easier [31].

## 2.2 Tensile properties

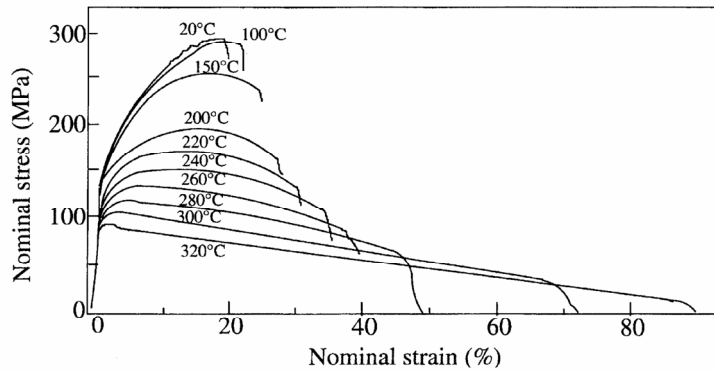
Many frequently used mechanical properties are obtained from the uniaxial tensile test. Although the properties obtained, like uniform elongation and ultimate tensile strength, do not give a good measurement of the materials ability to be shaped, i.e. the formability of the material, they do give information about the materials potential in biaxial tension. Because of this, and because the tensile test is easy to perform, tensile tests at elevated temperatures play an important role in understanding a materials behavior in warm sheet metal forming.

A number of problems arise when the tensile test is conducted at elevated temperatures. Matters such as temperature measurement, clamping of the specimen, strain measurement and balancing times to reach an even temperature distribution in the specimen all influences the results [1].

There have been numerous studies published on the tensile properties at elevated temperatures of aluminum alloys. Aluminum alloys can be divided into heat treatable and non-heat treatable alloys and these two groups of alloys has different warm forming capabilities.

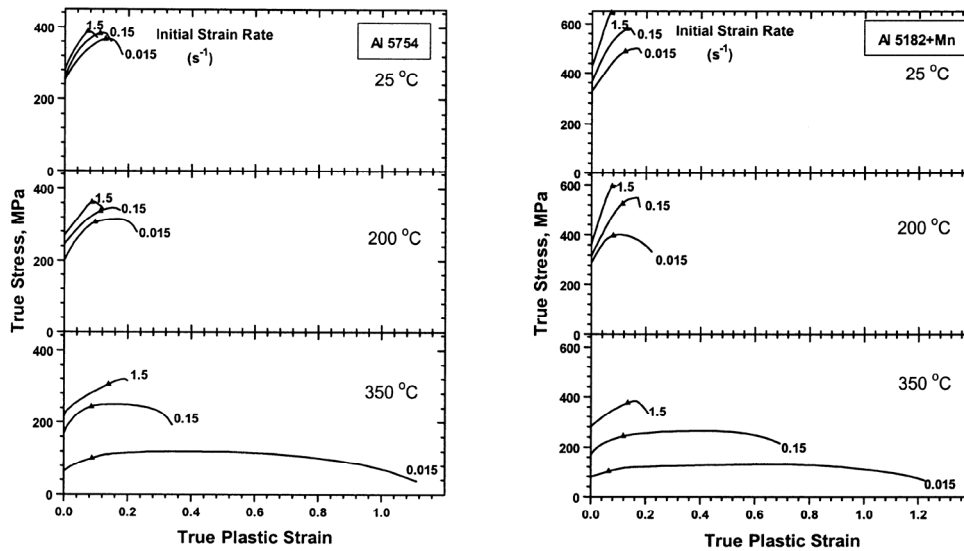
Non-heat treatable Al-Mg alloys have been studied extensively [1,4,5,6,8,9,18,20,21,22,35,36,37,38]. In general, these studies indicate that the yield strength and the tensile strength decrease with increasing temperature. Furthermore the uniform elongation decreases but the total elongation increases. Consequently the increase in total elongation is obtained because of a significant increase in post-uniform elongation. It can also be seen that the strain hardening exponent decreases with increasing temperature.

Naka & Yoshida [5] performed tensile tests with alloy 5083-O at a wide range of strain rates (from  $5.56 \times 10^{-5} \text{ s}^{-1}$  up to  $52.9 \text{ s}^{-1}$ ). Both Ayres & Wenner [6] and Takuda et al. [9] have studied alloy 5182-O. Figure 2.1 shows the engineering stress-strain curves for this alloy and in the figure the relation between the tensile properties and temperature can clearly be seen. Morris & George [20] also studied 5083-H14 and 5182-H14. They conclude, based on tensile testing, that the optimum forming temperature for these alloys is about  $250^\circ\text{C}$ .



**Figure 2.1:** Engineering stress-strain curves for 5182-O, sheet thickness 1.0 mm [9].

Li & Ghosh [21] studied the non-heat treatable alloy 5754-O. They also studied a modified 5182-O with an addition of about 1% Mn called 5182+Mn. The addition of Mn was aimed at enhancing the strain rate sensitivity of the flow stress. Figure 2.2 shows the true stress-true plastic strain curves for the two alloys at three different strain rates and temperatures.

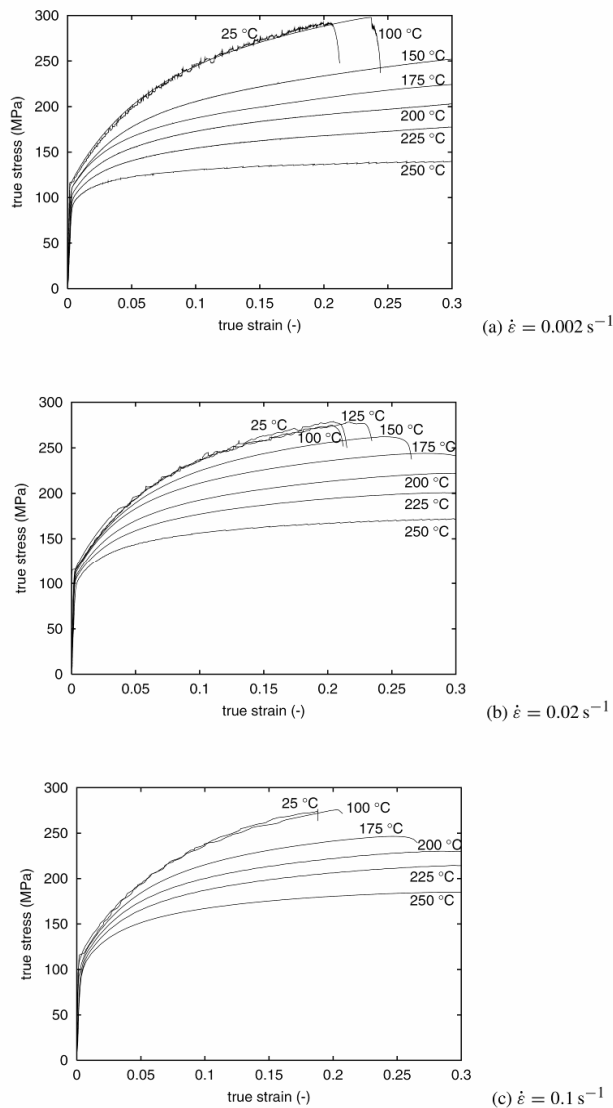


**Figure 2.2:** True stress-true plastic strain curves for aluminum alloys 5754-O and 5182+Mn-O. The position of maximum load is indicated by a ▲ [21].

Boogaard [37] performed tensile tests with the alloy 5754-O. He used 1.2 mm thick specimen with an initial gauge length of 50 mm. The specimen and clamps were

placed in a furnace capable of 250°C. Uniaxial tensile test were performed at different temperatures and strain rates at the true stress-strain curves can be seen in Figure 2.3.

As can be seen in Figure 2.1 to Figure 2.3 the yield strength and the tensile strength decreases with increasing temperature. It can also be seen that the uniform elongation decreases, but the total elongation increases and that the strain hardening exponent decreases with increasing temperature. The large influence of the strain rate can be seen as well.

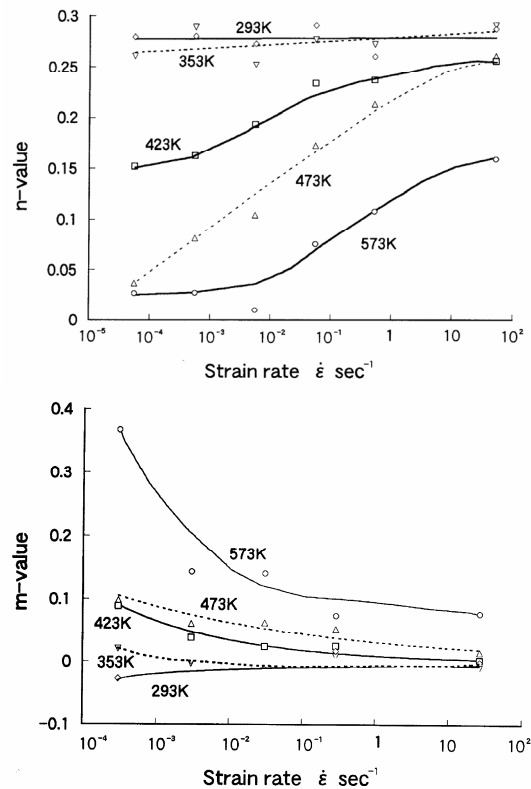


**Figure 2.3:** True stress-strain curves of 5754-O [37].

A low strain hardening exponent usually implies poor formability. The decrease of the strain hardening exponent with increasing temperature is compensated though by the strain rate hardening effect, which becomes more pronounced with increasing temperature [7]. Among the stress-strain relationships that take into account, apart from strain, also the rate of strain, the constitute equation

$$\sigma = K \varepsilon^n \dot{\varepsilon}^m \quad (1.1)$$

proposed by Backofen [39], is often used. In this equation  $n$  is the strain hardening exponent and  $m$  is the strain rate hardening exponent. Figure 2.4 shows how the strain hardening exponent and strain rate hardening exponent varies with strain rate and temperature. Naka et al [8] concluded that the improvement in formability at 300°C at low forming speed is specifically due to the high strain rate hardening, but below 200°C the formability is also strongly affected by strain hardening.



**Figure 2.4:** Effect of strain rate and temperature on strain hardening exponent ( $n$ ) and strain rate hardening exponent ( $m$ ) of 5083-O, sheet thickness 1.0 mm [8].



Li & Ghosh [21] show the  $n$ - and  $m$ -values vs. temperature for the two non-heat treatable alloys in their studies, see Figure 2.5. The figure also shows one heat treatable alloy (6111-T4).

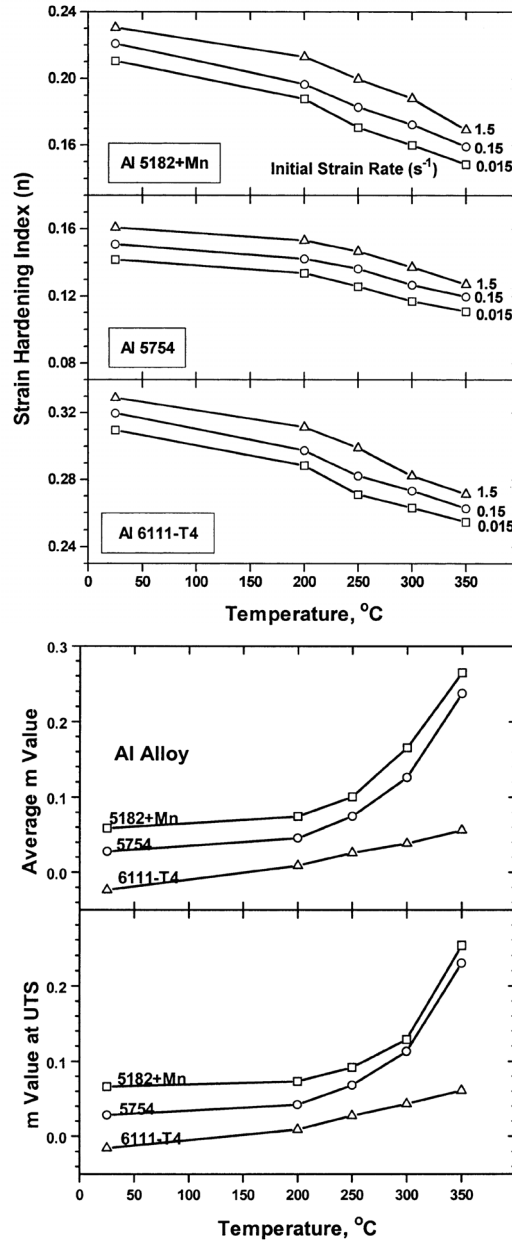


Figure 2.5: Strain hardening exponent ( $n$ ) and strain rate hardening exponent ( $m$ ) vs. temperature [21].

The relationship between the strain hardening and the strain rate hardening is fundamental for understanding sheet metal forming at elevated temperature and will be further discussed in a subsequent chapter.

If the properties of a material depend on direction the material is said to be anisotropic and this is often the case with sheet metal. The state of anisotropy is often indicated by the  $R$ -value defined as

$$R = \frac{\varepsilon_w}{\varepsilon_t} \quad (1.2)$$

where the  $\varepsilon_w$  is the strain in the width direction and  $\varepsilon_t$  the strain in the thickness direction of a tensile test sample. As a comparative value, the normal anisotropy parameter  $\bar{R}$  defined as

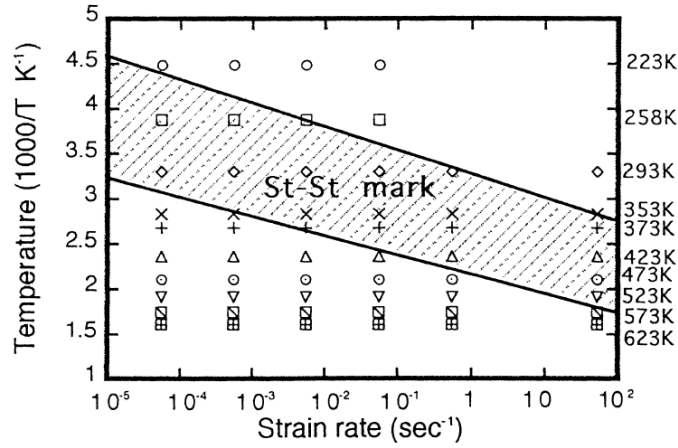
$$\bar{R} = \frac{R_0 + 2R_{45} + R_{90}}{4} \quad (1.3)$$

where the rolling direction is indicated by the subscript can be used. This value has an important meaning in deep drawing since it indicates the materials “resistance” to thinning. In tensile tests of the aluminum alloy 5082-O performed at elevated temperature the normal anisotropy parameter  $\bar{R}$  is reported to be almost independent of temperature [6,9].

Shetata et al. [4] examined the effect of magnesium content by performing tensile tests with Al-Mg alloys containing between 0 and 6.6% magnesium at temperatures ranging from 20°C to 300°C at low strain rates. Three different tempers for each composition were tested, one annealed and two cold rolled to different extents. Their results indicate that both the ductility and the strength increase with increasing magnesium content at all temperatures. It is also concluded that at high temperatures the hardest temper shows higher elongation to fracture than the softer tempers, which is opposite to the behavior at low temperatures. Ayres [26] has also examined the effect of magnesium content by performing tensile tests and in his study it is also concluded that the ductility increases with magnesium content at warm forming temperatures.

On the surface of Al-Mg alloy sheets undesired stretcher-strain marks may appear. Stretcher-strain marks are generated as a result of non-uniform plastic deformation induced by dynamic strain aging (the Portevin-Le Chatelier effect) at certain strain rates and temperatures. A suitable combination of temperature and strain rate therefore eliminates these stretcher-strain marks. The strain rate hardening exponent is an important parameter here since a negative  $m$  is a necessary condition for the Portevin-Le Chatelier effect to take place. Figure 2.6 shows the

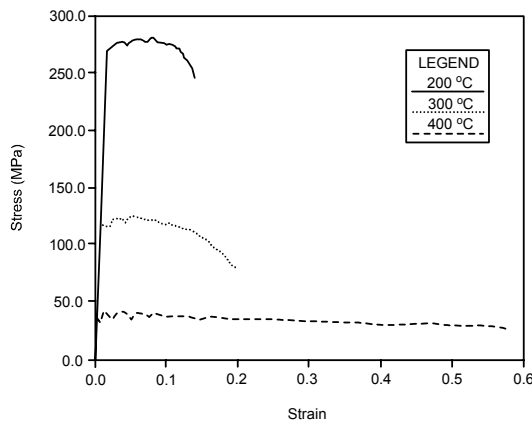
appearance of stretcher-strain marks in the temperature versus strain rate diagram for 5083-O.



**Figure 2.6:** Condition of temperature and strain rate for the appearance of stretcher-strain marks [5].

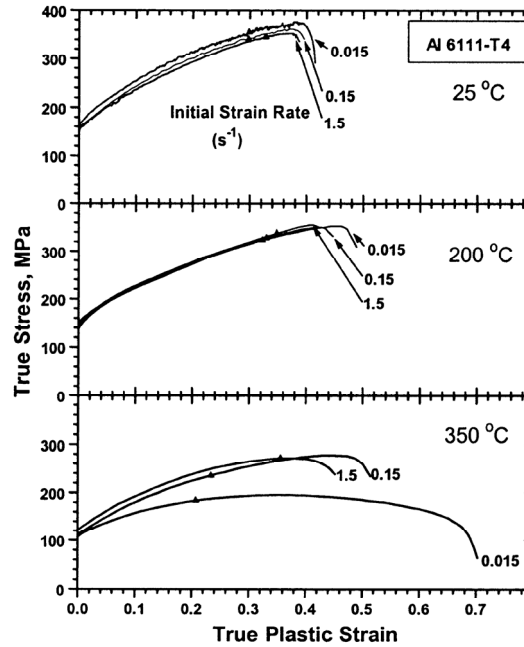
This is also illustrated in Figure 2.3 where typical serrations of the Portevin-Le Chatelier effect are present at lower temperatures, but not at temperatures of 150 °C and higher [37].

There are some studies done on heat treatable aluminum alloys [17,18,20,21,36]. Fuchs & Williams [17] have done a study on strain measurement at elevated temperatures and high strain rates, testing the Al-Mg-Si alloy 6061-T6. Figure 2.7 shows the engineering stress-strain curves for the alloy at an effective strain rate of  $0.8 \text{ s}^{-1}$ .



**Figure 2.7:** Engineering stress-strain curves for 6061-T6 at an effective strain rate of  $0.8 \text{ s}^{-1}$  [17].

Li & Ghosh [21] studied 6111-T4. The true stress-true plastic strain curves for the alloy are given in Figure 2.8.



**Figure 2.8:** True stress-true plastic strain curves for aluminum alloy 6111-T4. The position of maximum load is indicated by a ▲ [21].

Morris & George [20] studied, besides the non-heat treatable alloys mentioned before, the heat treatable alloys 6061-T6, 7046-T6 and 7029-T6. They conclude, based on tensile testing, that the optimum forming temperature for these alloys is about 200°C. They further conclude that these alloys would not expect to perform well in stretch forming because of the low strain rate hardening that they exhibit.

Taylor et al. [18] have studied both heat treatable aluminum alloys (2036-T4, 5020-T4, 6151-T4) and non-heat treatable aluminum alloys (5085-H111, 5090-H34, 5182-O). They conclude (based on tensile test data) that the potential advantages of warm forming the heat treatable alloys are very slight. The non-heat treatable alloys show more potential, but need to be further examined in actual forming tests at production strain rates [18].

The conclusion that non-heat treatable aluminum alloys show more potential in warm forming than heat treatable aluminum alloys is also supported by Li & Ghosh [21].

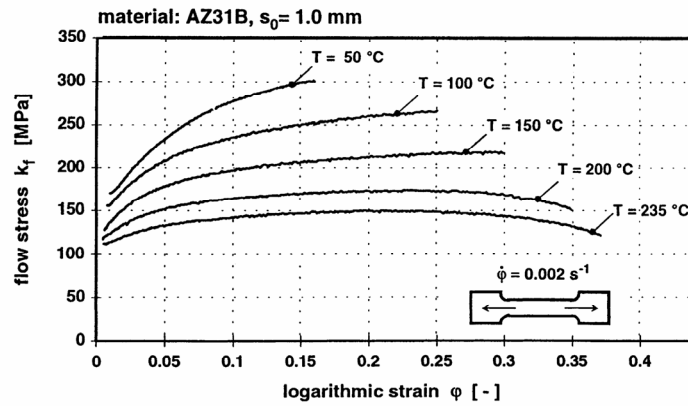
With heat-treatable aluminum alloys it is important to avoid temperatures causing recrystallization or over-aging. The temperatures must therefore be chosen carefully so that it is high enough to increase formability, but low enough to avoid a loss in final strength.

Table 2.1 below summarizes where tensile data at elevated temperature for different aluminum alloys can be found.

*Table 2.1: References where tensile data can be found.*

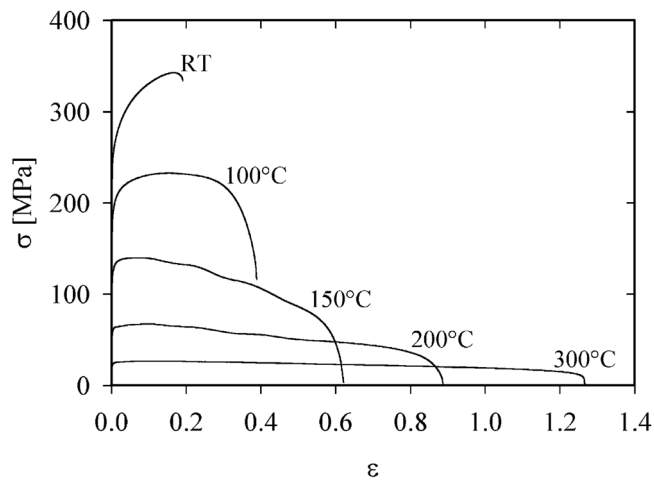
<b>Aluminum alloy</b>	<b>Reference</b>
2036-T4	18
5020-T4	18
5052-O	38
5083-H14	20
5083-O	5,8
5085-H111	18
5090-H34	18
5182+Mn-O	21
5182-H14	2
5182-O	1,6,9,18
5754-O	21,35,36,37
6016-T4	36
6061-T6	17,20
6111-T4	21
6151-T4	18
7029-T6	20
7046-T6	20
AlMg2	4
AlMg4.4	4
AlMg6.6	4
AlMg6.8-O	22

As mentioned in the introduction elevated temperature has a large influence on the formability of magnesium alloys. Flow curves for temperatures ranging from 25°C to 250°C for a number of magnesium alloys are given in [2]. Doege et al. [3] have done similar investigations and in Figure 2.9 the flow curves of magnesium sheet material AZ31B for different temperatures are shown. It can be seen that the tensile strength and the strain hardening exponent decreases with increasing temperature. The elongation to fracture increases with increasing temperature.



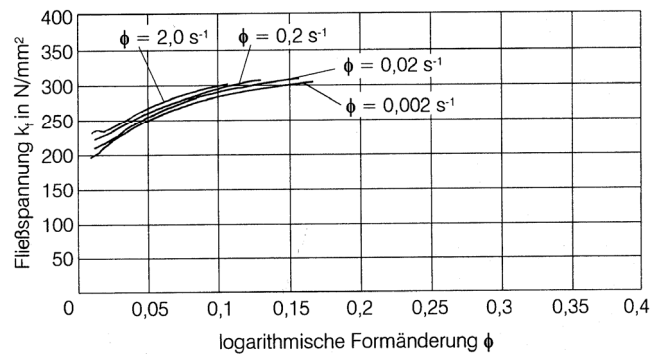
**Figure 2.9:** Flow curves for AZ31B, sheet thickness 1.0 mm, strain rate  $0.002 \text{ s}^{-1}$  [3].

Figure 2.10 also shows true stress-strain curves for AZ31B [40]. The strain rate is much lower than in the tests performed by Doege et al. [3] and the notable difference points out how important strain rate is.

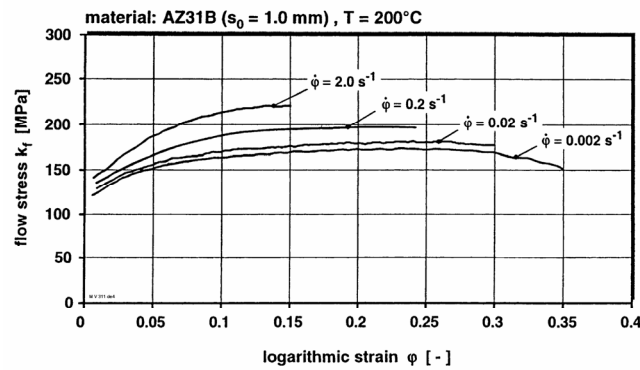


**Figure 2.10:** True stress-strain curves for AZ31B-H24, strain rate  $0.00013 \text{ s}^{-1}$  [40].

The influence of strain rate on the flow curves is important when trying to understand how the material will behave in sheet metal forming. Doege et al. [3] concluded that a raise of strain rate from  $0.002 \text{ s}^{-1}$  to  $2.0 \text{ s}^{-1}$  leads to a considerable increase in flow stress at high temperature, but is less significant at lower temperature. Studying Figure 2.11 and Figure 2.12, showing the influence of strain rate at  $25^\circ\text{C}$  and at  $200^\circ\text{C}$  respectively, this clearly can be seen.



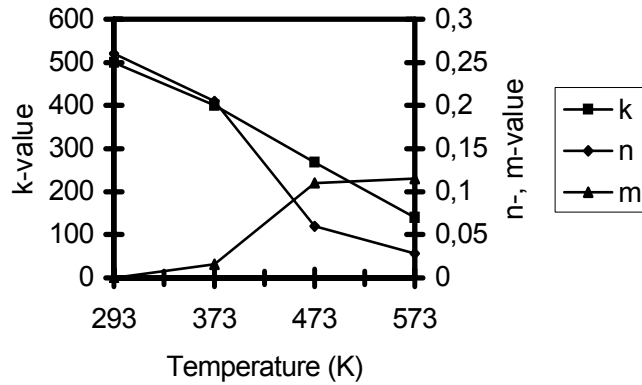
**Figure 2.11:** Flow curves for AZ31B at room temperature, sheet thickness 1.3 mm, for different strain rates [2].



**Figure 2.12:** Flow curves for AZ31B at 200°C, sheet thickness 1.0 mm, for different strain rates [3].

AZ31B is the most investigated alloy, but tensile test data at elevated temperature for the magnesium alloys AZ61B and MN150 can be found in the Ph. D. thesis of Dröder [43].

El-Morsy & Manabe [23] have made tensile tests with AZ31-O at four different temperatures and at three different crosshead speeds. The properties  $k$ ,  $n$  and  $m$  were determined and are given in Figure 2.13. As can be seen the  $n$ - and  $m$ -values follows the expected trend, but much more pronounced between 100°C and 200°C than at higher temperatures.



**Figure 2.13:** Material properties  $k$ ,  $n$  and  $m$  for AZ31-O [23].

The use of ordinary steel sheet in the warm forming temperature range is very limited due to the small temperature influence on the forming properties. Hot forming of steel is much more favorable and can be accomplished successfully. A number of studies on stainless steel though show that the material can be used in warm forming and the tensile properties at elevated temperatures from some studies are reviewed below.

Lee et al. [27] have made tensile tests at temperatures ranging from room temperature up to 300°C for a SCP1 (ordinary mild steel) sheet. The chemical composition for the material is given in Table 2.2 and the various material properties obtained are shown in Table 2.3.

**Table 2.2:** Chemical composition of SCP1 steel sheet [27].

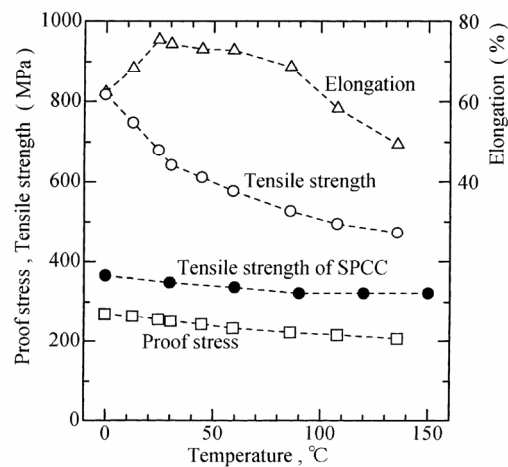
	C	N	Mn
SCP1	0.007	0.004	0.15

**Table 2.3:** Material properties for SCP1 steel sheet [27].

Temp. (°C)	Tensile strength (kgf/mm <sup>2</sup> )	Elongation	Strength coefficient	Strain hardening coefficient
R.T.	29.89	44.9	58.032	0.2493
50	29.55	43.7	56.804	0.2407
100	28.03	40.2	54.102	0.2429
150	26.62	37.9	50.810	0.2367
200	25.64	36.3	49.146	0.2372
250	23.98	35.3	46.405	0.2408
300	23.13	33.7	44.970	0.2330

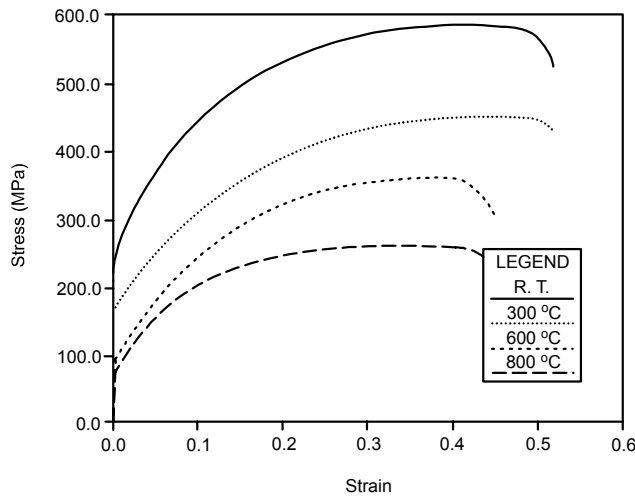


Figure 2.14 shows the tensile properties for the type 304 stainless steel obtained by uniaxial tensile tests at various temperatures made by Takuda et al. [29]. The tensile strength of a mild steel (SPCC) is also given. The figure shows that the tensile strength for the 304 stainless steel decreases much more than the tensile strength for the mild steel, which stays almost constant. The austenite in an austenitic stainless steel (as type 304) transforms to martensite during cold forming and this delays the onset of necking. The large elongation at low temperature for 304 stainless steel is due to this deformation-induced martensite. The martensitic transformation decreases with increasing temperature and consequently the elongation decreases with increasing temperature [29].



**Figure 2.14:** Tensile properties of the type 304 stainless steel sheet and tensile strength for a mild steel (SPCC) for various temperatures [29].

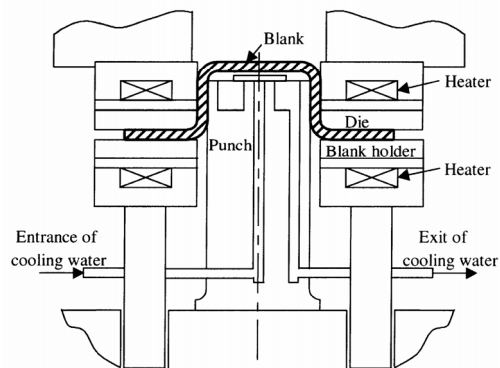
Figure 2.15 shows the engineering stress-strain curves for 304L stainless steel at higher temperatures (300°C, 600°C and 800°C) [17].



**Figure 2.15:** Engineering stress-strain curves for 304L stainless steel at an effective strain rate of  $0.8 \text{ s}^{-1}$  [17].

## 2.3 Tooling

The most common way of heating the blank is by letting a hot tool heat the blank through conduction. The tool is almost exclusively heated by electric resistance heaters inserted at different locations in the tool [3,5,8,10-15,27,36,41,42]. In some cases the punch is cooled by water or by air and only the die, and in some cases the blank holder, is heated [5,10,12-14,16,27,36,41,42]. Figure 2.16 shows a typical setup. The position of the heaters and the cooling of the punch are further discussed in chapter 2.4 to 2.6 below since this depends on the specific trial.



**Figure 2.16:** Schematic representation of experimental setup for warm deep drawing [29].

Taylor & Lanning [15] uses a heated tool, but they also heat the blank before placing it into the die. This is done by placing the blank between two large aluminum platens, heated by imbedded electric resistance heaters. Other ways of heating the blank is discussed and electric resistance heating is concluded to be a suitable process.

A heated die and blank holder combined with a cooled punch gives a temperature distribution in the blank. The use of a blank that is not uniformly heated is further investigated by Stalman e. al. [44]. They use a tool that is divided into temperature zones as Figure 2.17 describes combined with a cooled punch.

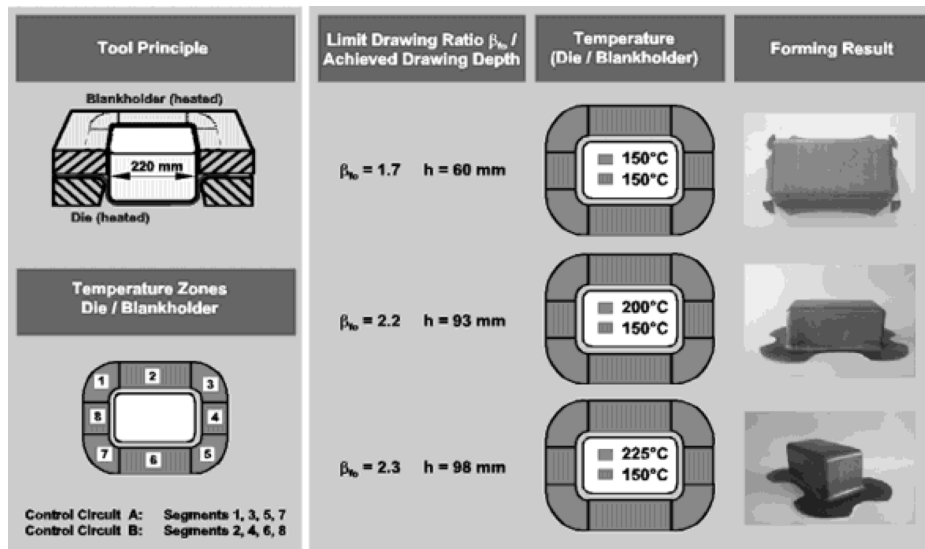
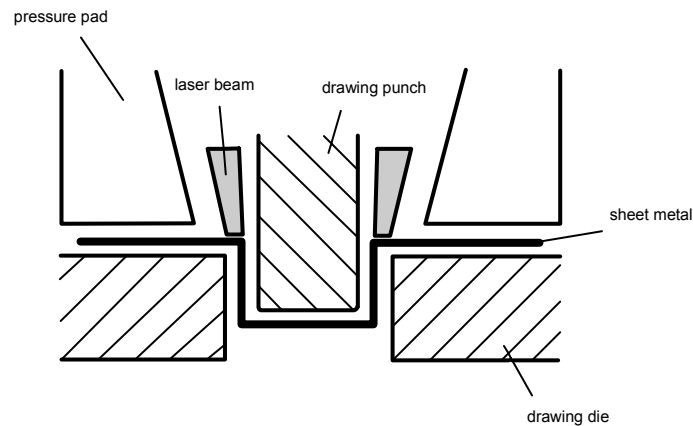


Figure 2.17: Tool divided into temperature zones [44].

Schuöcker & Schröder [24] have developed another technique to heat the sheet selectively during the forming process. The heating is performed by the irradiation of the sheet with a laser beam. The technique is called Laser Assisted Deep Drawing (LADD). The irradiation is established in the region of the die profile radius, reducing the yield strength of the sheet in this area (see Figure 2.18). The forces acting on the drawing punch and the blank holder are therefore reduced. When in addition the parameter setting of the process is selected in such a way, that recrystallisation processes can occur during the deep drawing process, the maximum logarithmic deformation increases, meaning that a higher drawing ratio can be admitted.



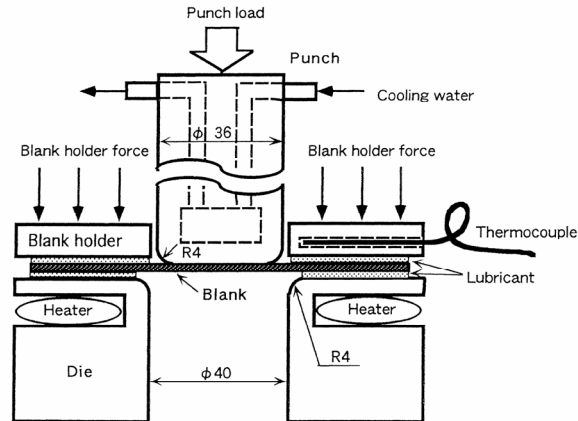
**Figure 2.18:** Laser assisted deep drawing [24].

## 2.4 Deep drawing trials

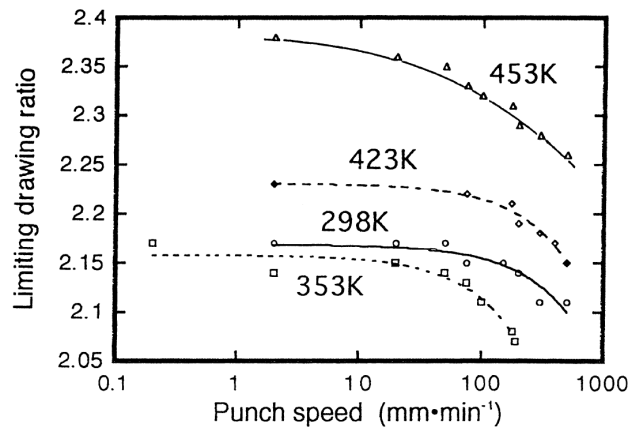
As early as 1946 Finch et al. [12,13] conducted thorough deep drawing trials with aluminum alloys at elevated temperatures, both with cylindrical cups and with boxes. In the deep drawing trials of cylindrical cups a large number of alloys were investigated, both heat treatable and non-heat treatable, and the effects of punch radius, die radius, clearance, hold-down load, die temperature and lubrication was studied. The die and the blank holder were heated with electric resistance heaters and the punch was cooled with water. The decision to use a cool punch instead of a heated is based on preliminary investigations revealing that greater draws were obtained with a cold punch. According to the authors this is due to the rapid cooling of the sidewalls of the cup as it is being drawn, thereby increasing their load carrying ability and permitting deeper draws. The specimens were kept for five minutes in the heated die to reach the desired temperature in the blank before drawing. It is concluded that the deep drawing properties of the aluminum alloys improved substantially with increasing temperature. It is also emphasized that a major factor is lubrication and that the use of suitable lubricants may provide even better results at elevated temperature [12]. Also in the case with boxes the deep drawing properties improved substantially with increasing temperature, both for the heat treatable and non-heat treatable alloys [13].

Naka & Yoshida [5] have made deep drawing trials with cylindrical cups at various punch speeds and temperatures. The alloy investigated is the Al-Mg alloy 5083-O. In their trials the die was heated (to temperatures ranging from 25°C up to 180°C) and the punch was cooled with water. Figure 2.19 shows the experimental setup and Figure 2.20 shows the limiting drawing ratio at different temperatures as a

function of punch speed. As can be seen from Figure 2.20 the deep drawability depends strongly on the die temperature and forming speed.



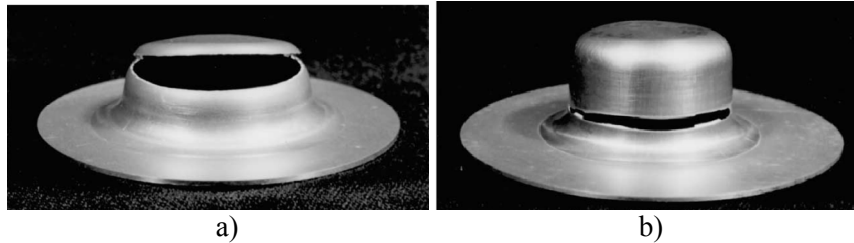
**Figure 2.19:** Schematic diagram of the experimental setup [5].



**Figure 2.20:** Effect of punch speed on the limiting drawing ratio at various die temperatures [5].

Moon et al. [14] have done similar deep drawing trials as Naka & Yoshida [5] with the aluminum alloy 1050. They cool the punch maintaining it at room temperature, but they also cool it further down to  $-10^{\circ}\text{C}$ . The die and blank holder is heated to temperatures ranging from  $25^{\circ}\text{C}$  up to  $200^{\circ}\text{C}$ . They conclude that the local strengthening of the punch nose radius by using a cold punch and the relaxation of strain concentration by using a heated die favors the deep drawability of the alloy investigated [14]. Figure 2.21 shows the difference in fracture types that occur

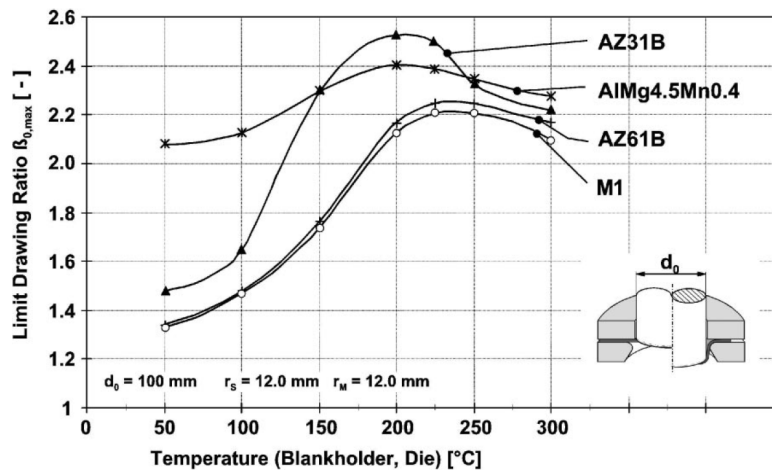
when using heated die & blank holder and a cooled punch compared to an ordinary trial at room temperature [9].



**Figure 2.21:** Fracture in the deep drawing test a) at room temperature for drawing ratio 2.4 and b) at 250°C (with a punch at room temperature) for drawing ratio 2.8 [9].

Bolt et al. [10] have done deep drawing trials with rectangular boxes. They use a cooled punch (to room temperature) and a die heated to 175°C. The alloys used are 5754-O, 6016-T4 and 1050-H14. It is concluded that the maximum height of the box, with a die at 175°C, is 20-25% larger than when drawn at room temperature.

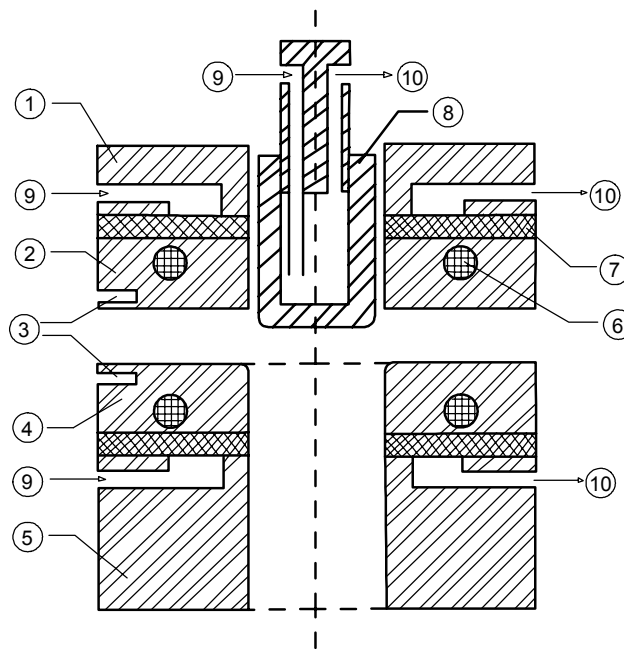
The magnesium alloys AZ31B, AZ61B and MN150 have been investigated by Doege & Dröder [3]. They used a setup with heated die, blank holder and heated or cooled punch. Figure 2.22 shows the limiting drawing ratio as a function of temperature. It is unclear if these results are obtained with a heated or an unheated punch. In Figure 2.22 the punch velocity is 5 mm/s, but trials are done with punch velocities up to 100 mm/s and it is concluded that the drawing velocity is very important. At 200°C the limiting drawing ratio for AZ31B drops from approximately 2.5 at 5 mm/s to 2.2 at 100 mm/s [3].



**Figure 2.22:** Temperature dependent limiting drawing ratios [3].

Stalman et. al. [44] uses a tool divided into different temperature zones as shown previously in Figure 2.17. Their basic idea is to increase the temperature in the magnesium alloy blank in the more severely formed areas. Their results indicate that formability can be increased by this manner.

The warm deep drawability of steel sheets has been examined by Lee et al. [27]. They used an experimental setup with heated die and blank holder and a cooled punch as shown in Figure 2.23. The punch, die and blank holder were Cr-coated. The drawing tests were done on an universal testing machine (UTM) at six different temperatures ranging from 25°C to 250°C using a forming velocity of 50 mm/min. The tool is square (60x60 mm) and square blanks made of 0.7 mm thick SCP1 steel sheets were used. Their results show that the drawing ratio (here meaning the ratio of the side length of the blank to that of the punch) can be increased from 2.4 at room temperature up to 2.8 at 250°C. The authors also conclude that the distribution of through-thickness strain is more uniform at elevated temperatures than at room temperature.



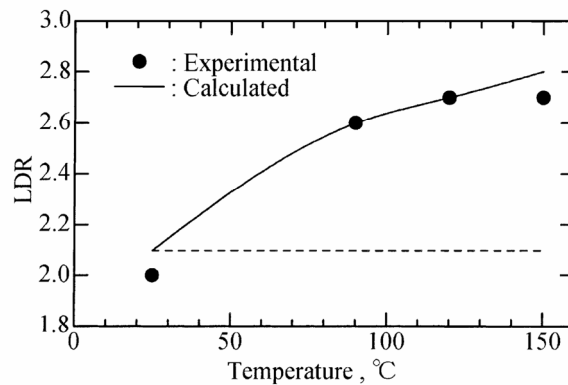
**Figure 2.23:** Schematic diagram of experimental setup including: 1. Holder cooling part, 2. Holder heating part, 3. Thermocouple, 4. Die heating part, 5. Die cooling part, 6. Heating pipe, 7. Insulation panel, 8. Punch, 9. Cooling water input, 10. Cooling water output [27].

Leighton & Lee [28] on the other hand reports that increasing the die temperature from 20°C to 125°C had little or no effect on sheet formability. Their experiments were done with aluminum-killed drawing quality (AKDQ) steel in a cylindrical

tool. They conclude though that using a punch cooled to between  $5^{\circ}\text{C}$  and  $10^{\circ}\text{C}$  and a room temperature die increases the limiting drawing ratio by 15%.

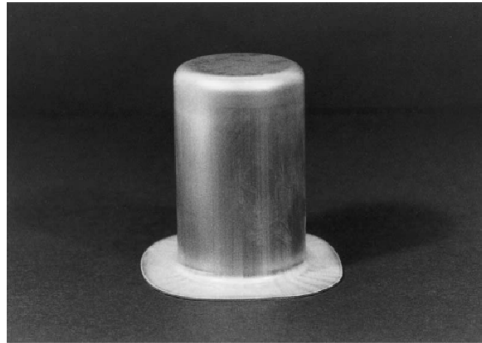
Kim et al. [25] have investigated the warm deep drawability of 304 stainless steel. Square cups were drawn with a cooled punch and die and blank holder heated up to  $210^{\circ}\text{C}$ . Both a crank press and a hydraulic press have been used and besides temperature the influence of press speed has also been examined. Their results show that the maximum drawing depth at  $120^{\circ}\text{C}$  reaches 1.4 times the drawing depth at room temperature in a crank press and 1.6 times in a hydraulic press at  $150^{\circ}\text{C}$ . Increasing the temperature above  $150^{\circ}\text{C}$  in a hydraulic press does not increase the drawing depth. In a crank press on the other hand the drawing depth decreases over  $120^{\circ}\text{C}$ .

Also Takuda et al. [29] have investigated the warm deep drawability of 304 stainless steel. Their tests were carried out from room temperature up to  $150^{\circ}\text{C}$  in a cylindrical tool. The die and the blank holder were heated while the punch was cooled by water. They conclude that the limiting drawing ratio becomes remarkably higher at higher temperature than at room temperature. Figure 2.24 shows the limiting drawing ratios as a function of temperature and Figure 2.25 shows a drawn cup.



**Figure 2.24:** Experimental and calculated limiting drawing ratios for type 304 stainless steel. The dotted line indicates the limiting drawing ratios calculated under the uniform temperature condition [29].





*Figure 2.25: Drawn cup at 120°C for drawing ratio 2.7 [29].*

Chang & Chou has made deep drawing trials of type 304 stainless steel with both a square-shaped tool [42] and with a cylindrical tool [41]. They use a cooled punch and call the process “two-temperature deep drawing”. Their studies direct towards the changes in microstructure that occur during forming at an elevated temperature.

Similar experiments as Chang & Chou performed with stainless steel [41] has been performed by Liu & Chou [45], but with a commercially pure titanium sheet (AMS 4901 grade 4). They performed deep drawing trials up to 400°C and they conclude that the deep drawability of the titanium alloy at that temperature is almost twice that at room temperature.

## 2.5 Stretch forming trials

Taylor & Lanning [15] have conducted stretch forming trials with a  $\phi 102\text{ mm}$  hemispherical punch on the Al-Mg alloy 5182-O. Temperatures ranging from room temperature to 300°C and three different punch velocities were used, where the highest punch velocity (300 mm/s) was selected to be comparable to production rate. A thin Teflon sheet was used as a lubricant. The maximum dome heights just before failure were measured and are given in Figure 2.26 as a function of forming rate. The appearance at low strain rates at the temperature of 300°C is explained by softening due to the long heat up time (two minutes) and testing time (one minute). It can be seen from the diagram that in order to improve the stretch formability at production rate the temperature must be increased sufficiently.

Similar stretch forming trials have been done by Shetata et al. [4] with AlMg2 (at low punch speeds though). They also report a large increase in maximum cup height compared to room temperature.

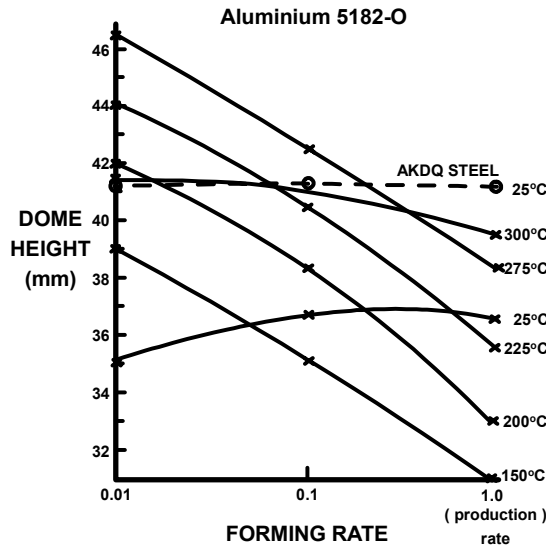


Figure 2.26: Maximum dome height versus forming rate [15].

Dröder & Janssen [11] have made stretch forming trials with a number of magnesium alloys. They used a setup with heated die, blank holder and punch. Their investigations are done at three temperatures, 150°C, 200°C and 250°C and their results are shown in Figure 2.27. Unfortunately the limiting dome heights at room temperature are not given. These results indicate that the alloy MN150 has the most pronounced temperature dependency and that the aluminum alloy and the magnesium alloy AZ31B are comparable over the investigated temperature range.

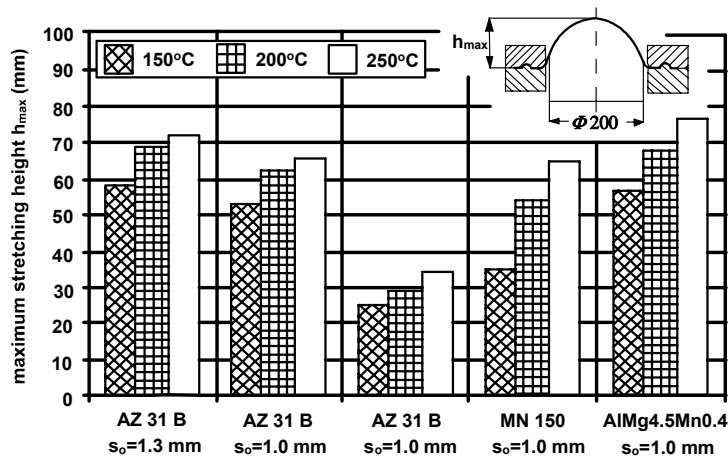


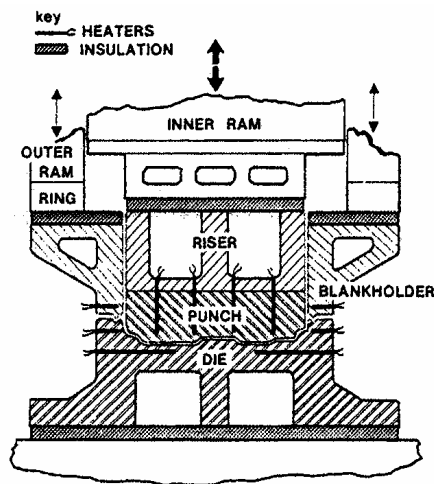
Figure 2.27: Maximum dome height for different sheet materials and temperatures [11].

## 2.6 Industrial trials

The trials described in chapter 2.4 and 2.5 are all more or less performed on simple geometries and they give important information about the performance of the process studied. It is important though to also study geometries and setups that are more close to how the process can be used commercially. The studies of this kind that can be found in the literature will be reviewed in this chapter.

Ayres et al. [16] made trials with an oil pan in aluminum alloy 5182-O at the production rate of approximately 10 strokes/minute. The forming operation was carried out on a die that was heated with electric heating pads bonded to the die and blank holder. Closing the tool and letting the hot air inside the die heat the punch by convection heated the punch. The blank was heated to a temperature 15-20°C warmer than the punch before placing it into the die. The tool was originally built for ordinary draw quality steel and the drawbead height had to be reduced to suit the process. Successful stampings at an average press rate of 10 strokes/minute was made at a temperature of 180 to 200°C.

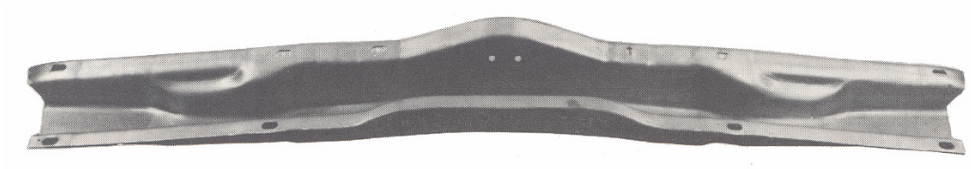
A door inner panel was successfully warm formed in 5182-O at full press rate by Taylor et al. [15]. The die, punch and blank holder was heated to 250°C by electric resistance heaters inserted at different locations in the tool, see Figure 2.28. The blank was heated before placing it into the die as described in chapter 2.3.



*Figure 2.28: Schematic cross-section showing location of heaters [15].*

Morris & George [20] have made forming trials with a car bumper, i.e. a bumper reinforcement, a bumper facebar, a bumper absorber center mounting bracket and a bumper guard. The bumper reinforcement and the mounting bracket can be seen in

Figure 2.29 and in Figure 2.30 respectively. The blanks were heated (using IR heat) to the desired temperature and then stamped in a cool tool. Because of the heat loss to the cold tool the blanks had to be heated to a higher temperature than actually desired.

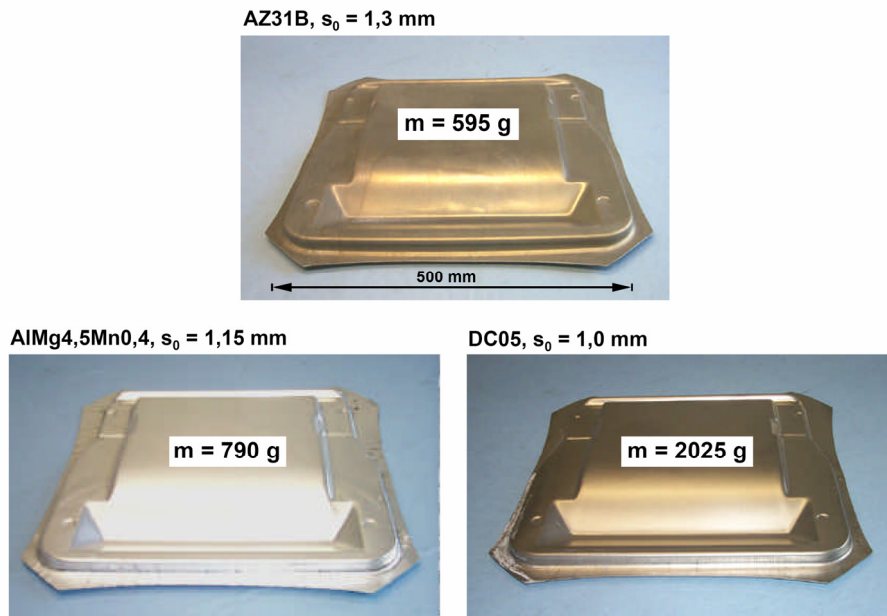


**Figure 2.29:** Bumper reinforcement formed from 7046-T6 at elevated temperature [20].



**Figure 2.30:** Front bumper absorber center mounting bracket formed from 5083-H14 at 250°C [20].

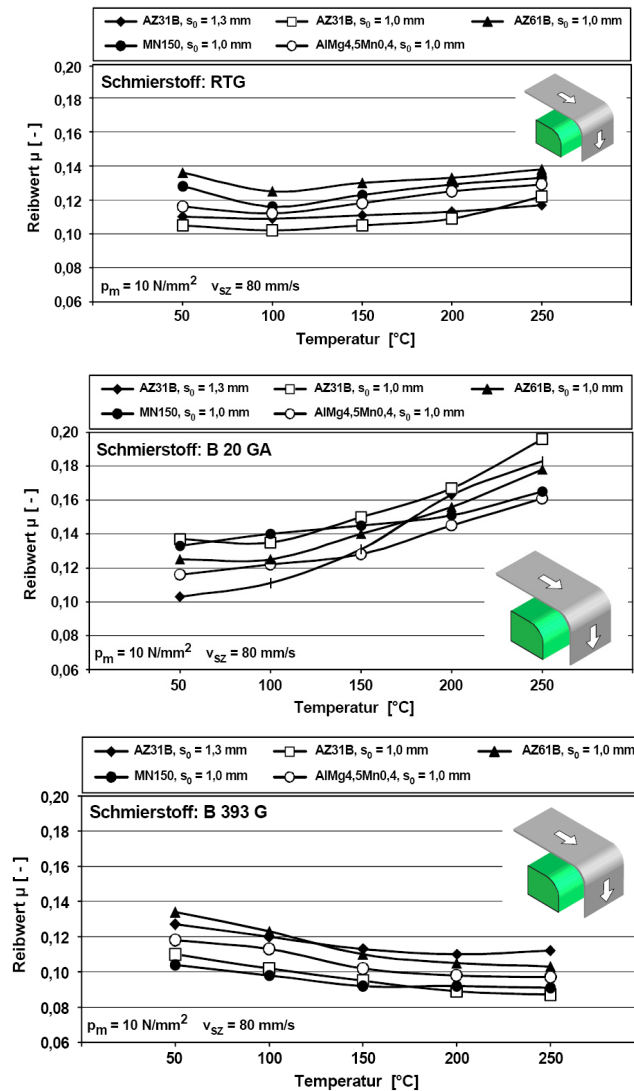
An automobile seat floor pan was made both from an aluminum alloy (AlMg4.5Mn0.4) and from the magnesium alloy AZ31B by Dröder [43]. The tool used was originally constructed for 1.0 mm thick steel sheet, but was modified with electric resistance heaters. At 250°C it was possible to produce the detail without any tears in the critical areas. Figure 2.31 shows the formed parts in steel (ordinary cold sheet metal forming), aluminum and magnesium.



*Figure 2.31: Automobile seat floor pan warm formed at 250°C from magnesium alloy sheet and from aluminum alloy sheet compared to ordinary cold sheet metal forming in steel sheet [43].*

## 2.7 Lubrication

Dröder [43] investigated three different lubricants in deep drawing trials at elevated temperatures with three different magnesium alloys and one aluminum alloy. The lubricants investigated are “RTG” which is a graphite paste, “B 393 G” which is a water-soluble full-synthetic lubricant and “B20 GA” which is a mineral oil based lubricant. He also determined temperature dependent friction values in a strip drawing test. Figure 2.32 shows the frictional values as a function of temperature.



**Figure 2.32:** Temperature dependent friction values for three different lubricants and different magnesium and aluminum alloys [43].

A lubricant consisting of graphite suspended in a polymer matrix (MB-503 from H. A. Montgomery Company) was used for their trials with an aluminum alloy by Ayres et al [16]. They report that the lubricant performed satisfactory.

Shehata et al [4] used a PTFE film in their experiments with aluminum alloys. PTFE was also used by Taylor & Lanning [15], and although several other lubricants were tested no one worked satisfactorily. It is concluded though that PTFE is not an alternative in running production because of the high cost.

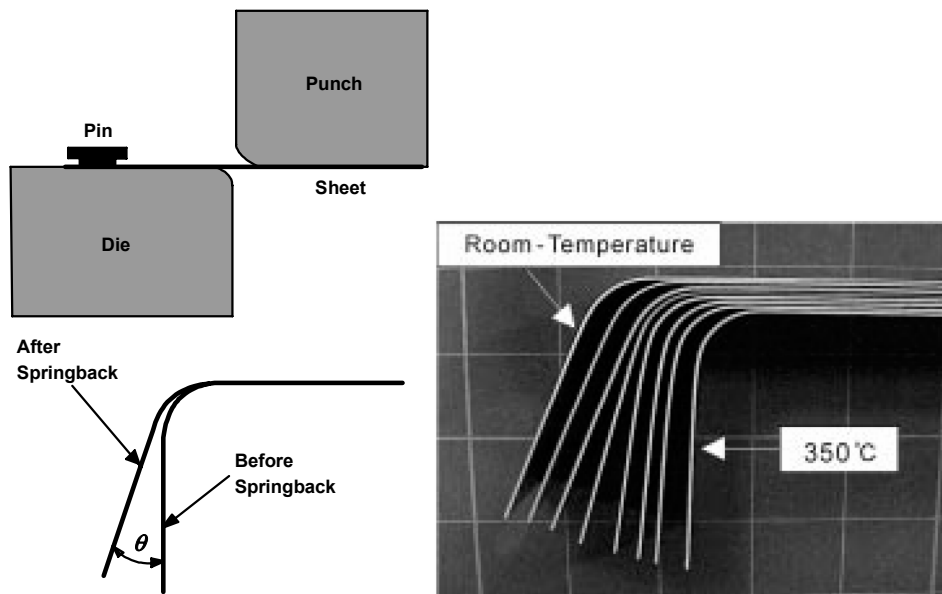
Bolt et al [10] used a paste from Petrofer called Isoform WP5 in a recent work (2001).

Ghosh [48] used Boron Nitride. Boron Nitride is available as an aerosol spray and is, according to the supplier, an excellent lubrication agent for high temperature (up to 1800°C) [49].

Sagström et al [50] used a solid graphite lubricant (Molykote D 321 R from Dow Corning). According to the supplier the lubricant can be used up to 450°C and the coefficient of friction is 0.075 [51].

## 2.8 Springback

The effect on springback in warm sheet metal forming has been investigated for the aluminum alloys 1050 and 5052 by Keum & Han [38]. They performed bending tests in a furnace up to 350°C and they conclude that temperature has a large influence on the amount of springback. This can be seen in Figure 2.33.



*Figure 2.33: Experimental setup to the left and springback of 5052 (in 0° direction) to the right [38].*

Moon et al. [47] have also studied the aluminum alloy 1050 and the temperature effect on springback. The test equipment can be seen in Figure 2.34. They made

tests with two different punch temperatures (-10 and 25°C) and with three different die temperatures (25, 100 and 200°C). They also used different ram speeds and they conclude that the forming rate has a large influence. At a ram speed of 1 mm/s the springback at room temperature is 8.5° and if the die temperature is raised to 200°C (and punch temperature kept at 25°C) the springback is 4.7°. If the speed is raised to 10 mm/s though the difference is slight.

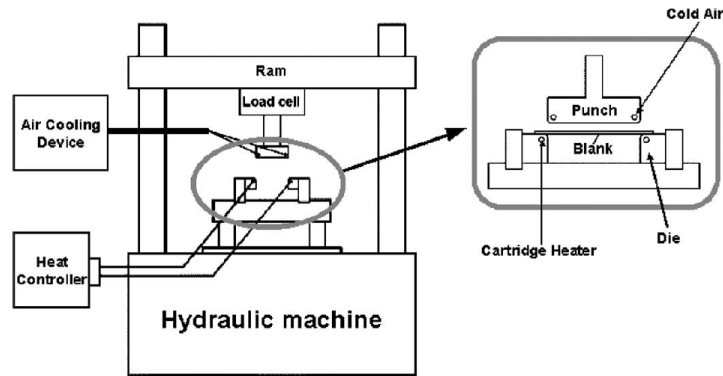


Figure 2.34: Bending test equipment [47].

V-bend tests has been performed by Chen & Huang [46] on the magnesium alloy AZ31. They used temperatures up to 300°C and different punch radius. The effect of temperature and punch radii can be seen in Figure 2.35.

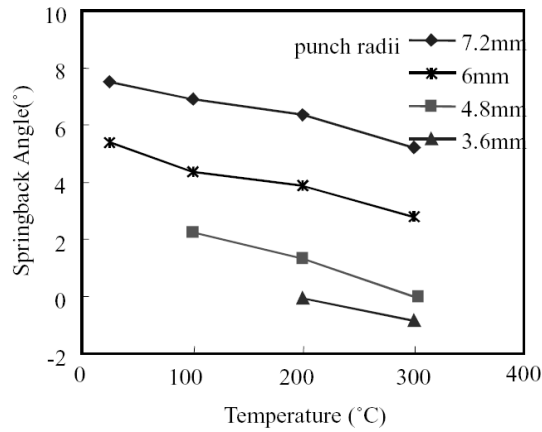


Figure 2.35: Springback of AZ31 [46].



## 2.9 Forming limit curves

Naka et al. [8] have tried to measure the biaxial stretch-formability of 1 mm thick 5083-O at various temperatures (from 25 to 300°C) and punch speeds (from 0.2 to 200 mm min<sup>-1</sup>) by determining forming limit diagrams (FLD). An electric heater installed in the punch heated the specimens, and the strain paths were monitored (by the help of scribed circles) with a CCD camera. Figure 2.36 shows their results.

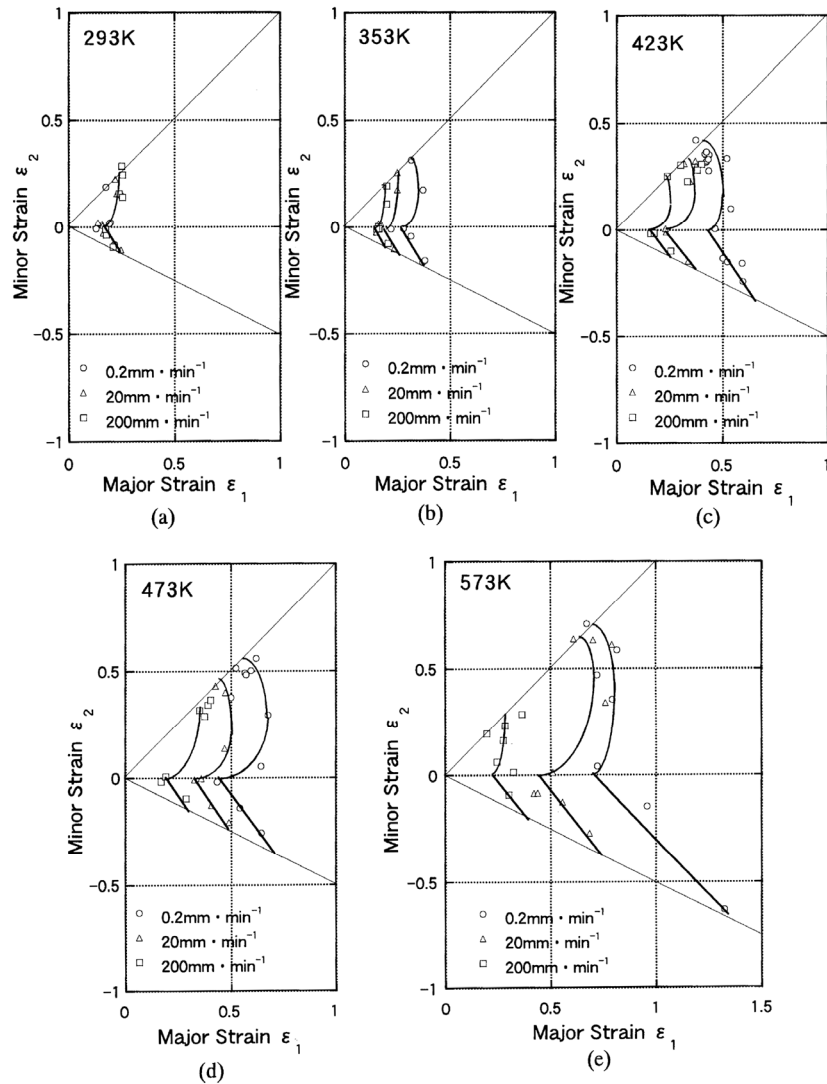
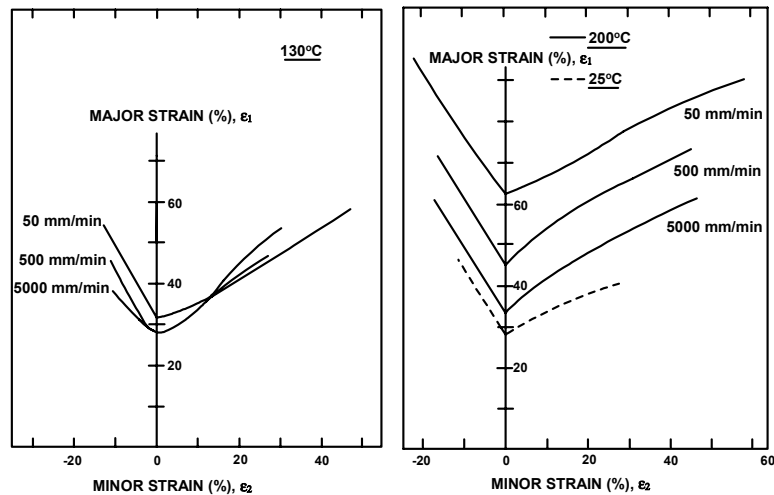


Figure 2.36: Forming limit diagrams for 1 mm thick 5083-O, obtained at various temperatures at several punch speeds [8].

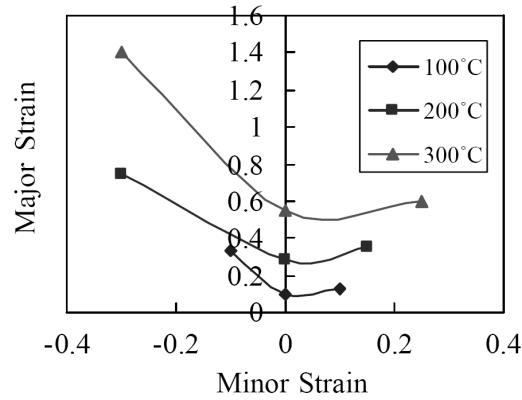
It is concluded that at high temperature the limit strain increases drastically with decreasing punch speed, while at room temperature this dependency is not that pronounced. They further conclude that the high formability at 300°C at low punch speed is specifically due to the high strain rate hardening ( $m$ -value), but at lower temperatures the formability is also strongly affected by the strain hardening ( $n$ -value).

Also Ayres & Wenner [6] studied biaxial stretch-formability by determining forming limit diagrams. They used 1.3 mm thick 5182-O at temperatures 25, 130 and 200°C at various punch speeds (50, 500 and 5000 mm min<sup>-1</sup>). Their results are shown in Figure 2.37. As in the experiments of Naka et al. the large increase in forming limit with decreasing punch speed is observed at high temperatures while only a modest increase at 130°C and almost no punch speed effect at room temperature is observed.



**Figure 2.37:** Forming limit diagrams for 1.3 mm thick 5182-O, obtained at various temperatures and punch speeds [6].

The magnesium alloy AZ31 has been studied by Chen & Huang [46] and among others they determined forming limit curves for the alloy at 100, 200 and 300°C. A thickness of 1.2 mm was used and specimens with different widths were stretched to failure over a 78 mm semi-spherical punch. Figure 2.38 shows the forming limit curves obtained.



**Figure 2.38:** Forming limit curves for 1.2 mm thick AZ31, obtained at various temperatures [46].

## 2.10 Numerical modeling

As shown in chapter 2.2 the strain rate sensitivity is very important at warm forming temperatures. In [37] (and [52]) Boogard uses the extended material model

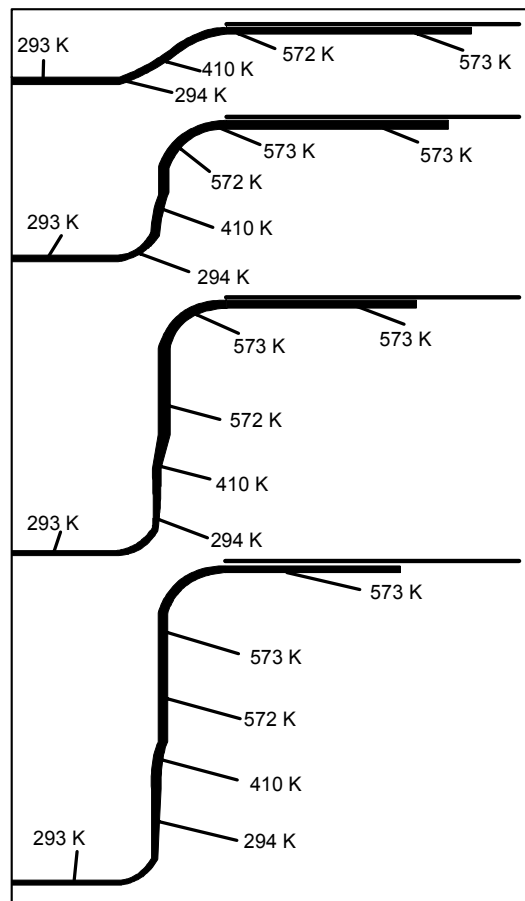
$$\sigma = C(\varepsilon + \varepsilon_0)^n \left( \frac{\dot{\varepsilon}}{\dot{\varepsilon}_0} \right)^m \quad (1.4)$$

and the Bergström model [53-54] to model the aluminum alloy 5754-O. The Bergström model is a physically based model which previously has been used for hot forming simulation of steel [55]. Boogard applies the material models to the finite element simulation of cylindrical cup deep drawing and he compares the use of the two material models with experiments. He concludes that the coefficient of friction is a very uncertain (and important) factor that needs to be further investigated before any conclusions can be drawn.

Takuda et al. [9] have done finite element simulations of warm deep drawing of aluminum. They used a combination of the rigid-plastic and the heat conduction finite element methods. The constitutive equation  $\sigma = k \cdot \varepsilon^n$  have been used so the strain rate hardening has not been taken into account. By comparing their results with experimental they conclude that the simulation successfully predicts the forming limit and the necking site.

Xing & Makinouchi [19] deduced a general constitutive equation with temperature dependent material properties and applied it successfully to warm deep drawing.

El-Morsy & Manabe [23] have done FE-simulations of the warm deep drawing process of a cup in magnesium alloy AZ31. They used the constitutive equation  $\sigma = k\varepsilon^n \dot{\varepsilon}^m$  so the strain rate hardening has been taken into account. Two models were used. The first one with the die and the blank holder heated to 300°C while the punch is kept at room temperature. The initial temperature of the blank is room temperature. In the second model everything (blank, blank holder, die and punch) is heated to 300°C initially so no heat transfer takes place. The simulations show that in the first model (with heat transfer) the blank can be drawn to a much higher cup height (50 mm) than in the second model without heat transfer (cup height 18 mm). This is due to the presence of localized thinning in the second model. Figure 2.39 shows the temperature distribution of the deformed blank in the first model.



**Figure 2.39:** Temperature distribution [23].

Also Chen et al [56] and Palaniswamy et al. [57] have made deep drawing simulations of the magnesium alloy AZ31, probably without taking the strain rate sensitivity into consideration though.

Lee et al. [27] made a finite element analysis in their study on the warm deep drawability of steel sheets (see chapter 2.4). DYNA-3D explicit code was used and the blank model was divided into a cooling zone and a heating zone. The temperature of the heating zone was gradually increased and temperature dependent material properties were used. The heat transfer effect between the punch and the blank is not considered in the simulation though and the authors conclude that this would have been desired to obtain more accurate results.

Takuda et al. [29] analyzed warm deep drawing of 304 stainless steel by using a combination of the rigid-plastic and heat conduction finite element methods. The flow stress in their simulations is a function of temperature and strain also taking the martensitic transformation in 304 stainless steel into consideration. They conclude that the forming limit and the fracture initiation sites are successfully predicted in their work. Figure 2.24 shows the good agreement between experiments and calculations.

## 2.11 Discussion and Conclusions

A tensile test at elevated temperature reveals that for aluminum alloys the yield strength decreases and the post-uniform elongation increases with increasing temperature. Furthermore the strain hardening decreases but the strain rate hardening increases. Magnesium alloys show a similar behavior, but seem to be even more sensitive to temperature and strain rate. Mild steel does not exhibit the same temperature dependence. At temperatures up to 300°C the tensile strength only decreases slightly and the elongation decreases. Stainless steel on the other hand shows a remarkable decrease in tensile strength at only 150°C.

An important result is that a suitable combination of temperature and strain rate can eliminate the so called stretcher-strain marks that appear on the surface of Al-Mg alloys (5xxx-alloys). In general Al-Mg alloys have good formability, but can not be used for visible panels in the automobile industry because of the marks. These alloys are therefore often used for non-visible panels like the inner structure of doors, hoods etc. For visible outer panels Al-Mg-Si alloys (6xxx-alloys) are used. Consequently warm sheet metal forming can be used to produce visible outer panels in Al-Mg alloys.

Forming trials show that the deep drawability of aluminum alloys can be improved remarkably, especially if a temperature distribution over the blank is accomplished

(with for instance a heated die and a cooled punch). For magnesium alloys the improvement is even larger and a uniform heated blank can be used. Deep drawing trials of mild steel indicate that also warm sheet metal forming of steel can be beneficial. Also trials with stainless steel and titanium show promising results.

Although only a limited number of trials on the springback of aluminum alloys at elevated temperature have been performed it seems that temperature has a large influence on the amount of springback. Springback is a major problem in the sheet metal forming of aluminum and a reduction of springback in conjunction with the elimination of stretcher-strain marks are highly appealing.



## 3 Concepts of Warm Sheet Metal Forming

### 3.1 Introduction

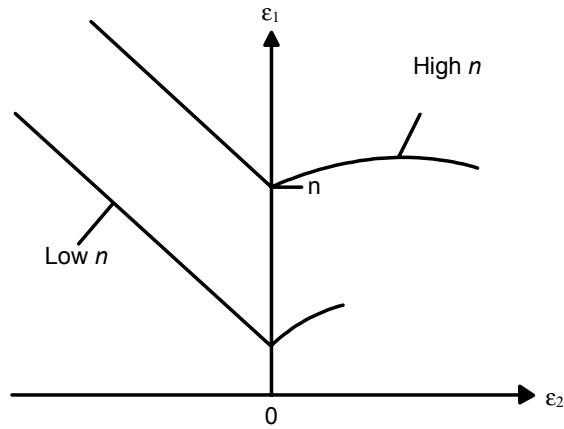
When reviewing warm sheet metal forming in the literature, two basic concepts can be recognized. Either the entire blank is heated to one temperature or the temperature over the blank varies. It is important to distinguish these two from each other and from now the two concepts will be termed as “warm sheet metal forming with a *globally* heated blank” or “warm sheet metal forming with a *locally* heated blank”.

A *globally* heated blank is heated to one temperature evenly over the entire blank. This heating can be accomplished in an oven externally, internally through conduction from a heated tool or by a combination where the blank is heated in an oven externally and then placed in a heated tool.

A *locally* heated blank is not heated to one temperature throughout the blank, but the temperature varies over the blank. One way to accomplish this temperature distribution over the blank is to heat the die and the blank holder and cool the punch. When reviewing the literature this is how it is usually done. Another way to accomplish the desired temperature distribution will be proposed and discussed in the subsequent chapters.

The two different concepts obtain the possible advantage of increased formability compared to ordinary sheet metal forming in different ways. In ordinary (cold) sheet metal forming, strain hardening is usually the most important factor affecting formability. In Figure 3.1 forming limit curves for a high and a low strain hardening material can be seen [58].





**Figure 3.1:** Effect of strain hardening on the forming limit curve [58].

The warm sheet metal forming with a globally heated blank is essentially based upon that the increased strain rate hardening is more favorable for the formability than the decreased strain hardening. With a locally heated blank, the locally decreased resistance to deformation in the sheet can be used to increase the limiting drawing ratio and consequently accomplish a deeper draw. Figure 3.2 illustrates the two different concepts (and ordinary sheet metal forming) which will be discussed in the following of this chapter.

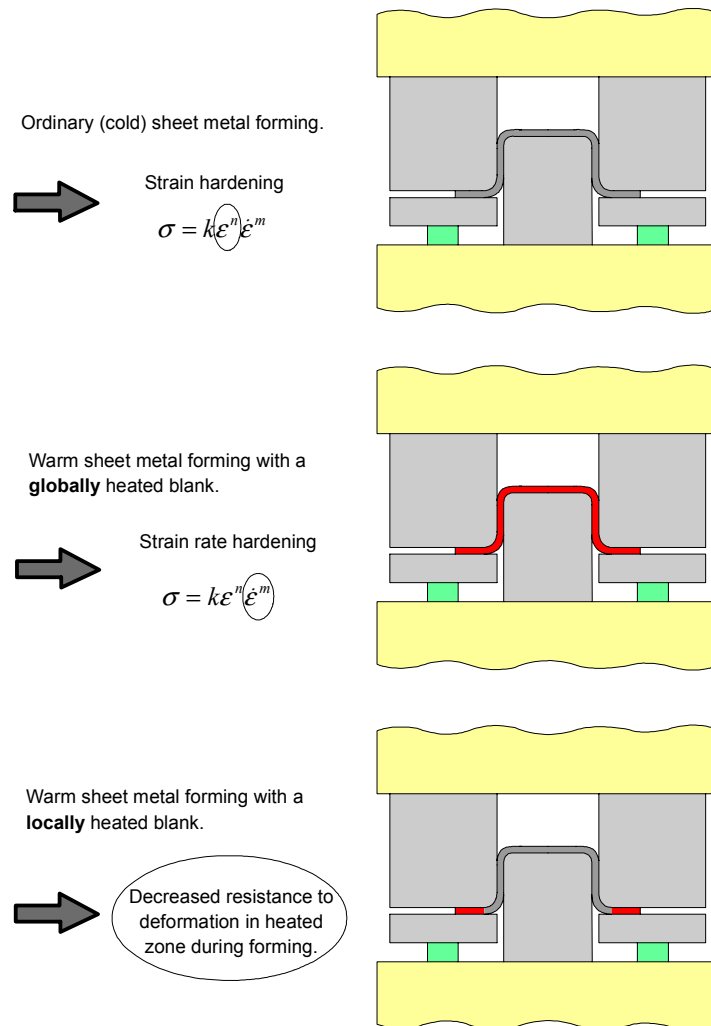
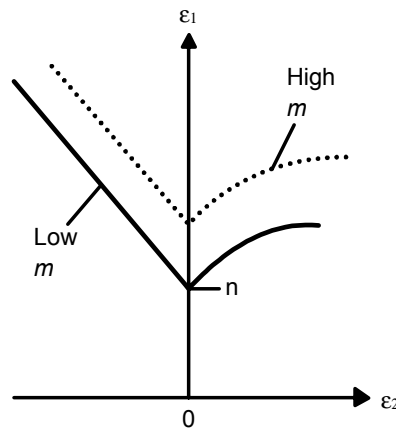


Figure 3.2: Utilized properties in different concepts.

### 3.2 Globally heated blank

As the review in chapter 2 showed the yield strength decreases, the post-uniform elongation increases and the decreasing strain hardening is compensated with an increasing strain rate hardening when the temperature is elevated. As mentioned in the introduction to this chapter strain hardening is an important factor in sheet metal forming because of its large influence on the formability. Strain hardening

can be thought of as a materials ability to distribute the deformation to neighboring parts of the sheet, delaying the formation of local necking. Rate sensitivity will influence the rate of growth of a neck. In biaxial stretching rate sensitivity will delay growth of a neck. For a material with low rate sensitivity the forming limit curve will intercept the major strain axis at a strain close to the strain hardening exponent  $n$ . A material with high strain sensitivity will shift the curve upwards as shown in Figure 3.3 [58].



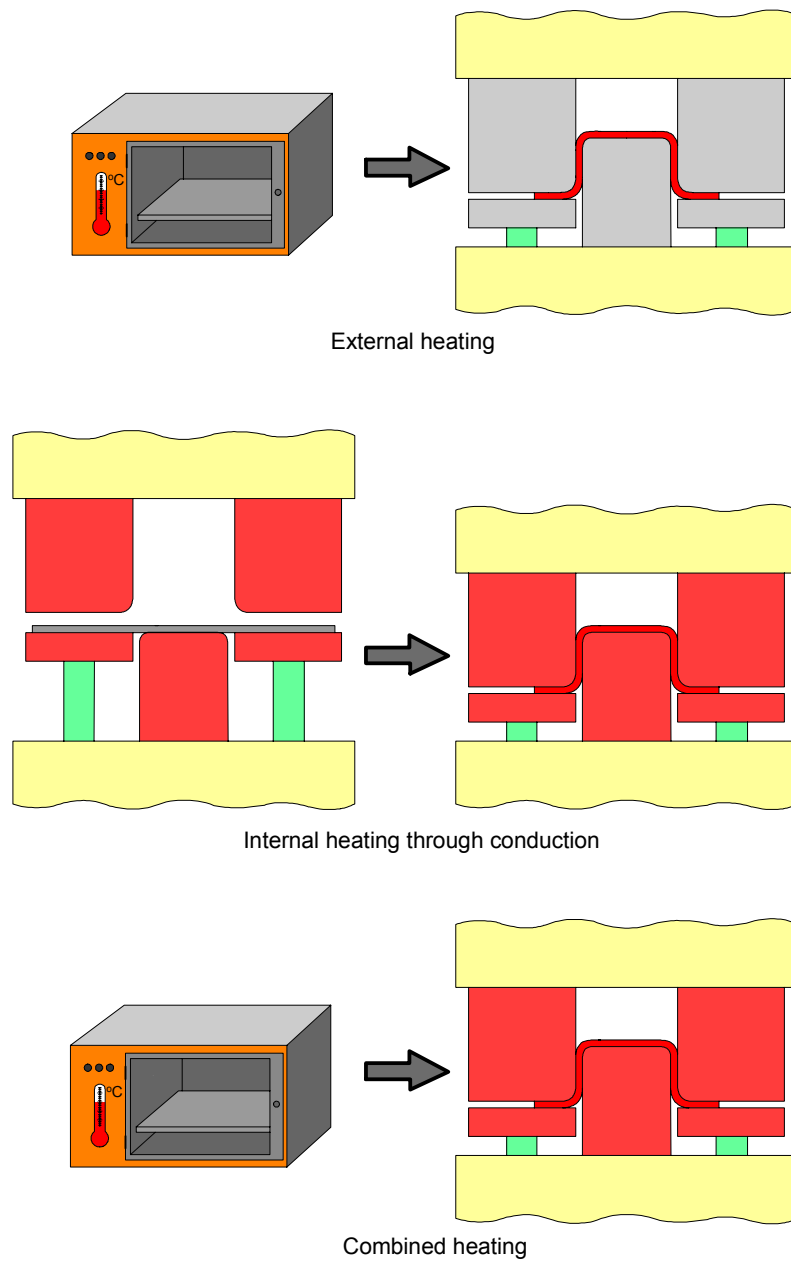
**Figure 3.3:** Effect of rate sensitivity on the forming limit curve [58].

Heating the blank globally to one temperature can be done more easily than heating it locally (and creating a temperature distribution over the blank). The blank should probably be kept at the same temperature throughout the forming and this must be considered when choosing a suitable heating method.

In running production matters such as equipment for heating and handling, production rate etc also becomes relevant. These issues will not be discussed in this chapter, but will be touched briefly for one specific process in chapter 5 where the manufacturing performance of the specific process is evaluated.

When reviewing the literature two different basic concepts can be recognized for heating the blank globally. The blank can be heated externally in an oven or internally in a heated tool. Of course also a combination of these two concepts can be used.

Figure 3.4 shows the three different methods and these will be discussed below.



**Figure 3.4:** Globally heated blank.

### **3.2.1 External heating**

In its simplest form the blank is heated in an oven, until the desired temperature is reached, and then placed into an ordinary (cold) tool. Basically any type of oven can be used, but besides basic properties like possibility to obtain the desired temperature, large enough etc a fast heating process is desirable. Problems with maintaining the desired temperature in the blank can be expected since the blank has to be moved from the oven to the tool and since the tool itself will cool the blank. The blank also has to be handled when it is warm.

Although the drawbacks this could be a fast and simple way to perform a starting trial. As mentioned one can expect several problems, but the most severe is probably to maintain the temperature throughout the forming process. The performance and also control of the process will most probably be insufficient for running production.

### **3.2.2 Internal heating through conduction**

To avoid the problems with loss of heat when moving the blank from an oven to the tool and also the cooling effect from the tool, the blank can be heated internally through conduction from a heated tool. As described in chapter 2 a common way is to use electrical resistance heaters inserted at different locations into the tool. A large mass (the tool) should then be heated and insulation is necessary to avoid loss of heat to the press frame etc. Figure 2.23 shows a tool where the heated die and blank holder is insulated.

The efficiency of the process will be a problem since a large amount of material (the tool) has to be heated in order to heat the relatively small amount of material made up by the blank. Obtaining an even temperature over the blank might be a problem since the contact between the different parts of the tool and the blank will vary. The blank will probably warp because of this and needs to be held between the blank holder and the die by a small pressure.

### **3.2.3 Combined heating**

The two concepts above can of course be used in combination. The heating in the oven can then be seen as a pre-heating to make the process faster and to avoid problems with an even temperature distribution that might occur as described above. Also the heating time in the press can be minimized. No problems with cooling from the tool will occur using a heated tool.

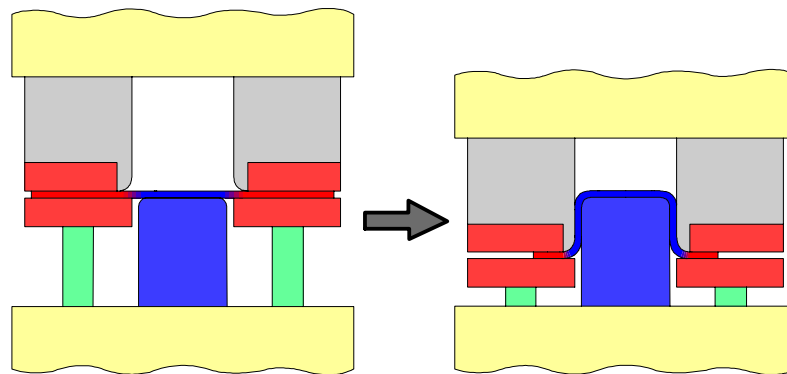
### 3.3 Locally heated blank

If the drawing load in a sheet metal forming process is too high, the sheet will crack in the region of the punch radius or the die radius. It is therefore desirable to minimize the drawing load. Increasing the drawing ratio increases the drawing load because of a larger contact area. Since cracking occurs when the drawing load exceeds the load that can be transmitted by the sheet, there is a maximum allowable drawing load and thus a maximum allowable drawing ratio, i.e. the limiting drawing ratio. The maximum drawing load can, according to Siebel and Beisswanger [32], in a simplified form be calculated as

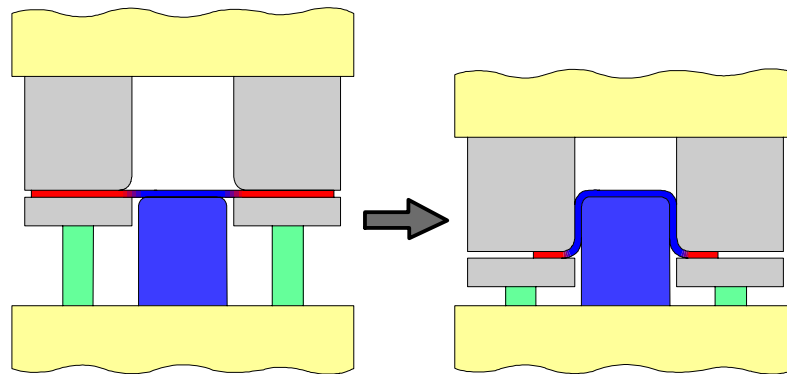
$$F_{d,max} = \pi d_m s_0 \left( 1.1 \frac{\sigma_{f,m,l}}{\eta_{def}} \left( \ln \frac{d_0}{d_1} - 0.25 \right) \right) \quad (3.1)$$

where  $\sigma_{f,m,l}$  is the mean flow stress in the flange. Thus, if one can manage to reduce the flow stress in the flange, the drawing load can be decreased and consequently the limiting drawing ratio increased. As shown in chapter 2 the yield strength decreases with increasing temperature. Localized heating of the blank in the flange region will therefore achieve the desired reduction of flow stress in that region.

The blank can be heated internally in a tool that has a heated die and blank holder and a cooled punch. If the blank could be heated internally without heating the tool this would also be a possible solution. Figure 3.5 shows the two different concepts and these will be discussed below.



Internal heating and cooling through conduction



Internal heating in cold tool

*Figure 3.5: Locally heated blank.*

### 3.3.1 Internal heating and cooling through conduction

As described in chapter 2 several studies conclude that a heated blank holder and die and a cooled punch is favorable for the formability. When the cold blank is placed in a tool heated in this fashion, only the flange region will be heated. During forming the cooled punch will cool the interior of the blank, maintaining the desired temperature distribution, and as described above the formability will be increased.

If one lets a tempered tool heat/cool the blank the heating and cooling of the different parts of the tool can be achieved in different ways. The most common way is to place electrical heating rods in the die and in the blank holder and

circulate cool water through the punch. As described before the efficiency of the process will be a problem since a large amount of material (the die and the blank holder) has to be heated in order to heat the relatively small amount of material made up by the blank. Also a long time is required to reach the desired temperature of the tool.

To avoid warping of the blank it will need to be held between the blank holder and the die by a small pressure during the heating phase before the actual forming starts.

### **3.3.2 Internal heating in cold tool**

If the desired temperature distribution could be accomplished in the blank without heating the tool a much more efficient and faster process could be accomplished. Such a process is proposed and discussed in the next chapter.

## **3.4 Discussion and Conclusions**

Different concept of warm sheet metal forming is presented in this chapter. The concepts are divided into two basic groups based on the temperature distribution over the blank. If the blank is heated to one temperature (globally heated blank), strain sensitivity becomes a key parameter in the forming process. The review in chapter 2 showed that an increased strain rate hardening could be more favorable for the formability than the decreased strain hardening, but often that is not the case. It is showed that more often it is more favorable to heat the blank just in the flange area (usually by using a heated die and blank holder combined with a cooled punch). This kind of process (termed sheet metal forming with a locally heated blank) is also discussed in this chapter.

If the blank should be heated globally, the best way is probably to use the combined method described in chapter 3.2.3. As for sheet metal forming with a locally heated blank the method described in chapter 3.3.1 (were the die and blank holder is heated and the punch is cooled) have in the review showed to be successful. The drawback is that parts of the tool itself have to be heated in order to heat the blank. In the following chapter a process is described were the blank can be heated locally inside the tool without actually heating the tool.





## **4 Localized In-Tool Induction Heating**

### **4.1 Introduction**

As described in previous chapters the temperature distribution over the blank can be accomplished by heating certain parts of the pressing tool and cooling others and warm/cool the blank through conduction of heat. This procedure requires temperature control of a large amount of material only to heat the relatively small amount of material made up by the blank. If one could heat the blank (selectively) when placed inside the tool, *without* heating the tool a much more efficient process can be expected. Furthermore the geometry of the tool will not be influenced and also a more selective and controllable heating could be accomplished.

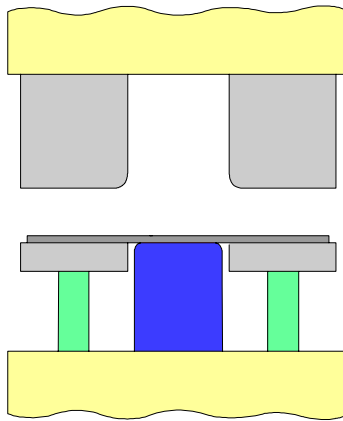
The process described can be accomplished by integrating induction heating into the forming tool and this is described in this chapter.

### **4.2 Process description**

The process is based on the use of an induction heating system that is located inside (and in the nearness) of the pressing tool. By using induction heating integrated into the tool the blank can be heated just prior to the forming *and* continually during the forming process. The continual heating during forming is important to assure that the desired temperature distribution is maintained throughout the stroke.

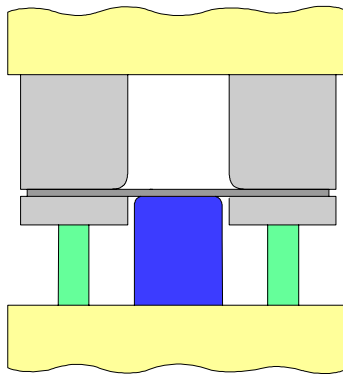
The steps given below gives an example of a typical forming operation, illustrated by Figure 4.1 to Figure 4.5.

1. The blank is first coated with a suitable lubricant regarding the forming temperature. The lubricant can be sprayed or otherwise applied to the blank. With the die in its upper position, the blank is placed on the blank holder.



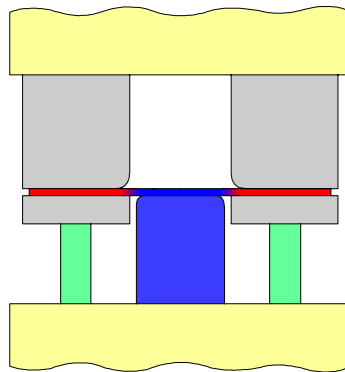
**Figure 4.1:** The blank placed inside the tool.

2. After the blank has been placed inside the tool, the upper die moves down and clamps the blank between the die and the blank holder.



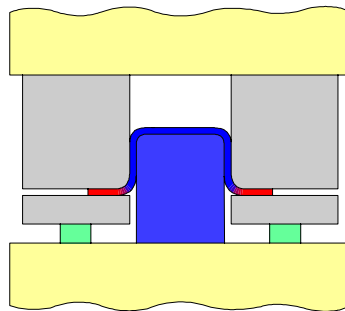
**Figure 4.2:** Clamping of the blank.

3. The blank is then heated in the flange area until the desired temperature and temperature distribution over the sheet has been reached. The process control is preferably done by temperature feedback. By the use of several coils the temperature distribution over the flange area can be more specifically controlled. Using induction heating, which is a fast heating process, the time the upper die stands still can be minimized.



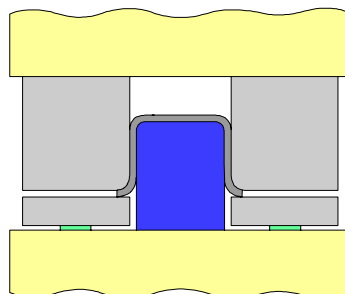
**Figure 4.3:** Preheating.

4. When the desired temperature distribution has been reached the press cycle continues. The die moves further down until the blank meets the punch. During the forming of the blank over the punch, the blank is further heated in the flange area by one or several coils. The cooled punch helps maintaining the temperature distribution.



**Figure 4.4:** Forming.

5. The finished part can after forming be extracted from the tool.



**Figure 4.5:** Finished part.

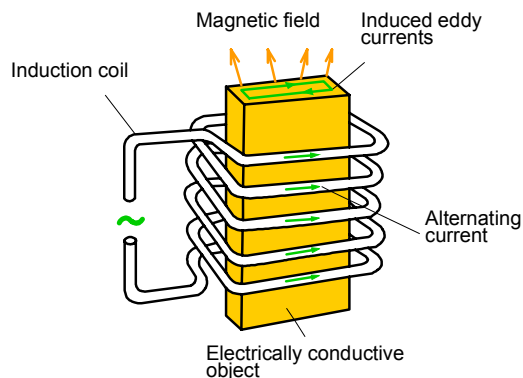
## 4.3 Induction heating system

### 4.3.1 Introduction

Induction heating can be found in a wide range of industries and applications, from large melting equipment in the casting industry to small cap sealing equipment in the food industry. An induction heating system consists of induction coil, flux concentrator, phase advancing/resonance capacitor, step-down transformer and switched power electronics. These will be discussed below, but first a theoretical background will be given.

### 4.3.2 Theoretical background

When an alternating voltage is applied to an induction coil an alternating current is obtained and this alternating current will produce a magnetic field. If an electrically conductive object is placed inside or in the nearness of the coil, eddy currents will be induced in the object (Faraday's law). These currents will produce heat as a result of the Joule effect. The principle is illustrated in Figure 4.6 and this is the basic electromagnetic phenomenon behind what is called induction heating.



*Figure 4.6: Currents and magnetic fields.*

The rate at which the workpiece is heated depends on the frequency and the intensity of the induced current as well as material properties like the specific heat, the magnetic permeability and the electrical resistivity of the material.

Electrical resistivity measures the ability of a material to resist the conduction of an electric current (and is thus the reciprocal of electrical conductivity). The electrical resistivity varies with temperature. For pure metals the resistivity can often be approximated with the linear expression

$$\rho(T) = \rho_0(1 + \alpha(T - T_0)) \quad (4.1)$$

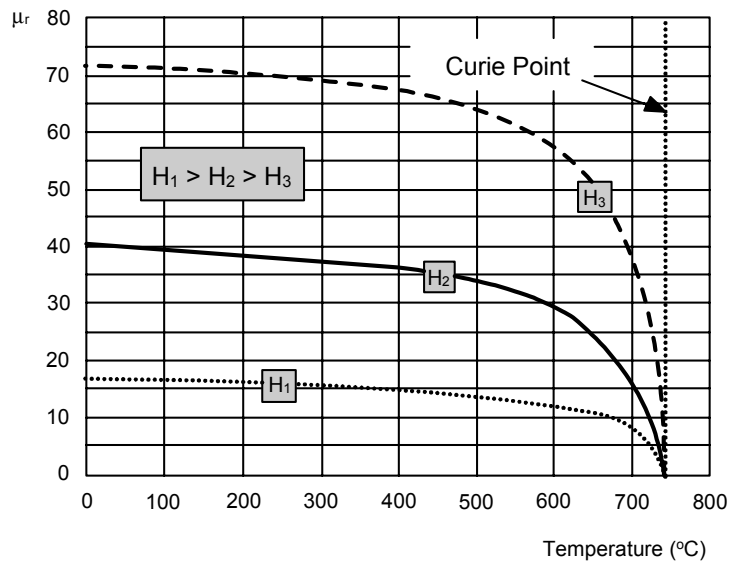
where  $\rho(T)$  is the resistivity at temperature  $T$ ,  $\rho_0$  is the resistivity at the temperature  $T_0$  and  $\alpha$  is the temperature coefficient. Table 4.1 shows the electrical resistivity and the temperature coefficient for some metals (at room temperature).

**Table 4.1:** Electrical resistivity and temperature coefficient for some metals [59].

<b>Metal</b>	<b>Electrical resistivity (<math>\mu\Omega m</math>)</b>	<b>Temperature coefficient (<math>K^{-1}</math>)</b>
Silver	0,016	0,0038
Copper	0,017	0,0039
Gold	0,022	0,0040
Aluminum	0,027	0,0043
Iron	0,105	0,0066
Zinc	0,058	0,0037

As can be seen in Table 4.1 the electrical resistivity of iron is high (compared to e.g. aluminum). Aluminum and other metals with low electrical resistivity will therefore take longer time to heat compared to metals with high electrical resistivity like steel. As mentioned before the resistivity increases with increasing temperature, therefore at higher temperatures the workpiece will be more receptive to induction heating than at lower temperatures.

Relative magnetic permeability,  $\mu_r$ , measures the ability (relative air) of a material to conduct magnetic flux. Based on their magnetization ability materials can be divided into para-, dia- and ferromagnetic materials. For paramagnetic materials the relative magnetic permeability is slightly greater than 1 and diamagnetic materials has  $\mu_r$  slightly less than 1. These kinds of materials are usually called nonmagnetic materials (e.g. aluminum, copper and titan). Ferromagnetic materials have a high value of relative magnetic permeability. The relative magnetic permeability depends among others on the temperature and on the magnetic field intensity and only a limited number of materials are ferromagnetic at room temperature (e.g. iron, cobalt and nickel). The temperature at which a ferromagnetic material becomes nonmagnetic is called the Curie-point. Figure 4.7 shows the relative magnetic permeability,  $\mu_r$  as a function of temperature and magnetic field intensity of medium carbon steel.



**Figure 4.7:** Relative magnetic permeability as a function of temperature and magnetic field intensity of medium carbon steel [59].

Magnetic materials are easier to heat with induction heating than non-magnetic materials. This is because magnetic materials also produce heat by what is called the hysteresis effect. As a magnetic workpiece is being heated the alternating magnetic flux field causes the magnetic dipoles of the material to oscillate. This oscillation is called hysteresis. Heat is produced due to the friction when the dipoles oscillate.

An alternating current flowing through a conductor causes a non-uniform current distribution within the conductor cross section. The current density has its maximum value at the surface of the conductor and decreases towards its center. This is called the skin effect and the same phenomenon can be found in the work piece located inside the induction coil where the current density of the eddy current has its maximum value at the surface. This is a very important effect in induction heating. The skin effect depends on the frequency, the electrical resistivity and the relative magnetic permeability. The layer where most of the power is concentrated due to the skin effect is called the penetration depth. The penetration depth is also affected by a number of other electromagnetic phenomena e.g. the proximity effect.

### 4.3.3 Induction coil

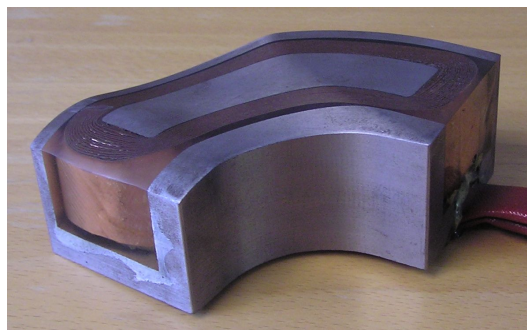
The induction coil is traditionally made of a copper tube that is adapted to the specific process. The coil will be highly heated both due to the alternating current passing in the coil, but also from induced voltage as a result of the alternating

magnetic field that tries to penetrate the coil. Therefore, the cavity of the coil is often flushed with a cooling liquid. A more recent approach is to make the coil from litz cables making it possible to run without fluid cooling and instead using air cooling.

#### 4.3.4 Flux concentrator

The flux concentrator keeps the flux inside a high permeability flux conductor when not inside the work piece. This increases the controllability of the heated zone and decreases the magnetically stored energy, resulting in a greatly improved efficiency. The desired properties of the flux concentrator material are high resistivity in, at least one direction, high permeability and high saturation magnetization. Flux concentrator materials can be made of laminated structures for lower frequencies, of ferrites or with soft-magnetic composites e.g. isolated iron particles in a polymer matrix.

For the warm forming process described in this chapter the use of a flux concentrator made of a soft-magnetic composite is much suitable. One material that can be used is Permedyn. Permedyn is an isotropic flux conductor which permits three-dimensional magnetic fields. The material can be machined into complex geometries and can therefore easily be integrated into the forming tools. Figure 4.8 shows an example where Permedyn has been used to create an induction unit with a curved surface.



*Figure 4.8: Induction unit with curved surface.*

#### 4.3.5 Phase advancing/resonance capacitor

When utilizing induction heating the power factor of the load, especially with work pieces made of low permeability materials, is low, in the order of 0.1. This means that some form of resonance circuit must be used. One common way is to connect a resonance tuned capacitor in series with the heating coil. This will correct the power factor and decrease the impedance but will also increase the voltage by as



much as 100 times. The high voltages on the secondary side of the isolation transformer results in electrical isolation problems.

### **4.3.6 Step-down transformer**

In order to keep the voltage over the heating coil low and to galvanically isolate the coil from the grid, a full, step-down transformer is used. When the heating coil is going to be used for different kinds of material it is common to have more than one primary winding or/and more than one secondary winding. By utilizing a combination of the windings some different winding ratios can be realized so that good impedance matching the induction coil and capacitor can be achieved.

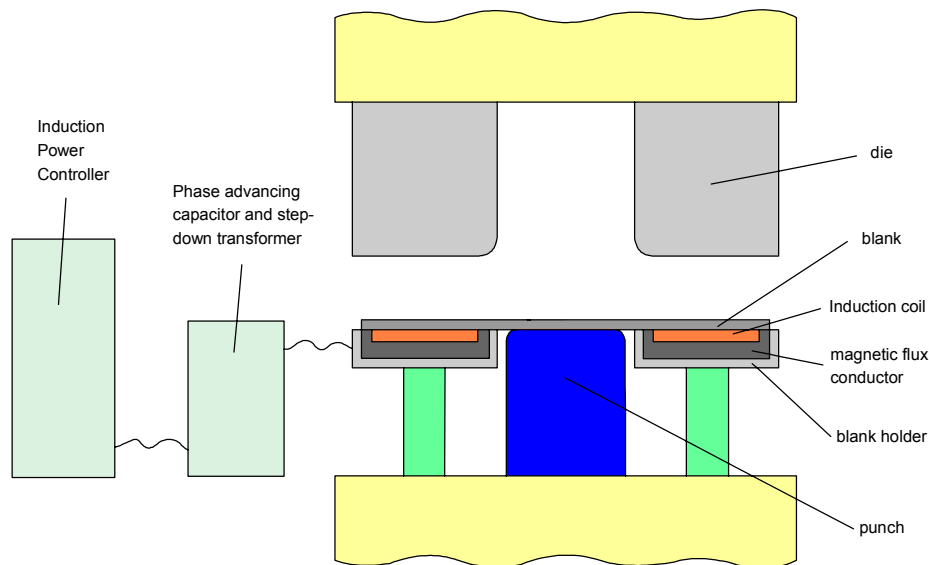
### **4.3.7 Switched mode power electronics**

The power electronics powering the induction heater is built on switching technology unless the 50/60 Hz from the grid is used directly. The switching frequency is usually in the range 1 kHz-1 MHz. The output heating power is controlled either by pulse width modulation, PWM, or with frequency control. The frequency control works by changing the frequency with respect to the resonance frequency so that maximum active output power is at resonance and minimum active output power is far away from the resonance frequency. The output active power is equal to the power factor multiplied with the maximum total power.

## **4.4 Tool integration**

As described in the previous chapter the induction heating system consists of induction coil, magnetic flux conductor, phase advancing/resonance capacitor, step-down transformer, and switched power electronics.

The induction unit (the induction coil and the magnetic flux conductor) is integrated into the forming tool. The phase advancing/resonance capacitor and the step-down transformer is located outside the tool, but in its nearness. Since the blank is to be heated in the flange region, the induction unit can be placed either in the die or in the blank holder. Figure 4.9 shows a tool setup with the induction unit integrated into the blank holder.



**Figure 4.9:** Warm sheet metal forming with Localized In-Tool Induction Heating.

When integrating the induction unit into the blank holder, no other considerations than to embrace the induction coil and the magnetic flux conductor have to be made. The blank holder can therefore be made of ordinary tool steel with cavities containing the induction unit. Since the blank slides over the surface of the blank holder, there has to be a thin layer of material between the induction unit and the blank. This is to obtain a satisfactory sliding condition between the blank and the blank holder. This coating has to withstand the applicable temperature and also be resistant to wear. The material in the coating should preferably be chosen so that the coating is not heated by the induction units. The material can therefore be chosen based on what material is to be formed (i.e. the blank material). A ceramic, e.g. aluminum oxide can be used independent of this due to its poor conductivity.

The die has no other specifications than a die used in ordinary (cold) sheet metal forming. The induction unit can be placed in the die instead of the blank holder, but because of the more complex geometry on the die the induction unit is preferably placed in the blank holder.

The punch has the same specifications as it would have in ordinary (cold) sheet metal forming, besides that it may be cooled. If the punch should be cooled or not depends on heating zones, blank material, temperatures, production rate etc.

## **4.5 Discussion and Conclusions**

This chapter gives a suggestion on how to accomplish the desired temperature distribution over the blank without using heated tools. By integrating induction heating into the tool only a short pre-heating time needs to be used. The pre-heating time depends of course on the sheet material, the size of the blank, available power, temperature etc, but is in the area of seconds.

The process described in this chapter has a patent pending [60].

# 5 Process Potential: A Case Study

## 5.1 Introduction

To evaluate the potential of the process a case study of the manufacturing performance has been conducted. Manufacturing performance refers (in an industrial engineering sense) to the ability to manufacture a component *with the right quality, in time and at the right cost*. *With the right quality* refers to the dimensions, surface quality and properties of the component. *In time* refers to delivery of the product at the planned point of time and *at the right cost* refers to the estimated cost [33].

An increase in production rate makes it more difficult to fulfil the three parameters mentioned above. This is because the consequence of disruptions gets more extensive at a higher production rate. To avoid disruptions when increasing the production rate, technical development and an increase in competence is often needed [33].

Many tools have been developed to study the causes of manufacturing disruptions and accomplish improvements in quality. The Seven QC-tools, the Five Why's, Six Sigma and the Manufacturing Performance Matrix (MPM) are some of them. The Manufacturing Performance Matrix has been developed at the Division of Production and Materials Engineering at Lund Institute of Technology. This method will be used in the case study performed.

## 5.2 The Manufacturing Performance Matrix (MPM)

The Manufacturing Performance Matrix can be applied in several different ways. Fundamental for the method is to be able to study disruptions and its causes in a simple and structural manner. The main fields of application are:

- Follow-up running production, aiming at finding organizations or technologies that can be improved.
- Support for the introduction of a new production system.
- Documentation of experiences and competence in a structured way.

The method has mainly been used as a foundation for improvements of running production as the first item above describes. As the second item describes the method can be used to review a new process or technology and compare it with the existing running production.

### **5.2.1 Process Parameters**

The production performance can be described in a number of process parameters. These process parameters can be divided into three main groups:

- Quality parameters (Q) with respect to dimensions, surfaces and properties.
- Standstill parameters (S) with respect to standstill related to the manufacturing process (e.g. failures and adjustments).
- Productivity parameters (P) that describe loss in production rate (e.g. shortage on personnel).

The process parameters that can be identified in a certain process are grouped according to above and termed Q1, Q2...Qn or S1, S2...Sn etc. Sometimes environmental- and recycling parameters are identified and added in a similar manner as a fourth group.

### **5.2.2 Factor groups**

A disruption is associated or influenced by a number of factors. Many different factors can have impact on the production performance in a certain stage of the processing. To be able to do a systematical analysis, the factors can be grouped into eight main groups. These groups are called factor groups and are:

- A. Tool
- B. Work piece
- C. Process
- D. Personnel and organization
- E. Wear and maintenance
- F. Special production related factors
- G. Surrounding equipment
- H. Other

The groups A-D and G give input to the system. Group A contains factors related to the geometry, surfaces and material properties of the tool. "Tool" gets different implications depending on what manufacturing method is being used. Group B contains similar factors as A, but also factors related to the machinability, formability, castability or what is applicable. Process (C) contains equipment

factors, process data, additives and operations planning and group D handling and instructions of use.

Group E and F is a consequence from running production. Special production related factors (F) could be machine- or tool setup, idle time before repairing etc or others that are specific for the manufacturing process used.

It is important that the group H is used at doubts, in order to keep up the quality of the specified groups.

### 5.2.3 Matrix

The manufacturing performance matrix is made up from the factor groups as rows and the performance parameters as columns, as shown in Figure 5.1. When a disturbance is observed it is classified with respect to the factor groups and performance parameters and then the value in that specific cell is increased. Depending on what data is put into the cells three different analyses can be made:

- **Frequency analysis.** This is the simplest analysis, which only shows how many disturbances that has occurred. One disturbance increases the value in a specific cell with 1. No concern is made to the loss of time or cost the disturbance causes.
- **Time analysis.** Here the disturbance increases the value in the cell with the length of the disturbance, measured in minutes.
- **Cost analysis.** Here the cost for the disturbance is put into the cell. This is the most comprehensive analysis.

A simpler analysis, like the frequency analysis, demands a more detailed discussion afterwards where time and cost is considered as well.

Factor groups	Performance parameters		
	Quality parameters (Q1, Q2, ..., Qn)	Standstill parameters (S1, S2, ..., Sn)	Productivity parameters (P1, P2, ..., Pn)
A. Tool (A1, A2, ..., An)			
B. Work piece (B1, B2, ..., Bn)			
C. Process (C1, C2, ..., Cn)			
D. Personnel and organization (D1, D2, ..., Dn)			
E. Wear and maintenance (E1, E2, ..., En)			
F. Special process factors (F1, F2, ..., Fn)			
G. Surrounding equipment (G1, G2, ..., Gn)			
H. Other (H1, H2, ..., Hn)			

Figure 5.1: Manufacturing Performance Matrix

By summing up the columns the effect of a specific performance parameter can be studied. Analogous summing up of rows gives the effect of a specific factor. This is illustrated in Figure 5.2.

	Q1	Q2	Q3	...	Pn	$\Sigma$
A1						
A2						
A3						$\Sigma A3$
$\vdots$						
Gn						
$\Sigma$		$\Sigma Q2$				

Figure 5.2: Summing up in the matrix.

## 5.3 Case Study

A case study has been performed aiming at comparing the warm sheet metal forming process described in chapter 3 with traditional sheet metal forming. The case study was conducted at Volvo Cars Body Components (VCBC) in Olofström. The detail studied is the outer trunk lid for the model S60. This trunk lid is made of aluminum in a single-action hydraulic press. The use of aluminum saves weight and gives corrosive benefits, but the material is more complicated to form. Also some additional aspects have to be considered when using aluminum (compared to steel). Among others is aluminum more sensitive for scratches and marks, the material is delivered in cut blanks, which are coated with a dry-lube, the material handling system uses suction cups since aluminum is non-magnetic and aluminum is more sensitive to temperature variations.

The study is based on the spring production of the detail (week 0301 to week 0327). During this period 38.778 details were produced under a total time of 176.6 hours. Essentially the documentation of faulty details and the time documentation for the production line together with interviews with the line manager is the foundation for the study. The performance parameters identified are:

Q1: Deformed part

Q2: Cracks

Q3: Dimensional error

Q4: Surface defects

S1: Planned stops (mainly setup)

S2: Unplanned stops

P1: Production rate

Factor groups identified are:

A1: Slivers

A2: Dirt

A3: Scrap remaining

A4: Broken sensor

A5: Scratches

B1: Wrong material properties

B2: Wrong blank size

B3: Surface defects or surface roughness

B4: Wrong temperature on the material

C1: Press velocity



C2: Amount of lubricant  
C3: Temperature on lubricant  
C4: Wrong position of the blank

D1: Handling  
D2: Instructions of use

E1: Tool maintenance  
E2: Press maintenance

F1: Adjustment of stop lug with shims  
F2: Tool change

G1: Handling equipment (mainly suction cups)  
G2: Induction heating (surrounding equipment)

These performance parameters and factor groups are a result of both the actual production of the trunk lid and the warm forming process described.

Figure 5.3 below gives the results from the traditional production of the trunk lid as described above. The study is made as a time analysis. This means that each disturbance increases the value in a cell with the length of the disturbance, measured in minutes. Since the quantity of faulty details is measured, this number has been translated into a production loss measured in minutes.

Figure 5.4 shows the MPM for warm sheet metal forming with Localized In-Tool Induction Heating. The matrix is adjusted, based on qualified guesses due to the assumed process performance of the method, as follows:

- Since the relevant material properties of the sheet becomes more important and also more numerous when introducing heat into the process one can expect an increase in the number of details with cracks. The increase is estimated to 25%, which increases the value in that cell from 3 minutes to 4 minutes.
- The setup time at a tool change will probably increase due to the more complex equipment surrounding the induction heating system. The increase is estimated to 25%, which increases the value in “planned stops” from 552 minutes to 690 minutes.
- The unplanned stops will probably become more numerous due to the surrounding induction heating equipment since this makes the process more complex (compared to traditional sheet metal forming). The increase during the time period studied (176.6 hours in total) is estimated to 10 hours (600 minutes).

- The introduction of additional parameters and more complex equipment will also make the instructions of use more difficult. It is therefore likely that the unplanned stops will increase due to this factor. The value in this cell has been estimated to 2 hours (120 minutes) during the time period studied.
- The two large time posts in the MPM is the unplanned stops due to the amount of lubricant and due to the adjustment of the stop lugs in the tool. This is because the forming window for the process is very small. These two parameters have therefore to be adjusted often to be able to keep the process within the forming window. A larger forming window is consequently of great importance. The use of the warm forming method described will give the possibility to produce more complex shapes, but will also increase the forming window for a given detail that can be manufactured with traditional sheet metal forming, but with a small forming window. Therefore the values in these two cells are decreased with 25% giving 1649 minutes and 2061 minutes respectively.

Factor groups		Performance parameters						$\Sigma$ Factors	
		Q Quality parameters				S Standstill parameters			P Prod. param.
		Q1 Deformed part	Q2 Cracks	Q3 Dimensional error	Q4 Surface defects	S1 Planned stops	S2 Unplanned stops		P1 Production rate
<b>A Tool</b>	A1 Slivers				22				22
	A2 Dirt				2				2
	A3 Scrap remaining	23							23
	A4 Broken sensor	3							3
	A5 Scratches								
<b>B Work piece</b>	B1 Wrong material properties		3						3
	B2 Wrong blank size								
	B3: Surface defects or surface roughness								
	B4: Wrong temperature on the material								
<b>C Process</b>	C1 Press velocity								
	C2 Amount of lubricant						2198		2198
	C3 Temperature on lubricant								
	C4 Wrong position of the blank			1			550		551
<b>D Personnel and organization</b>	D1 Handling	10							10
	D2 Instructions of use								
<b>E Wear and maintenance</b>	E1 Tool maintenance								
	E2 Press maintenance								
<b>F Special process factors</b>	F1 Adjustment of stop lugs with shims						2748		2748
	F2 Tool change					552			552
<b>G Surrounding equipment</b>	G1 Handling equipment (mainly suction cups)	9							9
	G2 Induction heating (surrounding eq.)								
<b><math>\Sigma</math> Performance parameters</b>		<b>45</b>	<b>3</b>	<b>1</b>	<b>24</b>	<b>552</b>	<b>5496</b>		<b>6121</b>

*Figure 5.3: MPM with disturbance measured in minutes for outer trunk lid with traditional sheet metal forming.*

Factor groups		Performance parameters						Σ Factors	
		Q Quality parameters				S Standstill parameters			P Prod. param.
		Q1 Deformed part	Q2 Cracks	Q3 Dimensional error	Q4 Surface defects	S1 Planned stops	S2 Unplanned stops		P1 Production rate
<b>A Tool</b>	A1 Slivers				22				22
	A2 Dirt				2				2
	A3 Scrap remaining	23							23
	A4 Broken sensor	3							3
	A5 Scratches								
<b>B Work piece</b>	B1 Wrong material properties		4						4
	B2 Wrong blank size								
	B3: Surface defects or surface roughness								
	B4: Wrong temperature on the material								
<b>C Process</b>	C1 Press velocity								
	C2 Amount of lubricant						1649		1649
	C3 Temperature on lubricant								
	C4 Wrong position of the blank			1			550		551
<b>D Personnel and organization</b>	D1 Handling	10							10
	D2 Instructions of use						120		120
<b>E Wear and maintenance</b>	E1 Tool maintenance								
	E2 Press maintenance								
<b>F Special process factors</b>	F1 Adjustment of stop lugs with shims						2061		2061
	F2 Tool change					690			690
<b>G Surrounding equipment</b>	G1 Handling equipment (mainly suction cups)	9							9
	G2 Induction heating (surrounding eq.)						600		600
<b>Σ Performance parameters</b>		<b>45</b>	<b>4</b>	<b>1</b>	<b>24</b>	<b>690</b>	<b>4980</b>		<b>5744</b>

Figure 5.4: MPM with disturbance measured in minutes for warm sheet metal forming.

## 5.4 Discussion and Conclusions

The MPM is adjusted compared to traditional sheet metal forming as shown in Figure 5.4. The adjustment is based on the discussion given in the previous subsection.

Summing up the down time in the manufacturing performance matrixes gives 6121 minutes (102 hours) and 5744 minutes (96 hours) respectively. This means that, the benefits of in particular a larger forming window is more favorable for the manufacturing performance, although a more complex process has been introduced. Figure 5.5 gives the comparison between the traditional sheet metal forming and the warm sheet metal forming in available hours and down time hours.

	Traditional sheet metal forming	Warm sheet metal forming
Available (h)	74.6 (42%)	80.6 (46%)
Down time (h)	102 (58%)	96 (54%)
Total (h)	176.6	176.6

*Figure 5.5: Availability.*

The down time is 58%, which can seem very high. This high down time (mainly due to unplanned stops) is typical when manufacturing a detail in aluminum. Compared to steel, the unplanned stops are 8 times higher when working with aluminum [34].

The study shows that the warm sheet metal forming process has a better manufacturing performance than traditional sheet metal forming. The difference is slight and is based upon more or less qualified guesses about the performance of the, for the time being, theoretical warm forming process. The discussion above about the adjustment of the manufacturing performance matrix is probably essentially correct, but the actual values are more uncertain.

## 6 Discussion and Conclusions

This chapter sums up the subsections that are given at the end of each chapter where some discussions and conclusions have been made. A more profound material can thus be found in these subsections.

The review in chapter 2 shows some of the potential of warm sheet metal forming. The effect of elevated temperature on the basic tensile data are presented in this chapter as well as formability data in form of forming limit curves, limiting drawing ratios, maximum dome heights etc. The potential of warm sheet metal forming depends on sheet material and specific forming process, but the general impression is that remarkable improvements can be achieved. This is especially true for deep drawing of aluminum alloys and magnesium alloys. Very important is also the elimination of stretcher-strain marks on aluminum-magnesium alloys (5xxx-alloys) because of their use in the automobile industry in large quantities. Also the reduction of springback is highly interesting.

From the review it can be concluded that warm sheet metal forming has a great potential, but the tools and the processes must be further developed to meet production demands.

In the present work a classification has been made based on the temperature distribution over the blank. The terms *globally heated blank* and *locally heated blank* are introduced and are established and discussed in chapter 3. Based on this and on the review in chapter 2 the following of the thesis treats a new forming process called *Localized In-Tool Induction Heating*. The most attractive quality of the process is that the blank can be given the desired temperature distribution in a short period of time and that the blank can be heated continually during the forming process. The short heating time makes the process suitable for running production. The case study of the manufacturing performance in chapter 5 shows that warm sheet metal forming with Localized In-Tool Induction Heating should be competitive compared to traditional sheet metal forming.



## **7 Further Research**

In this thesis a new forming process with a concept called Localized In-Tool Induction Heating has been introduced. The process should be further refined and trials must be done in laboratory scale with a simple tool where Localized In-Tool Induction Heating is implemented.

The induction heating technique is quite well developed, but needs to be adapted to the application. The integration of the induction unit into the tool must for example be studied as this is of great importance for the result.

In order to optimize the process computer simulations (e.g. finite element simulations) can be used. The induction heating as well as the forming process can be analyzed with these kinds of simulations and this will probably be of great help in the design of the equipment. In order to perform satisfying simulations the sheet materials of interest must be studied, e.g. the mechanical properties at elevated temperature must be determined.

The trials in laboratory scale must be followed by trials with more complicated tools, comparable to those used in running production. In chapter 5 the manufacturing performance was studied and further studies of this kind of must be made to adapt and optimize the process to running production.





## References

- [1] Novotny, Celeghini, Geiger, Measurement of material properties of aluminum sheet alloys at elevated temperatures, Proceedings of the Eighth SheMet'00, Birmingham, 2000
- [2] Magnesium Taschenbuch, Aluminium-Verlag, Dusseldorf, 2000
- [3] Doege, Dröder, Sheet metal forming of magnesium wrought alloys – formability and process technology, Journal of Materials Processing Technology, 2001
- [4] Shehata, Painter, Pearce, Warm forming of aluminium/magnesium alloy sheet, International conference on warm working, Sunderland, 1978
- [5] Naka, Yoshida, Deep drawability of type 5083 aluminium-magnesium alloy sheet under various conditions of temperature and forming speed, Journal of Materials Processing Technology, 1999
- [6] Ayres, Wenner, Strain and strain rate hardening effects on punch stretching of 5182-O aluminum at elevated temperatures, Sheet Met. Ind. 55 (11) 1208, 1978
- [7] Kalpakjian, Serope, Manufacturing Processes for Engineering Materials, 3<sup>rd</sup> ed 1997
- [8] Naka, Torikai, Hino, Yoshida, The effects of temperature and forming speed on the forming limit diagram for type 5083 aluminum-magnesium alloy sheet, Journal of Materials Processing Technology, 2001
- [9] Takuda, Mori, Masuda, Abe, Matsuo, Finite element simulation of warm deep drawing of aluminum alloy sheet when accounting for heat conduction, Journal of Materials Processing Technology, 2002
- [10] Bolt, Lamboo, Rozier, Feasibility of warm drawing of aluminium products, Journal of Materials Processing Technology, 2001
- [11] Dröder, Janssen, Forming of Magnesium alloys – A solution for light weight constructions, SAE paper 1999-01-3172, 1999
- [12] Finch, Wilson, Dorn, Deep-drawing aluminum alloys at elevated temperatures, Part I – Deep drawing cylindrical cups, ASM Trans. 36 254-289, 1946
- [13] Finch, Wilson, Dorn, Deep-drawing aluminum alloys at elevated temperatures, Part II – Deep drawing boxes, ASM Trans. 36 290-310, 1946
- [14] Moon, Kang, Park, Gong, Tool temperature control to increase the deep drawability of aluminum 1050 sheet, International Journal of Machine Tools & Manufacture, 2001

- [15] Taylor, Lanning, Warm forming of aluminium – production systems, Proceedings of the 25<sup>th</sup> National SAMPE Symposium, pp 471-480, 1980
- [16] Ayres, Lanning, Taylor, Heimbuch, Brazier, Warm forming the GM V-6 oil pan in aluminum, SAE Tech. paper no. 780180, Society of automotive engineers , pp. 702-706, 1978
- [17] Fuchs, Williams, Strain measurements at elevated temperature and high strain rates, 5<sup>th</sup> Annual Environments and High Temperatures Measurements Conference Proceedings, Society for Experimental mechanics, 42-48, 1988
- [18] Taylor, Heimbuch, Babcock, Warm forming of aluminum, Proc. 2<sup>nd</sup> International Conference on Mechanical behavior of Materials, Federation of Materials Societies (Boston , MA), 2004-2008, 1976
- [19] Xing, Makinouchi, FE modeling of thermo-elasto-plastic finite deformation and its application in sheet warm forming, Engineering Computations, Vol. 19, No. 4, pp. 392-410, 2002
- [20] Morris, George, Warm forming high-strength Al automotive parts, International Automotive Engineering Congress and Exposition, Society of automotive Engineers, paper 770206, pp. 1-9, 1977
- [21] Li, Ghosh, Tensile deformation behavior of aluminum alloys at warm forming temperatures, Materials science and engineering A352 (2003) 279-286
- [22] Romhanji, Dudukovska, Glisic, The effect of temperature on strain-rate sensitivity in high strength Al-Mg alloy sheet, Journal of Materials Processing Technology, 2002
- [23] El-Morsy, Manabe, FE Analysis of Warm Deep-Drawing Process of Magnesium Alloy Sheet, Proceedings of the 53<sup>rd</sup> Japanese Joint Conference for the Technology of Plasticity, December 22-24, 2002, Hamamatsu
- [24] Schuöcker, Schröder, Laser assisted deep drawing - a challenge for ultra high beam power, Laser Assisted Net shape Engineering 2, Proceedings of the LANE'97, eds.: M. Geiger, F. Vollertsen, Mesienbach Bamberg 1997
- [25] Kim, Ryu, Choi, Na, Kim, Investigation of warm deep drawability of square cups of ANSI 304 stainless sheet, 5th International Conference on Technology of Plasticity, October 7-10, Columbus, 1996, pp. 739-742
- [26] Ayres, Alloying Aluminum with magnesium for ductility at warm temperatures (20-250°C), Metallurgical Transactions A, Volume 10A, (1979), pp. 849-854
- [27] Lee, Heo, Chang, Choi, Kim, Seo, A Study on the warm deep drawability of sheets in Cr-coated die, KSME International Journal Vol. 15, No 7, pp. 839-846, 2001
- [28] Leighton, Lee, The effect of tooling temperature on the formability of sheet steel, Journal of Materials Processing Technology 45 (1994) 577-582
- [29] Takuda, Mori, Masashika, Yamazaki, Watanabe, Finite element analysis of the formability of an austenitic stainless steel sheet in warm deep drawing, Journal of Materials Processing Technology 143-144 (2003) 242-248
- [30] Smallman, Bishop, Metals and Materials, Butterworth - Heinemann, 1995

- 
- [31] Polmear, Light Alloys Metallurgy of the Light Metals, Butterworth – Heinemann, 3<sup>rd</sup> ed. 1995
- [32] Siebel, Beisswänger, Tiefziehen : Forschungsarbeiten auf dem Gebiete des Tiefziehens im Auftrage der Forschungsgesellschaft Blechverarbeitung, München, Carl Hanser, 1955
- [33] Ståhl J-E m.fl., Industriella tillverkningsystem, Mekanisk teknologi och verktygsmaskiner, LTH, Lunds universitet, KFS 2005 (in Swedish)
- [34] Andersson A, Assarsson J, Ingemansson A, Front Fender – Aluminum versus Steel, PROPER 1999
- [35] Boogaard, Bolt, Werkhoven, Aluminum sheet forming at elevated temperatures, In: Simulation of Materials Processing: Theory, Methods and Applications K.- I. Mori (ed.), pp. 819-824, Swets & Zeitlinger, Lisse, 2001
- [36] Bolt, Werkhoven, Boogaard, Effect of elevated temperatures on the drawability of aluminium sheet components, Proceedings of the 4th Esaform Conference on Material Forming, A. M. Habraken (ed.), Liege, pp. 769-772, 2001
- [37] Boogaard, Thermally enhanced forming of aluminium sheet - Modelling and experiments, Ph. D. thesis, University of Twente, 2002
- [38] Keum, Han, Springback of FCC sheet in warm forming, Journal of ceramic Processing Research, Vol. 3, No. 3, pp. 159-165, 2002
- [39] Backofen, Deformation processing, Reading, MA: Addison-Wesley Pub. Co., 1972
- [40] Jäger, Lukác, Gärtnerová, Bohlen, Kainer, Tensile properties of hot rolled AZ31 Mg alloy sheets at elevated temperatures, Journal of Alloys and Compounds 378 184-187 2004
- [41] Chang, Chou, Microstructural effects on formability of type 304 stainless steel sheet in cylindrical deep drawing, Journal of materials engineering and performance 3(4) august 1994 551
- [42] Chang, Chou, Microstructures and formability of type 304 stainless steel in deep drawing, Scripta Metallurgica at materialia vol 31 no 10 1291-1296 1994
- [43] Dröder, Untersuchungen zum Umformen von Feinblechen aus Magnesiumknetlegierungen, Ph.D. Thesis, University of Hannover, 1999 (in German)
- [44] Stalman, Sebastian, Friedrich, Schumann, Dröder, Properties and Processing of Magnesium Wrought Products for Automotive Applications, Advanced Engineering Materials 2001, 3, No. 12
- [45] Liu, Chou, Study on the microstructure of commercially pure titanium in two-temperatrue deep drawing, Journal of materials processing technology 95 65-70 1999
- [46] Chen, Huang, Formability of stamping magnesium-alloy AZ31 sheets, Journal of materials processing technology 142 643-647 2003
- [47] Moon, Kang, Cho, Kim, Effect of tool temperature on the reduction of the springback of aluminum sheets, Journal of Materials Processing Technology 132 (2003) 365-368

- [48] Ghosh, Sheet metal stamping die design for warm forming, United States Patent 6,550,302.
- [49] Data sheet for Boron Nitride Spray BNSP-S from SHS Ceramics S. A.
- [50] Sagström, Troell, Ingemarsson, Moshfegh, Wadman, Plåtformning vid förhöjd temperature, IVF-skrift 02809, 2003 (in Swedish)
- [51] Data sheet for Molykote D 321 R from Dow Corning
- [52] Boogaard, Bolt, Werkhoven, A material model for aluminum sheet forming at elevated temperatures, Proceedings of the 4th international Esaform Conference on Material Forming, A.M. Habraken (ed.), Liege, pp. 309-312, 2001
- [53] Bergström, Dislocation model for the stress-strain behaviour of polycrystalline  $\alpha$ -Fe with special emphasis on the variation of the densities of mobile and immobile dislocations, Materials science and engineering, vol 5, pp. 193-200, 1969
- [54] Bergström, The plastic deformation of metals – a dislocation model and its applicability, Reviews on Powder Metallurgy and Physical Ceramics, vol. 2, pp. 105-115, 1983
- [55] Rietman, Numerical analysis of inhomogeneous deformation in plane strain compression, Ph. D. Thesis, University of Twente, 1999
- [56] Chen, Huang, Chang, Deep drawing of square cups with magnesium alloy AZ31 sheet, International Journal of Machine Tools & Manufacture 43 2003 1553-1559
- [57] Palaniswamy, Ngaile, Altan, Finite element simulation of magnesium alloy sheet forming at elevated temperatures, Journal of materials processing technology 146 52-60 2004
- [58] Marciniak, Duncan, Hu, Mechanics of Sheet Metal Forming, Butterworth-Heinemann, 2<sup>nd</sup> ed., 2002
- [59] Rudnev, Loveless, Cook, Black, Handbook of Induction Heating, Marcel Dekker, 2003
- [60] Larsson L, Cedell T, Ståhl J-E, Warm forming device, reg. nr 0402190-3, 2005-02-09, Patent pending