



LUND UNIVERSITY

Nonlinear Feedforward and Reference Systems for Adaptive Flight Control

Pettersson, Anders; Åström, Karl Johan; Robertsson, Anders; Johansson, Rolf

Published in:
2013 AIAA Guidance, Navigation, and Control Conference

DOI:
[10.2514/6.2013-5001](https://doi.org/10.2514/6.2013-5001)

2013

[Link to publication](#)

Citation for published version (APA):
Pettersson, A., Åström, K. J., Robertsson, A., & Johansson, R. (2013). Nonlinear Feedforward and Reference Systems for Adaptive Flight Control. In *2013 AIAA Guidance, Navigation, and Control Conference*
<https://doi.org/10.2514/6.2013-5001>

Total number of authors:
4

General rights

Unless other specific re-use rights are stated the following general rights apply:
Copyright and moral rights for the publications made accessible in the public portal are retained by the authors and/or other copyright owners and it is a condition of accessing publications that users recognise and abide by the legal requirements associated with these rights.

- Users may download and print one copy of any publication from the public portal for the purpose of private study or research.
- You may not further distribute the material or use it for any profit-making activity or commercial gain
- You may freely distribute the URL identifying the publication in the public portal

Read more about Creative commons licenses: <https://creativecommons.org/licenses/>

Take down policy

If you believe that this document breaches copyright please contact us providing details, and we will remove access to the work immediately and investigate your claim.

LUND UNIVERSITY

PO Box 117
221 00 Lund
+46 46-222 00 00

Nonlinear Feedforward and Reference Systems for Adaptive Flight Control.

Anders Pettersson¹

SAAB AB & Lund University, SE-58188 Linköping, Sweden

Karl J. Åström², Anders Robertsson³, Rolf Johansson⁴

Lund University, SE-22100 Lund, Sweden

Use of feedforward can alleviate feedback and adaptive actions. Feedforward signals can be generated from reference models and the same models can also be used as reference models in adaptive control. A method for designing the reference models is presented in the paper. By exploiting the structure of the equations describing air vehicles it is possible to find reference models that scale to the present flight condition and vehicle configuration. Such reference systems are derived for flying vehicles in a generic manner, suitable for both winged aircraft and missiles. The same type of reference systems are also used to create trajectories for feedforward signals that compensate known plant non-linearities.

Nomenclature

\bar{v}	=	vehicle velocity vector, with vector elements u , v and w
$\bar{\omega}$	=	vehicle angular velocity vector, with vector elements p , q and r
V	=	airspeed, the norm of the velocity vector
α	=	angle of attack
β	=	angle of sideslip
m, I_i	=	mass and mass inertia tensor
\bar{F}, \bar{M}	=	force and moment acting on vehicle
ρ	=	density of air at the vehicle altitude
S, b, c	=	reference area and reference lengths, related to aerodynamic properties of the vehicle
$\delta_a, \delta_e, \delta_r$	=	control surface deflections, aileron, elevator, rudder
L	=	state-feedback gain
$H_m(s)$	=	desired transfer function from plant input to output
K_g	=	steady state inverse gain of desired transfer function from plant input to output

I. Introduction

This work is part of a feasibility study of adaptive control for winged aircraft and missiles^{10,11}. Reference models are required when using adaptive control methods such as MRAC^{1,2} or L1 adaptive control³. Even though adaptive control techniques can cope with large parameter variations, there are cases that pose severe difficulties. The roll rotation of a flying vehicle, addressed in^{6,7} is one problem but there are also other elements that need special attention. The problem of finding relevant reference systems for flight will be addressed by using fundamentals of the vehicle properties and known nonlinearities such as cross couplings due to roll motion will be compensated by feedforward signals.

One contribution in this work is a procedure to generate linear reference systems for generic flying vehicles. The work effort will be reduced for designing desired dynamics and a corresponding state feedback gain throughout the vehicle Mach and altitude envelope (the standard gain-scheduling industrial procedure¹⁵). Three parameters (roll, pitch and yaw) will be tuned for one flight condition. The reference systems then scale to the present flight condition

¹ Systems Engineer & Doctoral Student, SAAB AB & Lund University, andersp@control.lth.se, AIAA Member

² Professor Emeritus of Automatic Control, Department of Automatic Control, Lund University, kja@control.lth.se

³ Professor, Department of Automatic Control, Lund University, andersro@control.lth.se

⁴ Professor, Department of Automatic Control, Lund University, rolf.johansson@control.lth.se

using fundamentals from the nominal dynamics of the vehicle using speed, altitude, mass, mass inertia and aerodynamics properties. Linear state feedback gains that nominally make the system follow the reference system are then derived.

The work also contributes with a way of reducing workload for an adaptive controller, using a design of nonlinear feedforward signals that make the vehicle behave like the linear reference system dynamics, by using the vehicle angular velocity vector as a virtual control signal. This feedforward design exploits the particular structure of flight dynamics. A general method to generate feedforward signals for nonlinear systems based on the notion of flatness is given in⁴.

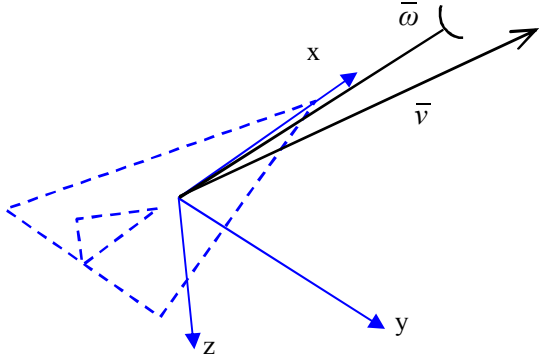

Figure 1 Generic flying vehicle with body coordinate system, velocity vector and angular velocity vector in three dimensions, body velocity vector \bar{v} and body angular velocity vector $\bar{\omega}$.

This paper starts with a parameterized representation of open-loop dynamics for flying vehicles. Then, closed-loops are given desired dynamics by linear state feedback. A feedforward compensator is derived that makes the vehicle dynamics act like the linear reference system and simulations using the design are presented.

II. Nominal dynamic motion of a flying vehicle

States expressing the rigid-body-motion of a flying vehicle will be established, together with the time derivatives of these states. This model will then be used both for deriving linear systems for design of control algorithms as well as for simulating the full nonlinear system, a well-known procedure within aerospace engineering⁸.

A. State equation details

Definitions of vectors and co-ordinates⁸ for creating motion equations are visualized in Fig. 1. Motion around the body co-ordinate system x , y , and z -axis is defined as roll, pitch and yaw dynamics, respectively.

Expressing velocity derivatives according to Newton's second law:

$$\dot{\bar{v}} = m^{-1}\bar{F} - \bar{\omega} \times \bar{v}$$

and angular velocity derivatives according to the Euler equation:

$$\dot{\bar{\omega}} = I_i^{-1}(\bar{M} + \bar{\omega} \times I_i \bar{\omega})$$

will give expressions in Eq. (1) for the time derivative of the system state x .

$$\dot{x} = \begin{pmatrix} \dot{V} \\ \dot{\alpha} \\ \dot{\beta} \\ \dot{p} \\ \dot{q} \\ \dot{r} \end{pmatrix} = \begin{pmatrix} \left(\begin{array}{c} \frac{1}{m}(F_x \cos \alpha \cos \beta + F_y \sin \beta + F_z \sin \alpha \cos \beta) \\ \frac{1}{mV \cos \beta}(-F_x \sin \alpha + F_z \cos \alpha) + q - (p \cos \alpha + r \sin \alpha) \tan \beta \\ \frac{1}{mV}(-F_x \cos \alpha \sin \beta + F_y \cos \beta - F_z \sin \alpha \sin \beta) - r \cos \alpha + p \sin \alpha \end{array} \right) \\ \left(\begin{array}{ccc} I_x & -I_{xy} & -I_{xz} \\ -I_{xy} & I_y & -I_{yz} \\ -I_{xz} & -I_{yz} & I_z \end{array} \right)^{-1} \left(\begin{array}{c} M_x + (I_y - I_z)qr + I_{xz}pq + I_{yz}(q^2 - r^2) - I_{xy}pr \\ M_y + (I_z - I_x)pr + I_{xy}qr + I_{xz}(r^2 - p^2) - I_{yz}pq \\ M_z + (I_x - I_y)pq + I_{yz}pr + I_{xy}(p^2 - q^2) - I_{xz}qr \end{array} \right) \end{pmatrix} \quad (1)$$

where the velocity vector elements u , v and w are replaced by magnitude and angles: $V = \sqrt{u^2 + v^2 + w^2}$, $\tan \alpha = w/u$, $\tan \beta = v/\sqrt{u^2 + w^2}$ and where nose forward flight is assumed so that $u > 0$. These full state equations will be used for simulations¹⁵, including non-linear aerodynamic forces and moments depending on the missile state.

When designing the controllers a linear approximation to Eq. (1) will be utilized. Using linear assumptions in aerodynamics⁸ ‘ C_{xx} ’, an assumption of constant vehicle airspeed and defining dynamic pressure as $q_d = \rho V^2 / 2$, the following linearized pitch dynamics⁸ are achieved:

$$\begin{pmatrix} \dot{\alpha} \\ \dot{q} \end{pmatrix} = A_p \begin{pmatrix} \alpha \\ q \end{pmatrix} + B_p \delta_e = \begin{pmatrix} -\frac{q_d S}{mV} C_{N_\alpha} & 1 - \frac{q_d S c}{2mV^2} C_{N_q} \\ \frac{q_d S c}{I_y} C_{m_\alpha} & \frac{q_d S c^2}{2I_y V} C_{m_q} \end{pmatrix} \begin{pmatrix} \alpha \\ q \end{pmatrix} + \begin{pmatrix} -\frac{q_d S}{mV} C_{N_{\delta_e}} \\ \frac{q_d S c}{I_y} C_{m_{\delta_e}} \end{pmatrix} \delta_e \quad (2)$$

After using linear approximations to Eq. (1), as was done for pitch dynamics, the following roll-yaw dynamics⁸ are derived:

$$\begin{pmatrix} \dot{p} \\ \dot{\beta} \\ \dot{r} \end{pmatrix} = A_y \begin{pmatrix} p \\ \beta \\ r \end{pmatrix} + B_y \begin{pmatrix} \delta_a \\ \delta_r \end{pmatrix} = \begin{pmatrix} \frac{q_d S b^2}{2I_x V} \left(C_{l_p} + \frac{I_{xz}}{I_z} C_{n_p} \right) & \frac{q_d S b}{I_x} \left(C_{l_\beta} + \frac{I_{xz}}{I_z} C_{n_\beta} \right) & \frac{q_d S b^2}{2I_x V} \left(C_{l_r} + \frac{I_{xz}}{I_z} C_{n_r} \right) \\ -\frac{q_d S b}{2mV^2} C_{c_p} & -\frac{q_d S}{mV} C_{c_\beta} & -1 - \frac{q_d S b}{2mV^2} C_{c_r} \\ \frac{q_d S b^2}{2I_z V} \left(C_{n_p} + \frac{I_{xz}}{I_x} C_{l_p} \right) & \frac{q_d S b}{I_z} \left(C_{n_\beta} + \frac{I_{xz}}{I_x} C_{l_\beta} \right) & \frac{q_d S b^2}{2I_z V} \left(C_{n_r} + \frac{I_{xz}}{I_x} C_{l_r} \right) \end{pmatrix} \begin{pmatrix} p \\ \beta \\ r \end{pmatrix} + \begin{pmatrix} \frac{q_d S b}{I_x} \left(C_{l_{\delta_a}} + \frac{I_{xz}}{I_z} C_{n_{\delta_a}} \right) & \frac{q_d S b}{I_x} \left(C_{l_{\delta_r}} + \frac{I_{xz}}{I_z} C_{n_{\delta_r}} \right) \\ -\frac{q_d S}{mV} C_{c_{\delta_a}} & -\frac{q_d S}{mV} C_{c_{\delta_r}} \\ \frac{q_d S b}{I_z} \left(C_{n_{\delta_a}} + \frac{I_{xz}}{I_x} C_{l_{\delta_a}} \right) & \frac{q_d S b}{I_z} \left(C_{n_{\delta_r}} + \frac{I_{xz}}{I_x} C_{l_{\delta_r}} \right) \end{pmatrix} \begin{pmatrix} \delta_a \\ \delta_r \end{pmatrix} \quad (3)$$

System inputs are control surface deflections δ_a , δ_e and δ_r which are manipulated by actuators modeled by second-order systems with limits in angular rate and angular position.

III. Reference system design

The linear system derived for pitch and roll-yaw motion will be used to create reference systems with desired dynamics. Reference systems are needed for most adaptive control designs such as in^{1,2}. Open-loop system dynamics achieved for aerial vehicles of today are often poorly damped and sometimes deliberately unstable so they cannot be used as a reference for desired dynamics straight away.

Reference system creation is done by designing a linear state feedback which places the poles of the system so that desired, yet achievable, dynamics are realized. This way an arbitrary aerial vehicle, with dynamics that can be linearized, can be applied by this method.

This linear state feedback will also form an inner loop together with the augmented adaptive controller. This, together with feedforward from reference, will create a system that nominally does not activate the adaptive controller. This is the case since the reference model in the adaptive controller and the system, as it appears to the adaptive controller, nominally has equal dynamics. The adaptive controller will then act only on (unavoidable) imperfections in the system consisting of the flight dynamics, controlled by the state feedback, aided by the feedforward.

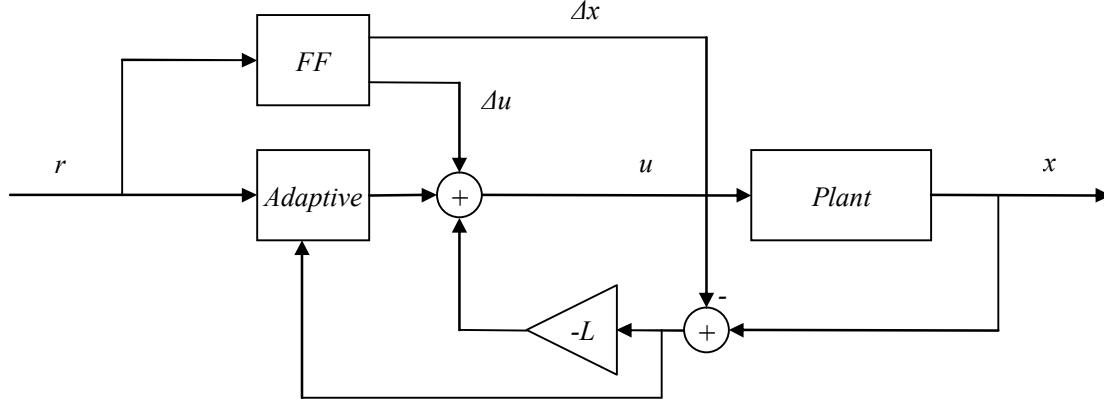

Figure 2 Controller built up by: Feedforward from reference (*FF*), Adaptive controller and linear state feedback (*L*).

A. Pitch dynamics reference system

The goal is to find a parameter, related to the nominal flight dynamics, which will make it possible to scale reference systems suitable to the present flight conditions. First a fundamental characteristic of the pitch motion is found. Then this characteristic is used to decide a linear state feedback that creates a reference system that is fast and yet reachable. To find fundamental characteristic of the pitch motion, the moment coefficient related to angle of attack is set to zero.

With $C_{m_\alpha} = 0$ in Eq. (2) the inverse of the two diagonal elements in A_p become the eigenvalues of the matrix and equivalently the poles of the system. Now two time constants are defined in relation to these poles as follows:

$$T_{sp} = \left(\frac{q_d S}{mV} C_{N_\alpha} \right)^{-1} \quad \tau_{op} = - \left(\frac{q_d S c^2}{2I_y V} C_{m_q} \right)^{-1} \quad (4)$$

These time constants define the position of the systems two poles when $C_{m_\alpha} = 0$ as seen in the Fig. 3 root locus.

As C_{m_α} goes to large negative values the poles will meet and form a complex-conjugated pair that follows the dashed line with negative and positive imaginary values. As C_{m_α} goes to positive values, one pole goes in to the right half-plane (destabilizing the configuration) and the other goes further into the left half-plane. Using linear state feedback from α to δ_e can be seen as manipulating the value of C_{m_α} to move pole positions and when adding feedback from angular rate q the poles can be placed even more arbitrary.

This fundamental line, in-between the poles, is defined by its distance to the imaginary axis and gives information about the rise-time that can be expected from the system. The distance to the imaginary axis is $\Delta = (T_{sp}^{-1} + \tau_{op}^{-1})/2$ and this distance will be used to place poles for the reference system later on.

Possible rise-time of the system is of course also defined by the available control signal amplitude, in this case aerodynamic control surface deflection. It is most often the case and it is assumed here, that in these aeronautical applications, the control surface deflection amplitude and efficiency is designed from the start to be sufficient for normal maneuver amplitudes, so that the poles in Fig. 3 dictate possible system performance. Also actuator dynamics play a role in possible speedup of system dynamics. It is assumed that actuator dynamics are faster than the flight dynamics poles that are placed by state feedback in these applications, so they can be neglected in a large part of the airspeed and altitude envelope. In regions of the envelope with high dynamic pressure, actuator dynamics could limit the possible reference bandwidth.

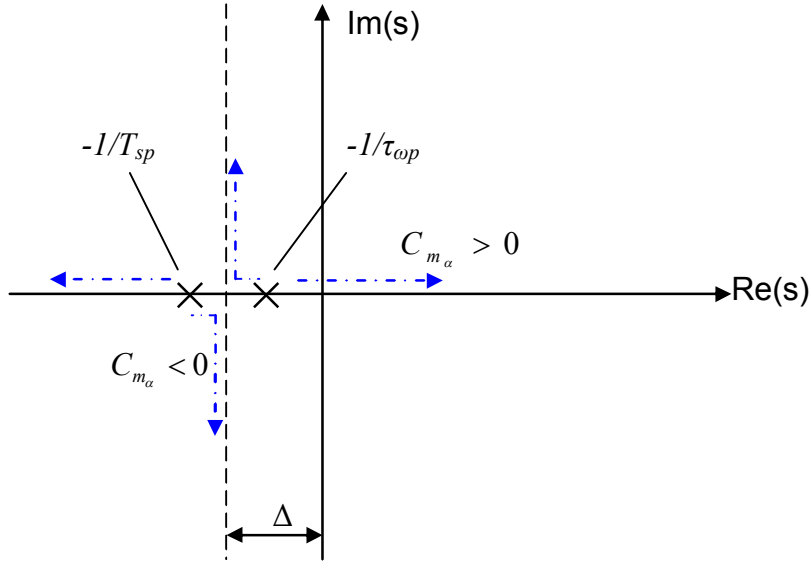

Figure 3 Root locus of pitch dynamics as pitch moment coefficient C_{m_α} goes from 0 to negative and from 0 to positive values.

B. Pitch dynamics with linear state feedback

A relevant reference system will be created by using the nominal dynamics with an applied state feedback. This feedback should give fast dynamics while respecting the natural dynamics set by the physical design. A feedback gain will be created by speeding up the system using the distance Δ Fig. 3 and scale this “angular frequency” by a parameter denoted p_{factor} .

Linear state feedback will be applied:

$$\delta_e = -L_p \begin{pmatrix} \alpha \\ q \end{pmatrix} = -(l_1 \quad l_2) \begin{pmatrix} \alpha \\ q \end{pmatrix} \quad (5)$$

The closed-loop system will have the following state space matrix A_{mp} which will be given desired eigenvalues:

$$A_{mp} = A_p - B_p L_p = \begin{pmatrix} a_{11} - b_1 l_1 & a_{12} - b_1 l_2 \\ a_{21} - b_2 l_1 & a_{22} - b_2 l_2 \end{pmatrix} \quad (6)$$

The poles given by $-1/T_{sp}$ and $-1/\tau_{\omega_p}$ are moved from their original positions (black), to positions further into the left half plane (blue), as illustrated in Fig. 4.

This task is started by expressing dynamics, in the parameters ω_{0p} and ζ_p for pole assignment (in Fig. 4). This new parameterized system is expressed in state-space form and it will be possible to decide how to choose an L_p that gives the desired dynamics by identifying elements in A_{mp} . Parameters will also be added to express zeros and steady-state gains of the system, denoted ω_{1p} and τ_{sp} .

A parameter K_{gp} will express the steady-state gain from input δ_e to output α . Steady-state gain between states α and q is handled by the parameter τ_{sp} . This parameter, the so called turning rate time constant⁹, will be unaffected by feedback and is closely related to T_{sp} in Eq. (4):

$$\tau_{sp} = T_{sp} \left(1 - \frac{C_{m\alpha} C_{N\delta_e}}{C_{N\alpha} C_{m\delta_e}} \right)^{-1} \quad (7)$$

where the factor scaling T_{sp} set the trim gain or trim loss depending on the magnitude and positions at which the force due to angle of attack and control surfaces act on the body.

A parameter ω_{1p} corresponding to a plant zero will be unaffected by feedback and it is related to elements in A_p

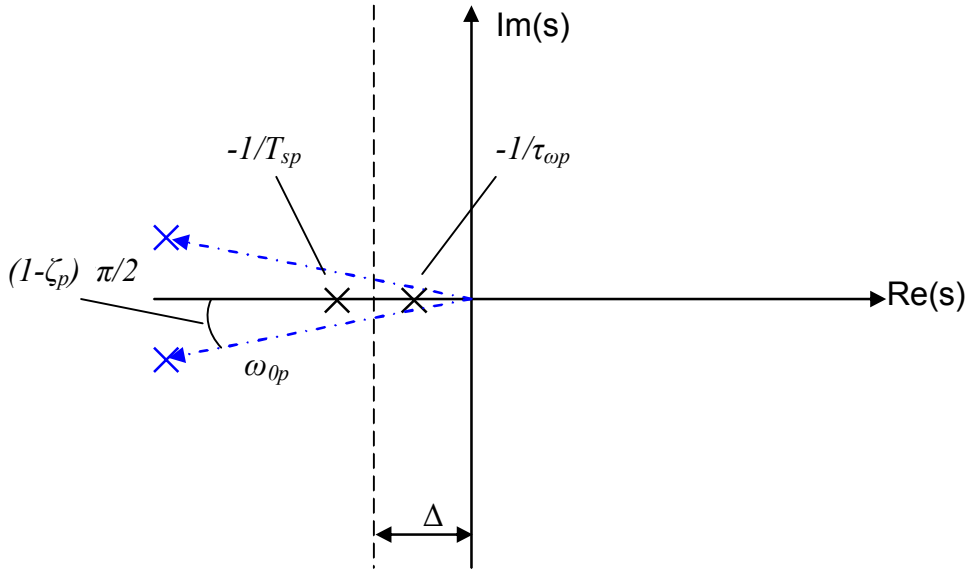

Figure 4. Poles of the reference system (blue), moved by the linear state feedback to desired position using the parameter Δ which is set by vehicle fundamentals.

and B_p according to:

$$\omega_{1p} = \frac{a_{12}b_2}{b_1} - a_{22} \quad (8)$$

Expressed in these parameters, state-space for the pitch motion becomes:

$$\begin{pmatrix} \dot{\alpha} \\ \dot{q} \end{pmatrix} = k_p \begin{pmatrix} -\frac{1}{\tau_{sp}} + \frac{1}{\omega_{1p}} \left(\frac{2\zeta_p \omega_{0p}}{\tau_{sp}} - \omega_{0p}^2 \right) & 1 - \frac{1}{\omega_{1p}} \left(2\zeta_p \omega_{0p} - \frac{\omega_{0p}^2}{\omega_{1p}} \right) \\ \frac{2\zeta_p \omega_{0p}}{\tau_{sp}} - \omega_{0p}^2 - \frac{1}{\tau_{sp}^2} & \frac{1}{\tau_{sp}} - 2\zeta_p \omega_{0p} + \frac{\omega_{0p}^2}{\omega_{1p}} \end{pmatrix} \begin{pmatrix} \alpha \\ q \end{pmatrix} \quad (9)$$

$$+ \omega_{0p}^2 K_{gp}^{-1} \begin{pmatrix} 1 \\ \omega_{1p} \\ 1 \end{pmatrix} \delta_e, \quad k_p = \frac{1}{1 - \frac{1}{\omega_{1p} \tau_{sp}}}$$

To get desired dynamics the following expression that scales response is defined:

$$\omega_{0p} = p_{factor} \Delta = p_{factor} \frac{1}{2} \left(\frac{1}{T_{sp}} + \frac{1}{\tau_{ep}} \right) \quad (10)$$

The damping ζ_p , is set to 0.9, a relatively high damping, to avoid introduction of oscillations already in the reference system. This p_{factor} becomes a reference system tuning parameter that will work on fundamentals of the flight dynamics, it will be tuned once and then the current flight condition and airframe configuration will place the poles in suitable positions.

Finally, feedback gains $L_p = (l_1 \ l_2)$ can be determined that will give the desired dynamics::

$$B_p L_p = A_p - A_{mp} = \begin{pmatrix} b_1 l_1 & b_1 l_2 \\ b_2 l_1 & b_2 l_2 \end{pmatrix} \quad (11)$$

The expression in Eq. (11) is over-determined for l_1 and l_2 but thanks to the tailored parameterization in Eq. (8), an L_p that solves the equation exactly will be found. The difference between the system's nominal and desired A -matrix is in the span of the B -matrix.

C. Roll-yaw dynamics with linear state feedback

The roll-yaw feedback is chosen in a similar way to the pitch feedback. That is, fundamental characteristics of the flight dynamics are found and this is used to speed up the dynamics to a desired degree. In roll-yaw there are three poles to be placed. Two poles from yaw motion are similar to the ones in pitch. One additional pole comes from the roll motion, a first-order system with a stable pole.

$$A_{my} = A_y - B_y L_y \quad (12)$$

This expression is again over-determined but a least-squares solution will give a good result for the sought linear state feedback gain L_y .

Two parameters r_{factor} and y_{factor} are defined, corresponding to the p_{factor} in pitch, which will be tuned once and then the three poles of the roll-yaw dynamics will be placed in desired positions.

IV. Feedforward

Feedforward terms will be added to the control signals of the vehicle to compensate for five different effects.

- 1) The feedforward will take into account *deviation moments* due to mass asymmetries.
- 2) Feedforward has been chosen as the method for making it possible to perform a *velocity vector roll*.
- 3) It will also reduce *gravitational forces* influence to angle of attack and sideslip.
- 4) *Aerodynamic drag* will be compensated for by adding thrust through feedforward signals.
- 5) Compensation to counteract *pitch force and moment at zero angle of attack* will be designed.

These effects are mainly nonlinear and with this feedforward compensation the feedback controller will work with a system that is closer to linear as proposed in^{4,5}. Dynamic inversion^{12,6} and backstepping^{13,7} designs use the vehicle angular velocity vector as a virtual control signal to manipulate angle of attack/sideslip, as is done in the design created here.

A. Reference feedforward design

Compensations will be made to get the vehicle angular velocity vector and airspeed correct. By noting that α and β over short periods of time are approximate time integrals of pitch rate q and yaw rate r , desired compensations will be made.

State deviations from the nominal system, which will be created by the feedforward, will be subtracted from measured states before these quantities go to the feedback controllers. The feedforward control signal Δu and the state deviations Δx are incorporated into the overall design as in Fig. 2.

To be able to compensate by feedforward, nominal system state values over time are needed. To get values for body angular velocity vector $\bar{\omega}$ and velocity vector \bar{v} , copies of reference systems for the adaptive controller are used from Eq. (9) and Eq. (12). They mimic the desired system behavior and using state values from reference systems will make this design feedforward. However, estimated Euler angles will be used to compensate gravity, so this will introduce some feedback. Euler angles are one integration level above angular rates so this feedback is slow compared to other effects created by this feedforward.

An alternative would be to design feedback controllers that would compensate for one or several of the effects dealt with in this section. Here, the feedforward approach was chosen instead of feedback. The plant together with

this feedforward will nominally be linear and similar to the reference systems. So the controllers will only need to deal with imperfections from this ideal assumption. This is suitable for adaptive controllers since they use a reference system and are designed to reduce deviation from this reference system. By adding feedforward the parameter interval that the adaptive controllers will have left for dealing with deviation from reference system behavior will be larger using this design. A structure will be created in which the adaptive controller output will be close to zero if no model errors are at hand, since non-linearities are compensated for, leaving the adaptive controller with signals that are exponential time functions, corresponding to what the reference systems of the adaptive controller were designed for.

In order to generate appropriate feedforward, nominal values for how the inputs affect the system are needed. This input gain and other aerodynamic dependencies of this feedforward design will assume that a linearization can be done. The linear part of generating moments by control surface deflection $M_\delta \bar{\delta}$ obeys the equation:

$$\bar{M} = \bar{M}_0 + M_\delta \bar{\delta} = \bar{M}_0 + q_d S \begin{pmatrix} bC_{l\delta_a} & bC_{l\delta_e} & bC_{l\delta_r} \\ cC_{m\delta_a} & cC_{m\delta_e} & cC_{m\delta_r} \\ bC_{n\delta_a} & bC_{n\delta_e} & bC_{n\delta_r} \end{pmatrix} \begin{pmatrix} \delta_a \\ \delta_e \\ \delta_r \end{pmatrix} \quad (13)$$

where \bar{M}_0 is a collection of moments generated by other parts than control surfaces (and nonlinear effects of control surface deflection). The matrix M_δ is invertible since creating large diagonal elements in this matrix is essential to aerodynamic control surface design. Some non-diagonal elements in M_δ are usually zero, since there are usually no linear couplings between for example pitch elevator and roll moment.

1. Deviation moments

Deviation moments can be directly compensated for by feedforward since change in angular velocity follow Euler's equation: $\dot{\bar{\omega}} = I_r^{-1}(\bar{M} - \bar{\omega} \times I_r \bar{\omega})$. So the deviation moment term $\bar{\omega} \times I_r \bar{\omega}$ is added directly to the moments \bar{M} which can be directly manipulated by feedforward according to Eq. (13).

This means that deviation moments can be compensated by adding the following term to the actuator demand:

$$\Delta u_1 = M_\delta^{-1}(\bar{\omega} \times I_r \bar{\omega}) \quad (14)$$

Here $\bar{\omega}$ elements are outputs p , q and r from reference systems with the same demands as the feedback controller and with the added effects of compensations created from velocity vector roll rate and gravitation.

This deviation moment feedforward term Eq. (14) will not create any delta effects in states Δx so the first term in this sum is zero:

$$\Delta x_1 = \bar{0} \quad (15)$$

2. Velocity vector roll rate

Compensations will be created so that the motion will be a velocity vector roll or a "bank to turn" as it also is called (in contrast to e.g. skid to turn). A demanded roll rate will be performed *around the velocity vector as opposed to the body x-axis* so that angle of attack/sideslip will follow the linear dynamics that are desired. Roll rotation around an axis close to the body x-axis in Fig. 1 would otherwise be the case since the moment that roll control surfaces naturally create is around body x-axis. This rotation solely around body x-axis would create severe nonlinear cross-couplings between α and β which are undesired in many applications.

This change of angular velocity vector, from body x-axis to velocity vector, will be accomplished by adding control surface deflections that make the angular velocity vector, corresponding to a roll rate demand, parallel to the velocity vector. The magnitude of this additional angular velocity vector will be such that the projection onto the body x-axis will be the demanded roll rate. When the roll angular velocity vector and velocity vector are parallel, small change in velocity vector components due to roll rate will be at hand, since the cross product will ideally be zero in Newton's second law $\dot{\bar{v}} = m^{-1}\bar{F} - \Delta\bar{\omega} \times \bar{v}$.

So the first element p in $\Delta\bar{\omega}$ will be created by the roll controller and the other two elements corresponding to additional pitch rate Δq_2 and yaw rate and Δr_2 will be created by feedforward so that this vector becomes parallel to \bar{v} . By expressing the velocity vector \bar{v} in u , α and β , the resulting angular velocity will be expressed in p , α and β , which is desired, since these are the states that are used for feedforward.

To achieve a pure bank to turn, the following cross product should be zero:

$$\Delta \bar{\omega} \times \bar{v} = \begin{pmatrix} p \\ \Delta q_2 \\ \Delta r_2 \end{pmatrix} \times \begin{pmatrix} u \\ v \\ w \end{pmatrix} = \begin{pmatrix} p \\ \Delta q_2 \\ \Delta r_2 \end{pmatrix} \times \begin{pmatrix} u \\ u \tan \beta / \cos \alpha \\ u \tan \alpha \end{pmatrix} = \bar{0} \quad (16)$$

so Δq_2 and Δr_2 are set to create an angular velocity vector parallel to the velocity vector:

$$\begin{pmatrix} p \\ \Delta q_2 \\ \Delta r_2 \end{pmatrix} \times \begin{pmatrix} u \\ v \\ w \end{pmatrix} = \begin{pmatrix} p \\ p \tan \beta / \cos \alpha \\ p \tan \alpha \end{pmatrix} \times \begin{pmatrix} u \\ u \tan \beta / \cos \alpha \\ u \tan \alpha \end{pmatrix} = \bar{0} \quad (17)$$

This change in Δq_2 and Δr_2 will be done by altering $\dot{\bar{\omega}}$ using Eq. (13) through changing the moment $\bar{M} = \bar{M}_0 + M_\delta \bar{\delta}$ in $\dot{\bar{\omega}} = I_r^{-1}(\bar{M} - \bar{\omega} \times I_r \bar{\omega})$. So using time derivatives of Δq_2 and Δr_2 the following addition to the control signal:

$$\Delta u_2 = M_\delta^{-1} I_i \frac{d}{dt} \begin{pmatrix} 0 \\ p \tan \beta / \cos \alpha \\ p \tan \alpha \end{pmatrix} \quad (18)$$

will accomplish the proper compensation. This addition to the control signal will create a desired addition to $\dot{\bar{\omega}}$, which will be integrated by flight dynamics over time to achieve the desired Δq and Δr .

Time derivation of Δq_2 and Δr_2 in Eq. (18) could be approximated by a transfer function:

$$\frac{\omega_a s}{s + \omega_a} \quad (19)$$

where ω_a is the bandwidth of the actuator system. This transfer function will create time derivatives of signals up to an angular frequency close to ω_a , any effort to feed signals forward beyond that bandwidth will be attenuated by the actuator anyway.

The added angular velocity due to this feedforward is:

$$\Delta x_2 = \begin{pmatrix} 0 \\ \Delta q_2 \\ \Delta r_2 \end{pmatrix} = \begin{pmatrix} 0 \\ p \tan \beta / \cos \alpha \\ p \tan \alpha \end{pmatrix} \quad (20)$$

so this quantity are subtracted from system states before being used in the controller. If not, the feedback part of the controller would reduce these elements Δq_2 and Δr_2 that are created by feedforward.

This compensation will create forces \bar{F} that will disturb the angle of attack/sideslip but these deviations will be relatively small, since forces generated by control surface deflection and angular rates are small compared to the ones generated by e.g. angle of attack/sideslip.

3. Gravitation effects on angle of attack and sideslip

Compensation will be made so that the *change* in projection of the gravity vector onto the body system will not affect the control objective. In other words, even though the attitude changes over time and the force due to gravity is inertial, workload will be taken off controllers in keeping the angle of attack/sideslip constant. No effort will be made here to counteract the constant effect of gravity, (for example to maintain altitude).

Angle of attack/sideslip derivative expressions will give input to what needs to be added to body rates q and r to compensate for gravity:

$$\begin{pmatrix} \dot{\alpha} \\ \dot{\beta} \end{pmatrix} = \begin{pmatrix} q - \frac{q_d S}{mV} C_N - p \tan \beta + \frac{g}{V} \cos \Phi \cos \theta \\ -r - \frac{q_d S}{mV} C_C + p \sin \alpha + \frac{g}{V} \sin \Phi \cos \theta \end{pmatrix} \quad (21)$$

To compensate for that gravity will affect α and β , the same method as for a velocity vector roll is used. Additional rates Δq_3 and Δr_3 are used as virtual control signals to keep angle of attack/sideslip rates follow the linear dynamics that is desired.

Change in Δq_3 and Δr_3 will as for a velocity vector roll be done by altering $\dot{\omega}$. So setting Δq_3 and Δr_3 to the corresponding last term in Eq. (21) and generating time derivatives of these quantities, the following addition to the control signal:

$$\Delta u_3 = M_\delta^{-1} I_i \frac{d}{dt} \frac{g}{V} \begin{pmatrix} 0 \\ -\cos \Phi \cos \theta \\ \sin \Phi \cos \theta \end{pmatrix} \quad (22)$$

will compensate for gravity effects coming from that the attitude changes over time. Time derivation could again be approximated by Eq. (19).

The added pitch and yaw rates due to this gravity feedforward will be:

$$\Delta x_3 = \begin{pmatrix} 0 \\ \Delta q_3 \\ \Delta r_3 \end{pmatrix} = \frac{g}{V} \begin{pmatrix} 0 \\ -\cos \Phi \cos \theta \\ \sin \Phi \cos \theta \end{pmatrix} \quad (23)$$

4. Drag and gravity effects on airspeed

Aerodynamic drag effects will be compensated by adding propulsion thrust so that airspeed is maintained even though the motion effectuates angle of attack/sideslip demands. When angle of attack/sideslip is generated airspeed is reduced due to induced drag. Induced drag comes from that a large part of aerodynamic body forces ($q_d S C_C$ and $q_d S C_N$) are generated in a plane perpendicular to the body x-axis, not perpendicular to the velocity vector. Because of this property a significant part of the aerodynamic force projects onto the negative direction of the velocity vector and create induced drag. Also the gravity vector project onto the direction of the velocity vector and will be compensated for by feedforward thrust alteration.

According to Newton's second law the change in airspeed V over time follows:

$$\dot{V} = \frac{1}{m} (F_x \cos \alpha \cos \beta + F_y \sin \beta + F_z \sin \alpha \cos \beta) \quad (24)$$

where force elements are:

$$\begin{aligned} F_x &= T - q_d S C_T - mg \sin \theta \\ F_y &= -q_d S C_C + mg \sin \Phi \cos \theta \\ F_z &= -q_d S C_N + mg \cos \Phi \cos \theta \end{aligned} \quad (25)$$

By adding a feedforward term to the thrust T denoted ΔT , aerodynamic and gravity effects can be reduced. It is assumed that the nominal thrust is set to counteract the zero incidence drag, $q_d S C_T$. So ΔT will compensate for the other terms that affect airspeed in Eq. (24).

The following addition ΔT to the thrust demand will nominally keep airspeed constant:

$$\Delta T = q_d S \left(C_C \frac{\tan \beta}{\cos \alpha} + C_N \tan \alpha \right) + mg \frac{\sin \gamma}{\cos \alpha \cos \beta} \quad (26)$$

where γ is the climb angle, the elevation angle of the velocity vector above the horizontal plane (which can be expressed in Euler angles and angle of attack/sideslip if needed).

5. Compensation force and moment at zero angle of attack

At zero angle of attack there are usually small aerodynamic forces and moments acting in the pitch channel due to asymmetry of the vehicle above and underneath the xz-plane of the body. The zero force coefficient C_{N_0} and the moment coefficient C_{m_0} will be compensated so that zero angle of attack is maintained.

If zero α is desired as steady state in:

$$\begin{pmatrix} \dot{\alpha} \\ \dot{q} \end{pmatrix} = \begin{pmatrix} q - \frac{q_d S}{mV} \left(C_{N_0} + C_{N_\alpha} \alpha + C_{N\delta_e} \delta_e + \frac{c}{2V} C_{N_q} q \right) \\ \frac{q_d S b}{I_y} \left(C_{m_0} + C_{m_\alpha} \alpha + C_{m\delta_e} \delta_e + \frac{c}{2V} C_{m_q} q \right) \end{pmatrix} \quad (27)$$

the solution in pitch rate q and elevator δ_e becomes:

$$\begin{pmatrix} q_0 \\ \delta_{e_0} \end{pmatrix} = \begin{pmatrix} 1 - \frac{q_d S c}{2mV^2} C_{N_q} & -\frac{q_d S}{mV} C_{N\delta_e} \\ \frac{q_d S c}{2I_y V} C_{m_q} & \frac{q_d S c}{I_y} C_{m\delta_e} \end{pmatrix}^{-1} \begin{pmatrix} \frac{q_d S}{mV} C_{N_0} \\ -\frac{q_d S c}{I_y} C_{m_0} \end{pmatrix} \quad (28)$$

so the constant feedforward control signal to maintain zero α and the constant deviation in pitch angular rate becomes:

$$\Delta u_5 = \begin{pmatrix} 0 \\ \delta_{e_0} \\ 0 \end{pmatrix} \quad \Delta x_5 = \begin{pmatrix} 0 \\ q_0 \end{pmatrix} \quad (29)$$

B. Feedforward simulations

Simulations in a six degrees of freedom model of a pitch-unstable fighter jet with and without feedforward compensations are presented. Demands are a sequence of angle of attack α and roll rates p .

The addition of feedforward signals will be applied to feedback controllers of two different types. A linear state feedback controller to which integral action is added, by use of reference systems according to $H_m(s) = C(sI - A_m)^{-1} B_m$ and integrating control output error from these reference signals over time. The gain for the error integral state is chosen as the reference system steady state gain $K_g = H_m(0)$. So the state-feedback controller with integral action uses the following gain from the reference r and feedback law from states x and output y :

$$u(s) = K_g r(s) - Lx(s) - K_g \frac{1}{s} (H_m(s) K_g r(s) - y(s)) \quad (30)$$

The second feedback controller is a linear state feedback that has been augmented by an L1 adaptive controller of piecewise constant type. The L1 control law of piecewise constant type can be expressed as¹¹:

$$u(s) = K_g r(s) - Lx(s) - K_g D_s(s) \frac{1}{s} (K_g r(s) - H_m^{-1}(s) y(s)) \quad (31)$$

These two control laws in will be compared in simulations, as they are used with and without the aid of feedforward.

C. Scenario

Demands will create changes in angle of attack and at the same time roll rotate the vehicle to different roll angles as viewed in Fig. 5. Angle of sideslip is demanded to zero throughout maneuvers. To keep α and p at the demanded values while keeping β small is the major task that the controller will work hard to accomplish in scenarios like these.

An altitude of about 1000m and an airspeed corresponding to M0.6 will be kept roughly constant throughout the maneuver sequence. This way *changes* during the simulation to dynamic pressure q_d will not affect results to any large extent (however controller assumptions of altitude and airspeed are erroneous in runs with perturbations). Observed phenomena will be due to effects created by rapid maneuvering and deviations from nominal dynamics.

1. Simulations start by pulling 10° of angle of attack (from 0°), as indicated in Fig. 5.
2. A roll rate p of $180^\circ/s$ is demanded for a time period of $0.5s$ so that a roll angle of 90° is obtained.
3. The α demand is decreased to 0° at the same time as a roll rate of $-180^\circ/s$ is demanded for $0.5s$ so that the roll angle becomes 0° .
4. Then α is increased to 10° at the same time as a roll rate of $-180^\circ/s$ is demanded for $0.5s$ to a roll angle of -90° .
5. Now α is decreased to 5° at the same time as a roll rate of $180^\circ/s$ is demanded for $0.5s$ to a roll angle of 0° .
6. Finally α is maintained at 5° and a roll rate of $360^\circ/s$ is demanded for $1s$ so that a full roll revolution is made.

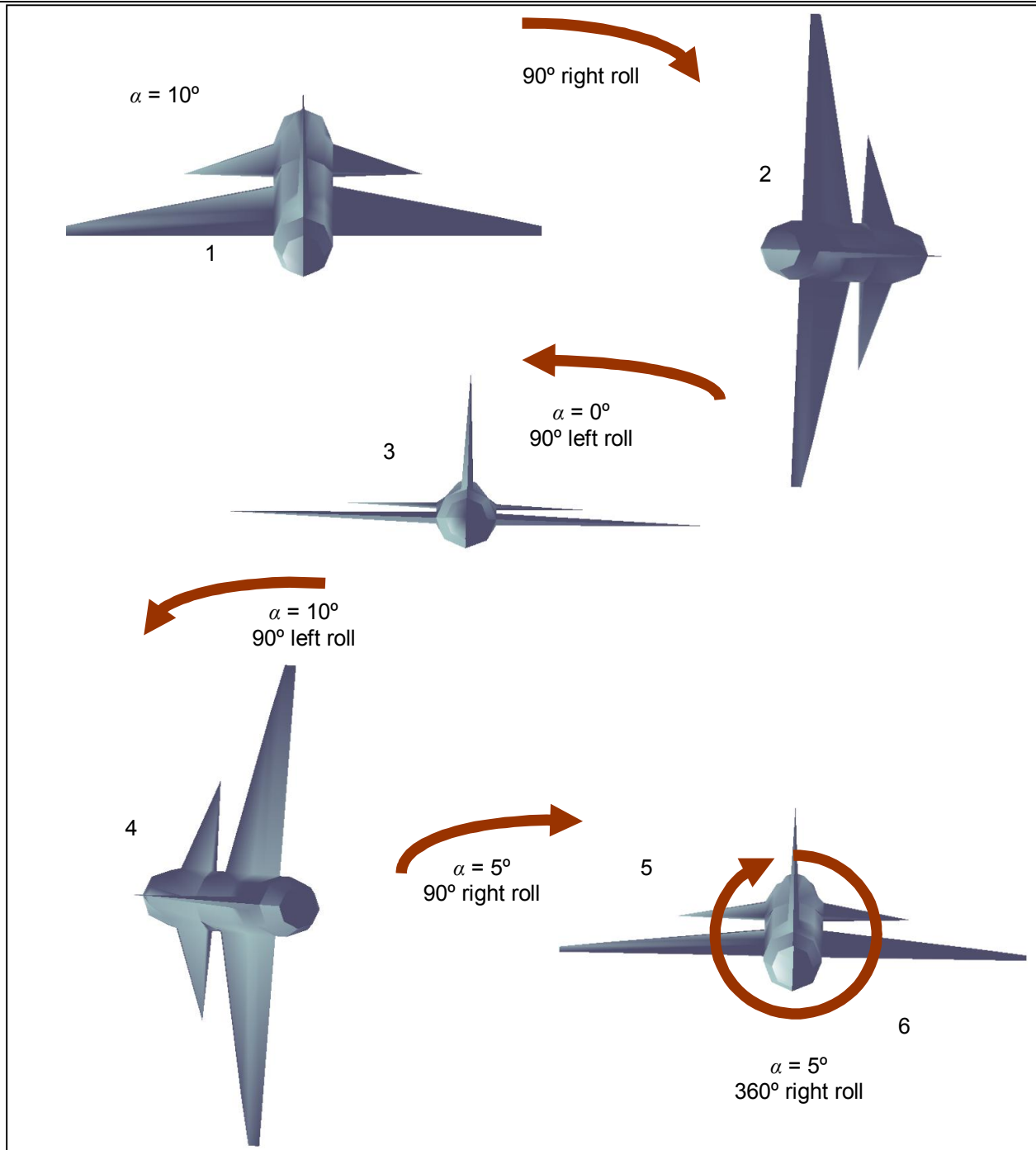

Figure 5 Schematic aircraft, rear view showing sequence of maneuvers performed in simulations.

Since roll rate demands are made open-loop with respect to achieved roll angle, they are just step functions of suitable time periods; a small roll addition is made to get roll angles that are even quarters of a turn.

D. Simulation settings and results

Three settings in the model have been simulated with a full 6DOF-model, including non-linear effects:

Nominal settings:

All parameters were nominal, which correspond to values assumed when controller design was made. The feedforward signals are calculated and included in the total controller design.

No feedforward applied:

Feedforward signals were not added to the control signal. Controllers needed to compensate for nonlinear couplings without aid from feedforward based on reference signal inputs. One effect was that a demanded roll rate creates large couplings between angle of attack and sideslip. Also effects of that the airframe naturally rotates around its principal mass inertia axis, as well as gravity effects, were left to controllers without aid from feedforward.

Parameter perturbations:

Error in parameter assumptions were created by using normally distributed values. Pre-sampled parameter realizations were saved and used for simulations so that comparisons can be made between runs. These values were then used to perturb parameter settings relative nominal values. Start position and velocity were varied so that the 1σ relative error became 10%. Atmospheric parameters were varied by 5%. Mass and mass inertia properties were varied by 5% and aerodynamic parameters by 20%. Center of gravity position related to the wing cord was varied by 2% and actuator bandwidth, rate limit and damping by 10%. The parameter realization for which simulations are presented was a challenging one; it made the needed control effort large. *Controller feedforward compensations were made with nominal parameter values*, making this a valid check also for feedforward robustness to perturbations.

For each of the seven different settings above, two simulations were made and presented one figure on top of the other. One run is plotted for L1-control augmented to a state feedback. One run is plotted for state feedback acting on its own, including integral action.

Four subplots are presented for each simulation in Fig. 6 to Fig. 11. Demands in angle of attack/sideslip and roll rate (α_d, β_d and p_d) are dashed lines, effectuated signals are solid lines in the following subplot layout:

<p>Subplot 1: angle of attack α (blue) and angle of sideslip β (green).</p>	<p>Subplot 2: body rates p, q and r (blue green red)</p>
<p>Subplot 3: demanded and effectuated pitch control signals δ_e.</p>	<p>Subplot 4: demanded and effectuated roll and yaw control signals δ_a and δ_r (blue green).</p>

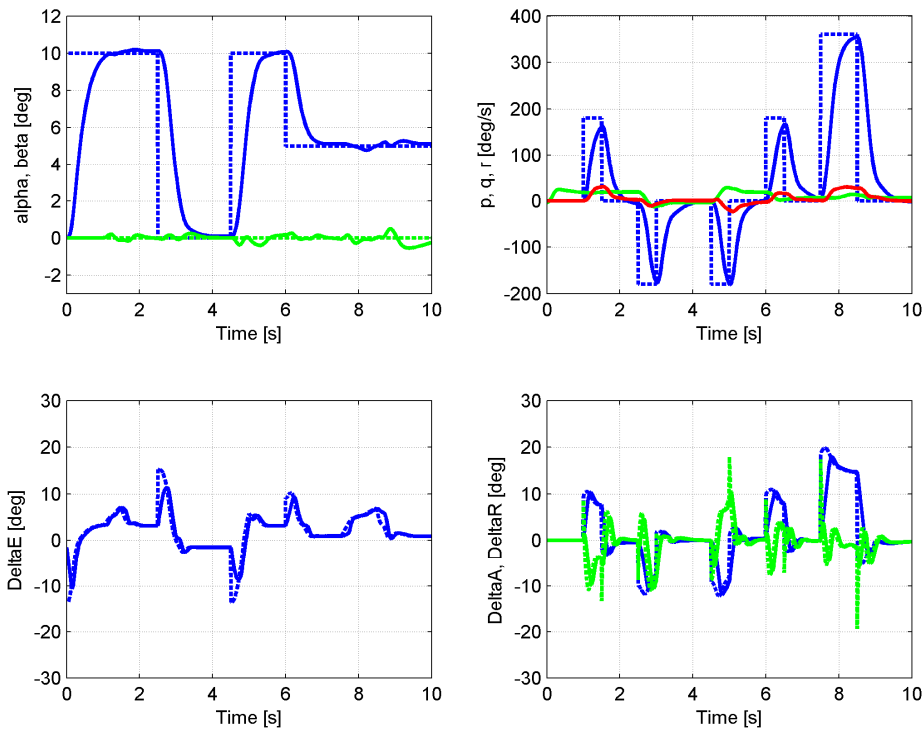

Figure 6 Simulation of the system with the L1-controller, for nominal plant.

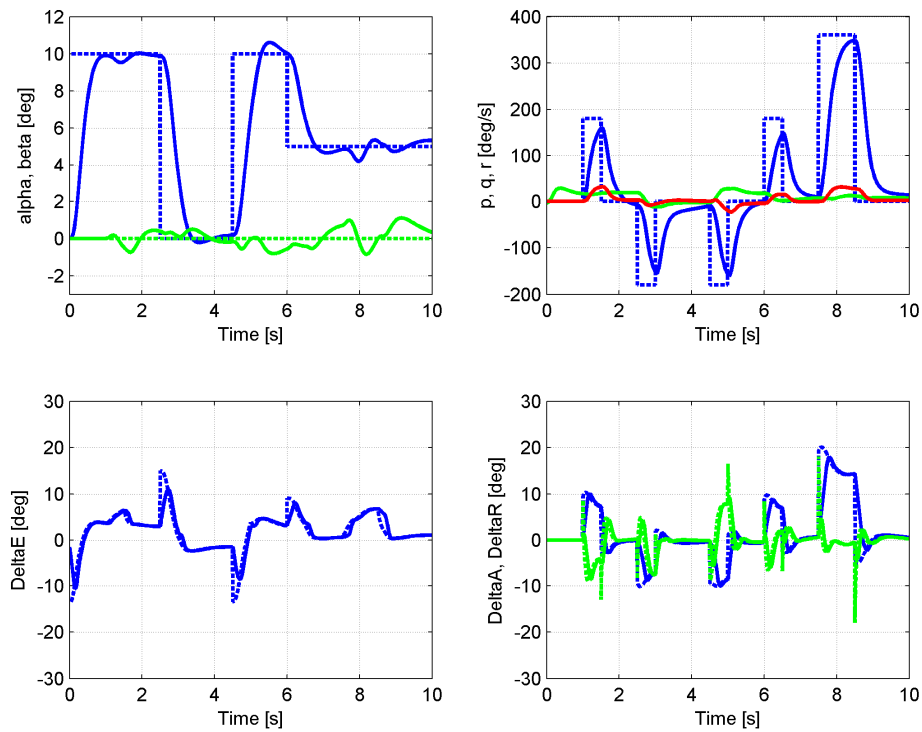

Figure 7 Simulation of the system with the state-feedback controller, for nominal plant.

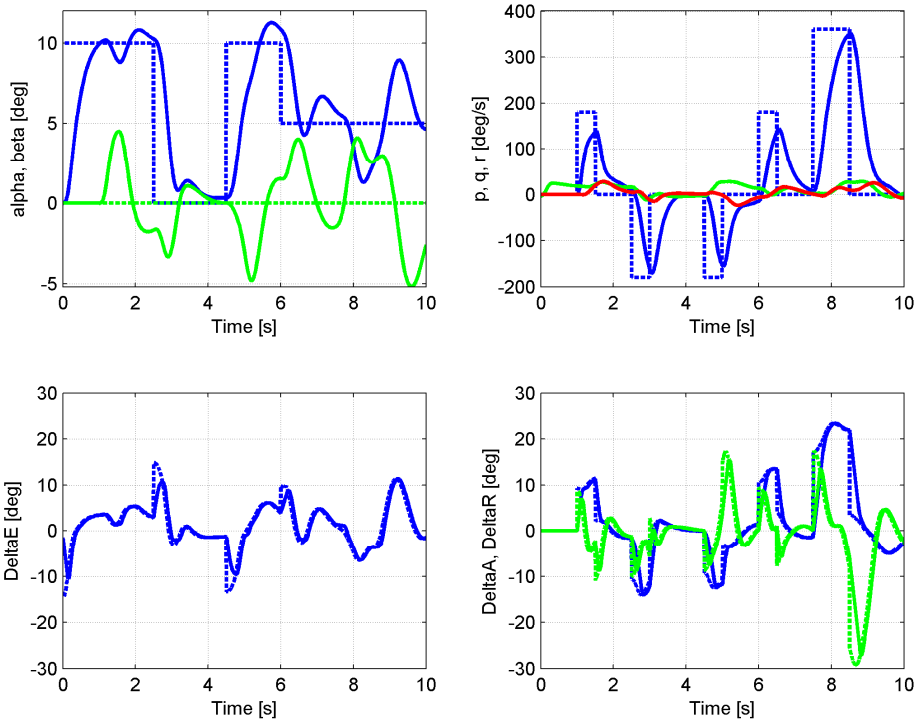

Figure 8 Simulation of the system with the L1-controller, without feedforward from reference.

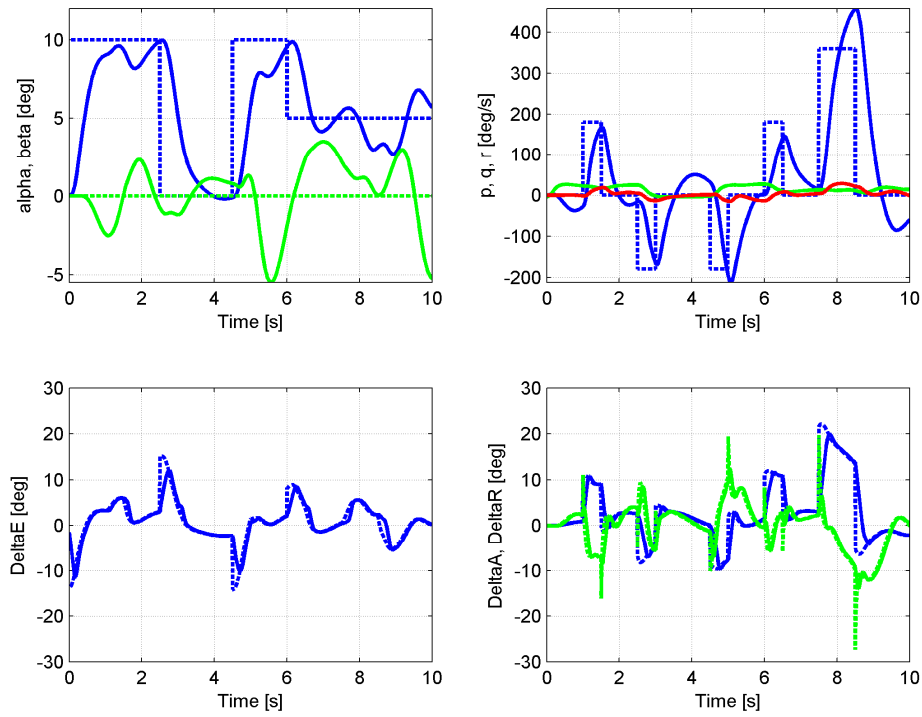

Figure 9 Simulation of the system with the state-feedback controller, without feedforward from reference.

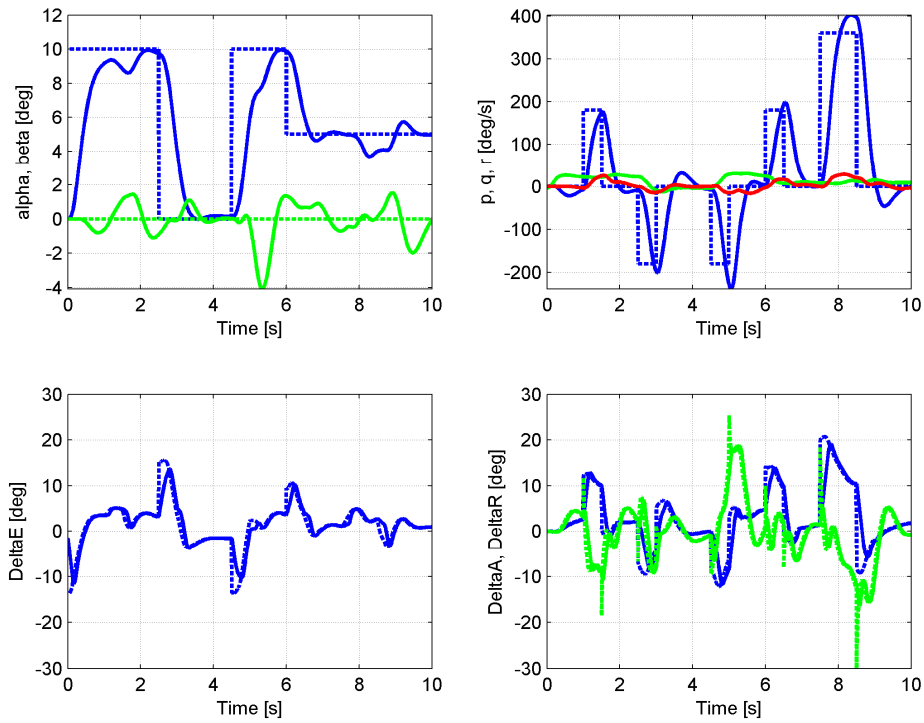

Figure 10 Simulation of the system with the L1-controller, perturbed parameters, see section D.

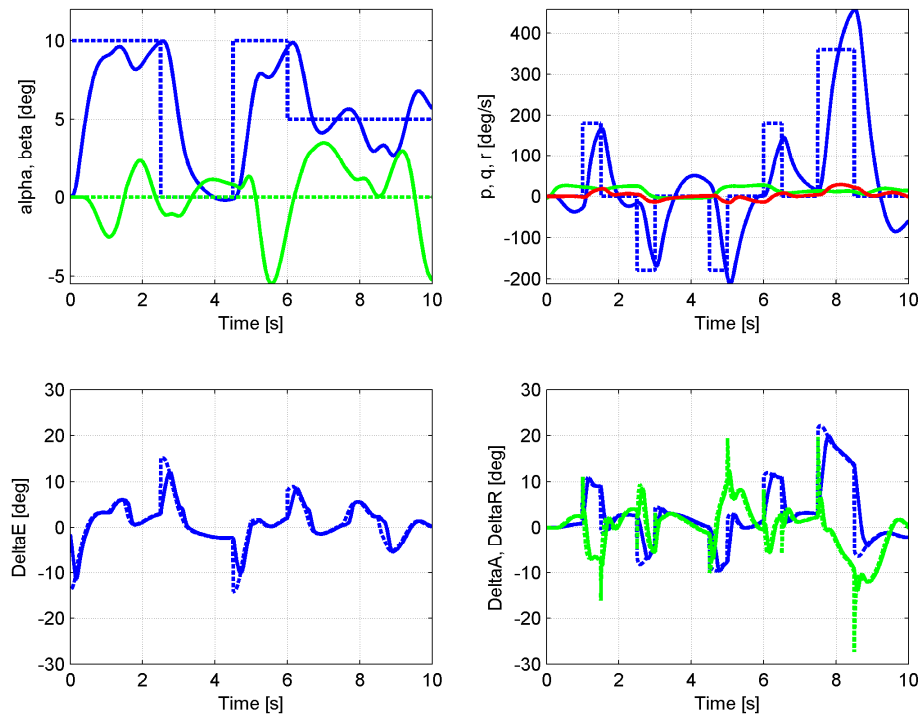

Figure 11 Simulation of the system with the state-feedback controller, perturbed parameters, see section D.

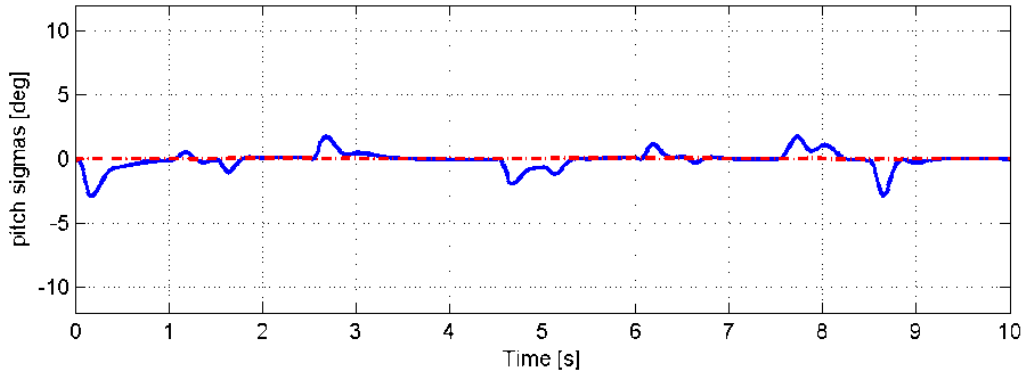

Figure 12 Parameter estimates $\hat{\sigma}_1$ and $\hat{\sigma}_2$ of L1-controller for nominal case.

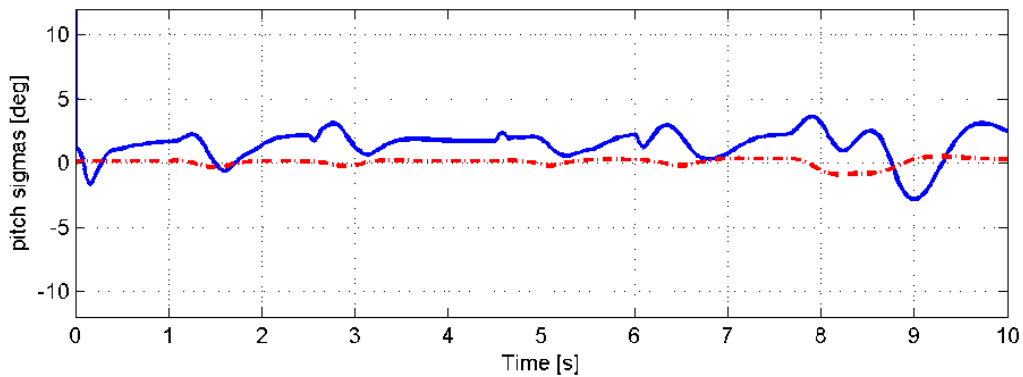

Figure 13 Parameter estimates $\hat{\sigma}_1$ and $\hat{\sigma}_2$ of L1-controller without aid of feedforward.

E. Comments on simulation results

Both the L1-controller and the state-feedback controller on its own benefits from the addition of feedforward compensations from the reference signal. Angle of attack and sideslip, in top left subplots, follow demands with smaller deviations when feedback controllers are aided by feedforward signals. This is accomplished with control surface deflections in roll δ_a , pitch δ_e and yaw δ_r that are similar in magnitude for the two simulations.

Nominal settings with feedforward from reference Fig. 6 & Fig. 7:

Results are good for both controller designs in keeping α and β close to demanded values throughout the maneuver sequence. Peak-to-peak values for β error are less than 1° throughout the simulation. Both controllers follow roll rate demands properly and have similar control signal amplitudes (actuator demands).

No feedforward applied Fig. 8 & Fig. 9:

Both controllers struggle to follow reference-values, large deviations occur. This severe deviation from linear behavior in the plant dynamics is too large for both types of controllers (state feedback and L1-control) to compensate for.

Parameters perturbed Fig. 10 & Fig. 11:

Both systems are stable and the performance is acceptable with the L1-controller active. The feedforward design shows good performance even though large deviations from the nominal assumptions are at hand, especially together with the L1-controller. Other realizations of parameter values show similar results.

In the L1-controller an estimation of the input-load disturbance $\hat{\sigma}$ is performed¹¹. These matched and unmatched parameter estimates $\hat{\sigma}_1$ and $\hat{\sigma}_2$ are shown in Fig. 12 and Fig. 13 for simulations corresponding to Fig. 6 and Fig. 8.

Results are shown for the pitch channel in which there are two signals, one solid for the matched load disturbance estimate and one dashed for the unmatched load disturbance estimate. As expected the magnitude of the parameter estimates are larger when feedforward signals are not active since then the adaptive controller will have to handle a larger amount of deviation from a linear response.

V. Summary and conclusions

The method proposed here design a structure suitable for use of adaptive control for flying vehicles. A feedforward design that is applicable to aerial vehicles was designed and tested. It uses the nonlinear state equations and also uses the same reference system dynamics as the adaptive controllers. The design created makes it possible to apply nonlinear feedforward compensations so that linear dynamics nominally will be left to handle for the controllers. Reference systems and feedforward signals have been tested for both fighter aircraft and missiles together with linear state feedback and L1 adaptive control methodology³. This design has the following benefits:

1. Fundamentals of the flight dynamics are used to create reference systems that scale to the present conditions. This takes less effort than use of for example gain-scheduling and several controllers for combinations of airspeed and altitude.

2. Feedforward and feedback that make the dynamics act like the linear reference system puts an adaptive controller in a better position of reducing truly unknown factors such as disturbances and deviations from nominal assumptions.

One of the key concerns when dealing with feedforward is that nominal values of parameters need to be used. This concern comes from the circumstance that *variance* in parameters can be large. However, even though large variation around nominal values in parameters can be at hand, it is useful to incorporate the *mean* value of a parameter into the system, in this design it is done by feedforward and variance effects will be dealt with by feedback and possibly by an adaptive controller.

An adaptive controller of L1-adaptive type will quickly try to identify the cause of deviations from the desired system response. If the nominal characteristic of the system is incorporated into the controller by feedforward the adaptive estimates will have smaller values and a trade-off can be done. An adaptive controller of L1-type will estimate deviations and compensate for them by feedback within the bandwidth of the control channel¹⁴. The feedforward created here has been tuned to act up to a high frequency and feedback controllers will then take care of smaller deviations due to uncertainties and disturbances. The design elements created here will add possibilities to the design of choosing feedforward and feedback compensation, compared to the most common industrial method, linear quadratic state feedback gains combined with gain-scheduling.

Acknowledgments

This feasibility study of adaptive control for aircraft and missiles is financed by Vinnova, a Swedish governmental agency for innovation, together with SAAB AB, a Swedish defense and security company. The project is part of “NFFP5”, the fifth in a series of Swedish governmental, academia and industry flight research co-operations. The authors are members of the LCCC Linnaeus Center and the eLLIIT Excellence Center at Lund University.

References

- ¹Åström K. J. and Wittenmark B., *Adaptive control*, Dover Publications, Inc., Mineola, 2008.
- ²Dydek Z. T., Annaswamy A. M. and Lavretsky E., “Adaptive Control and the NASA X-15-3 Flight Revisited”, IEEE Control Systems Magazine, June 2010, pp.32-48
- ³Hovakimyan N. and C. Cao, *L1 adaptive control theory*, SIAM, Philadelphia, 2010
- ⁴Fliess M., Lévine J., Martin P. and Rouchon P., “A Lie-Bäcklund approach to equivalence and flatness of nonlinear systems”, IEEE Transactions on Aut. Control, vol. 44, no 5, May 1999, p.922-937.
- ⁵Hagenmeyer V. and Delaleau E., “Exact feedforward linearization based on differential flatness”, Int. J. Control, Vol. 76, 2003, pp.537-556.
- ⁶Government publication, “Application of multivariable control theory to aircraft control laws, Multivariable control design guidelines”, Honeywell Inc., MN, 1996.
- ⁷Härkegård O. and Glad T., “Vector backstepping for flight control”, in *Proc. AIAA GNC Conference*, Hilton Head, SC, Aug. 2007, AIAA-2007-6421.
- ⁸Etkin B., *Dynamics of atmospheric flight*, John Wiley & Sons, Inc., New York, 1972.
- ⁹Zarchan P., *Tactical and strategic missile guidance*, AIAA Inc., Reston, 2002.
- ¹⁰Pettersson A., Åström K. J., Robertsson A. and Johansson R., “Augmenting L1 adaptive control of piecewise constant type to a fighter aircraft”, in *Proc. AIAA GNC Conference*, Minneapolis, MN, Aug. 2012, AIAA-2012-4757.
- ¹¹Pettersson A., Åström K. J., Robertsson A. and Johansson R., “Analysis of Linear L1 Adaptive Control Architectures for Aerospace Applications”, in *Proc. IEEE Conference on Decision and Control (CDC2012)*, Maui, HI, Dec 2012.

¹²Khalil H.K., *Nonlinear Systems*, Prentice-Hall, 3rd ed., New Jersey, 2002.

¹³Krstić M., Kanellakopoulos I. and Kokotović P., *Nonlinear and Adaptive Control Design*, , John Wiley & Sons, New York, 1995.

¹⁴Stein G., Respect the unstable, *IEEE Control Systems Magazine*, vol. 23, no. 4, Aug. 2003, pp.12-25.

¹⁵Stevens B. L. and Lewis F. L., *Aircraft Control and Simulation*, John Wiley & Sons, Inc, New York, 2003.