



LUND UNIVERSITY

On H-infinity model reduction of MIMO systems

Sootla, Aivar; Kotsalis, Georgios; Rantzer, Anders

2008

[Link to publication](#)

Citation for published version (APA):

Sootla, A., Kotsalis, G., & Rantzer, A. (2008). *On H-infinity model reduction of MIMO systems*. Paper presented at Reglermöte 2008.

Total number of authors:

3

General rights

Unless other specific re-use rights are stated the following general rights apply:

Copyright and moral rights for the publications made accessible in the public portal are retained by the authors and/or other copyright owners and it is a condition of accessing publications that users recognise and abide by the legal requirements associated with these rights.

- Users may download and print one copy of any publication from the public portal for the purpose of private study or research.
- You may not further distribute the material or use it for any profit-making activity or commercial gain
- You may freely distribute the URL identifying the publication in the public portal

Read more about Creative commons licenses: <https://creativecommons.org/licenses/>

Take down policy

If you believe that this document breaches copyright please contact us providing details, and we will remove access to the work immediately and investigate your claim.

LUND UNIVERSITY

PO Box 117
221 00 Lund
+46 46-222 00 00

On H-infinity model reduction of MIMO systems.

Aivar Sootla, Anders Rantzer, Georgios Kotsalis

Abstract—In this paper we study multi-input-multi-output (MIMO) extensions of a recently proposed model reduction algorithm for single-input-multi-output (SIMO) linear time-invariant (LTI) systems. We discuss three versions, including a trivial modification of the SIMO method. Reduced models are found by solving a convex problem with Linear Matrix Inequality (LMI) constraints given a state space model or a frequency-sampled version. We construct examples that illustrate the properties of methods, compare algorithms and apply them on an industrial bench-mark.

I. INTRODUCTION.

Model reduction problems has received considerable attention in past and several approaches were developed. Balanced Truncation (BT) and Hankel Optimal Model Reduction (HOMR) are recognized in the control literature, (see, for example, [6], [2]), due to well-developed theory and a priori error bounds. Both methods rely on solution of Lyapounov equations whose size is determined by the order of the original models. The approximation error of G by HMOR is bounded as:

$$\sigma_n(G) \leq \|G - \hat{G}_h\|_\infty \leq \sum_{n+1}^N \sigma_i(G),$$

where \hat{G}_h is a reduced system, obtain by HOMR, N, n are orders of original and reduced systems, correspondingly and $\sigma_1(G) \geq \dots \geq \sigma_N(G)$ are Hankel singular values of G (see, for example, [6], [2]). However, the approximation gap depends on the order of the original system:

$$\frac{\|G - \hat{G}_h\|_\infty}{\sigma_n(G)} \leq N - n + 1$$

The approximation gap of BT depends on the order of reduced system as well. Using HMOR and BT on systems with very big or infinite N produces two problems: computational cost of solving Lyapounov equations depended on N and generally unknown approximation gap.

In [5],[8] a new approach to model reduction was developed. A relaxation was proposed that allows formulation of model reduction as a convex optimization problem. The method can be applied to exact models or frequency sampled models. Frequency sampling makes it possible to use much less information about original model. In [8], a guaranteed sub-optimality bound is obtained. The approximation gap of the method does not depend on the original system order.

A. Sootla and A.Rantzer are with Department of Automatic Control, Lund University, Lund, Sweden {aivar, rantzer}@control.lth.se
G. Kotsalis is with Department of Electrical and Computer Engineering, Georgia Institute of Technology, Atlanta, GA, USA georgios.kotsalis@ece.gatech.edu

In this paper we discuss MIMO extensions of the SIMO model reduction method in [8]. We propose a general heuristic algorithm, with two special cases. One special case is a straightforward extension of the SIMO method with the same suboptimality bound. However, this algorithm is rather restrictive for MIMO systems. The second special case is more general.

The paper is organized as follows. In section II we describe reduction algorithms. In III we discuss some properties of the reduced model. Section IV is dedicated to implementation of algorithms. We construct examples in II-B,IV-C illustrating advantages and disadvantages of the methods and we compare MIMO extensions in IV-D. In IV-E we apply our reduction method on Shell Oil Fractionator bench-mark.

Notation.

We will use H_∞ and H_∞^- to denote spaces of stable and anti-stable scalar $m \times m$ transfer function matrices (TFMs), where $m \geq 2$. The set RH_∞ is a subset of H_∞ of all proper rational TFMs, and R_rH_∞ — a subset of RH_∞ of TFMs with McMillan degree equal to r . If $G \in H_\infty$ the operation \sim denotes a conjugate in H_∞ space: $G^\sim(z) = G^T(1/z)$, and $h^\nabla(z) = z^k h^\sim(z)$, where $h(z) = \sum_{i=0}^k h_i z^i$. G_w is a frequency response $G(e^{j\omega})$ to $\omega \in \mathbb{R}$

Since we will refer to both Hankel singular values and singular values (singular value functions) of matrices (of TFMs) we will use notation $\sigma_1(G) \geq \dots \geq \sigma_N(G)$, only when we referring to Hankel singular values. $\bar{\sigma}(G_w)$ denotes the maximal singular value of the matrix G_w .

The norm in H_∞ is a L_∞ norm of maximal singular value function of G on the unit circle $\|G\|_\infty = \sup_w \bar{\sigma}(G_w)$. The Hankel norm of a TFM is denoted $\|\cdot\|_H$ (see for example [6]). In this paper we will use one more norm of elements in $\mathbb{R}^{n \times m}$. Assume first that $x \in \mathbb{R}^{m \times 1}$, $A > 0 \in \mathbb{R}^{m \times m}$, then we can define a norm $\|x\|_A^2 = x^T A x$. If $x \in \mathbb{R}^{m \times m}$, we can denote norm as $\|x\|_A^2 = \lambda(x^T A x)$.

II. MODEL REDUCTION OF MIMO SYSTEMS.

The basic problem we want to solve can be formulated as:

$$G_n = \arg \min_{\hat{G} \in R_n H_\infty} \|G - \hat{G}\|_H \quad (1)$$

and $G \in H_\infty$. This problem is not convex and often suboptimal methods are used. Here we will relax (1) and obtain a convex optimization problem.

A. General MIMO case algorithm.

Assume $\hat{G} = b a_1^{-1}$, where $a_1 = \sum_0^r (a_1)_i z^i$ is a matrix polynomial of degree r and $(a_1)_r \neq 0$, with $\det(a_1)$ a Schur

polynomial ($\det(a_1) > 0 \forall z : |z| \geq 1$) and $b = \sum_{i=0}^r (b_1)_i z^i$ is a matrix polynomial with $(a_1)_i, (b_1)_i \in \mathbb{R}^{m \times m} \forall i$. We rewrite the problem in new definitions:

$$\min_{b, a_1} \|G - ba_1^{-1}\|_\infty, \quad (2)$$

We propose the relaxation to make problem a convex one, similar relaxation was made in [5]. Instead of (2) minimize the following over a_1, a_2, b, c :

$$\|G - ba_1^{-1} - ca_2^{-\nabla}\|_\infty, \quad (3)$$

where $\Delta_- = ca_2^{-\nabla} \in R_{rm}H_\infty^-$ is an anti-stable term, c, a_2 are matrix polynomials of order less than $r-1$ and equal to r correspondingly. $\det(a_2)$ is a Schur polynomial and a_1, a_2 are related in the following way

$$A = a_1 a_1^{-\sim} = a_2^{-\sim} a_2 \quad (4)$$

The relaxation needs motivation. In fact, $\min \|G - G_-\|_\infty = \|G\|_H$, where minimization is performed over all possible anti-stable terms G_- . Moreover if we release Δ_- term we will get HOMR:

$$\min_{\Delta_-, b, a_1} \|G - ba_1^{-1} - \Delta_-\|_\infty = \min_{b, a_1} \|G - ba_1^{-1}\|_H \quad (5)$$

Denote:

$$B + jC = z^{-r}(ba_2^{-\nabla} + ca_1) \quad (6)$$

The polynomials A, B, C have certain properties to fulfil. $A(z) > 0$, if $z = e^{j\omega} \forall \omega$, making $\det(a_1)$ a Schur polynomial (the reduced system ba_1^{-1} stable). We will fix the term $(A)_r$ to identity, to normalize calculations. Conditions $(A)_i = (A)_{-i} = (A)_i^T$, $(B)_i = (B)_{-i}$, $(C)_i = (C)_{-i}$ imply that A, B, C are trigonometric polynomials and provide a convenient parametrization. The condition $A_0 > 0$ implies that the spectral factorization problems (4) can be solved¹.

$$\begin{aligned} A &= I(z^r + z^{-r}) + \sum_{i=0}^{r-1} (A)_i (z^i + z^{-i}) \\ B &= \sum_{i=0}^r (B)_i (z^{r-i} + z^{-r+i}) \\ C &= \frac{1}{j} \sum_{i=0}^{r-1} (C)_i (z^{r-i} - z^{-r+i}) \end{aligned}$$

There exist one to one correspondence between a_1, a_2, b, c and A, B, C . It is obvious that knowing a_1, a_2, b, c we can always find A, B, C . On the other hand with known A, B and C , (4) gives co-prime $a_1, a_2^{-\sim}$, so (6) can be solved uniquely for b and c . Now we have the problem:

$$\min_{A, B, C} \gamma \text{ subject to } \|G - (B + jC)A^{-1}\|_\infty < \gamma \quad (7)$$

If $A = \tilde{A}I$, where \tilde{A} is a scalar polynomial, minimization problem (7) is equivalent to a convex optimization procedure:

$$\begin{aligned} &\min_{A, B, C} \gamma \text{ subject to} \\ &\left(\begin{array}{cc} \gamma \tilde{A}I & G\tilde{A} - B - jC \\ * & \gamma \tilde{A} \end{array} \right) > 0 \quad \forall \omega, \end{aligned}$$

¹More about this condition in section III-A

where asterisk stands for hermitian transpose of upper right corner. In MIMO-case we want to get a similar LMI condition, but the minimization problem has to make sense as well. Rewrite the constraint in (7) for every frequency ω as: $\bar{\sigma}(G_w - (B_w + jC_w)A_w^{-1}) < \gamma$, what is equivalent to:

$$\|G_w - (B_w + jC_w)A_w^{-1}\|_I < \|\gamma\|_I, \quad \forall \omega$$

We propose following relaxation: instead of identity matrix use A_w :

$$\|G_w - (B_w + jC_w)A_w^{-1}\|_{A_w} < \|\gamma\|_{A_w} \quad \forall \omega \quad (8)$$

One can show that constraint (8) can be rewritten in the form of LMI:

$$\left(\begin{array}{cc} \gamma A_w & G_w A_w - B_w - jC_w \\ * & \gamma A_w \end{array} \right) > 0, \quad \forall \omega, \quad (9)$$

Finally we obtain a convex program:

$$\min \gamma \text{ subject to (9)} \quad (10)$$

This is a generalized eigenvalue problem, that can be solved for sample data model. It is also possible to use exact model (see, section II-E).

We will use program (10) to find denominator a_1 only, where a_1 is a spectral factor of A as in (4). The numerator will be found from another convex program:

$$\min_{b \in \mathcal{C}} \delta \text{ where } \mathcal{C} = \{b \mid \|G - ba_1^{-1}\| < \delta\} \quad (11)$$

The described method has a lot of advantages, but there is major drawback. LMI condition (9) doesn't imply that $\|G - BA^{-1}\|_\infty$ is small. To show that, we will consider an example.

B. Example 1. Existence of error bound.

Assume we want to reduce:

$$G = \begin{bmatrix} 0 & z^{-n} \\ 0 & 0 \end{bmatrix}$$

We can achieve arbitrary small γ solving (10), because method doesn't produce nor upper bound, nor lower bound for $\sigma(A(e^{j\omega}))$. However, computing (11) gives us approximation error $\|G - ba_1^{-1}\|_\infty \leq 1.02$. and we still get a better approximation than HMOR. All the Hankel singular values of G are equal to 1. So the lower bound is $\sigma_6(G) = 1$. That means that the best approximation is in fact a stable TFM with gain very close to zero. HMOR produces a static gain TFM, with approximation error $\sqrt{2}$:

$$\hat{G} = \begin{bmatrix} 0 & 1 \\ 0 & 0 \end{bmatrix}.$$

Although described algorithm fails to provide error bound $\|G - BA^{-1}\|_\infty < K\gamma$, for any constant K , we can achieve it if we enforce extra constraints on A .

C. Restriction of denominator to diagonal matrix.

Assume, that our polynomial A has diagonal structure, i.e. $A = \tilde{A}I$, where $\tilde{A}(z) > 0 \forall |z| = 1$ is a scalar polynomial. Thus we obtain the similar program:

$$\min \gamma \text{ subject to} \quad (12)$$

$$\begin{pmatrix} \gamma \tilde{A}_w I & G_w \tilde{A}_w - B_w - jC_w \\ * & \gamma \tilde{A}_w I \end{pmatrix} > 0, \forall \omega \quad (13)$$

One can show that constraint (13) enforced for all ω implies $\|G - BA^{-1}\|_\infty < \gamma$. In this case the problem is a trivial extension of SIMO method [8], what allows us to formulate similar result:

Theorem 2.1: If γ is obtained from minimization procedure (12,13), \hat{G}_{rm}, δ are obtained from minimization procedure (11) and $\sigma_{rm+1}(G)$ is a $rm + 1$ -th Hankel singular value, then:

- 1) $\gamma \geq \sigma_{rm+1}(G)$
- 2) $\|G - \hat{G}_{rm}\|_\infty < \delta \leq (rm + 1)\gamma$

D. Relaxing the restriction on denominator.

We would like to have a method with a guaranteed suboptimal bound as in previous section, but with extra freedom on A . One way to deal with this problem is relaxing (12,13) as follows:

$$\min \gamma \text{ subject to} \quad (14)$$

$$\begin{pmatrix} \gamma \tilde{A}_w I & GA_w - B_w - jC_w \\ * & \gamma \tilde{A}_w I \end{pmatrix} > 0, \forall \omega \quad (15)$$

where A, B, C matrix polynomials from section II-A, $\tilde{A}(z) > 0 \forall |z| = 1$ is a scalar function and $\tilde{A}_w I < A_w \forall \omega$

Lemma 2.2: If matrix polynomials A, B, C and scalar function \tilde{A} satisfy (15) and constraints described above for some G, γ , then $\|G - (B + jC)A^{-1}\|_\infty < \gamma$,

Proof: Rewrite LMI condition (15) using Schur complement:

$$\begin{aligned} \gamma^2 \tilde{A}_w &> (G_w - (B_w + jC_w)A_w^{-1}) \cdot \\ &\cdot A_w (G_w - (B_w + jC_w)A_w^{-1})' \\ \gamma \tilde{A}^{-1} &> \overline{\sigma}(G - (B + jC)A^{-1})A^{1/2} \\ \gamma \left(\tilde{A} / \underline{\sigma}(A) \right)^{1/2} &> \overline{\sigma}(G - (B + jC)A^{-1}) \end{aligned}$$

Since $\tilde{A} / \underline{\sigma}(A) < 1$, result follows after taking supremum over all ω of the right-hand side of inequality. ■

Consequence 2.3: Theorem 2.1 is valid for described algorithm.

E. Enforcing LMI conditions for all frequencies

LMI (9) and $A(e^{j\omega}) > 0$ can be enforced for all ω at once using KYP lemma. The simpler condition $A > 0$ we examine first. Notice that, $A(z)$ can be written as:

$$A(z) = A_0 + \sum_{i=1}^r (A_i z^i + A'_i z^{-i}) = V_z \tilde{A}_m V_z \quad (16)$$

where

$$A_m = \begin{pmatrix} A_0 & A_1 & \dots & A_r \\ A'_1 & 0 & \dots & 0 \\ \vdots & \vdots & \ddots & \vdots \\ A'_r & 0 & \dots & 0 \end{pmatrix} \quad (17)$$

$$V_z \tilde{=} = \begin{pmatrix} I & Iz^{-1} & \dots & Iz^{-r} \end{pmatrix} \quad (18)$$

Then the condition $A(e^{j\omega}) > 0$ can be enforced for all w using KYP lemma described in [10].

Rewrite matrix (9) as:

$$\begin{aligned} (9) &= \begin{pmatrix} 0 & GA \\ AG^\sim & 0 \end{pmatrix} + \begin{pmatrix} \gamma A & B + jC \\ (B + jC)^\sim & A \end{pmatrix} \\ \begin{pmatrix} 0 & GA \\ AG^\sim & 0 \end{pmatrix} &= \begin{pmatrix} G & 0 \\ 0 & I \end{pmatrix} \begin{pmatrix} 0 & A \\ A & 0 \end{pmatrix} \begin{pmatrix} G^\sim & 0 \\ 0 & I \end{pmatrix} \end{aligned}$$

Polynomials B, C can be represented the same way as A polynomial in (16). Then:

$$(9) = V_w \tilde{=} M_w V_w, \quad (19)$$

where

$$\begin{aligned} V_w &= \begin{pmatrix} V_z & 0 \\ 0 & V_z \\ V_z & 0 \\ 0 & V_z \end{pmatrix} \begin{pmatrix} G^\sim & 0 \\ 0 & I \\ I & 0 \\ 0 & I \end{pmatrix} \\ M_w &= \begin{pmatrix} 0 & Am & 0 & 0 \\ Am & 0 & 0 & 0 \\ 0 & 0 & \gamma Am & (Bm + jCm) \\ 0 & 0 & (Bm + jCm)^\sim & \gamma Am \end{pmatrix} \end{aligned}$$

As matrix V_w doesn't depend on any unknown parameter we can use the same formulation of KYP lemma. Notice that the dimension of second LMI will equal to $4rm$, so the number of parameters will rise too much and so will the computational cost. In practice it is more convenient to use only (16) and enforce LMI (9) on frequency grid.

III. PROPERTIES OF REDUCED MODELS.

A. Spectral factorization.

Assume we have $A(z)$ — matrix polynomial of order $2r$: $A(z) = \sum_{i=-r}^r A_i z^i$, where $A_i = A'_{-i}$. We can

write $A(z) = Z_{pr}(z) + Z'_{pr}(z)$, where $Z_{pr} = \sum_{i=0}^r A_i z^{-i}$.

Transfer function Z_{pr} is proper, with state-space realization $\{A_Z, B_Z, C_Z, D_Z\}$, and invertible D_Z matrix. Last condition is necessary for existence of solution to spectral factorization problem² (it also means, that $A_0 > 0$).

Let's examine the solution from [1]. First we need to solve the Riccati equation:

$$\begin{aligned} P_{k+1} &= A_Z P_k A'_Z - (A_Z P_k C'_Z - B_Z) \cdot \\ &\cdot (D_Z + D'_Z - C_Z P_k C'_Z)^\dagger (A_Z P_k C'_Z - B_Z)' \end{aligned} \quad (20)$$

where A^\dagger denotes Moore-Penrose pseudo-inverse. It is shown that the limit $\lim_{k \rightarrow \infty} P_k = P$ exists, the equation always has solution $P \geq 0$ and the matrix $D_Z + D'_Z - C_Z P C'_Z \geq 0$.

²see, for example, [1], [11]

In fact we would like the term $D_Z + D'_Z - C_Z PC'_Z$ to be positive definite, not only positive semi-definite. Notice that $\lim_{\varepsilon \rightarrow 0} (D_Z + D'_Z - C_Z PC'_Z + \varepsilon I)^{-1} \neq (D_Z + D'_Z - C_Z PC'_Z)^\dagger$, but the solution P_ε of:

$$P_{k+1} = A_Z P_k A'_Z - (A_Z P_k C'_Z - B_Z) \cdot (D_Z + D'_Z - C_Z P_k C'_Z + \varepsilon I)^{-1} (A_Z P_k C'_Z - B_Z)' \quad (21)$$

is convergent to the solution P of (20), i.e. $\lim_{\varepsilon \rightarrow 0} P_\varepsilon = P$, the matrix $D_Z + D'_Z - C_Z PC'_Z + \varepsilon I$ is positive-definite and as follows invertible.

The state-space description of stable factor is given by $a_1 \cdot z^{-r} = \{A_Z, B_{a_1}, C_Z, D_{a_1}\}$, where $D_{a_1} = (D_Z + D'_Z - C_Z PC'_Z + \varepsilon I)^{1/2}$, $B_{a_1} = (B_Z - A_Z PC'_Z) D_{a_1}^{-1}$, and P is a solution of (21) which converges to the actual solution of (20). Since we introduced the ε term in Riccati equation we will always get invertible D_{a_1} matrix. In practice we would rather solve the following equation:

$$-\varepsilon_2 I = A_Z P A'_Z - P - (A_Z PC'_Z - B) \cdot (D_Z + D'_Z - C_Z PC'_Z + \varepsilon_1 I)^{-1} (A_Z PC'_Z - B)' \quad (22)$$

The term $\varepsilon_2 I$ is added to get more robust numerically solution. This way we don't have to solve the equation (21) recursively, so the relaxation which should make solution less accurate, does the contrary.

B. McMillan degree of reduced system.

In this section we will prove that under our assumptions $\hat{G} = b(z)a_1^{-1}(z) \in R_{rm}H_\infty$, where $a_1(z), b(z)$ are matrix polynomials of degree r . All the results and definitions can be found in [4].

If $\hat{G} = ba_1^{-1}$, then a_1, b is called *matrix-fraction description*. In our problem \hat{G} is square matrix, so we can define *poles* (MFD) of $\hat{G}(z)$ as zeros of $\det(a_1(z))$. An MFD $\hat{G} = ba_1^{-1}$ will be said to be irreducible if $b(z)$ and $a_1(z)$ are right coprime.

Definition 3.1: In general we can always write $a_1(z) = (D_{hc}S(z) + L(z))$, where $S(z) = \text{diag}\{s^{k_i}, i = \overline{1, m}\}$, D_{hc} — the highest-column-degree coefficient matrix of $a_1(z)$ is a matrix whose i th column comprises the coefficients s^{k_i} in the i th column of $a_1(z)$.

We will need one known lemma:

Lemma 3.1 ([4]): $\deg(\det(a_1(z))) = rm$ if and only if the highest-column-degree coefficient matrix D_{hc} of $a_1(z)$ is invertible.

The main result of this section is that we always get a realization of degree not more than rm :

Lemma 3.2: If b, a_1 a MFD, where $A = a_1 a_1^{-1}$ is obtained from program:

$$\min \gamma \text{ subject to (9),}$$

then the McMillan degree of the system $\hat{G} = ba_1$ is less or equal to rm .

Proof: First assume that MFD b, a_1 is irreducible. If it the case than the $\deg(\hat{G}) = rm$. If not we can always obtain irreducible MFD and the order $\deg(\hat{G})$ would be equal to the order of reduced denominator \tilde{a}_1 .

Notice that we obtain a_1 from spectral factorization problem (described in section III-A). Since D_{a_1} matrix of a_1 is invertible, then in every column there exist at least one non-zero coefficient of highest degree. Then the highest-column-degree coefficient matrix D_{hc} is equal to D_{a_1} and invertible. After applying lemma 3.1 the results follows. ■

IV. IMPLEMENTATION AND EXAMPLES.

A. Algorithm.

Basically we have discussed one algorithm with three different cases:

$$\min \gamma \text{ subject to} \quad (23)$$

$$\begin{pmatrix} \gamma A_1 & (GA_2 - B - jC) \\ (GA_2 - B - jC)^\sim & \gamma A_2 \end{pmatrix} > 0 \quad (24)$$

- 1) **Matrix case.** $A_1 = A_2 = A$, where A is matrix polynomial (section II-A)
- 2) **Scalar case.** $A_1 = A_2 = \tilde{A}I$, where is a scalar polynomial (section II-C).
- 3) **Mixed case.** $0 < A_1 \leq A_2$ on unit circle, where A_1 is a scalar function multiplied with identity matrix and A_2 is a matrix polynomial (section II-D).

The algorithm is described as follows:

- (a) First solve (23,24) for given γ . Solution will provide us with A_1, A_2, B, C matrices.
- (b) Solve the factorization problem for A_1 . Then minimize over numerator b as in (11)
- (c) Repeat (a-b) with smaller γ , if required.
- (d) When the suitable value δ is achieved find the minimal state-space realization of MFD.

The methods above were implemented using LMI solver SeDuMi [12] with YALMIP [7].

B. Method of computing minimal state-space realization.

We assume that our MFD is irreducible. It is a reasonable assumption, since reducibility implies zero-pole cancellation and as follows lower degree \hat{G} . It is obvious that for every approximation of \hat{G} we can find a better approximation with higher degree McMillan degree then the original one. Nevertheless there is no strict prof that b, a_1 are always right coprime.

This method is actually considered for strictly proper TFMs, but it is not so difficult to obtain a strictly proper from a proper TFM. Assume ba_1^{-1} is a strictly proper TFM. Notice that in our case $a_1(z) = D_{hc}z^r + D_{lc}\Psi(z)$, where $\Psi'(z) = \text{block diag}\{[z^{r-1}, \dots, 1], \dots, [z^{r-1}, \dots, 1]\}$. Then $b = N_{lc}\Psi(z)$. Denote:

$$A_c^0 = \text{blockdiag} \left\{ \begin{pmatrix} 0_{r-1,1} & 0 \\ I_{r-1} & 0_{1,r-1} \end{pmatrix}_i, i = 1, \dots, m \right\}$$

$$[B_c^0]' = \text{blockdiag} \left\{ (1 \ 0_{r-1,1})_i, i = 1, \dots, m \right\}$$

$$C_c^0 = I_n, \quad n = \deg \det a_1 = rm$$

Then the state-space realization of original TFM ba_1^{-1} is $\{A_c, B_c, C_c\}$:

$$A_c = A_c^0 - B_c^0 D_{hc}^{-1} D_{lc} \quad B_c = B_c^0 D_{hc}^{-1} \quad C_c = N_{lc} \quad (25)$$

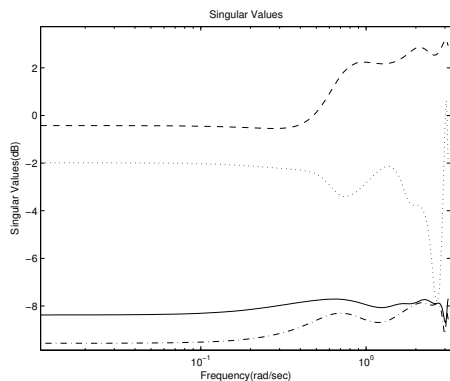

Fig. 1. Plot of maximal singular value function of the error of matrix case (solid), scalar case algorithm (dashed) mixed case (dash-dot) and HMOR(dot) algorithms.

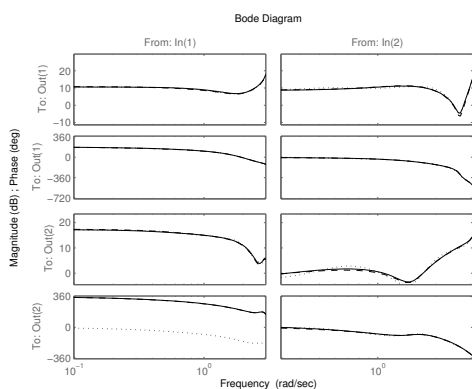

Fig. 2. Bode plot of original (dots) and reduced with matrix case (dashed) and mixed case (dash-dot) algorithms.

C. Example 2. Approximation of high order system.

The main advantage of our approach is that we use less information about original system than HMOR and BT. There is always a memory restriction on solving high-dimensional Lyapounov equations. Assume G is 2 by 2 TFM with order $N = 600$:

$$G = \left(5 + 5/z + 5/z^2 + \sum_{i=3}^{600} 0.01/z^i \right) I_2$$

We weren't able to apply HMOR and BT on this system. however, applying MIMO heuristics was successful. We applied matrix case and mixed case algorithms with 20 points in the grid and have got a 6-th order approximation with error $\delta < 2 \cdot 10^{-2}$ in both cases.

D. Example 3. Comparison of algorithms.

We would like to compare the performance of two special cases and general heuristic algorithm. Although there is no error bound in general case, example 1 provided us with hope, that reduced model can be close in H_∞ to original one. We would expect the natural extension to have worse performance then two other cases. Assume G is a random 2-input 2-output TFM with McMillan degree of 20. We will

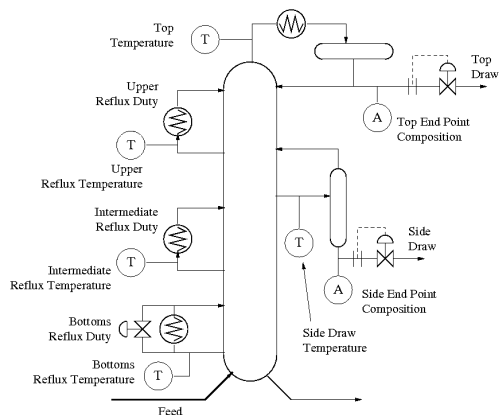

Fig. 3. The 'Shell' heavy oil fractionator.

TABLE I

NAMES, ROLES AND SYMBOLS OF INPUT AND OUTPUT VARIABLES.

Variable	Role	Symbol
Top Draw	Control Input	u_1
Side Draw	Control Input	u_2
Bottoms Reflux Duty	Control Input	u_3
Intermediate Reflux Duty	Measured Disturbance	d_m
Upper Reflux Duty	Unmeasured Disturbance	d_u
Top End Point	Controlled and measured output	y_1, z_1
Side End Point	Controlled and measured output	y_2, z_2
Top Temperature	Measured output	y_3
Upper Reflux Temperature	Measured output	y_4
Side Draw Temperature	Measured output	y_5, z_3
Intermediate Reflux Temperature	Measured output	y_6, z_4
Bottoms Reflux Temperature	Controlled and measured output	y_7, z_5

reduce the model to 6 states using three cases and HMOR. The best approximation was found by mixed case algorithm (see, pic. 1), and both mixed case and matrix case have better approximation than HMOR almost for every frequency. Most interesting to compare, of course, mixed and matrix case algorithms. Although, we get a better error in mixed case, we get a better upper bound δ in matrix case algorithm. We can see on bode plot (pic. 2) of original model, mixed case and matrix case algorithms, that reduced models almost coincide with each other, but not with original model.

E. Shell Oil Fractionator.

The model is described in [9], but we will use a simplified version given in [3].

The inputs of the model are: Top Draw, Side Draw, Bottoms Reflux Duty, Intermediate Reflux Duty, Upper Reflux Duty. The Outputs are: Top End Point, Side end Point, Intermediate Reflux Duty, Bottoms Reflux Duty, Bottoms Reflux Temperature.

We will consider a transfer function from the inputs u_1, u_2, u_3, d_m, d_u to outputs z_1, z_2, z_3, z_4, z_5 . In the original model Intermediate Reflux duty, Upper Reflux Duty are considered disturbances and Intermediate Reflux Temperature, Side Draw Temperature are considered just a measured output. We added them just to make the problem more interesting.

Now we have a 5 input, 5 output model with delays. The model is nonlinear, but since all the delays are factors of sampling time we will get a linear discrete model with

TABLE II
SOME EXPERIMENTAL DATA ON UNIFORM GRID.

Order	20	20	25	25	25
Number of points	16	64	25	50	125
δ for matrix case	0.75	0.88	0.83	0.78	0.84
Actual error (matrix case)	11.13	0.88	5.01	1.022	0.84
δ for mixed case	0.56	1.18	0.45	0.62	0.75
Actual error (mixed case)	3.53	1.19	2.74	0.84	0.74

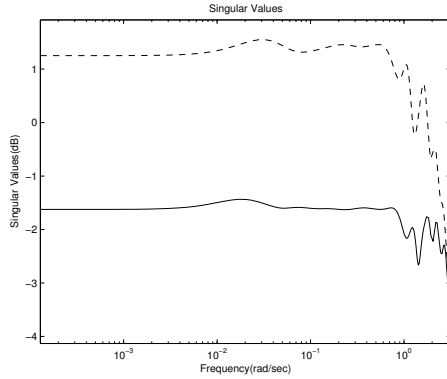

Fig. 4. The reduction error of matrix case (solid) and mixed case (dashed) algorithm with 20-th order approximations.

McMillan degree equal to 72. It worth mentioning that norm of original system is around 26.1 dB., we will assume that 5% approximation error of norm is allowed, i.e. we want the error to be not more than 1.

We will compare our algorithms for 20 and 25 order approximations. The essential problem is choosing the number of points in the grid (see table II). Too many points create extra complexity, too less, however, may not provide you with good approximation. On picture 4 we see maximal singular value functions of 20-th order approximation error, approximations are done with 64 points in the frequency grid. Here clearly matrix case algorithm shows better performance than mixed case. However, optimal A wasn't provided by lowest γ . It is clearly possible in matrix case algorithm, since there is no error bound on $\|G - BA^{-1}\|_{\infty} < K\gamma$, for any

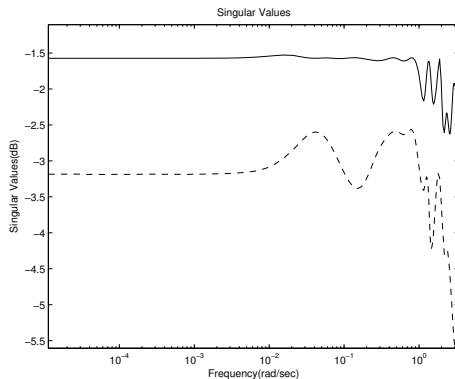

Fig. 5. The reduction error of matrix case (solid) and mixed case (dashed) algorithm with 25-th order approximations.

constant K .

On picture 5 we see the results of 25-th order approximations done with 125 points in the frequency grid. In this case mixed case algorithm has better H_{∞} approximation.

V. CONCLUSION.

In this paper we have discussed MIMO extensions of [8], where convex optimization is used to search for low order models. Unlike the SIMO case, there is no a priori error bound, but the MIMO extensions are very competitive in numerical experiments.

REFERENCES

- [1] B. Anderson, K. Hitz, and N. Diem. Recursive algorithm for spectral factorization. *Circuits and Systems, IEEE Transactions on*, 21(6):742–750, Nov 1974.
- [2] B.D.O. Anderson G. Obinata. *Model Reduction for Control System Design*. London,UK:Springer-Verlag, 2001.
- [3] J.M.Maciejowski. *Predictive Control with Constraints*. Prentice Hall, 2002.
- [4] T. Kailath. *Linear Systems*. Prentice-Hall: Englewood Cliffs, NJ, 1980.
- [5] Luca Daniel Kin Cheong Sou, Alexander Megretski. A quasi-convex optimization approach to parameterized model order reduction. In *IEEE/ACM Design Automation Conference*, June 2005.
- [6] J.C.Doyle K.Zhou. *Essentials of Robust Control*. Prentice-Hall,inc: Upper Saddle River, NJ, 1998.
- [7] J. Löfberg. Yalmip : A toolbox for modeling and optimization in MATLAB. In *Proceedings of the CACSD Conference*, Taipei, Taiwan, 2004.
- [8] A. Megretski. H-infinity model reduction with guaranteed suboptimality bound. *American Control Conference, 2006*, pages 448–453, 14-16 June 2006.
- [9] D.M. Prett and M. Morari. *The Shell Process Control Workshop. Process Control Research: Industrial and Academic Perspectives*. Butterworths, Boston, 1987.
- [10] Anders Rantzer. On the kalman-yakubovich-popov lemma. *Syst. Control Lett.*, 28(1):7–10, 1996.
- [11] A. H. Sayed and T. Kailath. A survey of spectral factorization methods. *Numerical linear algebra with applications*, 8(6-7):467–496, 2001.
- [12] J.F. Sturm. Using SeDuMi 1.02, a MATLAB toolbox for optimization over symmetric cones. *Optimization Methods and Software*, 11–12:625–653, 1999. Special issue on Interior Point Methods (CD supplement with software).