



# LUND UNIVERSITY

## Extrapolation and restrictive relative clauses

Manninen, Satu

2002

*Document Version:*

Publisher's PDF, also known as Version of record

[Link to publication](#)

*Citation for published version (APA):*

Manninen, S. (2002). *Extrapolation and restrictive relative clauses*. (pp. 1-17). (The Department of English in Lund: Working Papers in English Linguistics; Vol. 2). Department of English, Lund University.  
<https://www.sol.lu.se/engelska/forskning/working-papers/>

*Total number of authors:*

1

### General rights

Unless other specific re-use rights are stated the following general rights apply:

Copyright and moral rights for the publications made accessible in the public portal are retained by the authors and/or other copyright owners and it is a condition of accessing publications that users recognise and abide by the legal requirements associated with these rights.

- Users may download and print one copy of any publication from the public portal for the purpose of private study or research.
- You may not further distribute the material or use it for any profit-making activity or commercial gain
- You may freely distribute the URL identifying the publication in the public portal

Read more about Creative commons licenses: <https://creativecommons.org/licenses/>

### Take down policy

If you believe that this document breaches copyright please contact us providing details, and we will remove access to the work immediately and investigate your claim.

LUND UNIVERSITY

PO Box 117  
221 00 Lund  
+46 46-222 00 00

# Extraposition and Restrictive Relative Clauses

SATU MANNINEN

## 1 Introduction

In this paper, I investigate the construction found in English and a number of other languages in which the nominal “head” of a relative clause becomes separated from the rest of the relative clause by intervening material (the so-called relative clause extraposition construction).<sup>1</sup> The basic pattern is illustrated in (1):

- (1) a. [ A letter ] arrived yesterday [ which was addressed to Mary ]  
b. [ A handsome man ] walked into the room [ who looked like Ewan McGregor ]

Relative clauses are not the only constructions allowing extraposition. (2a-b) are examples of PP extraposition, (3a-b) of complement extraposition at clausal or sentence level:

- (2) a. [ A letter ] arrived yesterday [ from Antarctica ]  
b. I saw [an exciting film] last night [about the life of penguins]
- (3) a. John said last night [ that he was moving to Antarctica ]  
b. John told us last night at the party [ that he was moving to Antarctica ]

Extraposition phenomena are traditionally accounted for in terms of rightward movement. However, within more recent generative theories, including Chomsky’s (1995; 1999; 2000; 2001) minimalist frameworks and Kayne’s (1994) antisymmetric approach, rightward movement is banned on independent grounds. But at the same time, it is not clear if extraposition phenomena can be accounted for in terms of leftward movement either, because it is not immediately obvious what the moving elements are, what factors drive their movement, and what their derived positions are.

The aim of this paper is to present some work in progress on English restrictive relative clauses. In section 2, I introduce the different relative clause construction types and outline two different lines of analysis for restrictive relatives which are compatible with Kayne’s antisymmetry theory and the LCA. In section 3, I identify the problems created by extraposition phenomena for these systems. In section 4, I discuss some alternative accounts of restrictive relatives which avoid (at least some of) these problems, without being inconsistent with the LCA. The paper is best viewed as preliminary investigation into the different lines of analysis available, and the discussions are intended to serve as basis for future research.

In recent articles by e.g. Fox & Nissenbaum (1999) and Fox (2002), extraposition of relative clauses from DPs (as in (1) above) is analysed as involving covert quantifier raising (QR) of the nominal head followed by late merge of the relative clause. Crucially, these authors argue that QR applies to the right and, because it is a covert operation, the nominal head can be “pronounced in its base position,” while the relative clause is “pronounced at the right periphery where it is merged” (Fox 2002: 71). Although this line of reasoning opens up

---

<sup>1</sup> I use the term *nominal head* to refer to the whole nominal constituent that is the antecedent of the relative clause.

new possibilities for the analysis of relative clauses and extraposition phenomena, it is inconsistent with the antisymmetric approach and will therefore not be discussed here.

## 2 Two Analyses of Restrictive Relative Clauses

The standard typology of relative clauses distinguishes between headed and free relatives. In the former, the relative pronoun or complementiser appears together with the nominal head and the relative clause functions as a postmodifier of the head; see (4a-b). Headed relatives can sometimes lack relative pronouns or complementisers altogether; see (4c). In free relatives, the relative pronoun always appears alone. Free relatives also fulfill a range of grammatical functions, including subject, direct object, and adverbial; see (5a-c):

- (4) a. Here is [ the man [ who I love ] ]  
 b. Here is [ the man [ that I love ] ]  
 c. Here is [ the man [  $\emptyset$  I love ] ]
- (5) a. [ Whoever says so ] is an idiot  
 b. He eats [ whatever I serve him ]  
 c. You can leave [ whenever you like ]

Among headed relative clauses, a distinction is made between restrictive and non-restrictive relatives. Restrictive relatives, like those in (4) above, are necessary modifiers: they restrict the set of entities referred to by the nominal head and help pick out its referent. Non-restrictive relatives, like those in (6), give only additional information about the head whose reference is independently established; see e.g. Jackendoff (1977:171ff.), Kayne (1994:110ff.), Alexiadou et al (2000:30ff.), Bianchi (1999:Chapter V), and Platzack (2000):

- (6) a. That handsome man, who looks like Ewan McGregor, is my husband  
 b. John, who is going to move to Antarctica, is having a farewell party tomorrow

This paper focusses solely on the properties of restrictive relative clauses. Within pre-LCA (or, non-LCA) generative systems, restrictive relatives are standardly treated as N-bar or NP adjuncts; see e.g. Jackendoff (1977:169ff.), Alexiadou et al (2000), and Bianchi (1999:33ff.). In the case of left-adjunction, the relative clauses precede the nominal heads while in the case of right-adjunction, they follow them. Turkish and Hindi are examples of languages where relative clauses often precede their nominal heads, while in English, Swedish, and most other Germanic languages, they follow them.

The pre-LCA generative systems standardly assign different analyses for Wh- and that-relatives. In Wh-relatives, such as (7a), the relative pronoun *who* is a kind of operator binding a trace, and the  $C^0$  position is empty. In that-relatives, such as (7b), the Spec,CP contains a null operator and the relative complementiser *that* appears in  $C^0$  - see Chomsky (1977), Chomsky & Lasnik (1995:70ff.), and Alexiadou et al (2000) for more discussion:

- (7) a. [DP the [NP [NP man ] [CP  $who_i$   $C^0$  [  $t_i$  looks like Ewan McGregor ] ] ] ]  
 b. [DP the [NP [NP announcement ] [CP  $Op_i$  that [ John made  $t_i$  ] ] ] ]

But structures such as (7a-b) are ruled out by Kayne's (1994) antisymmetry theory and the LCA. This is because within the antisymmetric approach, asymmetric c-command is linked to linear precedence: if an element X asymmetrically c-commands another element Y, then X

precedes Y in linear ordering. In (7a-b), however, the right-adjoined relative clauses asymmetrically c-command the nominal heads *man* and *announcement* (i.e. they c-command these heads, but the heads cannot c-command them): given that asymmetric c-command directly corresponds to linear precedence, we would expect the relative clauses to precede rather than follow the heads in linear order.

Instead of treating relative clauses as adjuncts, some grammarians, including Platzack (2000), have proposed that they are complements and therefore sisters to a lexical  $N^0$  head. Even within this line of reasoning, Wh- and that-relatives are often assigned different structures:

- (8) a.  $[_{DP} \text{ the } [_{NP} [_{N^0} \text{ man } ] [_{CP} \text{ who}_i \text{ C}^0 [ t_i \text{ looks like Ewan McGregor } ] ] ] ] ] ]$   
 b.  $[_{DP} \text{ the } [_{NP} [_{N^0} \text{ announcement } ] [_{CP} \text{ Op}_i \text{ that } [ \text{ John made } t_i ] ] ] ] ] ]$

Although the idea of relative clauses as sisters to lexical  $N^0$ s is compatible with the antisymmetric approach, Kayne (1994: 87) rejects it and proposes instead that relative clauses are selected by functional  $D^0$ s as their complements. So instead of (8), we are dealing with the situation illustrated in (9):<sup>2</sup>

- (9)  $[_{DP} D^0 \text{ CP } ]$

Following ideas put forward by Schachter (1973), Vergnaud (1974) and others, Kayne (1994: 87f.) further argues that the nominal head of the relative clause is created internally, by raising the appropriate nominal category from inside the relative clause to its Spec,CP position. In Wh-relatives, the raising element is a DP while in that-relatives, it could be either a DP (e.g. Bianchi 1999) or an NP (e.g. Kayne 1994).<sup>3</sup> (10a-c) illustrate how in Wh-relatives, the relative pronoun *which* heads a relative DP and selects the NP *announcement* as its complement. Inside the relative DP, the NP raises to Spec,DP and inside the CP, the relative DP raises to Spec,CP, producing the correct hierarchical structure and linear order. In that-relatives, such as (11a-c), the raising element is a DP or NP and the head of CP is overtly filled by the relative pronoun *that*:

- (10) a. The announcement which John made  
 b.  $[_{DP} \text{ the } [_{CP} \text{ C}^0 \text{ John made } [_{DP} \text{ which } [_{NP} \text{ announcement } ] ] ] ] ] ] ]$   
 c.  $[_{DP} \text{ the } [_{CP} [_{DP} [_{NP} \text{ announcement } ]_i \text{ which } t_i ]_j \text{ C}^0 \text{ John made } t_j ] ] ] ] ]$
- (11) a. The announcement that John made  
 b.  $[_{DP} \text{ the } [_{CP} \text{ that John made } [_{NP} \text{ announcement } ] ] ] ] ]$   
 c.  $[_{DP} \text{ the } [_{CP} [_{DP/NP} \text{ announcement } ]_j \text{ that John made } t_j ] ] ] ] ]$

One of the well-known arguments for assuming that nominal heads of relative clauses are created by movement from inside the relative clauses is provided by reconstruction cases such as the following:

- (12) a.  $\text{John}_i \text{ told } [ \text{ stories about himself}_i ]$

---

<sup>2</sup> The reasons for treating relative clauses as complements of functional rather than lexical heads, and for assuming that  $D^0$  is the most plausible functional head, are discussed in Kayne (1994) and Bianchi (1999). A more elaborate discussion of these reasons is beyond the scope of this paper and the reader is referred to the literature.

<sup>3</sup> The latter view has been criticised severely by Borsley (1997). Some discussion on the identity of the moving element can also be found in Alexiadou et al (2000:16ff.).

- b. Bill liked the [ stories about himself<sub>i</sub> ] which John<sub>i</sub> told
- c. \*Bill liked the [ stories about him<sub>i</sub> ] which John<sub>i</sub> told

In (12b), the nominal head *stories about himself* contains an anaphor which is bound by the subject of the relative clause: the well-formedness of (12b) is expected if the nominal head originates from inside the relative clause (the raising analysis), but unexpected if it is base-generated outside this clause (the complement-of-N<sup>0</sup> analysis - but see Platzack 2000). For the same reason, only the raising analysis predicts that (12c) should be ill-formed (i.e. that the nominal head cannot contain a pronoun which is bound by the subject of the relative clause).

### 3 Extraposition

In the previous section, I discussed two different lines of analysis for restrictive relatives which are compatible with Kayne's antisymmetric approach and the LCA. Extraposition phenomena are problematic for both systems because extraposed relatives appear to the right of their normal, canonical positions. But within LCA-based systems, extraposition cannot be accounted for in terms of rightward movement of the relative clauses, because rightward movement in general is disallowed; for more discussion, see e.g. Kayne (1994:117f.).

Many grammarians, including Kayne, have tried to explain extraposition structures like (1), repeated here as (14), in terms of leftward movement of the nominal head and stranding of the relative clause in situ. An alternative line of analysis, put forward by e.g. Platzack (2000), is to assume that the "normal" structures in (13) and extraposition structures in (14) have different base generated structures:

- (13) a. [ A letter which was addressed to Mary ] arrived yesterday
- b. [ A handsome man who looked like Ewan McGregor ] walked into the room
- (14) a. [ A letter ] arrived yesterday [ which was addressed to Mary ]
- b. [ A handsome man ] walked into the room [ who looked like Ewan McGregor ]

In section 3.1. I discuss leftward movement and stranding, as well as the idea that relative clause extraposition structures are base generated, within the complement-of-N<sup>0</sup> approach. In section 3.2. I review Kayne's view of extraposition phenomena as leftward movement and stranding. In section 4, I move on to look at some alternative analyses of restrictive relative clauses which are compatible with the antisymmetric approach, to see if they are able to provide more economical and/or unproblematic accounts of extraposition phenomena.

#### 3.1 The Complement-of-N<sup>0</sup> Approach

Within this system, we have seen that restrictive relatives are analysed as complements of lexical N<sup>0</sup>s. On the view that premodifying adjectives are specifiers of NPs or of some DP-internal functional projections (see e.g. Abney 1987; Szabolczi 1987; Cinque 1994; Laenzlinger 2000), the examples in (13)-(14) have the (simplified) pre-movement structures illustrated in (15):

(15)

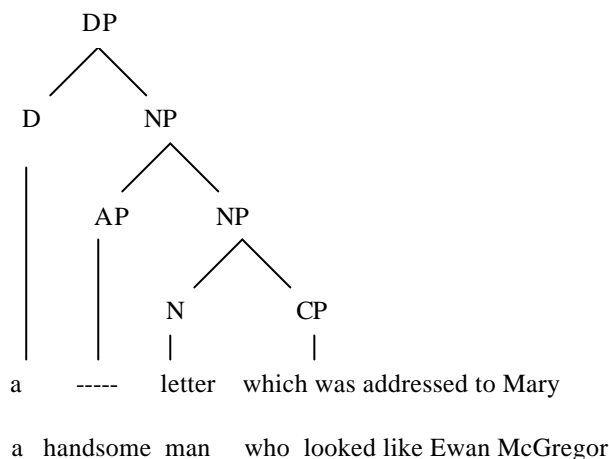

I begin by discussing the idea that extraposition structures are created by moving the nominal head of the relative clause to the left, so that the rest of the relative clause is stranded in situ. It is relatively uncontroversial that, in the same way as in (13), the nominal heads *a letter* and *a handsome man* in (14) have raised to Spec,TP to check nominative case and the uninterpretable EPP feature of T. But as shown in (15), the problem is that the indefinite article *a*, the premodifying adjective *handsome* and the N<sup>0</sup> head *letter/man* do not form a constituent which can move.

The first solution that suggests itself is that somehow the whole DP raises to Spec,TP, leaving behind a copy. After the relevant items have been deleted at PF, the indefinite article, premodifying adjective and N<sup>0</sup> head can be pronounced in the derived position, the complement phrase in the base position:

- (16) a. [TP [DP A letter ~~which was addressed to Mary~~] arrived yesterday [DP ~~a letter~~ which was addressed to Mary ]]
- b. [TP [DP A handsome man ~~who looked like Ewan McGregor~~] walked into the room [DP ~~a handsome man~~ who looked like Ewan McGregor ]]

There are numerous reasons to reject this possibility. First, it is against the restrictive nature of the theory to say that sometimes the whole DP is pronounced in the derived position (e.g. 13 above), and sometimes only the nominal head is pronounced there (e.g. 14). Second, in (13), the DPs *a letter which was addressed to Mary* and *a handsome man who looked like Ewan McGregor* function as subjects. The fact that they bear Agent theta roles suggests that their original position of merge is high up in the VP shell (cf. the hierarchy of thematic roles discussed in e.g. Larson 1988; Grimshaw 1990; Koizumi 1995; Stroik 1995), and that they undergo movement to Spec,TP. There are no apparent reasons to believe that the DPs in (14) have a different status (i.e. that they are not subjects bearing Agent theta roles) from those in (13). But if the original position of these DPs is high up in the VP shell, then we would expect the stranded relative clauses to be spelled out in *that* position, rather than in the sentence-final position. The well-formedness of (14) and ill-formedness of (17) show however that the relative clauses cannot be spelled out in any other position except the sentence-final one:

- (17) a. \*[ A letter ] arrived [ which was addressed to Mary ] yesterday

- b. \*[ A handsome man ] walked [ who looked like Ewan McGregor ] into the room

In order to account for this fact, we could assume that all elements which are merged lower down in the VP-shell - in (14) these would include the lexical V and the VP internal adverbials *yesterday* and *into the room* - must move across the stranded relative clauses to an appropriate higher position. But this line of reasoning is problematic for a minimalist theory as it introduces a number of movement operations which do not take place anywhere else. Second, it is unclear why the movement operations are obligatory only in (14) where the relative clauses are stranded in place, but not in (13) where the relative clauses have moved to Spec,TP together with the superordinate DP. Third, it is not immediately obvious what features drive this movement and what the derived positions of the moved elements are. This is important because the moved elements often have the form of adverbial AdvPs and PPs which are not normally associated with uninterpretable features in need of checking. Finally, it is questionable whether *yesterday* is a VP internal adverbial which can move across the relative clause - see e.g. Alexiadou (1997) and Koster (2000) for some relevant discussion.

An alternative way to explain extraposition data such as (14) could be to say that we are dealing with remnant movement.<sup>4</sup> In remnant movement, an element X moves out of a larger constituent YP to an appropriate higher position. At a later stage in the derivation YP, which now contains the trace of X, moves across X to an even higher position:<sup>5</sup>

- (18) a. [YP ... X ... ]  
 b. [YP ... t<sub>i</sub> ... ]<sub>j</sub> ... [ ... X<sub>i</sub> ... [ ... t<sub>j</sub> ... ]]

In (14), we could assume that the relative CP has raised from the superordinate NP and DP to an appropriate higher position. At a later stage in the derivation, the remaining material, consisting of the D<sup>0</sup> head *a*, the premodifying adjective *handsome*, the N<sup>0</sup> head *man* and the trace of CP, then raises across the CP to an even higher position, producing the correct hierarchical structure and linear order. The derived structures of (14a-b) are given in (19a-b):

- (19) a. [DP a [NP letter t<sub>i</sub> ]]<sub>j</sub> ... [ ... CP<sub>i</sub> ... [ ... t<sub>j</sub> ... ]]  
 b. [DP a [NP handsome man t<sub>i</sub> ]]<sub>j</sub> ... [ ... CP<sub>i</sub> ... [ ... t<sub>j</sub> ... ]]

However, although in (19) all moving elements form a constituent, the question that immediately arises is what drives the movement of the relative CP out of the superordinate NP and DP, and what is its landing site. Second, the optional nature of this movement operation is a problem for a minimalist theory of language: why does the CP move in (14), but not in (13)? One avenue of explanations that suggests itself is that CP raises to some focus-related functional projection (possibly for pragmatically “heavy” elements); but the question that remains is why the CP only raises there in (14), and not in (13). I will leave this possibility open for future research.

A further problem for the idea that extraposition constructions are created by leftward movement and stranding of the relative clause is that extraposition is usually only possible when the nominal head is indefinite. Compare (14) with (20):

- (20) a. ??[ The letter ] arrived yesterday [ t which was addressed to Mary ]

<sup>4</sup> E.g. Fox (2002) suggests in passing that QR to the right could perhaps be reformulated as remnant movement to the left. I will leave this option open for further research.

<sup>5</sup> Remnant movement raises a number of questions (for example, how is it possible for X’s trace not to be c-commanded by X). For more discussion on these questions, and on remnant movement in general, see e.g. the various papers in Alexiadou et al (2001).

- b. ??[ The handsome man ] walked into the room [ t who looked like Ewan McGregor ]

It is standardly assumed that both indefinite and definite articles appear in D. But if both (14) and (20) have the underlying structure illustrated in (15) above, then the contrast between these sentences is unexpected - see e.g. Gueron & May (1984), Kayne (1994:118ff.), and Bianchi (1999:264ff) for further discussion. See also section 3.2. below.

Instead of movement, Platzack (2000) has argued that data such as (13)-(14) have different base generated structures. Within Platzack's system, "normal" restrictive relatives are complements of lexical  $N^0$ s. Extraposed relatives, on the other hand, are complements of phonologically empty  $N^0$ s. The relative complementiser raises from  $C^0$  to the phonologically empty  $N^0$ , and the resulting  $C^0+N^0$  complex raises to the superordinate  $D^0$ . The nominal head of the relative clause is, in turn, merged directly in its matrix clause position. In (21)-(22), from Platzack (2000:287), we see how the nominal heads *den* and *den flicka* are merged directly in their matrix clause positions, while the relative clauses are merged in some low VP-internal position:

- (21) a. Den vill jag prata med som har stulit min cykel  
the want I talk with who has stolen my bike  
'I would like to talk to the one who has stolen my bike'

b. [TP Den vill jag prata med [DP [D0 som<sub>i</sub>] [NP [N0 t<sub>i</sub>] [CP Op<sub>j</sub> [C0 t<sub>i</sub>] [TP t<sub>j</sub> har stulit min cykel ]]]]]

- (22) a. Nu är den flicka här som du frågade efter  
Now is the girl here that you asked for  
'Now the girl is here that you were asking for'

b. [TP Nu är den flicka här [DP [D0 som<sub>i</sub>] [NP [N0 t<sub>i</sub>] [CP Op<sub>j</sub> [C0 t<sub>i</sub>] [TP du frågade efter t<sub>j</sub> ]]]]]

The English relative complementiser *that* behaves in the same way as the Swedish *som*. This means that, within Platzack's system, *that* can raise from  $C^0$  to a phonologically empty  $N^0$  and  $D^0$  - this is illustrated in (23b) below. In Wh-relatives, the relative pronoun could again be a kind of operator binding a trace, while the  $C^0$  position is empty (cf. 8a above). Like that-relatives, Wh-relatives could then also be selected by a phonologically empty  $N^0$ . The relevant structure is given in (24b):

- (23) a. A letter arrived yesterday that was addressed to Mary

b. [TP A letter arrived yesterday [DP [D0 that<sub>i</sub>] [NP [N0 t<sub>i</sub>] [CP Op<sub>j</sub> [C0 t<sub>i</sub>] [TP was addressed to Mary t<sub>j</sub> ]]]]]

- (24) a. A handsome man walked into the room who looked like Ewan McGregor

b. [TP A handsome man walked into the room [DP D [NP N [CP who<sub>j</sub> [CP C<sup>0</sup> [TP t<sub>j</sub> looked like Ewan McGregor ]]]]]]]

Platzack's system is able to avoid some of the problems associated with approaches analysing extraposition as movement and stranding of the relative clause in situ: the identity of the moving element is not a problem, because there is no movement. Second, his system



explains, in a relatively straightforward way, why the extraposed relative clause appears sentence-finally (i.e. the relative DP “is in a complement-head relation to (the trace of) the matrix verb (the lowest V in an Larsonian shell-structure).” (Platzack 2000:288)). Because Platzack’s system is based on Swedish, where even definite heads seem to be able to separate from the relative clauses, it is not clear to me how it would account for the contrast between data such as (14) and (20) above. I leave this open for future research.

### 3.2 The Raising Analysis

Within the raising analysis, the intermediate structure of (13)-(14) is the one given in (25) below. In this structure, the nominal head has raised to Spec,DP and the DP has raised to Spec,CP. The CP has then been selected by an external  $D^0$  as a complement:

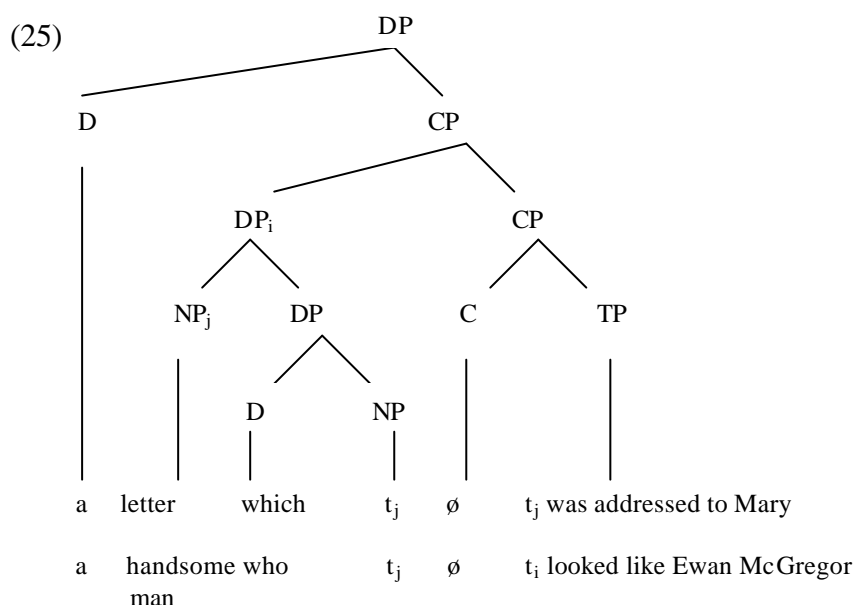

But the data in (14) are problematic also for the raising analysis. First, (25) shows that, because the indefinite article *a* heads the external DP, it cannot form a constituent with the nominal head *handsome man*. Given that *a* and *handsome man* do not form a constituent, they should not be able to move together either. A related problem, pointed out by Borsley (1997), is that the relative D *who*, which forms a constituent with the nominal head *handsome man*, cannot raise together with *handsome man* to Spec,TP:

- (26) a. \*[ A letter which ] arrived yesterday [ t addressed to Mary ]  
 b. \*[ A handsome man who ] walked into the room [ t looked like Ewan McGregor ]

To explain the well-formedness of extraposition data such as (14), Kayne (1994:124f.) and Bianchi (1999:264) have argued that the indefinite article *a* is a type of quantifier selecting an NP as its complement. More specifically, they propose that, instead of (25), the pre-movement structure of (14) is the one given in (27a) below. The intermediate structure is that given in (27b), while the derived structure is given in (27c):

- (27) a. [DP D [CP C ... [DP wh- [QP a NP ]]]]

- b. [DP D [CP [DP [QP *a* NP ]<sub>i</sub> [DP *wh-* t<sub>i</sub> ]]<sub>j</sub> [CP C ... t<sub>j</sub> ]]]  
 c. [TP [QP *a* NP ]<sub>i</sub> ... [CP [DP t<sub>i</sub> [DP *wh-* t<sub>i</sub> ]]<sub>j</sub> [CP C ... t<sub>j</sub> ]]]

Borsley (1997) has pointed out however that movement of QPs from Spec,CP to Spec,TP (i.e. from an A-bar position to an A-position) constitutes improper movement. Bianchi (2000) argues against this view, by stating that some Spec,CP positions are L-related positions and therefore comparable to any “normal” A-position - cf. Chomsky (1995:196, fn34) for further discussion on L-relatedness and the relation between L-relatedness and A-positions.

Further, to explain the contrast between (14) and (20) above, Kayne and Bianchi have argued that, unlike the definite article *a*, the definite article *the* is usually a determiner heading the external DP. On this view, the ill-formedness of (20) follows from that fact that, given the intermediate structure in (25), *the* and the nominal head *handsome man* do not form a constituent which can move. However, the well-formedness of (28), from Alexiadou et al (2000:19), strongly suggests that even definite articles can sometimes be quantifiers which are included in Spec,CP along with the rest of the nominal head:

- (28) a. We will discuss [ the announcement ] tomorrow [ t that John made yesterday ]  
 b. We will see [ the boy ] tomorrow [ with t whose mother I spoke ]

Interestingly, a comparison between (20) and (28) suggests that a definite nominal head can be separated from the relative clause more easily when it raises to a non-subject position (e.g. Spec,AgrOP instead of Spec,TP). At this stage, it is unclear to me why this is the case, and there is little discussion of this in the literature. One possible explanation, although not a very attractive one, could be that *a* and *the* head different types of QPs which have different distributions (e.g. possibly due to some pragmatic factors). I will leave this question open for future research.

In Section 3.1. we have seen that stranded relative clauses must always appear in sentence-final positions (compare e.g. (14) and (17) above). This is also a problem from the raising analysis, because the elements merged to lower VP-internal positions must raise across the stranded relative clauses, to the appropriate clausal functional projections:

- (29) a. [ A man who looked like Ewan McGregor ] walked into the room  
 b. [ A man ]<sub>i</sub> [ walked ]<sub>j</sub> [ into the room ]<sub>k</sub> [ t<sub>i</sub> who looked like Ewan McGregor ] t<sub>j</sub> t<sub>k</sub>

Bianchi (2000) offers two possible explanations for the well-formedness of (14) and ill-formedness of (17). On the one hand, she points out that in (14), the external D<sup>0</sup> selecting the relative CP is not filled by phonologically overt material. She argues that such DPs can only be licensed in low VP internal non-theta positions which in linear ordering often correspond to sentence-final positions. Further, because the DPs appear low down in the VP-shell, even PPs can scramble across them.

- (30) a. [QP A letter ] arrived yesterday [ DP e [CP t which was addressed to Mary ]  
 b. [QP A handsome man ] walked into the room [DP e [CP t who looked like Ewan McGregor ]]

Another (related) possibility is that (14) is derived from (13) by means of prosodic scrambling (in the sense of Zubizarreta 1998). In other words, when constituents are reordered in the PF component of the grammar, all phonologically heavy elements (which is what relative clauses undoubtedly are) are placed sentence-finally.

## 4 Alternative Analyses

In this section, I discuss some alternative accounts of restrictive relatives and extraposition phenomena which are compatible with Kayne's antisymmetric approach and the LCA. In section 4.1. I introduce the idea that relative clauses are specifiers of layered NPs/nPs. In section 4.2. I outline briefly Koster's (2000) proposal that extraposition constructions are examples of the so-called parallel structure. In Section 4.3. I discuss the idea that relative clauses are DPs which have the nominal head as specifier and the relative CP as complement. Rather than present any fully worked-out systems, my aim here is to try out different ideas and see where they lead.

### 4.1 Specifiers of NPs/nPs?

In the discussion so far, I have reviewed systems which treat relative clauses as complements of lexical  $N^0$ s (e.g. Platzack 2000), or as complements of functional  $D^0$ s (e.g. Kayne 1994; Bianchi 1999, 2000). According to Kayne (1994:87), these are the only systems which are available within an LCA-based theory. However, the LCA *does* allow for a third option as well: relative clauses could be specifiers of appropriate lexical or functional heads (e.g. of NPs or nPs) within the nominal domain. On the view that relative clauses are specifiers of lexical NPs, the Wh- and that-relatives *the man who looked like Ewan McGregor* and *the announcement that John made* (cf. (7)-(8) above) have the derived structures given in (31a-b). Inside the relative CPs, the relative pronoun *who* is again a kind of operator in Spec,CP which binds a trace, and the  $C^0$  position is empty. In that-relatives, the Spec,CP position is filled by a null operator and the  $C^0$  position is filled by the relative complementiser *that*:

- (31) a.  $[_{DP} \text{ the } [_{NP} \text{ man}] [_{NP} \text{ CP } [_{NP} \text{ t}_i ]]]$   
 b.  $[_{DP} \text{ the } [_{NP} \text{ announcement}] [_{NP} \text{ CP } [_{NP} \text{ t}_j ]]]$

In (31a-b), the relative clause is in Spec,NP and the  $N^0$  head *man/announcement* has raised across it, to an appropriate higher head position. I have labelled this position n, to indicate that NPs could have a layered structure and that lexical  $N^0$ s could move and adjoin to functional  $n^0$ s, in the same way as VPs have a layered structure and lexical  $V^0$ s move and adjoin to functional  $v^0$ s.

Given the structure and explanations in (31a-b), relative clause extraposition data such as (14) can be accounted for in (at least) two different ways. On the view that NPs have a layered structure, then both attributive APs and relative clauses are in the specifier positions within the NP domain, while nominal complements are in the complement of N position. If we (tentatively) assume that relative clauses appear in the highest NP layer, then we could hypothesize that the  $N^0$  and attributive APs move across the relative clauses to some higher positions (possibly to check their F-agreement features against the appropriate functional heads; cf. Abney 1987; Szabolczi 1987; Cinque 1994; Laenzlinger 2000, among many others). Alternatively, the lower NP as a whole could raise across the relative clause, to an appropriate DP-internal specifier position; in this case however it is less clear what drives the movement of the NP.

While the line of reasoning pursued above is able to account for the structure of NPs (DPs) containing restrictive relatives, problems arise when we look at extraposition data such as (14). (32) represents the underlying structure of the DPs in (14). It shows that, even after movement, the  $D^0$  head *a*, the attributive AP *handsome* and the lexical  $N^0$  *letter/man* do not form a constituent which can move onwards to a superordinate Spec,TP, stranding the

relative clause in its original Spec,NP position:

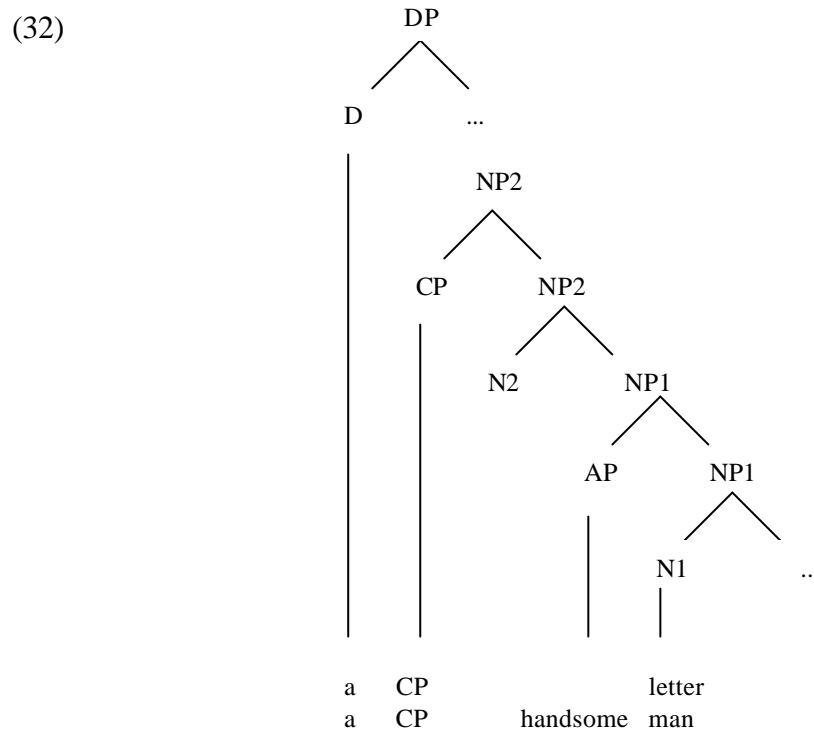

Further, in order to explain why extraposed relatives must always occur sentence-finally, we are again forced to assume that the DPs in (14) appear low down inside the VP, and that even adverbials AdvPs and PPs can sometimes scramble across them. Finally, the contrast between (14) and (20) does not receive a straightforward explanation within this theory.

#### 4.2 Parallel structure?

Koster (2000) has proposed that phrase structure in general takes two forms: primary phrase structure and parallel structure. Although both forms consist of a specifier, head and complement, they are licensed in different ways. In primary structure, projections of lexical heads are selected by functional heads as their complements (e.g. V is selected by v, N is selected by D, and so on). The elements of parallel structure, Koster argues, are in turn licensed by linking them to elements in the primary structure.

Coordinative constructions are often assumed to have the form of parallel structure. The following Dutch data are from Koster (2000:16):

- (33) a. Zij heeft [ Marie en mij ] gezien  
 She has Mary and me seen  
 ‘She has seen Mary and me’
- b. Zij heeft [ Marie ] gezien [ en mij ]  
 She has Mary seen and me  
 ‘She saw Mary and me’

In (33a), the DP *Marie* and its parallel extension *en mij* are adjacent and, Koster argues, have the following structure:<sup>6</sup>

- (34) a. [ DP [ and DP ] ]  
 b. [ [DP Marie ] [ en [DP mij ] ] ]

In structures such as (34), Koster (2000:18) argues, *and/en* is a head selecting the second DP (*mij*) as its complement. The first DP (*Marie*) in the specifier position checks some relevant features of the *and/en* head (or of the [*and DP*] complex). This checking relation between the specifier and the head, Koster further argues, is what licenses the parallel structure:

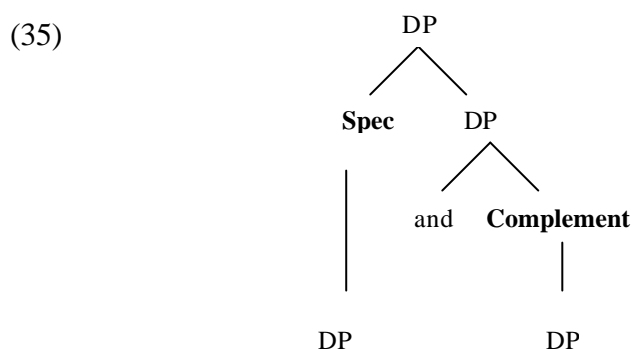

One might wonder how the relation between the specifier and the *and/en* head licenses the parallel structure within the most recent generative frameworks, because the specifier-head relation is not warranted any special status within these systems - see e.g. Chomsky (1999; 2000; 2001) for discussion. Setting this question aside, Koster (2000:18) continues by proposing that the parallel structure as a whole “usually has the categorial status of its specifier.” He argues that this proposal receives support from data such as (33a), where the parallel structure as a whole has undergone object shift to the appropriate clausal functional projection. This suggests that the parallel structure must be an element which bears case and therefore is able to check the uninterpretable EPP features of a functional AgrO head.

Returning to the extraposed structure in (33b), Koster argues that the DP *Marie* is embedded inside a functional AgrOP. The AgrOP is the specifier of the parallel structure, checking the relevant features of the head *and/en*. The parallel extension *mij* is again complement of the *and/en* head. The accusative case of *mij*, Koster (2000: 16) further argues, is not assigned directly by some clausal functional head. Instead, it is assigned *indirectly*, via its linking to the DP *Marie* (which receives case from the verb *gezien*). The simplified structure of (33b) is given in (36):

- (36) Zij heeft [<sub>AgrOP</sub> [<sub>AgrOP</sub> Marie gezien ] [ en [<sub>DP</sub> mij ] ] ]

Although in (36), the DP *Marie* is embedded inside the AgrOP, Koster argues that it is still able to enter into a checking relation with the *and/en* head. A similar situation is illustrated in (37)(from Koster 2000:18f.) where the Wh-element *whom*, which is embedded inside a PP, checks the uninterpretable Wh-feature of the C<sup>0</sup> head:

<sup>6</sup> Koster (2000) speaks of NPs while I speak of DPs. It makes no difference to the argumentation here whether the category in question is an NP or a DP.

(37) [CP [PP with [NP whom]]<sub>i</sub> [[+wh] [did [you talk  $t_i$  ]]]]



Koster (2000:20ff.) applies his theory of parallel structure to cover also cases of asyndetic coordination and equative constructions - the example in (38) is from Koster (2000:21):

(38) John built something beautiful: a golden igloo

Here the parallel extension *a golden igloo* is only licensed via its linking to the DP *something beautiful*, in the same way as *mij* in (33) is licensed via its linking to *Marie*. Koster argues that data like (38) have the same structure as the data in (33), and proposes that in most examples of parallel structure, there is no overt head like *and/en*. This is why he re-labels the head of a parallel structure : (colon). Crucially, Koster (2000:22) argues that the colon “indicates set intersection in the case of restrictive relative clauses” and “the relative clause gives a further specification of the head of the relative clause placed in the Spec of colon.”

After this introduction to parallel structures, I try to apply the system to English extraposed restrictive relatives. I begin though by examining the following Dutch examples (from Koster 2000:23):

(39) a. Ik heb [DP [DP een vrouw ] [ : [CP die alles wist ]]] gezien  
 I have a woman who everything knew seen  
 ‘I saw a woman who knew everything’

b. Ik heb [AgrOP [AgrOP een vrouw gezien ] [ : [CP die alles wist ]]]

In (39a), the DP *een vrouw* and its parallel extension *die alles wist* are adjacent, and the parallel structure as a whole has the status of a DP (i.e. the direct object). In (39b), the DP *een vrouw* and its parallel extension *die alles wist* are separated by the lexical V *gezien*. Because the DP is also embedded inside an AgrOP, the parallel structure as a whole has the status of an AgrOP. The structure of the English examples in (14) is given in (40):

(40) a. . [TP [TP A letter arrived yesterday ] [ : [CP which was addressed to Mary ]]]

b. [TP [TP A handsome man walked into the room ] [ : [CP who looked like Ewan McGregor ]]]

In (40), the parallel structure as a whole has the status of a TP, and the TPs *A letter arrived yesterday* and *A handsome man walked into the room* appear in its specifier position. The DPs *A letter* and *A handsome man*, which are embedded inside the TPs, are in turn linked with the parallel extensions (i.e. to the CPs) *which was addressed to Mary* and *who looked like Ewan McGregor*, thus licensing their presence.

The line of reasoning pursued above seems attractive, at least at first sight. First, it is able to account for extraposition phenomena in a straightforward way: the identity of the moving element is not a problem because there is no movement. It also explains why extraposition constructions fail to exhibit properties normally associated with movement, and why extraposed relatives must always appear sentence-finally. On the other hand, it is less clear how the system explains the contrast between data such as (14) and (17). Another problem is that, in section 2, we have seen how reconstruction supports the idea that the

nominal heads of relative clauses are created by movement from inside the relative clauses. The relevant examples are repeated here as (41):

- (41) a. John<sub>i</sub> told [ storied about himself<sub>i</sub> ]  
 b. Bill liked the [ stories about himself<sub>i</sub> ] which John<sub>i</sub> told  
 c. \*Bill liked the [ stories about him<sub>i</sub> ] which John<sub>i</sub> told

If relative clauses are now examples of parallel structure, then (41b-c) must have the structures illustrated in (42):

- (42) a. Bill liked [<sub>XP</sub> [<sub>DP</sub> the stories about himself<sub>i</sub> ]][ X [<sub>CP</sub> which John<sub>i</sub> told ]]  
 b. Bill liked [<sub>XP</sub> [<sub>DP</sub> the stories about him<sub>i</sub> ]][ X [<sub>CP</sub> which John<sub>i</sub> told ]]

Above, it was mentioned that elements in the parallel extension can be assigned case via their linking to the DP in the specifier position. We would not expect the system to work the other way around though, so that properties of some elements inside the DP are determined via their linking with a parallel extension. Crucially, given the structures in (42), we would not expect the anaphors inside the DPs to be bound by the subjects of the relative clauses.

### 4.3 DPs?

In this section, I try to combine the two different ideas discussed above, namely the view that relative clauses are specifiers of appropriate lexical or functional heads within the NP domain, and that they appear in some kind of “parallel-like” structure. The line of reasoning developed here also makes use of the idea discussed in e.g. Bianchi (1999; 2000) and Platzack (2000:274) that the nominal head of the relative clause sometimes raises to the superordinate Spec,DP.

The type of structure I am proposing is illustrated in (43) below. I will leave it open, at stage, whether the nominal head is raised to the Spec,DP position or whether it is base generated there (the former line of reasoning would explain straightforwardly why in languages like English, the nominal heads can be reconstructed back into the relative clauses, while the latter idea would explain why in languages like Finnish, they cannot):<sup>7</sup>

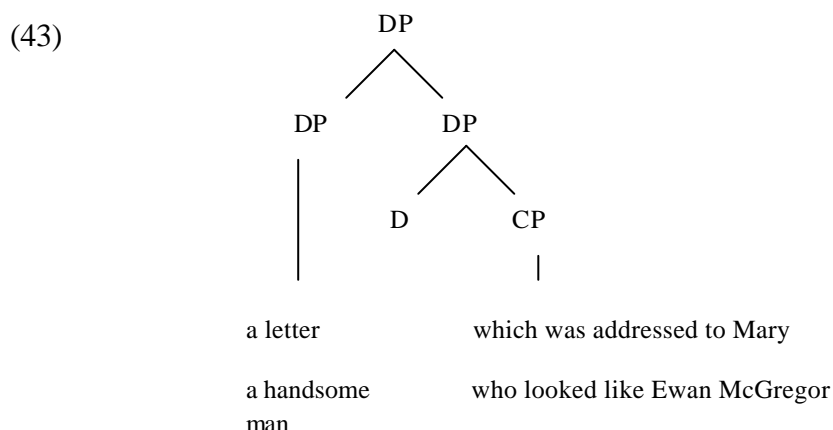

<sup>7</sup> If the DPs are base generated in Spec,DP then the CP probably contains an operator - cf. the examples in (7) and (8) above. If the DPs raise to Spec,DP from inside the relative clauses, then there is a copy/trace of DP in the relevant position inside the CP.

The structure illustrated in (43) is similar to that often assigned to genitive constructions - for more discussion of genitives, see e.g. Abney (1987); Szabolcsi (1987); Zamparelli (2000).<sup>8</sup> The idea is then that relative clauses appear inside of “relativising” DPs, while genitives appear inside of genitive DPs:

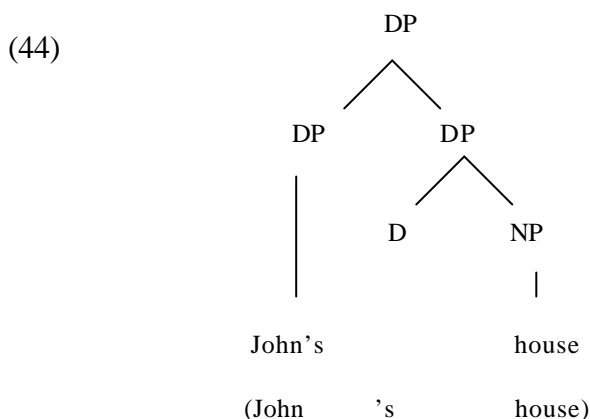

But this line of reasoning does not really solve anything. Although it is possible to say that the moving element is always a DP and the movement strands the relative CP in situ, it is unclear why sometimes only the DP in the specifier position moves (e.g. 14 above), and why sometimes the whole relative DP moves (e.g. 13). Secondly, to explain the well-formedness of (14) and ill-formedness of (17), we are again forced to assume that the relative DP is merged to some low VP internal projection. Third, it is still unclear why indefinite and some definite DPs behave differently with regard to extraposition phenomena (cf. the contrast between (14) and (20) discussed above).

## 5 Concluding remarks

The purpose of this paper was to review and evaluate some LCA-based analyses of restrictive relative clauses, and to discuss the types of problems that they face in the analysis of extraposition phenomena.

We have seen that a number of approaches treat extraposition as leftward movement of the nominal head, and stranding of the relative clause in situ. But most of these approaches share the same problems: neither the identity of the moving element, nor the original position of merge of the DP that hosts it (i.e. the question why the stranded relative clauses are always sentence-final) is always clear. A further problem is the fact that indefinite and definite nominal heads behave very differently with regard to extraposition phenomena. Although solutions have been proposed to all these problems, many questions still remain unanswered. The idea discussed in Platzack (2000) that extraposition structures are base generated seems most promising, at this stage, especially if it can be combined with some aspects of Koster's

---

<sup>8</sup> Abney (1987) and Szabolcsi (1987) have argued that the phonologically empty D heads are associated with Agreement features and that they are responsible for assigning case to the possessive DPs in their specifier position. More recent researchers have proposed that, rather than inserted there directly, the possessive phrases could be *raised* to Spec,DP from inside the D's complement phrase. They further argue that D might be some other functional head than D. I will use the label D of both relativising and genitive heads, bearing in mind that these heads might in fact be of some other category.



(2000) parallel structure. Neither of these approaches analyses extraposition as leftward movement, so the identity of the moving element does not pose any problems. Whether these lines of analysis are superior to Fox & Nissenbaum's and Fox's analysis involving quantifier raising and late merge of the relative clause still remains to be seen.

## 6 References

- Abney, S. 1987. *The English Noun Phrase and its Sentential Aspect*, Ph.D. dissertation, MIT, Cambridge, Mass.
- Alexiadou, A. 1997. *Adverb Placement. A case study in antisymmetric syntax*, John Benjamins, Amsterdam.
- Alexiadou, A. et al. 2000. 'Introduction', in A. Alexiadou et al. (eds.), *The syntax of relative clauses*, John Benjamins, Amsterdam, pp 1-52.
- Alexiadou, A. et al. (eds). 2001. *Two types of remnant movement*, John Benjamins, Amsterdam.
- Bianchi, V. 1999. *Consequences of Antisymmetry: Headed Relative Clauses*, Mouton de Gruyter, Berlin.
- Bianchi, V. 2000. 'The raising analysis of relative clauses: a reply to Borsley', *Linguistic Inquiry* 31, 123-140.
- Borsley, R. 1997. 'Relative clauses and the theory of phrase structure', *Linguistic Inquiry* 28, 629-647.
- Carlson, G. 1977. *Reference to Kinds in English*, Ph.D. dissertation, MIT, Cambridge, Mass.
- Chomsky, N. 1977. 'On Wh-movement', in P. Culicover et al (eds), *Formal Syntax*, Academic Press, New York, pp 71-132.
- Chomsky, N. 1995. *The Minimalist Program*. The MIT Press, Cambridge, Mass.
- Chomsky, N. 1999. 'Derivation by phase', MITOPL
- Chomsky, N. 2000. 'Minimalist inquiries: the framework', in R. Martin et al (eds.) *Step by Step*. The MIT Press, Cambridge, Mass, pp 89-155.
- Chomsky, N. 2001. 'Beyond explanatory adequacy', Ms, MIT, Cambridge, Mass.
- Chomsky, N. & H. Lasnik. 1995. 'The theory of principles and parameters', in N. Chomsky, *The Minimalist Program*, The MIT Press, Cambridge, Mass, pp 13-127.
- Cinque, G. 1994. 'On the evidence for partial N-movement in the Romance DP', in Cinque et al. (eds.) *Paths towards universal grammar*, Georgetown University Press, Washington D.C.
- Fox, D. 2002. 'Antecedent-contained deletion and the copy theory of movement', *Linguistic Inquiry* 33, 63-96.
- Fox, D. & J. Nissenbaum. 1999. 'Extraposition and scope: a case for overt QR', in S. Bird et al (eds.) *WCCFL 18*. Cascadilla Press, Somerville, pp 132-144.
- Grimshaw, J. 1990. *Argument Structure*. The MIT Press, Cambridge, Mass.
- Gueron, J. & R. May. 1984. 'Extraposition and logical form', *Linguistic Inquiry* 14, pp 1-32.
- Halle, M. & A. Marantz. 1993. 'Distributed morphology', in K. Hale & S.J. Keyser (eds), *The View from Building 20*, The MIT Press, Cambridge, Mass, pp 111-176.
- Jackendoff, R. 1977. *X-bar Syntax: A Study of Phrase Structure*, The MIT Press, Cambridge, Mass.
- Kayne, R. 1994. *The antisymmetry of syntax*, The MIT Press, Cambridge, Mass.
- Koizumi, M. 1995. *Phrase Structure in Minimalist Syntax*, Ph.D. dissertation, MIT, Cambridge, Mass.
- Koster, J. 2000. 'Extraposition as parallel constual', Ms, University of Groningen.
- Larson, R. 1988. 'On the double object constructions', *Linguistic Inquiry* 18, pp 595-621.

- Laenzlinger, C. 2000. 'French adjective ordering: perspectives on DP-internal movement types', in E. Haeberli and C. Laenzlinger (eds.), *GG@G*, Vol 1, pp 55-104.
- Manzini, R. 1994. 'Syntactic dependencies and their properties: a note on strong islands', in J. Harris (ed), *UCL Working Papers in Linguistics* 6, pp 205-218.
- Platzack, C. 2000. 'A complement of N<sup>0</sup> account of restrictive and non-restrictive relatives: the case of Swedish', in A. Alexiadou et al. (eds.), *The syntax of relative clauses*, John Benjamins, Amsterdam, pp 265-308.
- Schachter, P. 1973. 'Focus and relativization', *Language* 49, pp 19-46.
- Stroik, T. 1995. *Scope, minimalism and VP structure*, Sage Publications, Thousand Oaks.
- Szabolcsi, A. 1987. 'The noun phrase', in F. Kiefer & K. Kiss (eds), *Syntax and Semantics 27: The Syntactic Structure of Hungarian*, Academic Press, San Diego, pp 179-274.
- Vergnaud, R. 1974. *French Relative Clauses*, Ph.D. dissertation, MIT, Cambridge, Mass.
- Zamparelli, R. 2000. *Layers in the Determiner Phrase*. Garland, New York.
- Zwart, J-W. 2000. 'A head raising analysis of relative clauses in Dutch', in A. Alexiadou et al. (eds.), *The syntax of relative clauses*, John Benjamins, Amsterdam, pp 349-385.