



LUND UNIVERSITY

Feature Valuation and the Role of Tense

Johansson, Mats; Jonas, Dianne

2006

[Link to publication](#)

Citation for published version (APA):

Johansson, M., & Jonas, D. (2006). *Feature Valuation and the Role of Tense*. Paper presented at 21st Comparative Germanic Syntax Workshop , Santa Cruz, CA, United States.

Total number of authors:

2

General rights

Unless other specific re-use rights are stated the following general rights apply:

Copyright and moral rights for the publications made accessible in the public portal are retained by the authors and/or other copyright owners and it is a condition of accessing publications that users recognise and abide by the legal requirements associated with these rights.

- Users may download and print one copy of any publication from the public portal for the purpose of private study or research.
- You may not further distribute the material or use it for any profit-making activity or commercial gain
- You may freely distribute the URL identifying the publication in the public portal

Read more about Creative commons licenses: <https://creativecommons.org/licenses/>

Take down policy

If you believe that this document breaches copyright please contact us providing details, and we will remove access to the work immediately and investigate your claim.

LUND UNIVERSITY

PO Box 117
221 00 Lund
+46 46-222 00 00

Structural Case, Feature Valuation and the Role of Tense

Mats Johansson & Dianne Jonas
Lund University & Yale University

1 Theoretical background

1.1 Case = uT on DP

Pesetsky & Torrego (P&T) (2004 a,b) propose an approach to structural case that involves a relation established during the course of the derivation between an interpretable T(ense)-feature on the category Tense, which is valued by the finite verb, and an uninterpretable T-feature on a DP; ϕ -features play no role in the valuation of Case-features, as they do e.g. for Chomsky (2001) – instead, structural Case is understood as the uninterpretable T-feature on DP, and no additional Case-feature is postulated. Case-marking thus reduces to valuation of the T-feature on DP.

1.2 Agree as feature sharing (P&T 2004b:4)

- (i) An unvalued feature F (a probe) on a head H at syntactic location α (F_α) scans its c-command domain for another instance of F (a goal) at location β (F_β) with which to agree.
- (ii) Replace F_α with F_β so that the same feature is present in both locations.

AGREE is strictly a relation between features. There is no reciprocal valuation between features on heads.

1.3 Notation

- a. $u\text{ val } T [1]$ = an uninterpretable valued instance of T which has undergone AGREE (e.g. with $iT [1]$)
- b. $iT []$ = an interpretable unvalued instance of T which has not undergone AGREE

1.4 A simple transitive clause

- (1) shows the structure after merging v .
- When V is tensed, it is *valued*, i.e. it has an uninterpretable *valued* Tense feature.

(1)

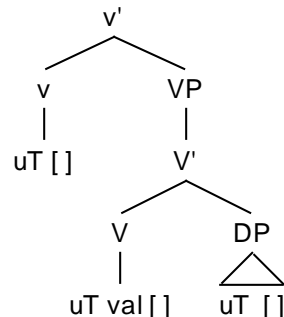

- T-valuation: step 1. Unvalued T on *v* probes and AGREES with valued T on V and unvalued T on the object DP. This Case-marks the object. In addition, the T-features are now instances of the same feature, as indicated by the shared index [1] in (2).

(2) The result of T valuation step 1

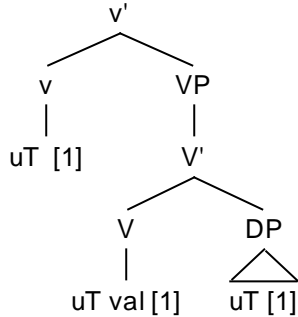

- (3) shows the structure after merging the subject in [Spec, *v*P] and Tns.
- T valuation: step 2: Unvalued T on Tns probes and AGREES with T on *v* and unvalued T on the subject DP. This Case-marks the subject.

(3) The structure after T valuation step 2

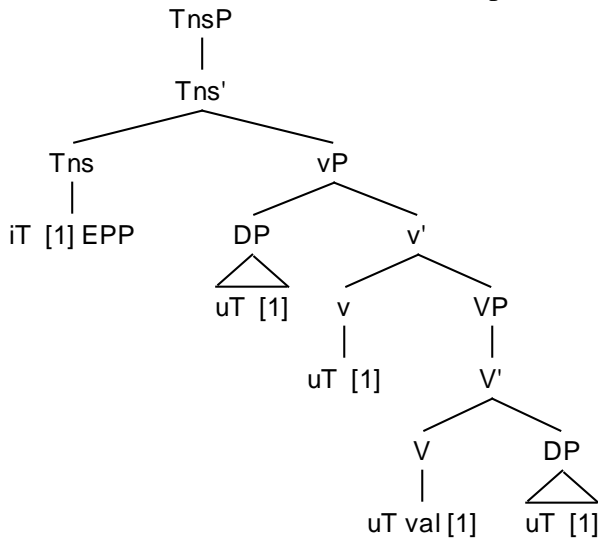

- Finally, the subject raises to [Spec, TnsP] to satisfy the EPP requirement of the T-feature on Tns.

Observations:

1. This process does not distinguish Nominative and Accusative. So, the syntax just cares about whether DPs have Case (valued T) or not. For an account of the spell-out of morphological case in P&T's framework see Platzack (2006).
2. The valued T-feature enters the derivation via the lexical verb. P&T (2004: fn. 4) suggest that languages may have invariably past tense verbs, which motivates locating the T value on the lexical verb. However, here we note that modal/auxiliaries carry tense

morphology. So, whenever an auxiliary is present the lexical verb presumably has an unvalued T-feature, and the T value is introduced on the finite auxiliary. This becomes important later when we provide an analysis of active and passive constructions with stacked auxiliaries. We argue that passives are, in fact, derivable in the same manner as active constructions with stacked auxiliaries.

2. A transitive clause with an auxiliary:

- Below in (4) we see the structure that obtains after merging *v*. An AGREE relation is established, but there is no valuation as the lexical verb is not tensed. P&T do not discuss structures with stacked auxiliaries.

(4) The structure after probing by T on *v*

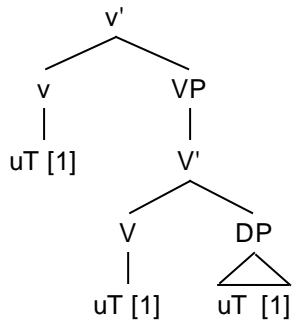

- The AGREE relation is created just as in (2) above but since the lexical verb is non-finite, there is no valuation of the T-feature.
- After merging the external argument in [Spec, *v*P] and subsequently the auxiliary, we get the structure in (5). The T-feature on the auxiliary, if finite, is *valued*.

(5)

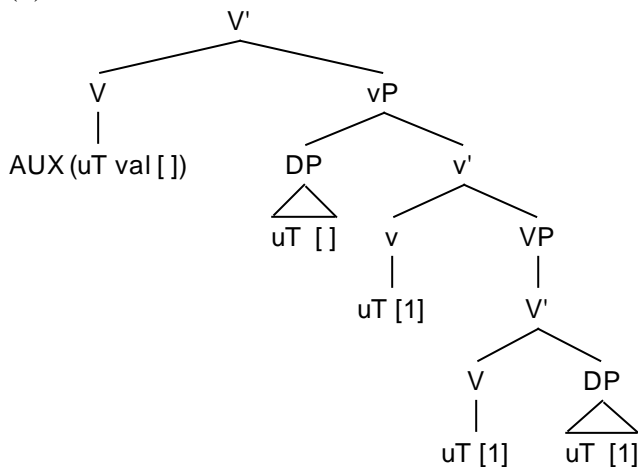

- There is no probing by T-features at this point in the derivation, since only unvalued features probe. As the next step in the derivation, Tense with an interpretable but unvalued Tense feature is merged as shown in (6).

(6)

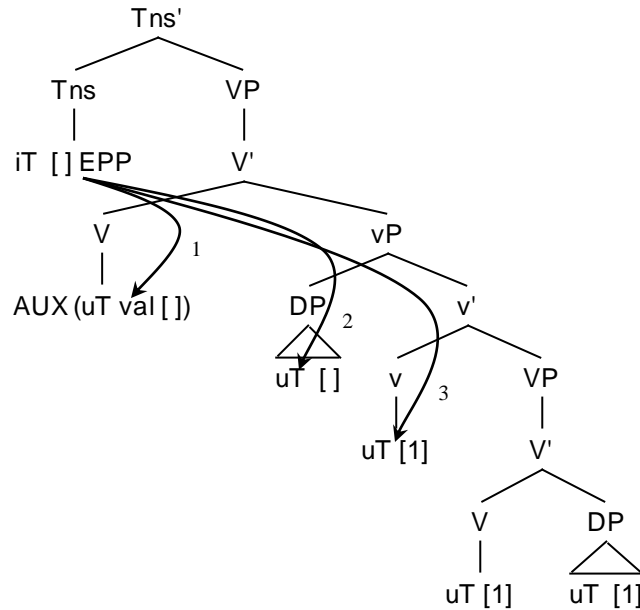

Since T on Tns is unvalued it probes. The following AGREE relations must be established:

- The interpretable T feature on Tense is valued by AGREE with the unvalued T feature on the auxiliary. (1)
- An AGREE relation also needs to be established between T on Tense and the subject DP in order to Case-mark the subject DP. (2)
- For the object to be Case-marked, an AGREE-relation also needs to be established with the T feature inside v'. (3)
- This requirement for object Case-marking thus entails that T on Tns will have to probe **THREE** times:
 1. T on Tns probes the auxiliary to get valued.
 2. T on Tns probes the subject DP and the subject is Case-marked
 3. T on Tns probes the uninterpretable T feature on v. This final probing step allows Case-making of the object DP once the AGREE relation is established between T on Tns and uT on v.

3 Raising (Pesetsky and Torrego 2005)

For a Raising construction with a non-finite complement clause, P&T propose an analysis where Tense in both the non-finite and finite clause has a matching value following establishment of a feature chain that connects the two clauses. Establishment of the connection between the two

clauses allows structural Case (uninterpretable T) on the subject to be valued as a consequence of a feature sharing relation with the finite raising verb. Under P&T's (2004b) analysis, valuation of the uninterpretable T-feature on the DP subject of the non-finite clause (= nominative case assignment) may take place prior to the final raising of DP to the specifier of finite matrix Tense. This aspect of their proposal is important to the analysis of raising constructions presented here in which multiple subject positions are available.

In (7), we see the derivation of a Raising construction with the subject raised out of a transitive clause.

(7a)

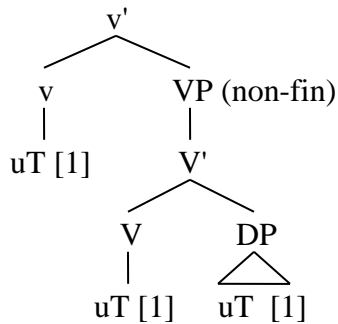

In (7a), we have the result after probing by *v* of unvalued T on V and on the object DP. Merging of the subject DP and non-finite Tns results in the structure in (7b). T on non-finite Tns probes the subject DP and *v*, establishing a feature chain. The subject raises to [Spec, TnsP] (possibly higher). Finally, (7c) shows the structure after merging of the finite Raising verb and the matrix Tense. Matrix Tens probes the finite Raising verb and the Raised subject, valuing the distributed T feature on all nodes.

(7b)

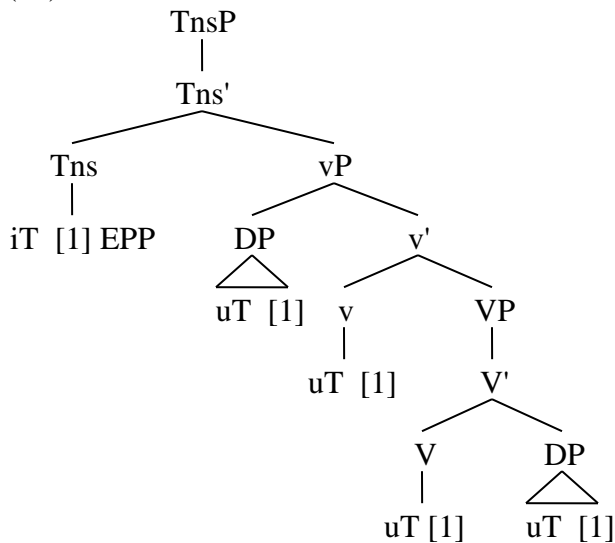

(7c)

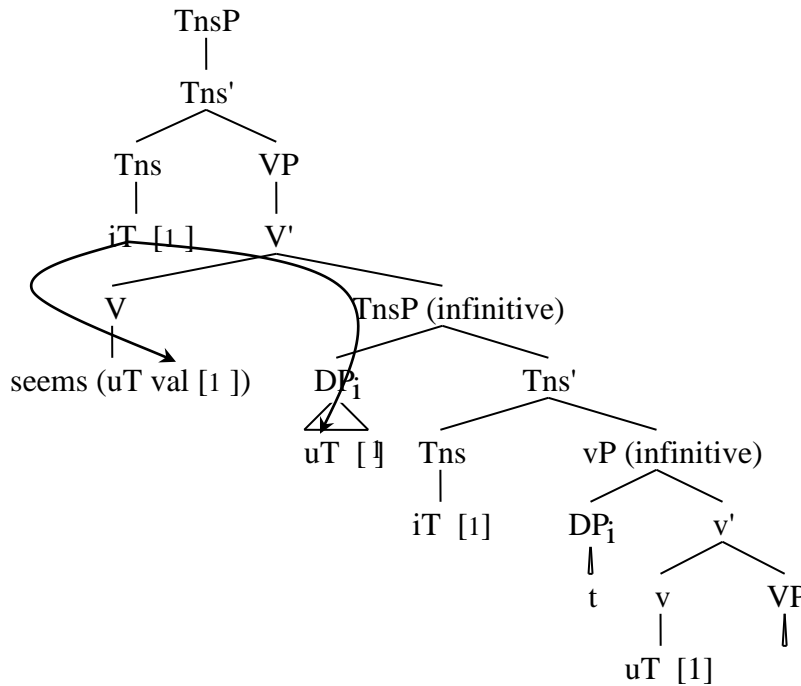

2. THE DATA

2.1 Raising constructions

- Raising in Swedish

In Swedish, *verka* ‘seem’ takes a *vP* or *VP* non-finite complement. There is no infinitival marker and the non-finite complement cannot be negated (8a, b).

- (8) a. *Det hade verkat att vara många män här.
 there had seemed to be[-FIN] many men here
- Sw. b. *Det hade verkat inte vara många män här.
 there had seemed not be[-FIN] many men here

In (9), we see that while unaccusatives freely occur in the non-finite complement clause of a raising verb (9a,b); verbs with an external argument are permitted only if the external argument of the verb in the complement clause raises to matrix subject position, it cannot stay low in the complement clause (9c-f).

- (9) a. Det hade verkat [_{VP} vara många män här].
 there had seemed be[-FIN] many men here

- b. Det verkar ha upstått några problem med vår analys.
there seem have[-FIN] arisen some problems with our analysis.
- c. *Det hade verkat några rådjur ha ätit blommorna.
there had seemed some deer have[-FIN] eaten flowers-the.
- d. Några rådjur hade verkat ha ätit blommorna.
some deer had seemed have[-FIN] eaten flowers-the
- e. *Det verkar många män sjunga i den här kören.
there seem many men sing[-FIN] in this choir
- f. Många män verkar sjunga i den här kören.
many men seem sing[-FIN] in this choir

- **Raising in Icelandic**

In raising constructions in Icelandic, the raising verb selects a non-finite ν P complement and, similarly to Swedish, the infinitival marker *að* is not present (10a), as in Swedish, the complement clause cannot be negated as shown in (10b).

- (10) a. *Það höfðu virst að vera nokkrir elgir hér.
Ic. there had seemed to be[-FIN] some elk here
- b. *Það höfðu virst ekki vera nokkrir elgir hér.
there had seemed not be[-FIN] some elk here

In Icelandic raising constructions a further argument emerges for our proposal that the complements of raising verbs are ν Ps and not TPs. There appears to be no possibility of partial raising of a derived subject of an unaccusative verb to the subject position of the complement clause (11a). The derived subject can raise partially, but it must be to a position in the matrix clause as shown in (11b) by its position to the left of the matrix participle. We assume this to be the [Spec, Tns] position of the matrix clause (Jonas 1996).

- (11) a. *Það höfðu virst [TP nokkrir elgir [vera <nokkrir elgir> hér]].
Ic. there had seemed some elk be[-FIN] some elk here
(H. Sigurðsson, p.c.)
- b. Það höfðu [TP nokkrirelgir [VP virst [vera <nokkrir elgir> hér]].
there had some elk seemed be[-FIN] some elk here

In Icelandic, an interesting set of facts emerges when we consider non-finite complements of raising verbs that contain a transitive verb.¹ The external argument of the complement clause is forced to raise from its theta-position as in Swedish. However, unlike in Swedish, this raising can

¹ We assume the same facts for unergatives.

be partial, and not necessarily to the highest subject position of the matrix clause. In Icelandic, indefinite subjects can stay lower than matrix subject position but must surface higher than [Spec, vP] What seems clear is that the subject must raise into the matrix clause however, and not to an intermediate subject position in the complement clause. This facts holds for all complement types – unaccusative (12a,b) or transitive (and unergative) (12c).

- (12) a. *Það mundu virðast [TP ýmsir [VP hafa[_{vP} <ýmsir> keypt mörg blóm]]].
 there would seem some.pl. have[-FIN] some.pl bought many flower
 ‘Many people would seem to have bought flowers.’
- b. Það mundu [TP ýmsir [VP virðast [VP hafa [_{vP} <ýmsir> keypt] mörg blóm]]].
 there would some.pl. seem have[-FIN] some.pl bought many flowers
 ‘Many people would seem to have bought flowers.’
- c. *Það mundu virðast [_{vP} stundum [_{vP} ýmsir kaupa blóm]].
 there would seem sometimes some buy flowers.
 ‘Some (men) seem to sometimes buy flowers.’

(H. Sigurðsson, p.c.)

- **Raising in Swedish and Icelandic (up to Merging of finite Tns)**

Based on the arguments given above, we propose that the structure in Icelandic and Swedish of a raising verb with a non-finite complement clause is that shown in (13). The raising verb in Swedish and Icelandic selects a vP or VP complement, but not a TP.

(13)

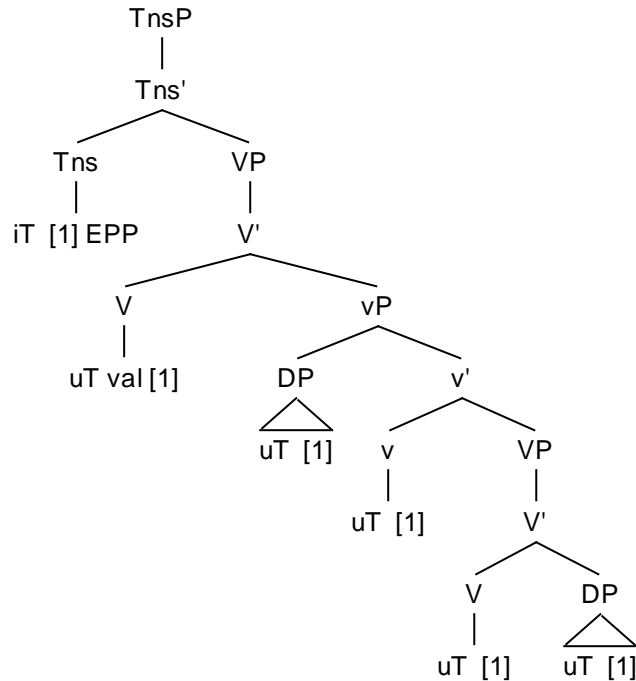

- DP-raising to matrix [Spec, TnsP] is required in Swedish and Icelandic when the complement is transitive.

(14)

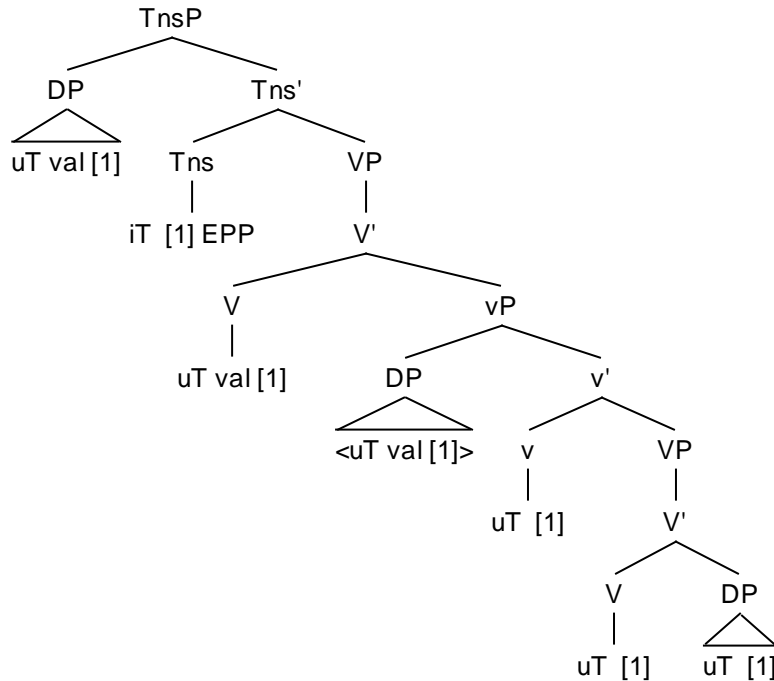

Here we propose that merging an expletive to [Spec, TnsP] is possible just in case the finite verb raises to Tns independent of Verb-Second. This fact holds for Icelandic, but not for Swedish (Vikner 1996, Jonas 1996). Jonas (1996) argues that [Spec, TnsP] is licensed as a derived position for the subject just in case the verb raises to Tns – a fact that holds for Icelandic, but not for the Mainland Scandinavian languages (or English). We argue here that an expletive may be freely merged in matrix [Spec, TnsP] when a subject has raised there, but that a repair strategy is required to correct the resulting multiple specifier construction. We see in (15) the structure that obtains following verb raising to Tense and merge of an expletive in [Spec, TnsP]. Note that we show here the expletive merged in the outer [Spec TnsP] position, however we assume that the multiple specifiers thus created cannot be ordered with respect to each other and the choice of representation of this ordering is completely arbitrary.

(15)

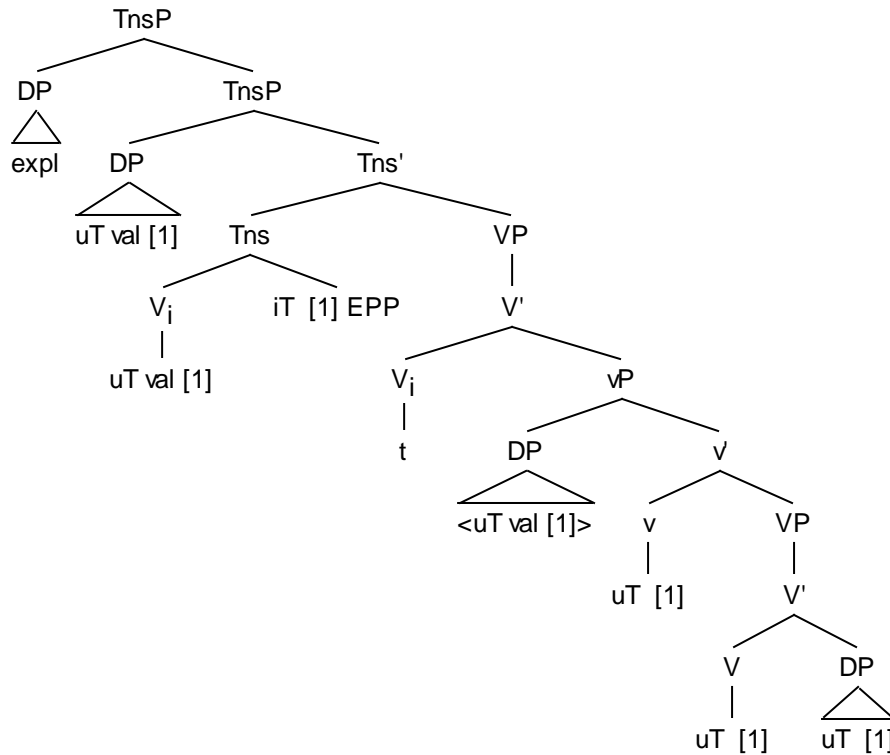

We argue here that multiple specifiers are unlinearizable following the arguments in Jonas & Whitman (2005). What this means is that the structure must be repaired before being sent off to PF. We argue that this is possible when a higher functional head is merged which will attract the expletive. In theory, the subject could be “topicalized” to this position if there is no expletive present (see Holmberg 1993). We assume a functional projection above TnsP and below CP that hosts the expletive and the raised verb in Icelandic and we assume that the specifier of this projection is available just in case the finite verb raises to the head of this projection as part of the head movement chain. The tree in (16) shows the structure that obtains following T to F movement and raising of the expletive to [Spec, FP].

(16)

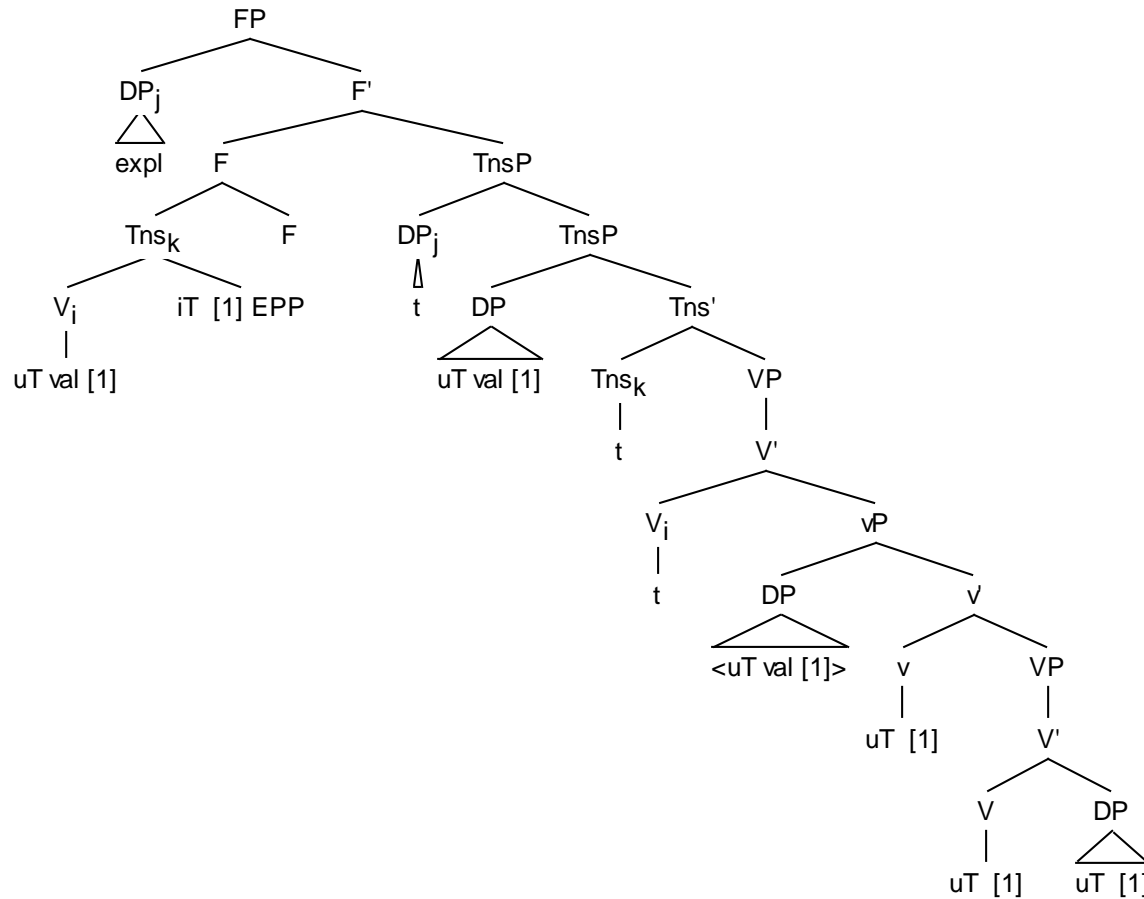

It is possible that this is the beginning of an account of V2. A fronted non-subject first adjoins to TnsP with a subject in it, but linearization is impossible, so an extra projection with the requirement that head and spec both be filled is merged (the V2 requirement), perhaps at PF. English and Swedish do not have V-to-T, so only the subject NP can raise to [Spec, TnsP] or an expletive be merged there blocking raising of the subject to the [Spec, TnsP] position. This might account for the complementary distribution between overt expletives and V2 in Icelandic.

- **Raising in English**

Seem in English selects a TP complement with an infinitival marker present; negation is adjoined to TnsP (17b). The data in (17) show the range of possible raising constructions: Unaccusatives are possible (17a-c). As in Swedish, the external argument of a transitive verb must raise to subject position of the matrix clause and cannot stay low.

- (17) a. There had seemed to be many elk here.
b. There had seemed not to be any problems with this laptop.

- c. There seem to have arisen some problems with our analysis.
- d. *There seem some deer to have eaten the flowers.
- e. Some deer seem to have eaten the flowers.

(18) Raising in English with unaccusative complement clause

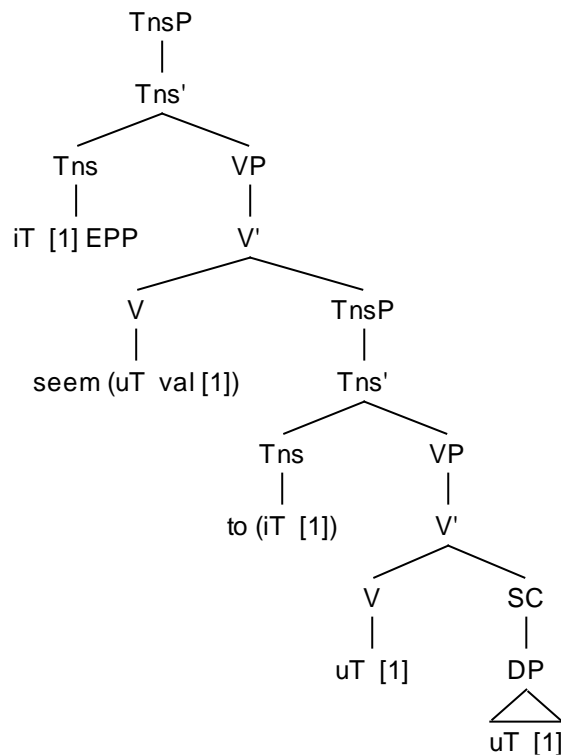

As in Swedish and Icelandic, there is no valuation in the non-finite TnsP. It is the raising verb in the matrix clause that is finite and hence has valued T-feature. Probing by finite Tns creates a link with the feature chain inside the non-finite TnsP. The expletive is merged in [Spec, TnsP] of the non-finite complement clause and is subsequently raised to [Spec, TnsP] of the matrix clause. Thus, merging of an expletive gives the result in (19a). When there is no expletive as in (19b), we get raising of the derived subject.

- (19) a. There seemed to be a man XP.
- b. A man seemed to be XP.

An intermediate subject position is impossible in English as shown in (20). Nevertheless, P&T (2004b:13) propose the raised DP of the lower clause moves through an intermediate specifier position above vP where the DP is Case-marked. Such an analysis is required under a strict phase-based derivation. We do not assume that vP is a phase, at least (Johansson & Jonas, in preparation)

(20) *There seems an elk to be in the forest.

In (21), the structure assumed by P&T with partial raising of the derived subject is given (P&T 2005: 13)

(21)

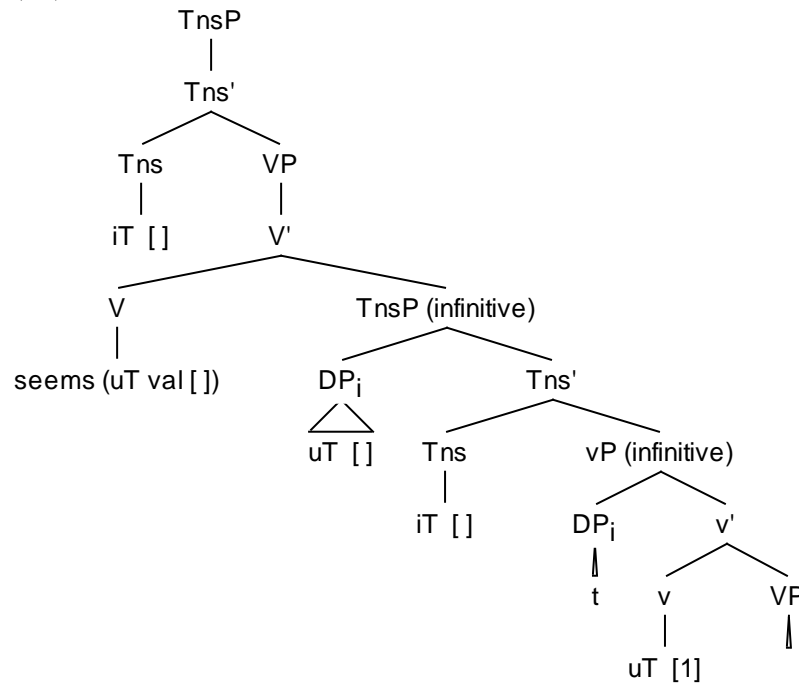

2.2 Passive Constructions

• English Passives

In English passives there is forced partial raising of the derived associate when an expletive is present (22a,b). However the derived subject can only raise to a position immediately to the left of the passive participle and not to a position following the finite auxiliary as is possible in Icelandic.

- (22) a. There have been many elk shot.
 b. *There have been shot many elk.
 c. *There have many elk been shot.

• **Swedish passives**

In passives in Swedish, it is possible for the associate to stay low or partially raise as in English – both options are available. When the subject partially raises the participle appears in an agreeing form (23).

(23) a. Det har blivit många älgar skjutna.
Sw. there have become many elk shot-pl.

b. Det har blivit skjutet många älgar.
there have become shot many elk

A subset of quantified (specific) DPs are preferred in the higher position (24, 25). This includes partitives and negative quantified DPs.

(24) a. Det har blivit tre av älgarna skjutna.
there have become three of elks-the shot.pl.

b. ??Det har blivit skjutet tre av älgarna.
there have become shot three of elks-the

(25) a. Det har blivit inga av älgarna skjutna.
there have become none of elks shot.pl.

b. *Det har blivit skjutet inga av älgarna.
there have become shot none of elks-the

• **Icelandic passives**

In Icelandic passives, there are two positions available for the associate: the lowest position (as in Swedish, but not English), and a higher position following the finite auxiliary, argued to be [Spec, TnsP] in Jonas (1996).

(26) a. Það hafa margir elgir verið skotnir
Ic. there have many elk been shot

b. Það hafa verið skotnir margir elgir
there have been shot many elk

(27)

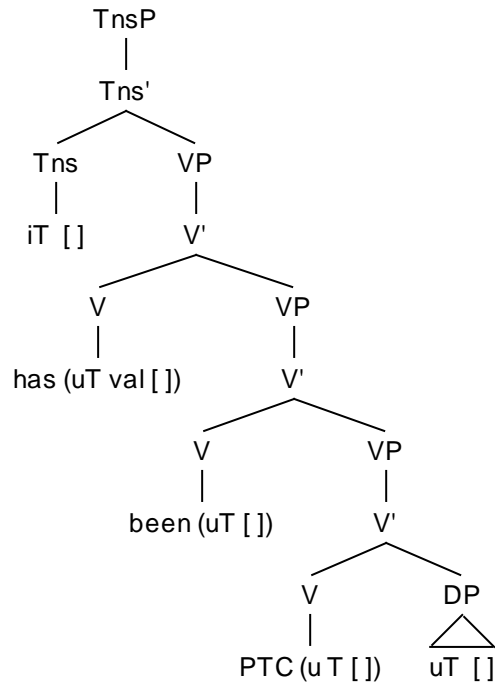

• “Long-distance” Case

The analysis presented here accounts for a set of Icelandic data where the argument of a passive verb stays low but whose morphological case depends on the matrix verb. Here we have a way of accounting for such facts by the availability of long-distance mechanisms of object Case-marking.

- (28) a. Ég tel hafa verið selda margu bíla.
I believe have[-FIN] been sold-A.pl many cars-A.pl
- b. Mér virðast hafa verið seldir margir bílar
me-D seems have[-FIN] been sold-N.pl many cars-N.pl

- in (1) and (2), the case on the thematic object of the lower clause cannot be spelled out or valued until the matrix verb is merged.
- We assume here that both matrix verbs are ECM, *telja* assigns Nominative to its subject, Accusative to the subject of the non-finite complement clause. *Virðast* assigns Dative to its experiencer argument and Nominative (under ECM) to the subject of the non-finite complement clause – ϕ -features are not involved here.

1. After merging V and the object: [_{VP} selda margu bíla]
 - No probing, because, by assumption T on V does not probe.
2. After merging the auxiliaries. We assume that auxiliaries are merged ‘adjoined’ to VP.

[_{VP} hafa verið [_{VP} selda margu bíla]]

- There's no probing, because by assumption only T on *v* probes in the verbal domain.
3. After merging *v*: [_{VP} *v* [_{VP} *hafa verið* [_{VP} *selda marga bíla*]]]
- T on *v* probes the auxiliaries, the lexical verb and the object, creating a 'feature chain', but one that does not have a value.
4. After merging the ECM verb, which we assume takes a *v*P complement:
[_{VP} *tel* [_{VP} *v* [_{VP} *hafa verið* [_{VP} *selda marga bíla*]]]]]
- There's no probing, because T on the ECM verb is valued (this is a finite verb).
5. After merging the subject (which doesn't probe, since phrases don't probe) and finite Tns:
[_{TnsP} Tns [_{VP} *Ég* [_{VP} *tel* [_{VP} *v* [_{VP} *hafa verið* [_{VP} *selda marga bíla*]]]]]]].
- T on Tns probes the subject *Ég*, the lexical verb and *v*. The subject then raises to [spec, TnsP].

In (29), the matrix ECM verb takes an ECM verb as its complement and there is a non-finite complement clause of the embedded ECM verb.

- (29) a. *Ég tel Haraldi virðast þessi hestur vera góður.*
I.N believe H.D seem[-FIN] this horse.N.sg be[-FIN] good.N
- b. *Mér virðist Haraldur telja bílana vera góða.*
me.D seems H.N believe[-FIN] cars.the.A.pl be[-FIN] good

Again, the Case feature cannot be valued and case cannot be spelled out on the DPs in the complement clauses until the finite matrix verb is merged and matrix tense is valued. Once finite Tense is merged, it is valued by the finite matrix verb in (29a,b) and the whole feature chain is valued, the DPs are Case licensed and morphological case spelled out: Nominative on *þessi hestur* in (29a) under ECM by *virðast*, Nominative on *Haraldur* under ECM by *virðast* in (29b); Accusative on *bílana* in (29b) under ECM by *telja*; *Haraldi* in (29a) is spelled out as Dative as the experiencer argument of *virðast*.

Conclusions

- Case assignment is simply valuation of a T-feature on DP, no phi features are involved.
- AGREE can be a one to many relation (c.f. *Multiple Agree* in various guises). Blocking multiple Agree introduces complications in the grammar, and hence is undesirable.
- *v*P is not a phase.
- AGREE "spreads" feature values over multiple positions.
- The morphological realization of valued T on DP as particular Case forms is essentially lexical.

Selected References

- Chomsky, Noam. 1995. *The minimalist program*. Cambridge, Mass.: MIT Press.
- Chomsky, Noam. 2001. Derivation by phase. In *Ken Hale: A life in language*, ed. Michael Kenstowicz, 1-52. Cambridge, MA.: MIT Press.
- Frampton, John, and Sam Gutmann. 2000. Agreement in feature sharing. Ms. Northeastern University.
- Frampton, John, Sam Gutmann, Julie Legate, and Charles Yang. 2000. Remarks on “Derivation by Phase”: Feature valuation, agreement, and intervention. Ms. Northeastern University and MIT.
- Hiraiwa, Ken. 2005. Dimensions of symmetry in syntax: Agreement and clausal architecture. Doctoral Dissertation, MIT.
- Holmberg, Anders. 1993. Two subjects positions in IP in Mainland Scandinavian. *Working Papers in Scandinavian Syntax* 52, 29-41.
- Holmberg, Anders. 2002. Scandinavian stylistic fronting: How any category can become an expletive. *Linguistic Inquiry* 31, 445-484.
- Johansson, Mats, and Dianne Jonas. Late Linearization. Ms. in preparation, Lund University & Yale University.
- Jonas, Dianne. 1996. Clause structure and verb syntax in Scandinavian and English. Doctoral dissertation, Harvard University.
- Jonas, Dianne. In Press. *Clause structure and verb syntax in Scandinavian and English*. New York: Routledge.
- Jonas, Dianne, and John Whitman. 2005. Limiting multiple specifiers at the interface. Ms. Cornell University and Yale University.
- Pesetsky, David, and Esther Torrego. 2004a. Tense, case and the nature of syntactic categories. In *The syntax of time*, ed. by Jaqueline Guéron and Jaqueline Lecarme, 495-538. Cambridge, Mass.: MIT Press.
- Pesetsky, David, and Esther Torrego. 2004b. The syntax of valuation and the interpretability of features. Ms. MIT and UMass Boston.
- Pesetsky, David, and Esther Torrego. 2005. Features, case and syntactic categories. Class handout, Lund University.
- Platzack, Christer. 2006. Case. Some speculations and notations. Ms. Lund University.
- Svenonius, Peter. 2001. Impersonal passives: a phase-based analysis. Arthur Holmer, Jan Olof Svantesson, and Åke Viberg (eds.), *Proceedings of the 18th Scandinavian Conference of Linguistics*. Travaux de l'Institut de Linguistique de Lund. 39.2:109-125
- Travis, Lisa. 1984. Parameters and effects of word order variation. Doctoral dissertation, MIT.
- Vikner, Sten. 1995. *Verb movement and expletive subjects in the Germanic languages*. Oxford: Oxford University Press.

*CGSW 21
2006-04-01*

*UC Santa Cruz
Johansson & Jonas*

Mats Johansson
Center for Languages and Literature
Lund University
mats.johansson@englund.lu.se

Dianne Jonas
Dept. of Linguistics
Yale University
dianne.jonas@yale.edu