



LUND UNIVERSITY

Real-Time Vehicular Channel Emulator for Future Conformance Tests of Wireless ITS Modems

Ghiaasi, Golsa; Vlastaras, Dimitrios; Ashury, Mehdi; Hofer, Markus; Xu, Zhinan; Zemen, Thomas

Published in:
10th European Conference on Antennas and Propagation (EuCAP)

DOI:
[10.1109/EuCAP.2016.7481226](https://doi.org/10.1109/EuCAP.2016.7481226)

2016

[Link to publication](#)

Citation for published version (APA):

Ghiaasi, G., Vlastaras, D., Ashury, M., Hofer, M., Xu, Z., & Zemen, T. (2016). Real-Time Vehicular Channel Emulator for Future Conformance Tests of Wireless ITS Modems. In *10th European Conference on Antennas and Propagation (EuCAP)* (pp. 1-5). IEEE - Institute of Electrical and Electronics Engineers Inc.. <https://doi.org/10.1109/EuCAP.2016.7481226>

Total number of authors:
6

General rights

Unless other specific re-use rights are stated the following general rights apply:
Copyright and moral rights for the publications made accessible in the public portal are retained by the authors and/or other copyright owners and it is a condition of accessing publications that users recognise and abide by the legal requirements associated with these rights.

- Users may download and print one copy of any publication from the public portal for the purpose of private study or research.
- You may not further distribute the material or use it for any profit-making activity or commercial gain
- You may freely distribute the URL identifying the publication in the public portal

Read more about Creative commons licenses: <https://creativecommons.org/licenses/>

Take down policy

If you believe that this document breaches copyright please contact us providing details, and we will remove access to the work immediately and investigate your claim.

LUND UNIVERSITY

PO Box 117
221 00 Lund
+46 46-222 00 00

Real-Time Vehicular Channel Emulator for Future Conformance Tests of Wireless ITS Modems

Golsa Ghiaasi^{*†}, Mehdi Ashury^{*†}, Dimitrios Vlastaras[‡], Markus Hofer[§], Zhinan Xu[§] and Thomas Zemen[§]

^{*}Institute of Telecommunications, TU Wien, Austria

[†]Christian Doppler Laboratory for Wireless Technologies for Sustainable Mobility, Vienna University of Technology, Austria

[‡]Dept. of Electrical and Information Technology, Lund University, Sweden

[§]AIT Austrian Institute of Technology, Austria

email:gghiaasi@nt.tuwien.ac.at

Abstract—In the vehicular communication channels, the mobility of the receiver (RX) and the transmitter (TX) along with the movements of interacting objects in the propagation environment result in significant non-stationary channel fading. The channel impulse response exhibits not just significant delay- and Doppler spreads, but also the delay- and Doppler spreads themselves are changing over the time- and frequency axes. In other words: the channel statistics change as the geometry of RX, TX, and interacting objects evolve over time. To account for this, the local stationary regions in time and frequency are specified and each one is modeled by a distinct local scattering function. We present an architecture for a real-time emulator capable of reproducing the input/output behavior of a non-stationary n -tap wireless vehicular propagation channel. The architecture is implemented as a virtual instrument on LabView and we benchmark the packet error ratio (PER) of a commercial off the shelf (COTS) vehicular IEEE 802.11p modem. The emulator architecture aims at a hardware implementation which features optimised hardware complexity while providing the required flexibility for calculating the non-stationary channel responses by reconfiguring the scattering model for each local stationary region. The National Instrument USRP-Rio 2953R is used as the Software-Defined Radio platform for implementation, however the results and considerations reported are general-purpose and can be applied to other platforms. Finally, we discuss the PER performance of a COTS modem for a vehicular non-stationary channel model derived for highway obstructed line of sight (LOS) scenario in the DRIVEWAY'09 measurement campaign.

I. INTRODUCTION

The imminent launch of 5G applications along with the standardization of intelligent transport system (ITS) communication under IEEE802.11p/WAVE [1], [2] have given rise to a great number of research work aiming at various aspects of understanding, characterization and modelling of the communication channels in vehicle-to-vehicle (V2V) or vehicle-to-infrastructure (V2I) applications [4]–[6]. At the physical layer, there has been a proposal for a set of channel models to parameterize the fading characteristics of the channel in various V2V traffic scenarios [3]. These models are still subject to modification, since some channel model parameters are not defined or require further refinement.

Recent research results [7] indicate that these stationary channel models do not reflect the realistic propagation conditions in safety critical vehicular scenarios. In order to properly

account for Doppler shifts and delays, V2V channels should be characterised by a non-stationary fading process. To be able to simulate such a process, local regions of time and frequency are defined in which the process is assumed to be stationary [20] and can be modeled by means of tapped-delay lines [8]. In terms of computing the channel output, this translates to not only calculating the response of a time varying channel, but also updating these functions while switching among different stationarity regions.

In the development and manufacturing sector, the imminent launch of ITS has encouraged the design and implementation of various modems to be mounted in ITS enabled vehicles. To test and evaluate the performance of these modems, they should be assessed under realistic conditions. Measurement campaigns provide accurate data for the evaluation of modems, but they require extensive planning and resources such as funding, personnel and vehicles, which makes them undesirable for the manufacturers. Alternatively, a channel emulator can be placed between the TX and the RX in order to emulate the fading characteristics of a channel. Such an emulator should be designed to accurately define the joint Doppler-delay spectra by means of proper models. There are several industrial solutions available in the market [9], [10]. They offer reliable solutions for channel emulation, however they are designed on the basis of models derived for cellular applications. In [11], researchers have reported an FPGA-based emulator for vehicular application assuming Ingram-Acosta models [12] which are stationary by definition. To the best of our knowledge, all above lack the accuracy and reconfigurability needed to emulate the fading properties of vehicular channels and no work has been reported on the real-time emulation of models which account for non-stationarity of vehicular channels. In [13] an emulator consisting of two active taps (one LOS and one strong reflector) with equal gains is presented and used for the stress test of vehicular transceivers. This work has served as a starting point for our design.

In this work, we present the design and implementation of an emulator in a software-defined radio (SDR). FPGAs are suitable options which offer flexibility in design process along with shorter time needed for prototyping; however, their finite

resources, such as gate count and clock rate impose limitation on the design of the emulator. Therefore the main challenge is to optimize the trade-off between reconfigurability of the system while keeping the computational complexity as low as possible. The chosen platform is NI USRP-Rio 2953R which operates at frequencies up to 6GHz with 40 MHz bandwidth. It features two MIMO RF chains. It is equipped with a Xilinx Kintex-7 FPGA which is programmable with the NI LabVIEW FPGA Module [18]. The implementation emulates a geometric-based stochastic channel model (GSCM) which accounts for non-stationarities by assuming local stationary regions, and switching between these regions. This work builds on the analysis we presented in [14] of a suitable architecture for such an emulator. We show the experimental results for the real-time emulation of the low complexity non-stationary model reported in [16] of the V2V highway scenario with obstructed LOS measured in DRIVEWAY'09 [19]. This manuscript is organized as follows:

In Section II, we explain the system architecture of the emulator and present two methods to reduce the complexity of the real-time operation. The design of the real-time emulator is presented in Section III. The testbed configuration is explained in Section IV. The summary of the modeled V2V scenario, testbed set up and the experimental results are presented in Section V.

II. EMULATOR ARCHITECTURE

In this section, we present a system-level architecture for the emulator. First we explain the hybrid Host-FPGA structure, subsequently we discuss two system-level techniques which can reduce the computational complexity of our implementation.

A. System Overview

As depicted in Fig.1, the channel emulator consists of three modules: propagation, antenna and convolution. In order to offer the reconfigurability required, these three modules set, calculate and periodically update their specific parameters and pass information to one another through interfaces. The overview of each module's functionality is as follows:

The propagation module gets the specific scenario as input and accordingly sets the global parameters, such as center frequency and sampling rate. Moreover, according to the scenario, this module computes and passes on various parameters associated with each multi-path component (MPC). The examples of these parameters are the attenuation coefficients, path delays and angles of arrival and departure. The Propagation module updates these parameters frequently, so as to account for rapid environmental changes. These parameters do not vary with the same rate, for instance, the pathloss parameters are slow varying compared to parameters associated with the relative position of scatters. We can choose a multi-step update procedure to account for the different rates of variation. In particular, we define two update rates in the propagation module: large scale (LS) and small scale (SS): LS is the rate with which the geometry updates are calculated. It is

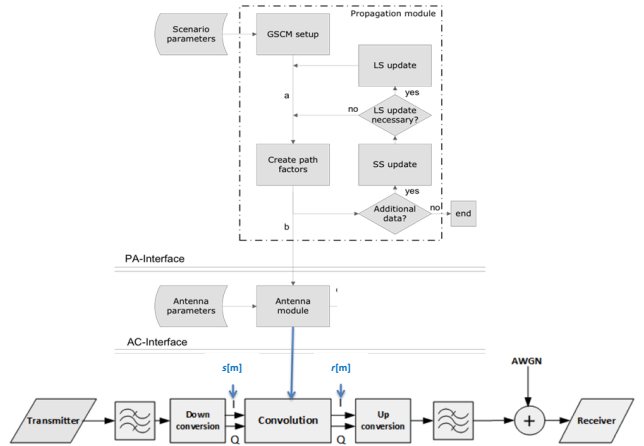

Fig. 1. System-view of the emulator

determined by the stationarity time of the channel which in case of vehicular scenarios equals to 40 ms [7]. Doppler bandwidth determines the SS fading update rate necessary for accurately modeling the Doppler contributions.

In the antenna module, according to the orientation of the antenna (which defines the antenna pattern) the attenuation parameters h_p are calculated for each MPC. These parameters along with the corresponding path delays are passed on to Convolution module through the AC interface. The time-continuous impulse response $h_p(t, \tau)$ is given by (1).

$$h_p(t, \tau) = \sum_{p=1}^P h_p(t) \delta(t - \tau_p) \quad (1)$$

P is the number of the relevant MPCs which have significant received level and $h_p(t)$ represents the attenuation and Doppler shift of p -th MPC.

$$h_p(t) = \eta_p e^{j2\pi\nu_p t} \quad (2)$$

For the purpose of testing the emulator, the two above mentioned modules can be implemented on a host PC and the calculation for each scenario can be performed offline. The results are then stored in a fast memory, which feeds the corresponding parameters to the FPGA.

The convolution module is responsible for real-time calculation of the output stream by convolving the discrete time-varying impulse response of the channel with the input stream according to (3). A more detailed description of the architecture will be given in the following section.

$$r(t) = \int_{-\infty}^{\infty} h(t, t - \tau) s(\tau) d\tau = \sum_{p=1}^P h_p(t) s(t - \tau_p) \quad (3)$$

$$r(mT_s) = \sum_{p=1}^P h_p(mT_s) s(mT_s - \tau_p) \quad (4)$$

B. Complexity Reduction

To accurately compute the vehicular channel models, it is required to evaluate a large number of MPC parameters and to sum them up in real-time. It can easily be observed that the number of relevant propagation paths directly relates to the number of gates needed for the FPGA implementation hence, the complexity reduction focuses on using the minimum value for P which still achieves the accuracy desired for the channel models.

The first method takes advantage of the clustering technique in which the paths with similar properties in terms of delay and Doppler spread are grouped and represented as a cluster [15], [16]; for instance one cluster could represent different points of a single moving object which obviously exhibit similar delay and Doppler spreads. As a direct result of this technique, the number of paths to be emulated is decreased and channel model complexity is reduced significantly.

The second method builds on representing the channel not in the conventional Fourier basis, but in a different subspace which requires fewer multiplications with a complex exponential. An example of such a subspace is spanned by discrete prolate spheroidal (DPS) sequence. In Fact, it is shown that by applying DPS subspace representation, the complexity of the real-time computation is reduced significantly [17].

III. REAL-TIME EMULATOR DESIGN

Since the Convolution is the module which performs the real-time calculation in the FPGA, its architecture is the key to achieving the trade off between complexity and accuracy. The first option is to implement the most general form of convolution by calculation of the discrete version of (4) (shown in (5)). The impulse response coefficients are complex numbers which are given by (2). This architecture is capable of emulating any linear time-varying channel response by simple operations : complex number multiplication and additions.

$$r[m] = \sum_{p=1}^P C_p[m]s[m-p] \quad (5)$$

The drawback is that the rate of update of $C_p s$ is determined by the necessary rate for accurate modelling of $e^{j2\pi\nu_p t}$ elements. This rate is too high to stream to FPGAs in many SDRs.

Alternatively, we chose a tapped-delay line architecture as a suitable candidate: in this architecture the Doppler frequency shifts are implemented in real time, hence reducing the update rate for impulse response samples to LS update rate. The architecture shown in Fig. 2 implements a tapped-delay line with equally spaced taps according to the discrete form of Eq. 4.

$$r[m] = \sum_{p=1}^P \eta_p e^{j2\pi\nu_p t} s[m-p] \quad (6)$$

To keep the gate count of the FPGA in limits, the frequency shift operation and the IQ additions and multiplications should

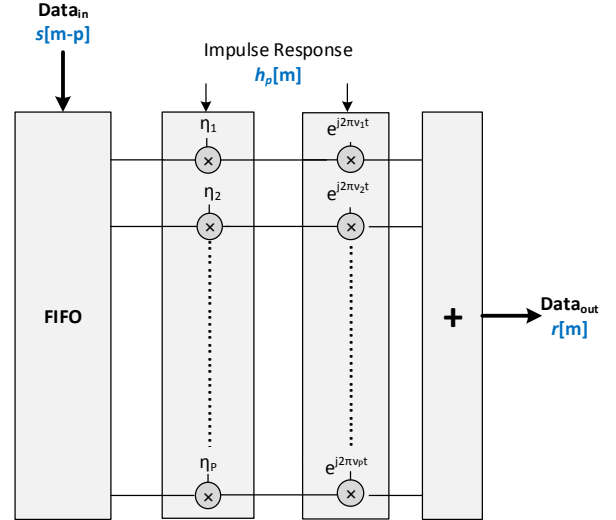

Fig. 2. Tapped-delay architecture

be implemented by a low complexity algorithm. The shortcoming of this configuration is the fact that delays are assumed to fall exactly on the taps, and there is no consideration for representing delays which fall between the taps.

The FPGA was programmed according to Fig. 2. We employed two main FIFOs to stream the input samples $s[m]$, and output samples $r[m]$. The input and output samples are complex numbers relating to I and Q components. The system is designed to have a bandwidth of 20 MHz. In order to cover the contributions of the reflectors which are 1 km away from the transceiver, we have dedicated a total of 68 taps with delay resolution of 50ns from which a maximum of 10 taps may be active simultaneously. The impulse response samples are updated through the Host code and are passed on to the emulator as depicted in Fig. 1.

IV. EMULATOR TESTBED

The testbed consists of a USRP as the emulator connected to a personal computer (PC) running Labview 2014 and two COTS IEEE802.11p modems connected according to Fig.3. The PC fitted with the PCIe interface card is set up as Labview Host which is responsible for loading the compiled bitfiles into the FPGA and configuring several parameters of the RF chains at the beginning of the operation.

The two modems are set up as transmitter (TX) and receiver (RX). The TX is connected to the USRP port RF0 which is configured as a receiver, while the RX is connected to the port RF1 which is configured as a transmitter. There is a 30 dB attenuator placed between the TX modem and RF0 port of the USRP to avoid saturation of subsequent stages. Similarly, there is a 60 dB attenuator placed between the RF1 port of the USRP and the RX modem to avoid an overdrive. The operation is as follows: The IQ data generated by the TX modem is down-converted by the RF0 chain, processed

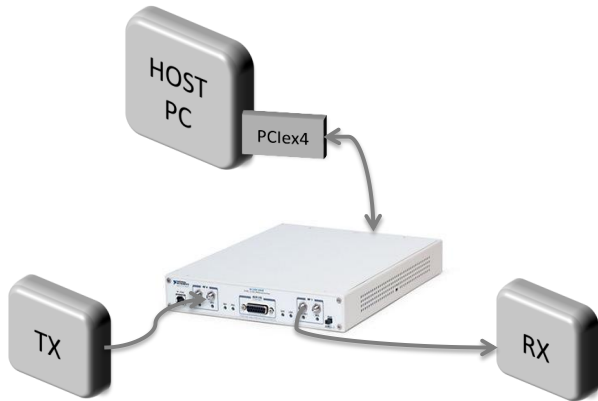

Fig. 3. Testbed set-up

through the FPGA which acts as the channel. Then the signal is again up-converted by the RF1 chain and is received by the the RX modem.

V. MEASUREMENT SETUP AND RESULTS

In this section, we present the test carried out in order to benchmark the performance of two COTS IEEE802.11p modems connected to the SDR which is emulating a non-stationary low-complexity fading model described in [16]. The model we chose relates to the vehicular scenario: highway obstructed line-of sight (LOS) with measured data collected in DRIVEWAY'09 V2V measurement campaign in Lund, Sweden [19]. The duration of the measured scenario is 10 s. As depicted in the general schematics of the scenario in Fig. 4, the TX and the RX drive in the same direction on a highway at around 75 km/h.

The TX drives in front. There is one truck in between the TX and the RX on the same lane which attenuates the LOS component. Additionally, there is a truck driving in front of the TX and along with a car driving by on the left lane. There are two trucks driving in the opposite direction which enter and exist the scenario whose speeds were estimated to be between 70 Km/h. The specific scenario is of particular interest, since not only, similar to other vehicular scenarios, large Doppler and delay spreads are observed, but also the power of the LOS component is similar to the power of the reflected components from various moving objects, hence increasing the impact of their delay and Doppler shift on the performance.

A. Non-stationary Model Parameters

To show the variability of modems' performance while emulating a non-stationary channel, the scenario run time was divided in 4 segments of 2.5 s. Each segment corresponds to a distinct section in the scenario with different characteristics:

In segment 1, there are some cars traveling in the opposite direction which are right in between the TX and the RX. There are also two trucks driving in the opposite direction

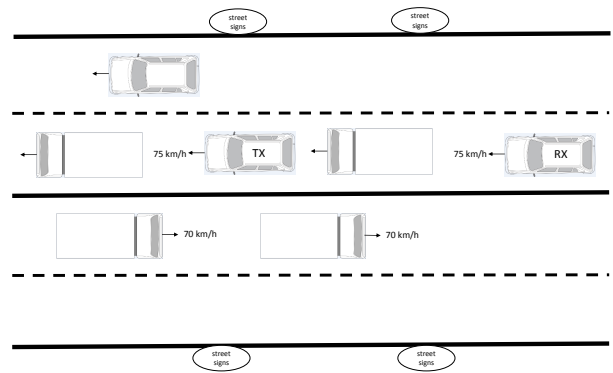

Fig. 4. Vehicular scenario: highway obstructed LOS

and leaving the TX and the RX. In segments 2 and 3, the two trucks keep travelling in the opposite direction, increasing their distance with the TX and the RX. In segment 4, the two trucks in the opposite lane have left the scenario. We only see contributions from objects driving in the same direction as the TX and the RX.

The measured data collected in each of these segments were analyzed according to [16]. For each segment, the probability density functions for cluster birth rate, cluster location in the delay-Doppler plane, cluster lifetime and the power amplitude of the cluster were generated. Then, for each of the four segments, a single random realization containing 250 snapshots with a duration 40 ms duration was generated. Each snapshot contains the information on the present clusters with their corresponding delay, power amplitude and Doppler shift.

B. Measurement setup

Two COTS 802.11p modems configured as the TX and the RX were connected as described in Fig. 3 to the SDR device. When the channel emulator bitfile is loaded in the USRP device and the emulator is ready, the TX modem starts sending the specified number of packets with specified payload. At the RX, we get the number of correctly decoded packets which is then used for the calculation of PER. Table I summerizes the parameter values used for configuring the transmission and reception of packets. Alreday saved in the PC, the channel model parameters for each segment realization are loaded in the emulator and automatically updated every 40ms from the Host code. The parameters of all snapshots relating to each segment take 10 s ($250 \times 40\text{ms}$) to get fed into the emulator, this duration may not be enough for calculation of average PER with typical values for payload and data rate. To overcome this, we repeat the set of paramters till the packets are fully received. The PER is recoreded for the RX average power value around -65 dBm for each segment. The resultant PER for diffrent segments are shown in Fig. 5.

C. Measurement results

In the segment 1, the clusters detected due to the contribution of the nearby cars locate very close to the position of the LOS component, also the contribution from the two trucks

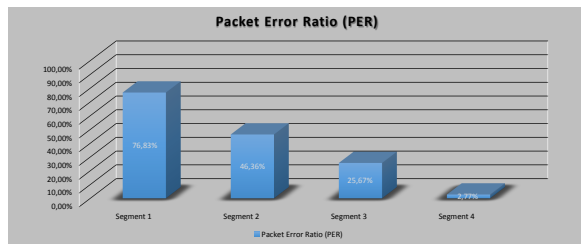

Fig. 5. Measured PER

driving in the opposite direction is at high Doppler frequency (around -1500Hz), therefore increasing the delay and Doppler spreads for this segment. This leads to a high PER for this segment. In the segments 2 and 3, there is an increasing delay resulting in a large delay spread due to contributions from the two trucks in the opposite direction, however the Doppler spread does not increase, since the relative speed is not changed significantly. In the segment 4, we observe a very low PER. This is due to the fact that only contributions from the car and the trucks in the same direction exist hence, leading to small and steady delay and Doppler spreads, while contributions from the trucks in the opposite direction have faded.

TABLE I
MEASUREMENT SET UP PARAMETERS

Measurement parameter	Value
Frequency channel	180 (5.9 GHz)
Packet length	1000 Bytes
Number of packets (=frames) in one burst	10000
Burst repetitions	1
Average RX power	-65 dBm
Power level at channel emulator input	-30 dBm
Data rate	6 Mbps
Baseband modulation	BPSK
Coding rate	1/2

VI. CONCLUSION

In this work, the design and prototypical implementation of a real-time FPGA-based channel emulator for benchmarking vehicular modems is investigated. The design allows to emulate both *stationary* and *non-stationary* channels in vehicular environments. Several techniques in system- and circuit-level implementation are employed to limit the design complexity while keeping control on the emulator's accuracy.

A vehicular COTS modem was benchmarked as follows: two identical COTS modems are used: one for packet transmission and the other for reception. Transmitter and receiver are connected via coaxial cables to the channel emulator. The COTS modem's packet error ratio (PER) is measured at the average received power -65dBm for the channel model

parameters of the four distinct segments of the highway LOS obstruction as described in Section V-A. Our results show the varying PER for different segments of the scenario. They also confirm the that large Doppler and delay spreads caused by objects traveling with relatively high speed at the opposite direction degrades the performance significantly.

ACKNOWLEDGMENTS

This work was performed with support by the Christian Doppler Laboratory for Wireless Technologies for Sustainable Mobility.

REFERENCES

- [1] IEEE Std. 802.11p-2010, Part 11: Wireless LAN Medium Access Control (MAC) and Physical Layer (PHY) specifications: Amendment 7: Wireless Access in Vehicular Environment, IEEE Std., July 2010.
- [2] "ETSI TR 102 638 - intelligent transportation systems (ITS); vehicular communications; basic set of applications; definitions," ETSI, Tech.
- [3] P. Alexander, F. Tufvesson and M. Nilsson, "G5 Radio Channel Models (Version 4)", Car-2-Car Communication Consortium, Architecture Meeting Ulm, Germany, Sep. 2013.
- [4] T. Abbas, L. Bernardo, A. Thiel, C. Mecklenbrauke and F. Tufvesson, "Radio Channel Properties for Vehicular Communication: Merging Lanes Versus Urban Intersections," Vehicular Technology Magazine, IEEE, vol.8, no.4, pp.27,34, Dec. 2013.
- [5] A. Paier, C. Karedal, N. Czink, C. Dumard, T. Zemen, F. Tufvesson, A.F. Molisch and C. Mecklenbräuker, "Characterization of vehicle-to-vehicle radio channels from measurements at 5.2 GHz," Wireless Personal Communications, 2008.
- [6] C. Mecklenbrauker, A.F. Molisch, J. Karedal, F. Tufvesson, A. Paier, L. Bernardo, T. Zemen, O. Klomp and N. Czink, "Vehicular channel characterization and its implications for wireless system design and performance," Proceedings of the IEEE, vol.99, no.7, pp.1189,1212, July 2011.
- [7] L. Bernardo, T. Zemen, F. Tufvesson, A.F. Molisch and C. Mecklenbräuker, "Delay and doppler spreads of non-stationary vehicular channels for safety relevant scenarios," IEEE Transactions on Vehicular Technology, vol. 63, no. 1, pp. 82–93, 2014.
- [8] A. F. Molisch, F. Tufvesson, J. Karedal and C. Mecklenbrauker, "A survey on vehicle-to-vehicle propagation channels," IEEE Wireless Communications Magazine, vol. 16, no. 6, pp. 12-22, December 2009.
- [9] PropSim channel emulation solutions, <http://www.anite.com/>
- [10] Spirent Communications, July 2009, <http://www.spirent.com>
- [11] T.M. Fernandez-Carames, M. Gonzalez-Lopez and L. Castedo, "FPGA-based vehicular channel emulator for evaluation of IEEE 802.11p transceivers," 9th International Conference on Intelligent Transport Systems Telecommunications, (ITST), Oct. 2009
- [12] G. Acosta-Marum and M. A. Ingram, "Six time- and frequency-selective empirical channel models for vehicular wireless LANs," in Proceedings of VTC Fall, Baltimore, USA, Oct. 2007.
- [13] D. Vlastaras, S. Malkowsky and F. Tufvesson, "Stress Test Of Vehicular Communication Transceivers Using Software Defined Radio," 81st Vehicular Technology Conference, 2015.
- [14] G. Ghiaasi, C. Mecklenbräuker and T. Zemen, "Architecture of Real-Time Vehicular Channel Emulator", presented in COST IC1004 TD(15)13040, Valencia, Spain, May 2015.
- [15] Z. Xu, M. Gan, C. Mecklenbrauker, T. Zemen, "Cluster spreads for time-variant vehicular channels", in 9th European Conference on Antennas and Propagation (EuCAP), Lisbon, Portugal, April 2015.
- [16] Z. Xu, M. Gan and T. Zemen, "Cluster-Based Non-Stationary Vehicular Channel Model," EuCAP 2016.
- [17] F. Kaltenberger, T. Zemen, and C. Ueberhuber, "Low-complexity geometry based MIMO channel emulation," EURASIP Journal on Advances in Signal Processing, 2007.
- [18] NI USRP-2953R, <http://sine.ni.com/nips/cds/view/pl/lang/en/nid/213005>
- [19] A. Paier, L. Bernardo, J. Karedal, O. Klomp, and A. Kwoczek, "Overview of vehicle-to-vehicle radio channel measurements for collision avoidance applications," IEEE 71st Veh. Technol. Conf., 2010.
- [20] G. Matz, "On non-WSSUS wireless fading channels," IEEE Trans. Wireless Commun., vol. 4, no. 5, pp. 2465–2478, September 2005.