



LUND UNIVERSITY

Differentiated limits for knowability

Bierschenk, Bernhard

2005

[Link to publication](#)

Citation for published version (APA):

Bierschenk, B. (2005). *Differentiated limits for knowability*. (Kognitionsvetenskaplig forskning / Cognitive Science Research; Vol. 97). Copenhagen University & Lund University. <http://archive.org/details/studiesinconsciousness>

Total number of authors:

1

General rights

Unless other specific re-use rights are stated the following general rights apply:

Copyright and moral rights for the publications made accessible in the public portal are retained by the authors and/or other copyright owners and it is a condition of accessing publications that users recognise and abide by the legal requirements associated with these rights.

- Users may download and print one copy of any publication from the public portal for the purpose of private study or research.
- You may not further distribute the material or use it for any profit-making activity or commercial gain
- You may freely distribute the URL identifying the publication in the public portal

Read more about Creative commons licenses: <https://creativecommons.org/licenses/>

Take down policy

If you believe that this document breaches copyright please contact us providing details, and we will remove access to the work immediately and investigate your claim.

LUND UNIVERSITY

PO Box 117
221 00 Lund
+46 46-222 00 00

ISSN 0281-9864

Differentiated Limits for Knowability

Bernhard Bierschenk

2005

No. 97



Copenhagen University
Denmark



Lund University
Sweden

**KOGNITIONSVETENSKAPLIG
FORSKNING**

Cognitive Science Research

Differentiated Limits for Knowability**Bernhard Bierschenk****2005****No. 97****Cognitive Science Research**

Lund University
University of Copenhagen

Editorial board

Bernhard Bierschenk (editor), Lund University
Inger Bierschenk (co-editor), University of Copenhagen
Ole Elstrup Rasmussen, University of Copenhagen
Helge Helmersson (adm. editor), Lund University
Jørgen Aage Jensen, Danish University of Education

Cognitive Science Research

Copenhagen Competence
Research Center
University of Copenhagen
Njalsgade 88
DK-2300 Copenhagen S
Denmark

Adm. editor

Helge Helmersson
Dep. of Business Adm.
Lund University
P.O. Box 7080
S-220 07 Lund
Sweden

Abstract

The present article has been based on the string-hypothesis, which has important scientific consequences. Today, understanding of measurement and representation means to assign a number. Science in the statistical age of the 20th century has meant to associate the notion of number with the strict operation of counting. However, recent account of string-theoretical approaches and functional geometry, rediscovered by the space science, is sharply distinguishing “number” from “magnitude”. In studying “spinning” strings in the context of evolutionary language dynamics, it is shown that string-rotation is a valid concept for the observation of different thermodynamic limits. For the description of rotating strings, super strings and super symmetries, fitness values have been produced during the generation of corresponding energy landscapes. Their significance has been founded on the hypothesis that distance is a function of rotational acceleration and that spinors have the capacity to carry rotating string composites of varying complexity. Finally, it has been made evident that the phase transition of a string from its virtual to its material state results in a super-fluid solid, which means that dissipation-less flows of kinetic energy is decreasing the symmetry of a string. Since spinors are controlling the flow, breaking the symmetry of a string allow for the establishment of dimensional asymmetries. As a result, the asymmetry of the dimensions of intention and orientation has been determined and their componential disparity has been made manifest in the global singularities of the underlying fitness landscapes.

Manifestation of Reading-Writing Styles in Energy Landscapes

With special emphasis on hyperbolic space properties, the manifestation of style through energy landscapes connects to current trends and developments in the study of complex systems, non-linear dynamics, self-organisation and -reference. The study of how a reading-writing style becomes evident as well as invariant refers to lawful variable-relations. Variables must build up and become manifest within the context of continuously developing language spaces. Their foundation on the Agent-action-Objective (AaO) axiom provides evidence for the emergence of [AaO] systems as well as for variables, which have the capacity to grow in complexity. Moreover, text develops evolutionary, which means that text cannot exist in latent form in the brain. Text must evolve and embody structural AaO-relations. These are approachable with VERTEX, which offers the means for a description of open AaO-spheres through angular articulations and attitude change in the mathematical sense. Since the clocking mode of the discovered mechanism solves language equations, their solutions must fall out within the context of natural language systems. These systems contain their own intrinsic coordinates and exhibit periodic behaviour. But the coordinate-free and consequently invariant description of their A-O-kinematics refers to the establishment of energy landscapes through which reading-writing styles can emerge and be abstracted.

The main hypothesis of the present approach is founded on the assumption that the processes of reading and writing are changing bio-kinetic energy, fused into the produced strings of graphemes. Resulting invariants acquire their characterising properties through bio-kinematic transformations. Since the Agent-action-Objective (AaO) axiom offers a basis for the depiction of strings of graphemes as well as their movement patterns, it has been possible to demonstrate that derived [AaO] systems carry intention and contain cues to the producer's orientation. Crucial for the specification of the operating transformations has been to establish a link between the invariants of reading and writing and a produced style. Furthermore, to catch the fundamental implications of the string-concept in the context of evolutionary language dynamics, string movements have to be observed at the textual level. It follows that complex systems and nonlinear dynamics constitute the new condition, which is founded on the assumption that:

- (1) Self-sensitivity is related to lawful regularities in string movement.
- (2) Local symmetries specify semantic-free patterns of strings.
- (3) Phase-dependent displacements of strings are producing open spheres.

In confining the production of open spheres to the working of two clocks, namely the A-clock, governing the rhythmic movements of in the Agent-component of the AaO-paradigm, and the O-clock, governing corresponding movements in the Objective-component, wholeness and order can be apprehended. Thereby, it is made obvious that text production implies displacement through rhythmic movement patterns, which can be measured with precision. In using phase-dependent displacements of strings of graphemes, it is possible to determine the rhythmic, clock-like working mode of text building behaviour in the study of synthesising processes.

Previous studies have shown that the biological coordination of the A- with the O-component is absolute and established on the basis of a process that is independent of the material (grapheme) composition of these components. But it is expected that a reanalysis of the established spaces, shown in I. Bierschenk (2005) and B. Bierschenk (2005), will allow for a refined treatment of relative coordination and thermodynamic specification as well as an extended discussion of the involved transformations of stored energy.

Geometric Foundation

The essential property of the fundamental string-dimensions is founded on strings, which carry stored energy. Relative coordination and preservation of the “clocking” of a string is resulting from the energy, invested during reading and writing. In text production, topological consequences of rhythmic string movements can be extracted from the precision in the working of the involved clocks. Rhythmic driving forces and cyclic returns constitute the comprehensive basis for self-reference. More or less regularly repeating cycles have been shown to develop on the principle of cooperative interaction between “proprio-specific” and “extero-specific processes.

Regularity can be determined through the production of strings of graphemes, which appears in the presence of a small kinetic potential (v_p). Since the potential of a string represents the energy, needed to produce a signal (σ_i) of “intent”, a signal is controlled by the stepping function (i), which governs the folding of intention. As shown in Figure 1, the materialisation of the core of a vertex appears in the presence of a folded kinetic potential (v_p), which is producing a string-vector. The angle represents the magnitude of the vector (Hestenes, 1986/1993, pp. 66-68). When related to the A-component, the angle (ϕ) applies. The other reference in Figure 1 concerns the O-component, which implies the angle (θ). The tilt of a particular vector is [$\arccos(\phi, \theta) = 2\pi/360^\circ$]. In sum, when a potential becomes materialised, it lowers the “short-distance sensitivity” (Greene, 1999, p. 146) of a string-vector.

Figure 1.

Kinetic Potential of a Grapheme-string (g)

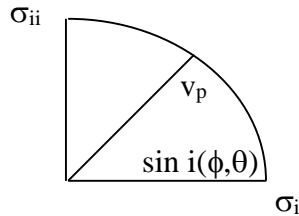

Note: Area of the Identity-sheet / Arc length = $|A| = |O| = 0$.

A magnitude of a grapheme string (g) is just twice the directed area of the circular sector between two vectors. The relation is determined by the simple proportion of an “area of a sector”, when put in relation to its “arc length” ($\pi i/2\pi$). Since the circumference of a circle is proportional to its radius (Greene, 1999, p. 238), the relation can be used thermodynamically in the determination of the degree to which the vector (σ_i) can wrap vector (v_p) through winding.

The “kinetic uniqueness” of a ($v_p \wedge \sigma_i$) compound is always expressed as the wrapped string, but an unwrapped string implies at the same time a relaxed state. Strings, in relaxed states appear as non- g , except as placeholders (\emptyset), which have the function of dummies. Thus, distance-sensitive strings ($\Delta\sigma_i$) are producing a spectrum for the expression of the bi-directional grapheme-vector ($v_p \wedge \sigma_i$), and a symmetric scalar, which leads to the compound [$g_i = (v_p \bullet \sigma_i)$]. Hence, the “outer product” (\wedge) provides a unique relationship of a two-dimensional sheet, which is representing a directed plane-segment (Hestenes, 1986/1993, pp.

66-68), The bi-vector part of Figure 1 constitutes the foundation for the “**g**-spinor”, while the scalar is an efficient expression for generated graphemes. Consequently, (**g**) is the outcome of an orthogonal as well as a perpendicular relation between a potential and a signal of intent.

If a **g**-spinor has been indexed with the scalar ($\lambda=1$) and has the defined orientation (**o**), (**g**) may be conceived of as a multi-vector with a positive orientation. In the reformulation of a grapheme, the scalar can be used due to its special algebraic property. Pre-multiplying the vector (**o**) with the scalar (λ) implies the relation ($\mathbf{g}=\lambda\wedge\mathbf{o}=1$). By this measure it is possible to associate a certain magnitude with the orientation in (**g**). Following up this operation implies a spinor, which takes the relation ($\mathbf{g}=1$). Thus far, the **g**-spinor is of unit length. Moreover, representing intention (**i**) requires a new spinor. Pre-multiplying the **g**-spinor with the vector (**i**) results in the directional spinor ($\delta=i\mathbf{g}$).

This measure generates the intentional dynamics of a verbal flow-field. In the geometric reformulation of the presence of a grapheme, this property is used with the purpose to transform a grapheme into a mono-layered composite. With flow-fields as intermediaries, field variables like placeholders (\emptyset), present the condition for an indirect interaction between string-vectors. Thus, local compounds are “spinor-valued” (Hestenes, 1994a, p. 67) state functions. Therefore, compounds are consistent with the properties of physical space. By the previously presented measure of length, all fields have been identified. Length is dependent on how time is approached. In taking space and time into account, their interdependency becomes defined operationally, which means that they are relative concepts. Moreover, it has also been shown that the achieved results are independent of the employed AaO-procedures.

Fundamental String Dimensions

First and foremost, when a grapheme resonates, a particular string gets its orientation. When interacting strings are conceived of as variables, a physical time scale is definable. Consequently, on the basis of moving α - and β -variables, the time interval or arc length is defined as the clocking mode of the AaO-mechanism. Thus, with reference to the “spacetime” concept, spinors have a differential function. For example, a counter-clockwise rotation of the orthonormal vectors (**i**) and (**o**) is producing an orbit on a completely symmetric sphere, whose outer product ($\mathbf{i}\wedge\mathbf{o}$) is a specification of the position space of a string (σ_i). As shown in Figure 2, inasmuch as the α -composite of the A-component and the β -composite of the O-component are treated as autonomous surface generators, it is possible to determine each composite as a variable.

Figure 2.

The Composite of a Textured Surface Layout

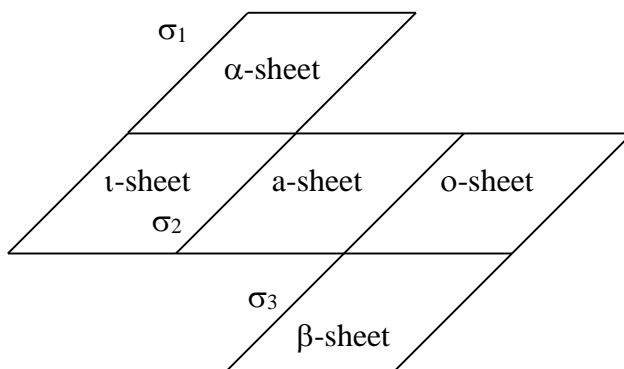

In the position space of $(\sigma_1, \sigma_2, \sigma_3)$, clocking is related to the measure of distance. Hence, strings, which perform the rotational function, can be identified with the units of timing. The spacetime product gives expression to timing and spacing as well as to multiplicative factoring.

When the scalar of the grapheme-vector ($v_p \wedge \sigma_i$) satisfies the expression ($i \wedge g = 1$), it is the generator of some rotational velocity. Especially the expression of supplementation [$S = i(g)$] is producing an intentional transformation. This is a kind of transformation, which is responsible for a continuously available flow of energy. Thus, the developing curvatures of the A-component give appearance to an ordered sequence of grapheme positions that is expected to differ from the developing curvatures of the sequencing order of the grapheme positions of the O-component.

The concept of biological time implicates directed-ness (δ). For example, when the (a)-component of the [AaO] systems gives expression to the relation ($\delta \neq 0$), textured surfaces come into existence and sheets become measurable. In particular, when the condition of ($\delta = 0$) applies it permits the AaO-mechanism to calculate a rotational step of zero length. With reference to Figure 1, the directed area of a α -sheet is given in the relation ($A = \frac{1}{2} \delta \wedge \alpha$) while the corresponding area of a β -sheet is captured in the relation ($O = \frac{1}{2} \delta \wedge \beta$). To determine the change in the position of a certain sheet, a counter-clockwise move through the entire flow-field is demonstrable on the basis of produced variables.

Thus, the δ -spinor is involved in the expression of a cycle as a whole. If this spinor has been determined as ($\delta \wedge \alpha = 0$), it means that the flow is boundless. However, if ($\delta \wedge \alpha \neq 0$), it can be concluded that at least either a α -variable or a β -variable has become manifest. According to Figure 3, rotation in a variable is determining the minimum of state change in a component.

Figure 3.

Rotations with Radian Measures ($2\pi/4 = \pi/2$) in the AaO-Components

Area of the A-Texture / Arc length Area of the o-Texture / Arc length

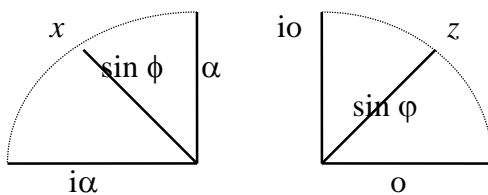

Area of the O-Texture / Arc length Area of the ι-Texture / Arc length

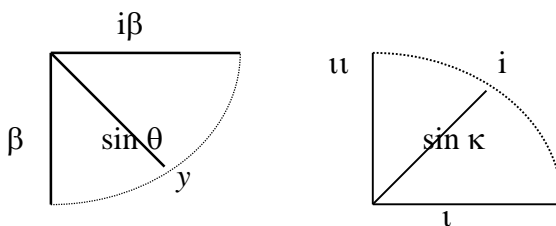

Another important function of the rotation dynamics of the AaO-mechanism is its capacity to track displacements of textual elements. It follows that the mechanism has the capacity of

updating the impact of the scalar (ι). This is the necessary component, which previously has been described as stepping. To repeat, the process implies the pre-multiplication of the α -vector of the A-component and the β -vector of the O-component with the δ -spinor. It follows that the angles of a directed area of a sheet of texture represents the magnitude of winding in a variable. Hence, variables are represented through the magnitudes of certain spinors.

In the production of the textured language space, variables become realised at the moment, when a verbal flow is transformed into writing. But expressing something in natural language implies also the appearance of placeholders. Since any phase transition results in a decrease of symmetry and, since Hestenes' (1986/1993) spinor mathematics offers a notation that can control broken symmetries, spinors have been used to establish prismatic textual surfaces and to represent graphemes as directed surface segments. Hence, a phase transition from non-g to (g) transforms into "a superfluid solid and flow" (Hurtley & Szuromi, 2004). At the kinetic level of text production, a flow of (v_p) is generating flow-fields in which produced strings (σ_i) reverberate and become persistent. The significance of the participating spinors is founded on the hypothesis that distance is a function of rotational acceleration and that "g-spinors" have the capacity to carry text segment as composites of varying complexity.

Basically, all non-g are absolutely identical. Conceptual differences between the function of a string and the expression of a grapheme arise when differently materialised graphemes are conceived of as different "grades" on (σ_i). But the relation between grades and the individual grapheme needs also to be addressed. When related to g-variety and variability, grades concern the dependency of composites on their textual context. It follows that the variability of graphemes refers to individual developments, which become manifest through differences in a composite. Hence, development appears in the form of textual surface properties, which are observable as information carrying sheets of texture.

As it appears in Figure 4, the biological mechanism has the capacity to get hold of intentionality and orientation.

Figure 4.

Energy Flow through the AaO-sphere

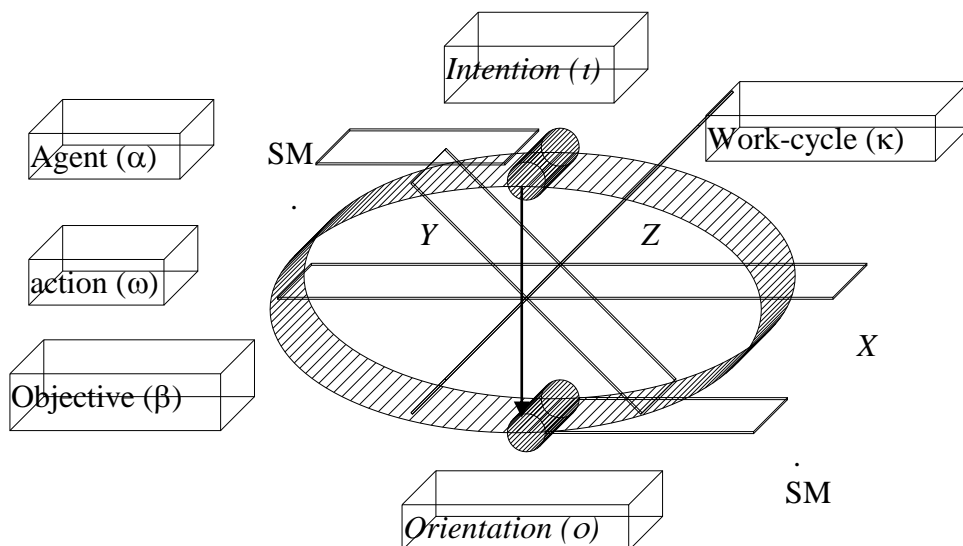

However, for manifesting the working of the algorithm, the effect of invested kinetic energy on dynamic patterning has to be made evident. As a first measure, it is important to observe the development of a configuration of channels. A successful reconstruction of a channelling configuration builds on the regeneration of the ways in which a certain (A) in relation to its (O) component contributes to the production and reconstruction of the symmetry of a particular AaO-unit. The following relation $((A \bullet O \bullet a) |X| |Y| |Z| \cos \theta, \phi)$ shapes the precondition.

Within the imagined openness, related strings give expression to the three-dimensional arrangement $((A \wedge O) \wedge a)$, which is the torus (T^1). This is a new kind of directed numbers and is called a trivector of dimension one (Winfrey, 1980, pp. 4-6). Since the outer product $(\iota \wedge o)$ relates orthogonally, (ι) and (o) stand in perpendicular relation to one another. Hence, the inner product $(\iota \bullet o = 0)$ is an efficient expression of this condition. Within the imagined AaO-sphere, the order of multiplication determines the “intentional orientation” in the production of variables. Biologically conceived, directedness relates to the order of a sequence of variables.

Algorithmic Processing

Processing a flow (v_p) must begin at the second marker of a sentence (SM). It follows that the algorithm has to work its way upward and through particular flow-fields. Thus, the initialising signal (σ_i) is always occurring at the second SM. Taken as a measure of produced and processed potentials, dressing the graphemes of the (a)-component has been indicated with the scalar (ω) . A negative match, in the search between two (SM) or between two clause markers (CM) and a grapheme registered in the dictionary (Ω) , is therefore returned as $(\omega=0)$. Moreover, when the α -vector of the A-component and the β -vector of the O-component are pre-multiplied with a zero scalar, they have to be regarded as spinors of zero magnitude. This is expressed by formulating the relation $(\omega\alpha=0, \omega\beta=0)$ or by writing simply the equation $(\alpha=\beta=0)$. At the moment when the algorithm has reached the beginning of a sentence, which is marked with a technical (TSM) in case a natural (SM) is missing, processing of the involved work-cycles (κ_i) is complete. As shown in Figure 5, the geometrical expression of displaced strings of graphemes is of particular import to the working of the AaO-mechanism, since it is saying that the degree of rotation of a string on a strand is describing the directionality of a volume-flow.

Figure 5.

Degrees of Strand-rotation

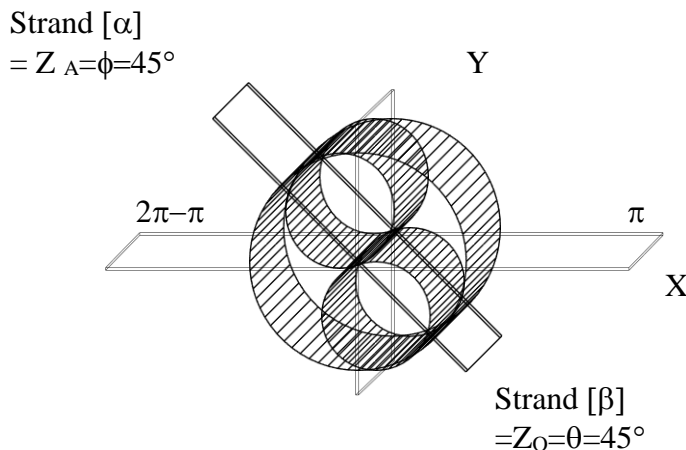

The necessity of this kind of processing has been determined empirically. Thereby, the AaO-mechanism is steadily producing new forms of sequences of variables. Obviously, variables become displaced, which means that the production of graphemes must encompass the concept of “heterochronic processing” (Bierschenk & Bierschenk, 2004). Through dislocating strings of graphemes positional, new variables are establishing itself as a result of novel terminal states.

The magnitude of a complete cycle can be equated with the concept of wholeness, which in geometric terms means a spin. In short, $[A\emptyset=-1\text{spin}]$ and $[O\emptyset=-1\text{spin}]$ are orthogonally related and the α - and β -strands are standing in perpendicular relation to each other. To be complete, each strand must express the carrying or non-carrying of a certain distance-sensitive string ($\Delta\sigma_i$). This corresponds very naturally to the computation of different kinds of “spin-values” and consequently discontinuities.

String-vectors, which rotate on (α) are equal to $(e^{i\phi/2})$, where $(e^{i\phi/2}=\cos\phi+i\sin\phi)$, while string-vectors, rotating on (β), are equal to $(e^{i\theta/2})$, where $(e^{i\theta/2}=\cos\theta+i\sin\theta)$. String-rotation through the alpha-angle, followed or preceded by a rotation through the beta-angle is equivalent to a strand-rotation through the angle $[i\theta+\phi]$. Similarly, the rotation through two right angles, measured by (π) is reversing the direction. It follows that the relation becomes $[\log(-1)=i\pi=e^{i\pi}=-1]$. The positive root of this expression gives finally $[\theta=1/2\theta, \phi=1/2\phi]$.

Thus, the non-zero value of the scalar parameter (ω) determines the unique three-dimensional segment of a strand. If the displacement of the tri-vector fails in the direction of (δ), sweeping out the four-dimensional space-segment ($T^1=\alpha\wedge\beta\wedge a$) has likewise failed. This condition can be expressed by writing the outcome in the form of the following relation $((\alpha\wedge\beta\wedge a)\wedge t=(\alpha\wedge\beta\wedge a \wedge t=0)$.

By reconsidering the edges of (ω), it becomes obvious that (ω) performs also the function of a joint. Joining implicates integrated cycles. Furthermore, their function is to allow for the displacement of variables over several flow-fields. A definite outcome entails always ($\omega=1$). Most typically of the directed processing of a variable is the case, where the AaO-mechanism detects variables between (SM) and (ω)-specific expressions. Thus, the spinors define a flow-field as well as the rotational distance between variables.

The introduced dummies ($A\emptyset$) and ($O\emptyset$), have been of value in redefining (-1spin) with variables of zero charge. In automatic processing, this is equivalent with saying that the cyclic return is of (k_i) steps. When there is no return to any of the (A) or (O) components, the value is ($k_i=0$). But all positive matches with the graphemes in (Ω) are signals of intent. It is typical of the processing of ($k_i>1$) that the dummy (\emptyset) is assigned in case of missing α - or β -variables. This is expressed by the relations ($\omega=|\omega|$), where ($\omega=1$) and $0=X=Y$.

Since any time-varying rotation on the Z-dimension of Figure 5 can be expressed as spinor-valued function of time, stepping through and returning in cyclic manner to (A) and (O) respectively is the significant achievement. Moreover, directedness within a flow-field is expressed functionally, when the intentional vector (t) comes into action. As mentioned previously, by pre-multiplying ($\omega=1$) with the vector, a directed bi-vector comes into existence, which is of certain length. By letting the AaO-mechanism calculate an expression as a function of bi-vectors and vectors, finite displacements of string-vectors as segments of a strand can be analysed, since both the inner (\bullet) and outer (\wedge) products are measures of relative directedness and complements of one another.

A counter-clockwise rotation is involved in the displacement of a string-vector. Displaced **g**-vectors between the sentence marker and the origin are transforming corresponding strand-segments. The same rotation procedure relates to the range between the

root of a clause i.e., the origin and a (CM). To be sure, this is a complementary as well as a compensatory move. Displacements can be comprehended geometrically as the change or deformation of a shape. Deformation depends on a transformational move of a variable through some angles.

Changing Deformations

When a \mathbf{g} -spinor is sharing the velocities, as measured in radians and captured by the multi-vector of the A-component, the complexity of the resulting ($A = \sigma_1 A_1 + \sigma_2 A_2 + \sigma_3 A_3$) spinor describes not only a change in articulation, but also a rotation at the angle of refraction ($R = \Phi$), which concerns the direction in the timing. In further computation, radians will play a central role in forming a basis for helical deformations. Any change in a radian is contributing to the magnitudes of refraction. It follows that the multi-vector of the O-component can be described in the same way since ($1, \iota_1, \iota_2, \iota_3$) provide the common ground for a differential articulation through the operations of multi-vectors. As discussed by Connes (1994, p. 7), rotation through four right angles achieves componential identity. Thus, the function of the multi-vectors is to give a complete description of the α - and β -strands since they converge irreversibly in $|A|$ and in $|O|$.

However, a transformation, where the rotations in the supplementation (S)-function becomes equal to (e) and (σ) develops according to ($e^{i\phi/2}$), means that the principal part of the S-function conveys the “fading” in the A-component. Evidently ($\log \sigma = a + i\phi_k$) is an expression of the amount of differences in grades. The condition for this statement is that ($0 < \text{Radian} < 2\pi$) must hold. This reading of grades makes available important operations for further processing. Associated with the more advanced processing is the exponential function of the following scalar relations ($\sigma = e^A$) and ($\sigma = e^O$). For these scalars exist a logarithmic function because ($A = \log \sigma$) and ($O = \log \sigma$). If ($|A_1| < |A_k|$) and ($|O_1| < |O_k|$) then the logarithmic functions (A_L) and (O_L) can be considered to be the result of declining values.

Further, it has been shown that a symmetric asymmetry relation holds between (σ_A) and (σ_O). According to Hestenes (1986/1993, p. 30), the symmetric scalar ($\alpha \bullet \beta$) plus the asymmetric ($\alpha \wedge \beta$) bi-vector part are responsible for the coordinative integration of (α) and (β) into the ($\oslash_{\alpha+\beta}$) type. For example, the course of a “sinking” textual objective can be expressed as a series of changes: [$\sigma_O = \text{Rad}_{\text{Refraction}} - (\sqrt{\text{Rad}_1} + \sqrt{\text{Rad}_2} + \sqrt{\text{Rad}_3} + \dots k)$]. Moreover, under the condition of ($O_k = 0$), it is expected that all edges of a multi-vector with ($k > 3$) will vanish. It follows that the radiations are cutting through asymmetric points, which are located at the borders of the (a)-component.

Differences in coordinative integration can be expressed experimentally in two distinct ways. One concerns multiplicative redundancy, the other refers to the introduction of new α -variables. Redundancy specifies the degree to which a particular variable is re-addressed during the course of writing. It is a kind of repeated self-indication. As more and more edges become involved in the coordination, they indicate that one and the same variable continues to hold the line in the articulation and that the α -strand grows in its entwining and thus, the α -variables are fading away deeper and deeper into the ongoing concentration of expended energy. When a strand at the deeper level of processing becomes allied with a large radian, it gives expression to higher degrees of energy investment than a strand, associated with a small radian. Conclusively, it should be noted that the movement through a particular angle might or may not be equal to the joining radian. The larger the distance to be covered by the displacement of a variable the greater is the rate of fading. It follows that the radians of the developing α -helix constitute an apparent demonstration of biologically anchored and synthesis-producing rotational dynamics.

Taking the other helix as an explanation means that the β -strand belongs to the same time segment. A discussion of its topological value necessarily begins with the obvious fact of a double helix, whose α - and β -strands are causally determining each other. The only way the underlying dynamics can be made accessible is to articulate physically their “joint energy consumption”. When parallel effects are summarised at some specific instant (k_i), contextualisation of the α -strand is achieved. Some prior environmental conditions are thereby introduced into its determination. In conclusion, the common causal determination of the α - and β -strands can be conceived of as the functional definition of “transformed kinetic potentials”.

The Implication of $\alpha\beta$ -helix

To repeat, the constituent of a compound is assumed to be “proportional to the radius of the circular dimension of a “wrapped” (Greene, 1999, p. 238) string. Moreover, since the component of a wrapped string is supposed to have some minimum length, operating with the string-concept translates into the problem of formalising some of the basic operations that can be performed with reference to the magnitude of string vectors. This kind of operations has been expected to be sufficient for a functional expression of magnitudes. To regard a dummy as a string in a relaxed state entails a string-vector of zero magnitude.

From a thermodynamic point of view, text has to be conceived of as source for evolving spinors. Their specifying properties imply at the macroscopic level the processing of variables (g_i). Accordingly, rotational distance is taken into account. But more than one measured variable is required in order to determine concurrently the relation between variables. The basic condition (Δg) concerns the Δ -operator, which is expressing the degree of change in a sequence of variables [$g_1, g_2, g_3, \dots, g_p$]. Provided that the space equality: [$\|x \bullet x\| = \|x\|^2$] holds, the relation implies in bivector terms [$g_i \wedge g_j$], which is the foundation of the functional identity of (g_i), standing in perpendicular relation to itself (g_{ii}). Furthermore, the relation [$\|g \bullet g\| = |g| |g| \cos \theta, \phi=0$] means that the underlying rotation is endowed with a rational zero. Since, (g) folds energy on the basis of ($v_p \bullet \sigma_i$), it constitutes a positive relation with a closed convex cone. Thus, the non-commutative variable-relation [$\|g\| = (\text{Spectral radius of } g \bullet g)^{1/2}$] represents the concentration of graphemes into composites. With reference to the g -variables, tracing symmetry breaking distances is illustrated in Figure 6.

Figure 6.

Symmetry Breaking Distance of g -Variables

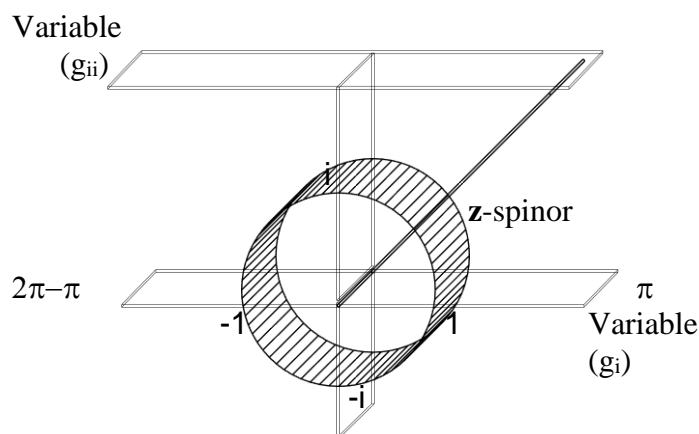

In addition, the variable-relation is contributing with the mathematical convenient property of zero distance between the variables of a binary group (G^*). For example, operations on (G^*) are taking into account relations so that even small rotational changes can contribute to the determination of a folding operation.

In manifesting the effects of (G^*) through the semantic-free patterning of (g), two kinds of operations have been observed. In the first case, it has been made obvious that certain procedures are associated with measures, which relate to the S-function's range of pulling. The effects of pulling become manifest through counting the number of steps by which variables are pulled apart. In the pulling, the equidistance of the steps has initially been marked with brackets. It follows that brackets have been used to determine the number of cross-sectional sheets of texture that have been stocked into multi-layered variables.

Formally expressed, counting of layers affords a measure on physical "stress". Hence, if a perfectly elastic text material had been produced, it would mean that all shearing and straining effects would become accessible through the folding. In addition, when related to the kinematic level, counting the dummies, involved in the production of variables, renders a measure on the degree of deformation. In normal functioning, however, like any other biophysical mechanism, the AaO-mechanism is working with materials, which are not perfectly symmetric. Some constraining effects are always concurrent with cyclic deformations. It follows that deformation of the shapes of a language space is bound to the viscous-elastic properties of the produced variables.

In the open spheres of a language space, the S-function must always control "growing string-vectors", which in the second case means that the function is working in the non-commutative context of Figure 6. However, with respect the viscous-elastic properties, determining the magnitude of "shearing" and "straining", the S-function controls "rolling" vectors, which can be observed in hyperbolic spaces. Hence, the effects of deformation become manifest through multi-layered entanglements, which are refracted through imperfect [AaO]-units. For that reason, growing must be equated with rotational differences, which are the result of differences in the energy, originally invested into perfect AaO-units and the energy, fused into imperfect units. Even more important is that this kind of differences appears at the thermodynamic level as "waves" (B. Bierschenk, 2004), which relate to various forms of "rotational accelerations".

To be able to extract or abstract the magnitude of rolling string-vectors requires the work-dynamics of perfect as well as imperfect AaO-units, which involves measurable kinematic processes. Relative phase stability in the developing of α - and β -strands has revealed that the mechanism is generating asymmetric strands. Since they are the consequences of processing, apparent overall symmetry has important theoretical implications.

Manifestation of Energy Landscapes

With the introduced novelties of open AaO-spheres, synthesis can be bound to the manifestation of invariants in hyperbolic spaces. Furthermore, since the evolution of a reading-writing style is coupled with invariants, it implies simultaneously the assumption of a dynamical coupling of synthesis with the shapes, developing in this kind of spaces. Shapes are carrying information on the particularities of an evolving style. By means of the shapes, it has also been possible to demonstrate that the invariants constitute the basis for the abstraction of unique styles and to establish the reading-writing style of an individual student. The biological mechanisms, made responsible for the formation of a style, are producing the necessary $\alpha\beta$ -strands. Their capacity to reflect personal styles has been determined through a longitudinal study (B. Bierschenk, 2005; I. Bierschenk, 2005).

In short, the background to the selection of the participants is the following: A total number of (N=30) students had participated in a longitudinal study, concerned with the phenomenon of “analysis and synthesis in dynamic learning environments” (I. Bierschenk, 2001). The present study has covered three years of learning at a Swedish Gymnasium and five test occasions. At the beginning, the participating students were classified with respect to their analytic as well as to their synthetic capacity. Through this procedure, it has been possible to test whether a structure, produced through reading and writing, pertains to the descriptive dimension (analytic sensibility) or to the reflective dimension (synthetic sensibility). Respectively, the taken approach verifies the emergence of two types (A and B) and validates their uniqueness in style. It follows that the studied participants (Bierschenk & Bierschenk, 2003 a, b, c; 2004 a) constitute the proper basis for a relational treatment of known sensibility and style (Bierschenk & Bierschenk, 2005).

The Task of Reading and Writing

Since text building behaviour develops on the basis of a cooperative interaction between “proprio-specific” and “extero-specific” processes (von Holst & Mittelstaedt, 1950) of perception that repeat themselves more or less regularly, rhythmic return through reading-writing cycles is the comprehensive principle of self-reference in text production. Moreover, with reference to these authors, Gibson (1982, p. 165) is using the term “proprioceptive” to mean “self-sensitivity”, that is the fact that the individual stimulates himself in many different ways. Hence, proprio-specific movement patterns are causally responsible for the structuring of a textual flow and the establishment of the invariant properties of one’s writing style.

In modern usage, the term “proprioceptive” is synonymous with “kinesthesia”. A source of relevance for treating one’s kinesthesia in writing refers to one’s sensibility to a literary text. Thus, grasping the essence or main idea of a work of literature, implies learning to pick up its resonance properties through particular reading exercises. Hence, sensibility is contributing to the pickup of “mental shades”, which may be different from the dominant effect of a particular piece of literature. However, even the most powerful and influential means of drawing attention to a literary work will leave considerable variability concerning individual specificity in the pickup of information. Since sensibility is bound to the pickup of invariants, reading experience affects the extraction or abstraction of the information in a selected work.

Reader distance and the order in which invariants are extracted are dependent on textual flows. It follows that flow morphologies are governing one’s reading. Like the thermodynamic properties, produced through the “wedge” formations of birds (Vogel, 2003), the thermodynamic properties, produced through the “wedge” formations of texts, are invariant, since the flow gradients of a texture are recurrent over media. Thus, central to the reading task has in the first place not been to investigate the question in what way a reader has grasped wholeness and the implicated idea or a model, but instead, it has been essential to study what has been expressed through a discourse on one’s reading.

Furthermore, when one’s kinesthesia of writing is challenged through recurrent reading exercises, sensibility may be shown to be the outcome of a helical curve of growth in knowability. Hence, the subtle core of knowability must be treated as the kinematics of refined reading-writing experiences. Therefore, the outcome of reading is expected to become decisive in the evaluation of one’s effectiveness in adapting to a particular reading task.

Sensibility as Core of Knowability

The effect of information invariants on one’s sensibility to the depth in reading is of import for the explanation of the information picked up and the kinetic energy, expended in the discourse on a particular reading task. In writing about the effects, experienced during

reading, the focus is now on how a discourse comes about, or more accurately, what really matters, what has been mediated, and what is expressed in the discourse on one's reading. In the tension between literature and science transformations of thought have been achieved, according to the empirically derived curve of Figure 7(I. Bierschenk, 1997, pp. 16-17).

Figure 7.

Growth in Knowability

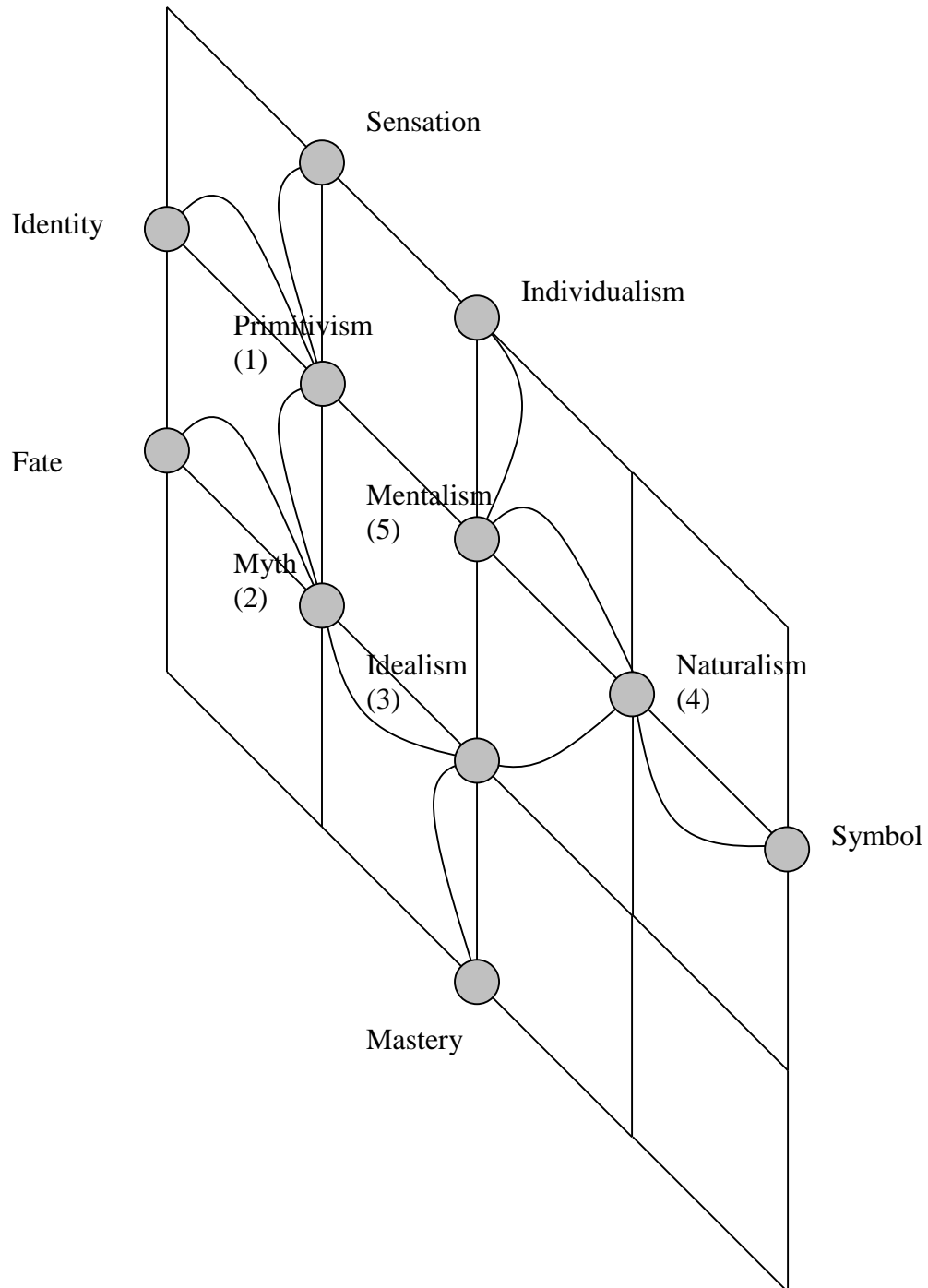

As demonstrated with the mesh, the conditions for transforming differentially structured ideas into writing have been made operational with exercises, which are referring to the terminal states at the borders. The gradients refer to the pickup of invariants of flow morphologies. However, a major problem may arise when the effects of one's reading have to be expressed through writing. At the macroscopic level, text production must result in an information synthesis. Contextual details in the realisation of wholeness and the evaluation of fitness may be expected to vanish.

Since style means the result of individual specificity in the production of information, style is a result of the flows, which are channelled through the gradients of the texture of textual surface layout. Due to the kinesthesia of writing, one's text building behaviour may vary in its effectiveness in adaptation to a particular task environment. The restrictions of a particular task environment may have serious influences on the writing effect as well as on the evaluation of fitness.

The mesh shows that this scale is initially anchored in the terminal state of "Sensation". Here, sensibility to the depth refers to the pickup of information on any unelaborated and elementary experience. Sensibility to intense feelings is the dimension on which a reader may search out the given reading task environment. But, when the transformation process is passing through the state of "Identity" one's reading experience is expected to become refined and more sensible to an early and quite primitive or naïve state of development. As a result, the first step on the evolutionary scale has been formed on the basis of a singularity, which carries the terminus "Primitivism". The naming implies sensibility to a belief in primitive customs.

The scale for the establishment of differentiated limits for growth in knowability refers at the third terminal state to "Fate", which implies that the process is transiting a state, where the reader is supposed to be concerned with imaginary (unreal) forces, affecting one's destiny. The state's transformational effect appears in the singularity "Myth", which brings the unknown (fantasy) into relation with the known. At this level, the reader is expected to be sensible to stories, dealing with characters or types that appeal to cultural awareness and commonly felt emotions.

To achieve a pre-set task and high level of functioning is usually the expression of one's possession of consummate skill and full command of the subject of study. Hence learning for "Mastery" of certain doctrines means that the transformation process is settling at the singularity "Idealism", which holds that the ultimate reality is mental and that one's mental capacity forms the complex basis for all experience and knowledge.

In the following transition, the process is passing the terminal state "Symbol". By association or resemblance, a symbol means anything that represents, signifies or indicates something else. As the result of a careful observation of events in their natural setting, symbols are considered carriers of information abstracted from expressive behaviour. Hence, this terminal state implies "regularised meaning". The resulting singularity is "Naturalism", which literally signifies to a system of thought holding that all phenomena must conform to nature and therefore, can be explained in terms of natural causes and laws, without attributing moral, spiritual or supernatural significance to them.

The final terminal state is anchoring the end of the scale in "Individualism", which indicates that the interests of the individual should take precedence over society (state) or a social group (communalism). It is also asserting one's uniqueness and that the individual should succeed by his own initiative. The transformational result appears in the state attractor, which has been named "Mentalism". According to the literal sense of this terminus, it is maintained that an adequate characterisation of human behaviour is not possible without due reference to intellectual activity, mental capacity or the inclination of a concrete mind.

Set-up of the Reading Task Environment

In the study of growth through a course on literature, it has been possible to demonstrate that the selected works constitute the proper task environment. For the study of effectiveness in adaptation to the task, discourses on reading can be compared on the basis of the presented scale. The state attractor (1) of Figure 7 concerns one's conduct of some basic thoughts about medieval conditions, which were presented in the form of an Icelandic saga, namely the saga of "Gunnlaug Ormstunga". Its characteristic style of writing is simple and on the whole free from associations to modern societal conditions.

The following state attractor (2) has been realised with the reading of Pär Lagerkvist's "The Dwarf", which is a historic novel about renaissance. It concerns one's ability to pick up the mechanisms of evil in the world and in the single person. In the novel, the course of events is put into the Italian context. Historic-political and cultural patterns form the intrigues of a dwarf at an Italian court, which result in war, catastrophe and poisoning.

In the transition through the state of learning for "Mastery" has the state attractor (3) emerged. Embedded in the context of ideas, the reader is expected to grasp certain principles and to understand their transformation into literature. For example the explanations of Rousseau and Voltaire make up the background to the reading of "Candide". This means reading about people, who, in favour of reality, become forced to give up their illusions.

In passing through the state "Symbol", central concepts of romanticism transform the stream of ideas into state attractor (4). Literary and artistic movements, validating subjective experience and the escape from the prevailing subordination of content and feeling to classical forms constitute the event horizon of "Naturalism". Thus, the course of events is developing on the basis of Darwin's ideas as well as Spencer's view on heritage, social classes and the import of evolution (time) for the human species as well as for the survival of the fittest. At this state, comprehensibility is focussing on August Strindberg's drama "Miss Julie".

Through the emergence of the "great novels", a new condition is directing one's reading experiences towards the state of "Individualism", which is focussing on scientific and ethical problems. Against this background, the state attractor (5) concerns the steering and control problems of modern societies as well as the problems associated with moral priorities. Aldous Huxley's "Brave New World", has made up the task environment for one's grasping of "Mentalism". Basically, a sensible reader may be expected to pick up functionalistic ideas, i.e., the absence of nature. On the other hand, one's reading may also have been focussed on the experience of the world of a naturalistic reserve. Both carry the characteristics of design and abnormality as well as the consequences of happiness when people love their slavery.

Controlling Limits

Now, the space-tearing hypothesis of Greene (1999, pp. 277-282) will be adopted for a rigorous examination of the validity of the (AaO) axiom for tracing the limits for knowability. From a functional point of view, it means that components of the AaO-system are not fitted into one or the other empirical context but will follow Greene's mirror-strategy. A first step requires that the A-O-pairs become divided. At a first glance, it may seem, as if this measure would destroy the strict dependency in the coordinative cooperation of the A-O-components. This would consequently imply that the production of separate A- and O-spaces should lead to results that are incomprehensible or at least not easily explainable. However, if in a second step the production of separate spaces can be shown to lead to a successful manifestation of evolving "intention" and "orientation" spaces, this step would indeed be the expression of a very radical test.

Thus, the fusion of bio-kinetic energy is dependent not only on the degree of differentiability of the produced strings of graphemes but also on coordinative cooperation of the components. When a fusion algorithm is used, which requires a linear separation of

grapheme properties, there is a risk that slightly differentiable elements lead to identical energy concentrations. In this case, it is obvious that the resulting differences are caused through the spacing of the elements. This kind of problems can be circumvented partly through the introduction of relative complex properties. But “typing” textual elements is of limited usefulness, since it is disposing information on the position of a particular element on its way from the kinetic to the kinematic level of processing. The implied loss of information concerning its exact positioning is producing potential ambiguity. Thus, the coupling of energy concentrations, related to neighbourhood, prevent ambiguity, because time-dependent coupling, speed and covalent interface smoothness are generating novel fitness conditions for the production of the energy landscapes of the source spaces.

The extent to which a landscape can give expression to the curvature of its shape has been made evident on the basis of interpolated radians and the Gaussian negative exponential function. Furthermore, the applied local smoothing is using polynomial regression and weights computed from the Gaussian density function (SigmaPlot 2004, Version 9).

Thus, in manifesting the effects of energy investment and the patterning of strings of graphemes into a latticed layer for energy exchange, it is conceivable that some text materials may have been produced that is distinguishable by linear elasticity. When this kind of elasticity is present, “Shear” versus “Strain” results in a straight line, whose slope signals the amount of produced stress or elastic stiffness. However, text resulting from the work of a biophysical mechanism must exhibit non-linear and consequently non-commutative elasticity, which means that the elasticity of a text is not constant but increasing with increasing degrees of energy exchange.

According to the design of Figure 7, the first hypothesis to be tested concerns the intention dynamics. The other hypothesis makes the assumption that the produced oscillations in the textual flows are establishing the orientation dynamics. In agreement with both hypotheses, it is expected that the fusion operations have produced detailed trajectory information. But the structurally significant aspect of this information has been captured conceptually in the naming of the kinematic states. The naming provides a sound theoretical basis. Hence, what the limits for growth and development exactly are has been established and made visible through the determination of the convolutions in the obtained fitness landscapes.

Generation of Super Symmetries

As proposed, the established fusion mechanism requires a structured task environment. Differences in invested energy are apparently resulting from differences in produced asymmetries. Changes in the working of the involved A-O-functions provide for the reflection of componential “disparity”, which is the necessary condition for the emergence of a manifold of novel super symmetries. As a consequence of the processed A-O-disparities, global singularities are supporting the differentiation of the dynamical states of evolution. The two involved fitness landscapes (A, B) are separated by certain distances in space and time as well as differences in the patterning of their singularities. When measured against the componential disparity, the energy manifested through the invariants of intention differs in certain respects from the energy conserved by the invariants of orientation. Through this double asymmetry each A-O-pair keeps a certain complementary control over every other. As demonstrated, discontinuous shifts have produced novel patterns in response to the requirements of internal adjustments to the task environment.

Maintenance of its non-equilibrium properties through symmetry-breaking operations allows a system to reflect its own internal dynamics together with the structure of its environment. Context-embedded structures are producing constraints, which are influencing one’s perspectivation and consequently, the origination of alternative energy landscapes.

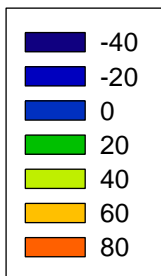
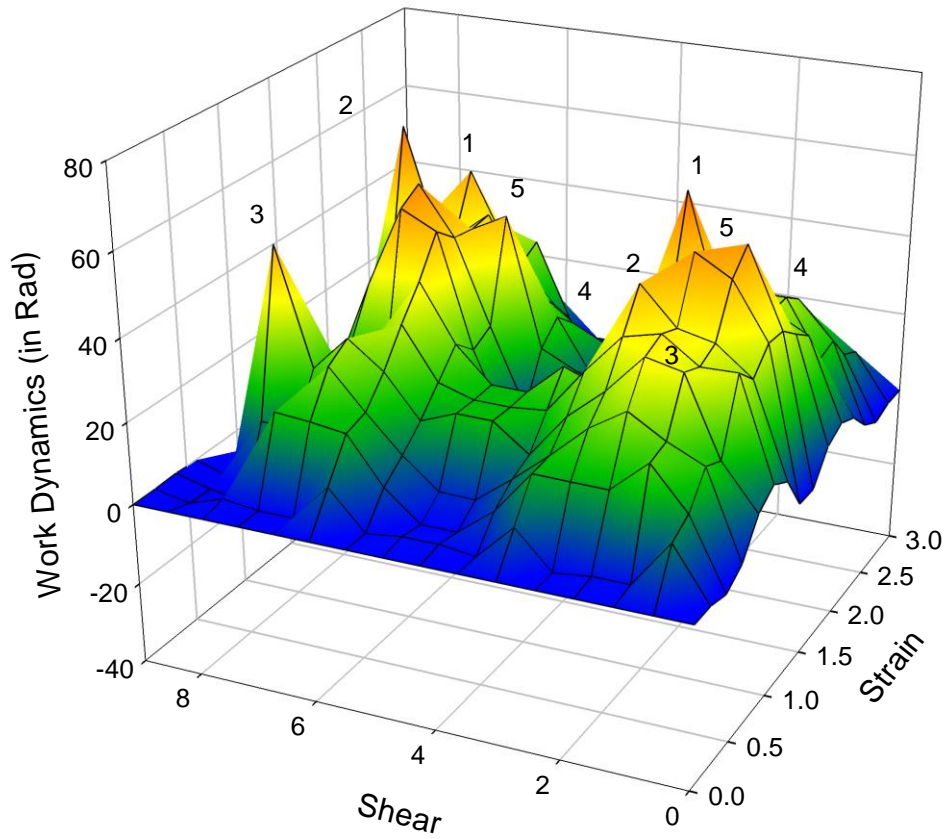
Graph A.*Bi-componential Disparity of Writing Style (A)***Global State Attractors of (A)**

- | |
|-----------------|
| (1) Primitivism |
| (2) Myth |
| (3) Idealism |
| (4) Naturalism |
| (5) Mentalism |

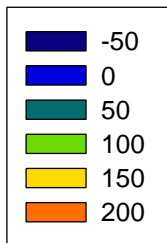
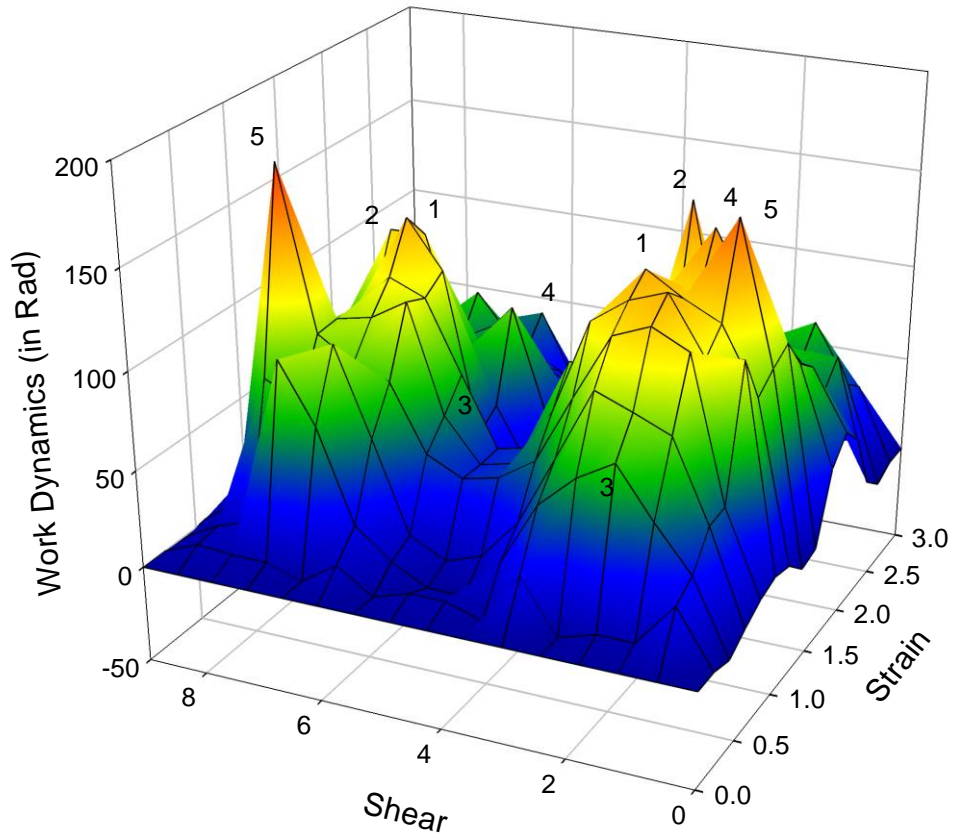
Graph B.*Bi-componential Disparity of Writing Style (B)***Global State Attractors of (B)**

- | | |
|-----|-------------|
| (1) | Primitivism |
| (2) | Myth |
| (3) | Idealism |
| (4) | Naturalism |
| (5) | Mentalism |

Changes in growth require a linkage to the same kind of tasks, but each single task operates differently on the growth curve. In evolutionary retrospect, it can be concluded that a task forms and reforms one's manifestation of intention as well as one's style of writing.

The energy invested in the A-component of the A-O-pair is demonstrated at the left-hand side of the graphs. Their right-hand side reflects the energy, invested in the O-component. An overall impression is that the asymmetries primarily are the result of individual writing styles, which are controlling the growth rates in the individual structures. Furthermore, the mechanism for elevating the global singularities of the produced structures seems to be an excellent tool for extracting the energy, invested in the growth curve. Both systemic dependencies and discontinuous local growth factors are evidently responsible for the emerging disparity in perspective.

Since a certain degree of symmetry is observable in both landscapes, investigated bio-kinetic energy is not changing the fundamental phase relation of the individual component. Despite the tendency to be periodically in an "anti-phase" mode, the components appear to repeat their particular clocking modes throughout the entire growth curve. When determined on the basis of their spiralling attractors, peak-to-peak comparison shows that each single clock prefers to stay at its own tempo. Each component is thereby satisfying its own thermodynamically specified clocking mode, which implies that each one is persisting in its own autonomous functioning, despite the observable tendency to be several times in as well as out of phase. Thus, relative phase stability remains and is thereby revealing the existence of an overall clocking symmetry.

In the first graph is a pronounced "out-of-phase" occasion observable, which concerns the singularity of "Naturalism" (4). But from a thermodynamic point of view, the observed fluctuations in the disparities are only natural, because the A-O-disparities are the result of breaking or lowering the influence of order parameters all the time. Furthermore, the overall symmetry, produced by the evolution dynamics of the growth curve, contributes with further evidence to the complementariness of the components.

The applied mirror-strategy has made it possible to study componential disparity in terms of relative as well as absolute coordination. Originally, Erich von Holst (1908-1962) introduced these terms for a refined treatment of biological dynamics, involved in phase coordination (von Holst, 1935/1973). The observed uniqueness in the oscillations of autonomous functions as well as their tendency to move in synchronised pace correspond to the invariants of the presented evolution dynamics. It follows that the competition and cooperation of the observed functions are of particular concern, since the shapes are realised through the requirement of completeness. No matter what the fitness value of a particular variable is, the shapes become realised through completeness in coordination, which means absolute coordination and the establishment of one's own private "signature".

Discussion

The assumed basic principle is bound to the Agent-action-Objective (AaO)-axiom, which is supposed to be valid for all living systems and presumes a "rotary motor" (Hernández, Kay, & Leigh, 2004), in which the $\alpha\beta$ -strands are anchored biologically. As postulation, valid for all "living things", the strand-dependencies are the foundation for the establishment of "synthesis" and consequently life, i.e., meaning. By this assumption, it is likewise stated that the derived [AaO] system is reflecting natural law.

In departing from the hypothesis that language is producing [AaO] systems according to natural law, the scientific conduct must be to explore the kinetic potentials, responsible for

the proper production of $\alpha\beta$ -strands. Furthermore, since all [AaO] system must contain their own descriptions and biological clocks, which impose the rhythms, the discovered AaO-mechanism enables the text producer to structure and change properties of a verbal outflow. Moreover, the verbal manifestation of symmetry-breaking operations allows the language system to reflect its own intrinsic structures together with the structure of its contextual environment. As a logical consequence, the solutions of the language-specific equations become determined due to the structure of the surrounding textual context.

That the clocking mode of a biological system is producing evidence for subsisting super symmetries, can be taken as justification for approaching text on the hypothesis that a reading-writing style must exist and can be made recognisable. Since it has been shown that the AaO-mechanism generates symmetries, it has also been possible to associate certain geometric properties with the dimension of intention and orientation. Their measurable effects have been demonstrated through energy landscapes. In conclusion, super symmetries are participating in the production of certain styles, whose particularities are extractable from generated energy landscapes.

Language, conceived of as a natural system, becomes structured through rhythmic driving forces, which are transforming bio-kinetic energy into the thermodynamics governing the emergence of information invariants. The present work has been advanced on the hypothesis of existing kinematic constraints constitute the fundamental precondition for treating text as an object that behaves as super-fluid solid. The validity of Hestenes "space mathematics", Greene's string-hypothesis and the assumption that strings flow without dissipation (Hurtley & Szuromi, 2004, p. 1869), links the flow of graphemes to physics. Based on "real physical geometry" (Hestenes 1986/1993, p. 583), the connection is achieved with an application of some formulations of Hestenes work with spinors (Hestenes, 1994a, b), which provides procedures and operations, which work with a 4-dimensional "spacetime" entity (Wheeler, 1996). Hence, the concepts of space and time have been concentrated in the description of the A-O-disparity.

Furthermore, the validity of Greene's space-tearing hypothesis has been related to the evolution of a language space, which is restricting flow and string-rotation as well as the movement of grapheme patterns. Hence, the focus of study has been on asymmetry and phase transitions in the development of thermodynamic constraints and their limiting effects on personal growth. To put strings of graphemes into the "perspective" of a particular text producer requires both practice and experiences with the usage of words. Moreover, the ability to read and to write ties one's style of writing not only to one's background but also to one's capacity to apprehend the constraints. Expressed in experimental terms, the kinesthesia of writing as well as one's sensibility to the context of a particular task environment is gating the pick up of intrinsic tendencies.

Experimentally it has been demonstrated that language must be treated as a "bio-kinematic displacement system", which exhibits periodic behaviour. In using the rhythmic, clock-like working mode as well as Greene's the mirror strategy has made it possible to determine componential disparity. Finally, in studying fitness values, it has been possible to establish super symmetries as an expression of effectiveness in adaptation and to describe the theoretical significance of adaptive-ness in terms of invariant temporal morphologies.

References

- Bierschenk, B. (2004). Transformation of a word model: String rotation and pattern dynamics in the production of abstract geometric spaces. *Cognitive Science Research*, 92. Copenhagen: Copenhagen University, Copenhagen Competence Research Centre & Lund University: Department of Psychology.
- Bierschenk, B. (2005). The morphogenesis of intention and structural stability of motifs. *Cognitive Science Research*, 96. Copenhagen: Copenhagen University, Copenhagen Competence Research Centre & Lund University: Department of Psychology.
- Bierschenk, B., & Bierschenk, I. (2003a). Manifestation of symmetry between the emergence of consciousness and the development of competence. *Cognitive Science Research*, 86. (ERIC Document Reproduction Service, No. ED 472 156, TM 034 723)
- Bierschenk, B., & Bierschenk, I. (2003b). Individual growth in competence. *Cognitive Science Research*, 87. Copenhagen: Copenhagen University, Copenhagen Competence Research Centre & Lund University: Department of Psychology.
- Bierschenk, B., & Bierschenk, I. (2003c). Evolution of growth in the development of competence. *Cognitive Science Research*, 88. Copenhagen: Copenhagen University, Copenhagen Competence Research Centre & Lund University: Department of Psychology.
- Bierschenk, B., & Bierschenk, I. (2004a). Heterogeneity in the apprehension of adaptation and justice. *Cognitive Science Research*, 91. Copenhagen: Copenhagen University, Copenhagen Competence Research Centre & Lund University: Department of Psychology.
- Bierschenk, B., & Bierschenk, I. (2004b). Intuitive judgement in the context of constructivism. *Cognitive Science Research*, 93. Copenhagen: Copenhagen University, Copenhagen Competence Research Centre & Lund University: Department of Psychology.
- Bierschenk, I. (1997). Discovery of competence at the edge of literature and society. *Cognitive Science Research*, 64. (ERIC Document Reproduction Service, No. ED, TM 029 092).
- Bierschenk, I. (2001). Development of competence in dynamic learning environments. *Cognitive Science Research*, 79. (ERIC Document Reproduction Service, No. ED 452 240, TM 032 526)
- Bierschenk, I. (2005). An Evolutionary scale as standard for controlling the quality of writing style. *Cognitive Science Research*, 95. Copenhagen: Copenhagen University, Copenhagen Competence Research Centre & Lund University: Department of Psychology.
- Bierschenk, I., & Bierschenk, B. (2004). Diagnose der Leistungsheterogenität durch die Perspektivische Textanalyse: VERTEX [Diagnosing heterogeneity in achievement by means of Perspective Text Analysis: VERTEX]. In: W. Bos, E.-M. Lankes, N. Pläßmeier, & K. Schwippert (Eds.), *Heterogeneity: Eine Herausforderung an die Bildungsforschung [Heterogeneity: A Challenge to Educational Research]* (pp.16-28). Münster: Waxmann.
- Connes, A. (1994). *Noncommutative geometry*. New York: Academic Press.
- Gibson, J. J. (1982). The uses of proprioception and the detection of propriospecific information. In E. Reed, & R. Jones (Eds.), *Reasons for realism* (pp. 164-170). Hillsdale, NJ: Erlbaum.
- Greene, B. (1999). *The elegant universe. Superstrings, hidden dimensions, and the quest for the ultimate theory*. New York: W. W. Norton & Company.

- Hernández, J. V., Kay, E. R., & Leigh, D. A. (2004). A reversible synthetic rotary molecular motor. *Science*, *306*, 1532-1537.
- Hestenes, D. (1986/1993). *New foundations for classical mechanics*. Dordrecht: Kluwer Academic. (Original work published 1986)
- Hestenes, D. (1994a). Invariant body kinematics: I. Saccadic and compensatory eye movements. *Neural Networks*, *7*, 65-77.
- Hestenes, D. (1994b). Invariant body kinematics: II. Reaching and neurogeometry. *Neural Networks*, *7*, 79-88.
- Hurtley, S., & Szuromi, P. (2004). This week in Science: A superfluid solid, *Science*, *305*, 1869.
- Lloyd, S. (2001). Computation from geometry. *Science*, *292*, 1669.
- SigmaPlot (2004). *SigmaPlot 9.0: User's manual* (Version 9). Chicago: SPSS Inc.
- Vogel, S. (2003). *Comparative biomechanics: Life's physical world*. Princeton, NJ: Princeton University Press.
- von Holst, E. (1973). *The behavioural physiology of animal and man*. München: Piper, 1969. (Original work: Zur Verhaltensphysiologie bei Tieren und Menschen: Gesammelte Abhandlungen, Band 1, published, 1935)
- von Holst, E., & Mittelstaedt, H. (1950). Das Reafferenzprinzip: Wechselwirkungen zwischen Zentralnervensystem und Peripherie [The reafference principle: Interaction between central nervous system and periphery]. *Die Naturwissenschaften*, *37*, 464-476.
- Wheeler, J. A. (1998). *Geons, black holes & quantum foam: A life in physics*. New York: Norton.
- Winfree, A. T. (1980). *The geometry of biological time*. Berlin: Springer Verlag.

Accepted November 25, 2005

Author's Note

Correspondence and requests for materials should be addressed to Bernhard F. Bierschenk, Department of Psychology at Lund University, Paradisgatan 5P, S-223 50 Lund, Sweden. E-mail bernhard.bierschenk@psychology.lu.se