



LUND UNIVERSITY

Modelling Steel Behaviour

Anderberg, Yngve

1986

[Link to publication](#)

Citation for published version (APA):

Anderberg, Y. (1986). *Modelling Steel Behaviour*. (LUTVDG/TVBB--3028--SE; Vol. 3028). Division of Building Fire Safety and Technology, Lund Institute of Technology.

Total number of authors:

1

General rights

Unless other specific re-use rights are stated the following general rights apply:

Copyright and moral rights for the publications made accessible in the public portal are retained by the authors and/or other copyright owners and it is a condition of accessing publications that users recognise and abide by the legal requirements associated with these rights.

- Users may download and print one copy of any publication from the public portal for the purpose of private study or research.
- You may not further distribute the material or use it for any profit-making activity or commercial gain
- You may freely distribute the URL identifying the publication in the public portal

Read more about Creative commons licenses: <https://creativecommons.org/licenses/>

Take down policy

If you believe that this document breaches copyright please contact us providing details, and we will remove access to the work immediately and investigate your claim.

LUND UNIVERSITY

PO Box 117
221 00 Lund
+46 46-222 00 00

LUND INSTITUTE OF TECHNOLOGY · LUND · SWEDEN
DIVISION OF BUILDING FIRE SAFETY AND TECHNOLOGY
REPORT LUTVDG/(TVBB - 3028)
ISSN 0282 - 3756

YNGVE ANDERBERG

MODELLING STEEL BEHAVIOUR

LUND 1986

Division of Building Fire Safety
and Technology
Lund Institute of Technology
Box 118
S-221 00 LUND, Sweden
Tel +46-46-10 73 60

Report LUTVDG/(TVBB-3028)(1986)

ISSN 0282-3756

Brandteknik
Lunds Tekniska Högskola
Biblioteket

Yngve Anderberg

MODELLING STEEL BEHAVIOUR

LUND 1986

Presented at the International Conference on Design of Structures
Against Fire, held at Aston University, Birmingham, U.K. on the
15th and 16th of April 1986

Research project financed by the Swedish Fire Research Board
(BRANDFORSK)

MODELLING STEEL BEHAVIOUR

YNGVE ANDERBERG

Division of Building Fire Safety and Technology -
Lund Institute of Technology
Lund, SWEDEN

Abstract

When modelling material mechanical behaviour, an analytical description is required of the relationship between stresses and strains. A computer oriented mechanical behaviour model for steel is described. The model is based on the fact that the deformation process at transient high temperature conditions can be described by three strain components which are separately found in different steady state tests. It is shown that a behaviour model based on steady state data satisfactorily predicts behaviour in transient tests under any given fire process, load and strain history.

The test method used for determining strength properties is of great importance for the obtained result. By using the model a procedure is shown how to couple steady state and transient state results and make them comparable for design.

Sometimes the behaviour model for design purposes is simplified by using constructed stress-strain curves based on transient state results. This means that creep from the transient test is included in an approximate way in the stress-strain curves. The consequence of this simplification in a computation is illustrated for steel structures approaching creep failure under fire attack.

BACKGROUND

When developing an analytical behaviour model of steel at high temperatures one needs a great amount of data on the stress and deformation characteristics at different temperature histories. The model must be based on reliable and well-documented results from tests carried out under well defined and controlled conditions. A careful distinction must be made between steady state (stabilized) and transient state conditions. Steels behave in many ways differently and therefore hot-rolled and cold-worked reinforcing steel, structural steel and prestressing steel must be separated.

It is important to have in mind the different test procedures for determining the mechanical properties.

There exist two main groups of tests, steady state tests and transient state tests. Material properties measured are closely related to the test method used. It is therefore of great importance that the test conditions are well defined.

During a fire situation the material is normally subjected to transient processes with varying temperature and stress, and to understand this, transient state tests are needed.

Mechanical properties of steel can be established by following a number of different test procedures. The three main test parameters are the heating process, application and control of load, and control of strain. These can have constant values or be varied during testing, giving steady state or transient state conditions depending on the heating procedure.

Six practical regimes which can be used for determining mechanical properties are illustrated in Fig. 1. Properties in these regimes are as follows:

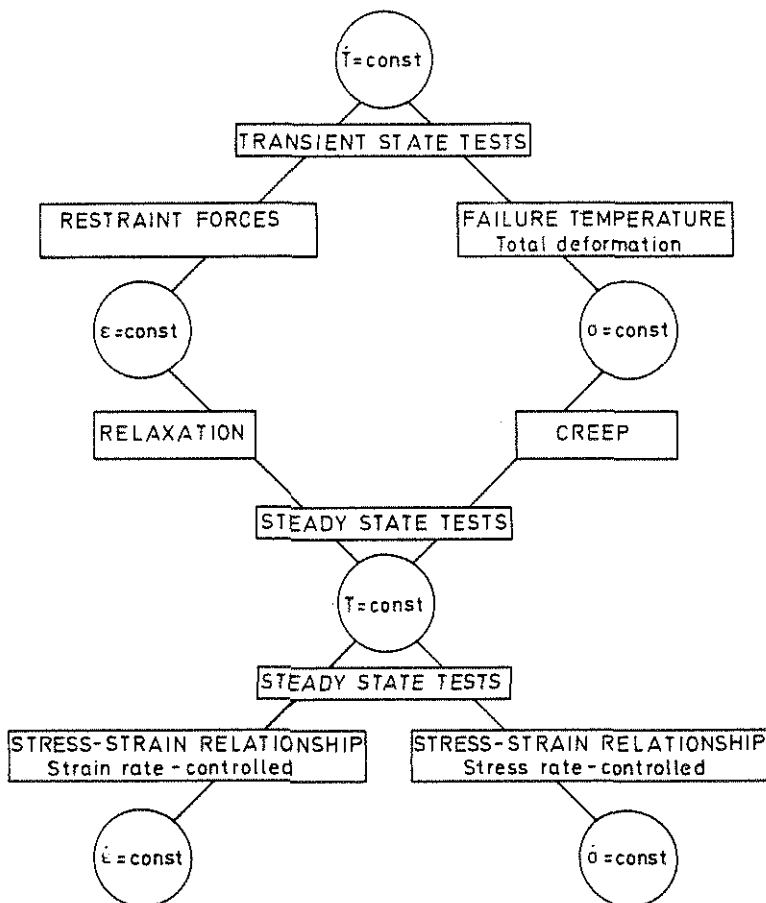

Fig. 1 Different testing regimes for determining mechanical properties
RILEM 44-PHT (1983)

Steady state tests

- stress-strain relationship (stress rate control)
- stress-strain relationship (strain rate control)
- creep
- relaxation

Transient state tests

- failure temperatures, total deformation (stress control)
- restraint forces, total forces (strain control)

Steady state tests are characterized by a heating period and a period of time during which the temperature of the specimen is stabilized before any load is applied. The strain measured before the load is applied corresponds to the thermal expansion.

Transient state tests or non-steady state tests are characterized by a varying temperature and a simultaneous load. The load can be applied before heating or developed during heating by restraint against thermal expansion. These two types of transient tests are carried out with load and strain control, respectively.

GENERAL MODEL

It is generally agreed that the deformation process of steel at transient high temperatures can be described by three strain components defined by the constitutive equation

$$\epsilon = \epsilon_{t,r}(T) + \epsilon_{\sigma}(\sigma, T) + \epsilon_{c,r}(\sigma, T, t) \quad (1)$$

where

- $\epsilon_{t,r}$ = thermal strain
- ϵ_{σ} = instantaneous, stress-related strain based on stress-strain relations obtained under constant, stabilized temperature
- $\epsilon_{c,r}$ = creep strain or time dependent strain.

A computer oriented mechanical behaviour model for steel, based on Eq. (1), is developed in Anderberg (1976) /1/.

The strains are found separately in different steady state tests. It is shown that a behaviour model based on steady state data satisfactorily predicts behaviour in transient tests under any given fire process, load and strain history.

Thermal strain

The thermal strain or thermal expansion is measured on unloaded specimens in a transient test. Investigations published in literature indicate small deviations for structural and prestressing steels. Type of steel and strength characteristics seem to have no significant influence. In Fig. 2 the thermal strain for structural steel is taken from four

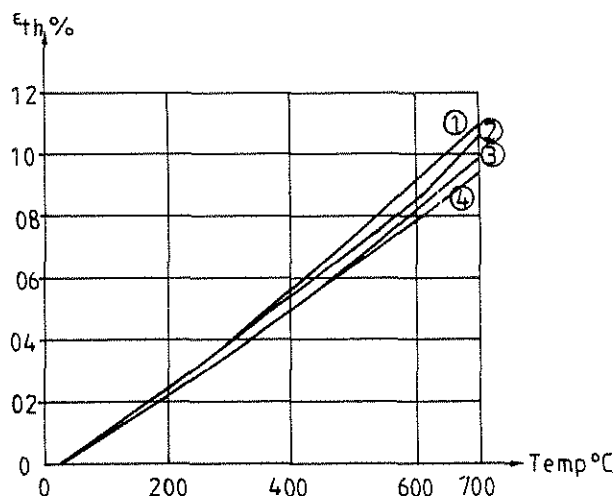

Fig. 2 Thermal strain (expansion) for structural steel as function of temperature

- 1 St 37-2, Ruge & Winkelmann (1978-80) /12/
- 2 Steel 37, Skinner (1972) /13/
- 3 A 36, Harmathy (1967) /8/
- 4 Stirland (1980) /14/

different sources. The curves are relatively close together.

A linear relationship is most often used in analytical modelling.

Instantaneous stress-related strain

The σ - ϵ relationship can be measured under stress rate or strain rate control. The stress strain relationship must be obtained at a high rate of loading or high rate of strain in order to avoid the influence of creep, which is of importance above about 400°C for ordinary steel (for cold-worked or prestressing steel above about 250°C). The influence of creep results in a displaced σ - ϵ curve and in a lower ultimate (rupture) strength. The σ - ϵ curves can be used to establish compressive or tensile strength, modulus of elasticity and ultimate strain.

Experimental results published in Anderberg (1978) /2/ indicate that reinforcing and structural steel have a similar dimensionless σ - ϵ relationship as illustrated in Fig. 3 at 400 and 600°C.

An analytical description of the σ - ϵ curve as a function of temperature can be made in different ways. The experimental curve can be approximated by a number of straight lines or by a modified expression of Ramberg & Osgood (1943) used in Magnusson (1974) as follows

$$\epsilon_{\sigma} = \sigma/E(T) + 3/7 \cdot f_{0.2,T}/E(T) \cdot (\sigma/f_{0.2,T})^{m+1} \quad (2)$$

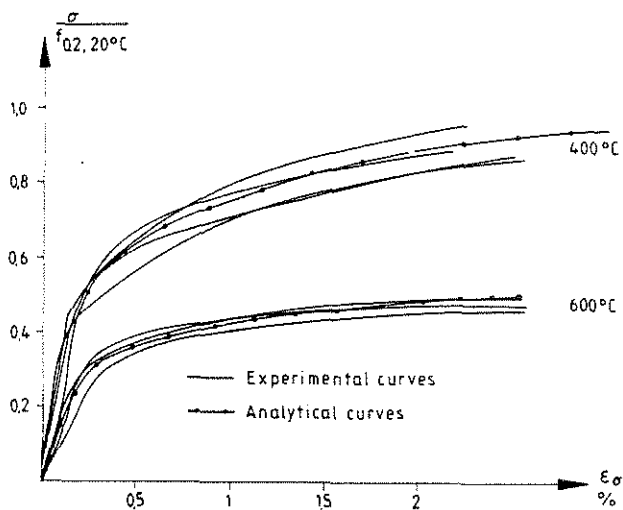

Fig. 3 Dimensionless σ - ϵ relationship for 4 different kinds of reinforcing steel at 400°C and 600°C. The theoretical curve is also shown

where

$$6 \leq m(T) \leq 50$$

$E(T)$ = modulus of elasticity at temperature T

$f_{0.2, T}$ = 0.2% proof stress at temperature T

In this paper the dimensionless σ - ϵ relationship is described by a straight line followed by an elliptic branch and a straight line as illustrated in Fig. 4. The parameters α , β and ϵ_1 are dependent on temperature level and type of steel (Dounas & Golrang 1982) /5/.

The analytical expressions are

Reinforcing and structural steel:

$$\sigma = \epsilon_{\sigma} \cdot E(T) \quad 0 \leq \epsilon_{\sigma} \leq \epsilon_1 \quad (3)$$

$$\sigma = 2\beta + b\sqrt{1 - (0.03 - \epsilon_{\sigma}/a)^2} \quad \epsilon_1 \leq \epsilon_{\sigma} \leq 2a \quad (4)$$

$$\sigma = b + 2\beta(\epsilon_{\sigma} - 0.03) / (0.0123 - 0.00085 \cdot T) \quad \epsilon_{\sigma} \geq 2a \quad (5)$$

Prestressing steel:

$$\sigma = \epsilon_{\sigma} \cdot E(T) \quad 0 \leq \epsilon_{\sigma} \leq \epsilon_1 \quad (6)$$

$$\sigma = 2\beta + b\sqrt{1 - (2a - \epsilon_{\sigma}/a)^2} \quad \epsilon_1 \leq \epsilon_{\sigma} \leq 2a \quad (7)$$

$$\sigma = b + 2\beta \quad \epsilon_{\sigma} \geq 2a \quad (8)$$

The curve fitting for reinforcing and structural steel at 400 and 600°C is illustrated in Fig. 3.

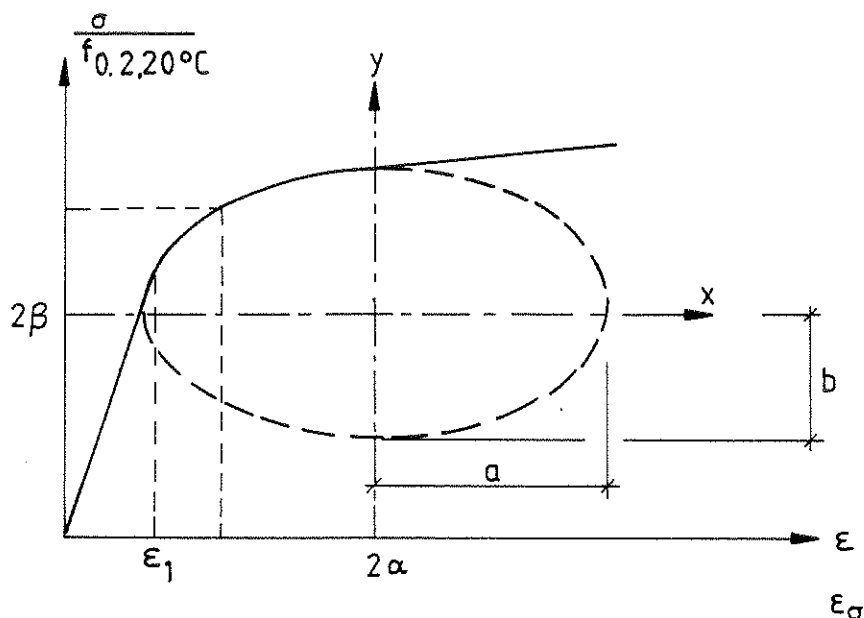

Fig. 4 Principal model of dimensionless σ - ϵ relationship

CREEP STRAIN

Creep behaviour is unique for every type of steel and a common description is hard to find. This is due to the fact that the chemical composition and the degree of processing strongly influences this. The creep tendency seems not to be related to the 0.2% proof stress or other strength characteristics at room temperature. Therefore the absolute value of stress is used when describing creep analytically.

The creep strain can only be directly measured in steady state tests and if the stress is kept constant it can be separated into two phases, primary and secondary phase. However, the creep from steady state tests can be used in order to predict the creep process in transient tests, which will be illustrated.

Models of creep are in most cases based on a concept put forward by Dorn (1954) /4/, in which the effect of variable temperatures is considered. The extension of the model to be applicable to variable stress can, for instance, be based on the strain hardening rule.

The creep strain modelled in this paper is assumed to be dependent on the magnitude of stress and on the temperature-compensated time evaluated from the expression

$$\theta = \int_0^t e^{-\frac{\Delta H}{RT}} dt \quad (h) \quad (9)$$

where

ΔH = activation energy of creep, J/mol

R = gas constant, J/mol·K

t = time.

The relation between creep strain, ϵ_{cr} , and temperature-compensated time, θ , at a given stress level is shown principally in Fig. 5.

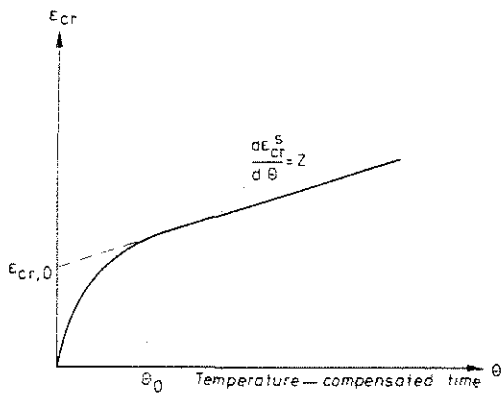

Fig. 5 Principal creep curve for the steel according to Dorn's theory

The change from the curved branch to the straight line (primary and secondary phase) is denoted θ_0 and the intersection between the straight line and the creep axis is called $\epsilon_{cr,0}$. The slope of the straight line is called Z . The primary phase is defined by a parabolic equation and the secondary phase by a linear slope. The transfer occurs at time θ_0 . The mathematical formula is

$$\begin{aligned} \epsilon_{cr} &= \epsilon_{cr,0} \cdot (2\sqrt{Z \cdot \theta / \epsilon_{cr,0}}) & 0 \leq \theta < \theta_0 \\ \epsilon_{cr} &= \epsilon_{cr,0} \cdot (1 + (Z \cdot \theta / \epsilon_{cr,0})) & \theta \geq \theta_0 \end{aligned} \quad (10)$$

where

$$\theta_0 = \epsilon_{cr,0} / Z \quad (11)$$

Harmathy (1967) has derived an analytical expression between ϵ_{cr} and the parameters θ , Z and $\epsilon_{cr,0}$ as follows:

$$\epsilon_{cr} = (\epsilon_{cr,0} / \ln 2) \operatorname{arcosh} \left(2^{Z\theta / \epsilon_{cr,0}} \right) \quad (12)$$

This formula is not that practical and unnecessary complicated.

Creep parameters for different kind of steels and used in calculations are collected in Table 5.1 in Rilem (1983) /11/. The following equations are governing Z and $\epsilon_{cr,0}$:

$$\epsilon_{cr,0} = A \cdot \sigma^B \quad (13)$$

$$Z = \begin{cases} C \cdot \sigma^D & \text{if } \sigma \leq \text{SIG } 1 \\ H \cdot e^{-\sigma} & \text{if } \sigma > \text{SIG } 1 \end{cases} \quad (14)$$

In /2/ the modified version of the Dorn-Harmathy theory, described above, has been used and the concordance between test and calculation is shown in Fig. 6.

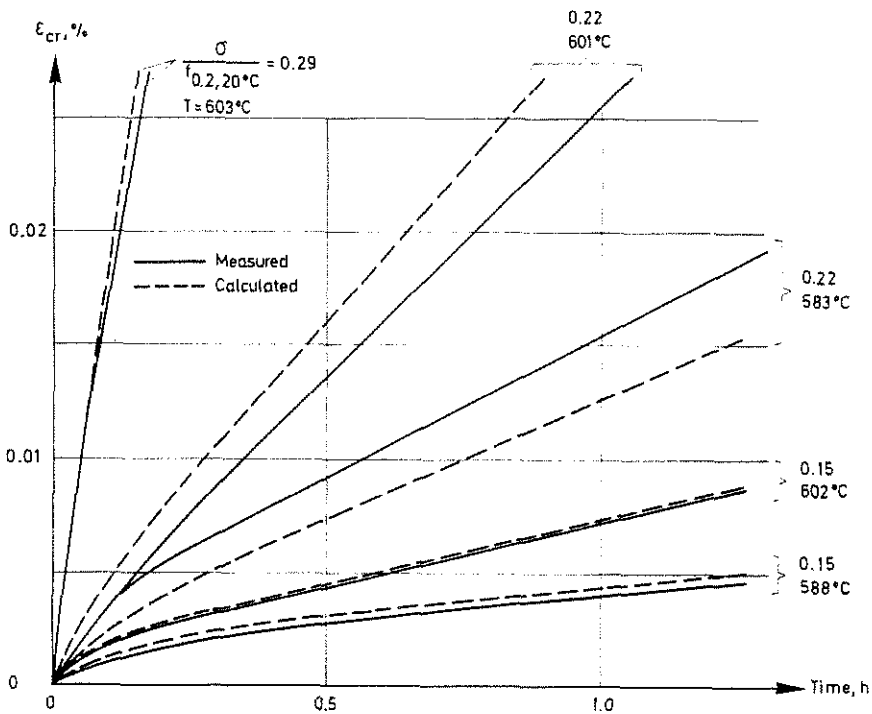

Fig. 6 Measured and predicted creep (modified Dorn-Harmathy theory) at different stress levels. Reinforcing steel Ks 60 ϕ 8, $f_{0.2, 20^\circ\text{C}} = 710$ MPa, Anderberg (1978), /2/

A simplified way is to approximate the creep curve by two straight branches with slopes Z_p and Z_s /2/ as illustrated in Fig. 7.

The creep strain is an explicit function of time, temperature and stress, where

$$\epsilon_{cr}(t, T, \sigma) = t \cdot Z(T, \sigma) \quad (15)$$

$$\epsilon_{cr} = Z_p(T, \sigma) \quad \text{if } 0 \leq t \leq t_1 \quad (16)$$

$$\epsilon_{cr} = Z_s(T, \sigma) \quad \text{if } t > t_1$$

Nomograms for the rate of creep in primary and secondary phase for reinforcing steel Ks 40 ϕ 8 are published in /2/.

These nomograms including the determination of the transition time, t_1 , facilitate an estimation of the magnitude of creep.

In Japan creep formulations also are developed and Furamura et al (1985) /6/ presents a formula for structural steel SS 41 as follows

$$\epsilon_{cr} = 10^{12} \cdot \sigma^{10} \cdot t^{0.5} \cdot e^{-\frac{10000}{T}} \quad (17)$$

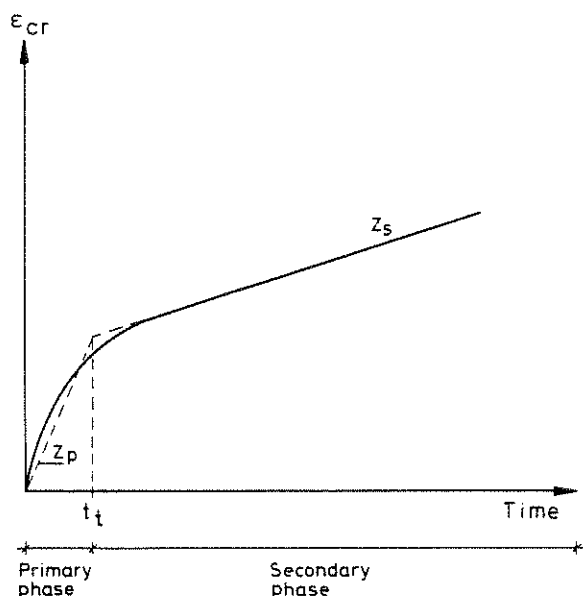

Fig. 7 Measured creep curve approximated by two straight branches with slopes Z_p and Z_s , Anderberg (1978), /2/

where

$$a = -7.21 \cdot 10^3$$

$$b = 3.26$$

$$c = 1.55 \cdot 10^3$$

$$d = 2.25$$

$$e = 8.98 \cdot 10^4$$

$$f = -3.30 \cdot 10^{-1}$$

T = absolute temperature

t = time in minutes

σ = stress kg/mm^2

ϵ_{cr} = creep strain %

The effect of variable stress and temperature is solved by using a modification of the strain hardening rule.

RELAXATION

A relaxation test is closely related to a creep test but is carried out at constant strain and temperature (Fig. 1) and the stress decrease is studied as function of time. The relaxation process can analytically be found by using the formulation of creep and the instantaneous stress-related strain as follows.

The total strain is constant, which means that the sum of ϵ_{σ} and ϵ_{cr} is constant. The increase in creep must be followed by the same decrease in ϵ_{σ} . The stress must therefore decrease with time in such a way that ϵ_{σ} decreases as ϵ_{cr} increases.

$$\epsilon_{\sigma,t} = \text{const} = \epsilon_{\sigma}(\sigma, T) + \epsilon_{cr}(\sigma, T, t) \quad (18)$$

Dimensionless relaxation curves measured and predicted for reinforcing steel are compared in Fig. 8. The agreement is very good.

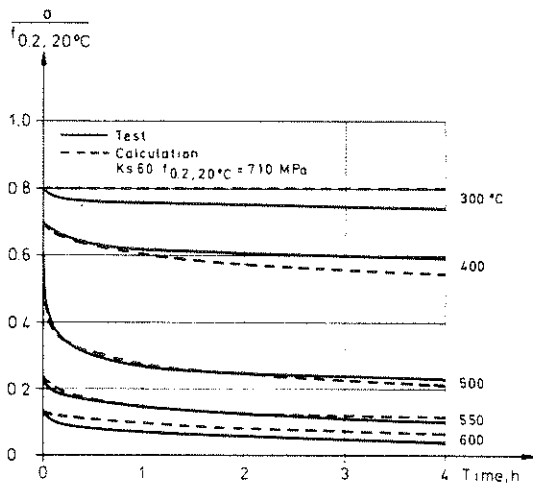

Fig. 8 Measured and predicted relaxation curves for reinforcing steel (Anderberg 1978), /2/

Total strain

The behaviour model is based on steady state data, but the creep can be predicted at varying load and temperature (transient process) by using the strain hardening rule. This means that any test can be simulated by using the complete behaviour model as expressed above.

The total deformation as a function of temperature measured in a transient test, $T = 10^\circ\text{C}/\text{min}$, is calculated and the comparison is illustrated in Fig. 9.

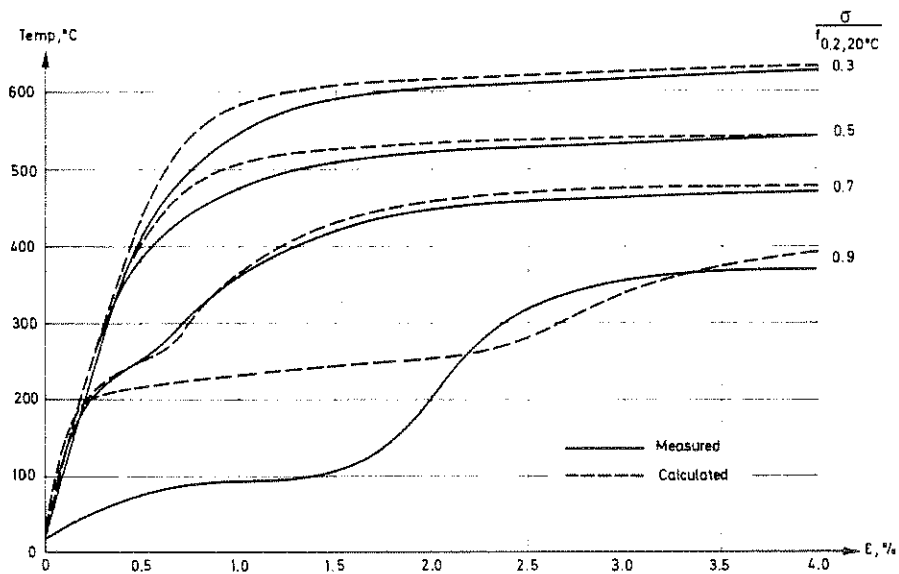

Fig. 9 Measured and predicted total deformation as a function of temperature at different load levels in a transient process, $T = 10^\circ\text{C}/\text{min}$. Reinforcing steel Ks 60 $\phi 8$, $f_{0.2, 20^\circ\text{C}} = 710 \text{ MPa}$ Anderberg (1983) /3/

There is a good agreement between test and calculation. However, there is a discrepancy at the load level $\sigma/f_{0.2,20^{\circ}\text{C}} = 0.9$ and temperature region 100-300°C. This is due to an instability phenomenon in the material called "thermal activated flow", which only occurs in transient tests. This characteristic feature has been observed in many experimental investigations and sometimes the deformation results from two identical tests may differ very much in the temperature region 100-300°C. This is due to a more pronounced thermal activated flow in one of the tests.

HOW TO COUPLE STEADY STATE AND TRANSIENT STATE RESULTS

Analytical modelling illustrated above makes it possible to couple steady state tests and transient state tests. For instance, the strain or stress rate can be determined in steady state tests to give the same ultimate strength as occurs in a transient test for a given rate of heating.

The predicted influence of stress and strain rates on the stress-strain relationship under steady state conditions can be studied in Figs. 10-11. From such curves the ultimate strength as a function of temperature can be evaluated. In Fig. 12 a-b, the influence of stress and strain rates on the ultimate strength under steady state conditions is illustrated. The influence of rate of temperature under transient state conditions is given in Fig. 12 c. The ultimate strength is defined by the stress at which the strain is 4%, the thermal strain excluded.

In the analytical modelling the strain and stress rate in a steady state procedure to give the same ultimate strength as under transient state conditions is found, if the rate of heating is chosen to be 10°C/min.

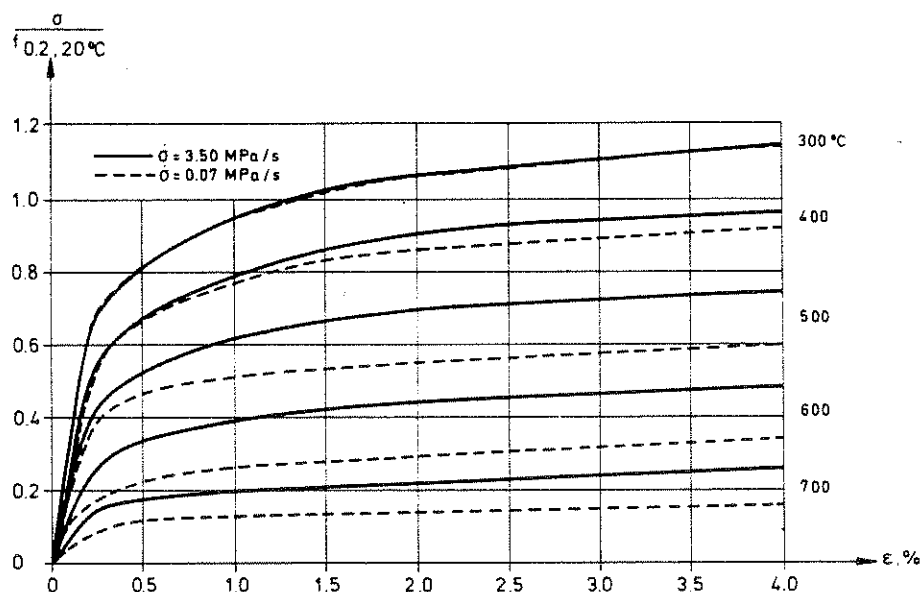

Fig. 10 Predicted σ - ϵ curves at different stress rates for reinforcing steel (K_s 60, $f_{0.2,20^{\circ}\text{C}} = 710$ MPa), Anderberg (1983) /3/

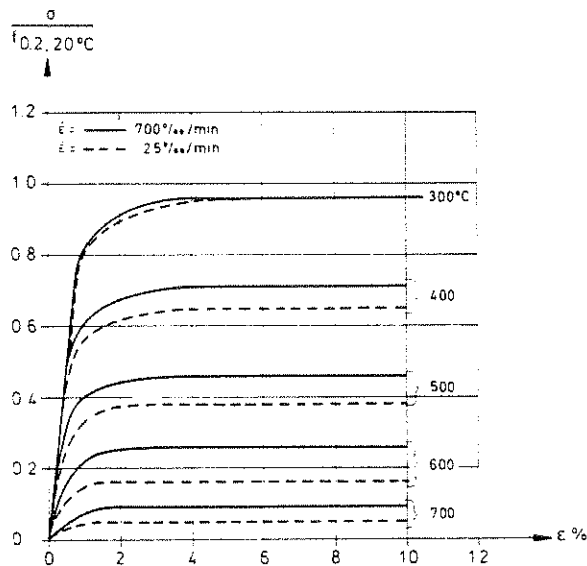

Fig. 11 Predicted σ - ϵ curves at different strain rates for pre-stressing steel (ASTM A 421-65, $f_{0.2, 20^\circ\text{C}} = 1470$ MPa), Anderberg (1983), /3/

The result is shown in Fig. 12 d for a specific reinforcing steel (Ks 60, $f_{0.2, 20^\circ\text{C}} = 710$ MPa). The strain and stress rates obtained by computation are thus

$$\dot{\epsilon} = 20^\circ/\text{oo}/\text{min}$$

and

$$\dot{\sigma} = 0.20 \text{ MPa/s} = 12 \text{ MPa/min}$$

These values vary somewhat depending on the type of steel, which is shown in Table 1 for,

- structural steel 1411, $f_{0.2, 20^\circ\text{C}} = 340$ MPa
- hot-rolled reinforcing steel Ks 40, $f_{0.2, 20^\circ\text{C}} = 456$ MPa
- hot-rolled reinforcing steel Ks 60, $f_{0.2, 20^\circ\text{C}} = 710$ MPa
- prestressing steel ASTM A 421-65, $f_{0.2, 20^\circ\text{C}} = 1470$ MPa

Table 1

Type of steel	\dot{T} °C/min	$\dot{\sigma}$ MPa/s	$\dot{\epsilon}$ °/oo/min
Steel 1411	10	0.20	10
Ks 40	10	0.20	10
Ks 60	10	0.20	20
ASTM A 421-65	10	0.50	10

For the additional steels in Table 1 the results of computation are given in diagrams in /3/. Such diagrams can be used for design as illustrated in /3/.

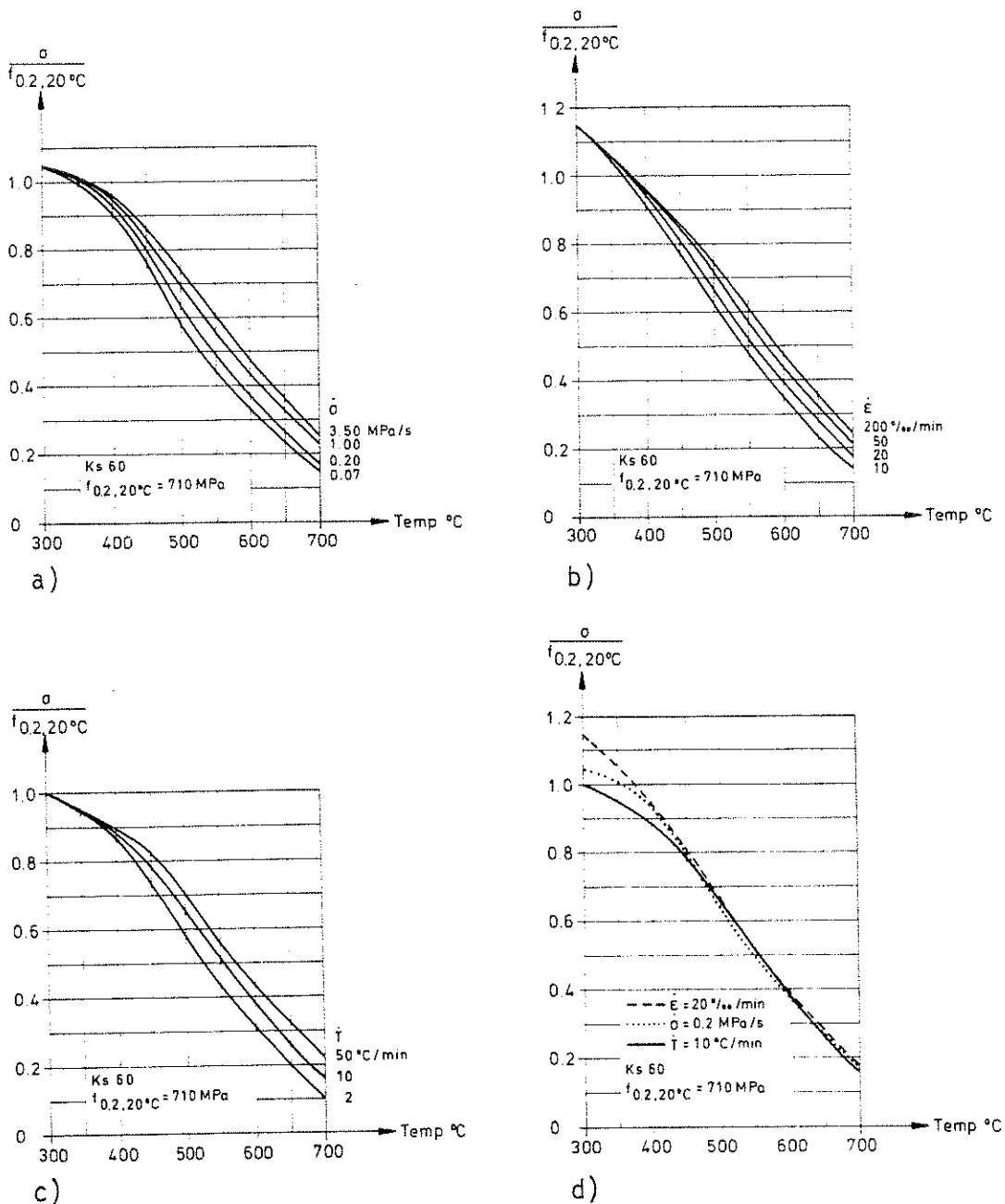

Fig. 12 Predicted ultimate strength versus temperature for reinforcing steel, Anderberg (1983), /3/
 a) steady state, stress rate controlled
 b) steady state, strain rate controlled
 c) transient state
 d) comparison between steady state and transient state

If the strength-temperature curve, based on the transient state condition where for instance $\dot{T} = 10^\circ\text{C}/\text{min}$ is accepted as a reference curve, test results can be directly interpreted and, thus, comparable. If the rates $\dot{\epsilon}$ and $\dot{\sigma}$ are below the values mentioned above, the measured ultimate strength should be corrected downwards.

The rate of stress or strain in a steady state test and the rate of tem-

perature in a transient test are governing the development of creep which causes the change in the ultimate strength. The influence of creep for these procedures is fully illustrated in /3/.

SIMPLIFIED MODEL

For design purpose a simplified model is used in practice, where the creep strain in an approximate way is incorporated in the stress-strain relationship. The model is solely based on transient state tests and the procedure to construct the σ - ϵ relationship is as follows.

The total deformation measured in a transient test at a constant stress and increasing temperature until failure occurs minus the thermal strain as function of temperature is illustrated in Fig. 13. From these curves, σ - ϵ relationships can be constructed in which the creep strain corresponding to a specified heating rate is included.

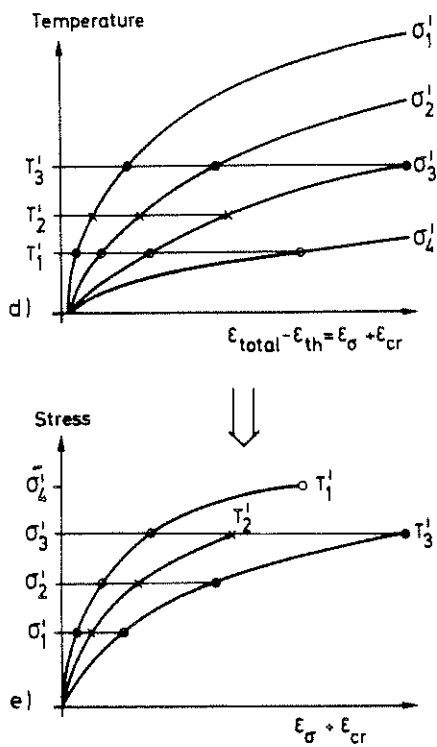

Fig. 13 Transient tests with load control
 a) Typical ϵ - T curves at different stress levels
 b) Constructed σ - ϵ curves at different temperatures

σ - ϵ curves from steady state and transient state tests at different temperatures are compared to each other in Fig. 14. Agreement between calculations and measurements is also close. The curve of the steady state conditions contains no creep due to the high stress rate. In the curve of the transient state conditions the influence of creep is, however, of importance. The difference between the curves at $\epsilon > 2\%$ and the decrease in ultimate strength at 500 and 600°C amount to about 15% of $f_{0.2, 2000}$. This difference also is very much dependent on the heat-

ing rate in the transient test, compare with Fig. 12 c.

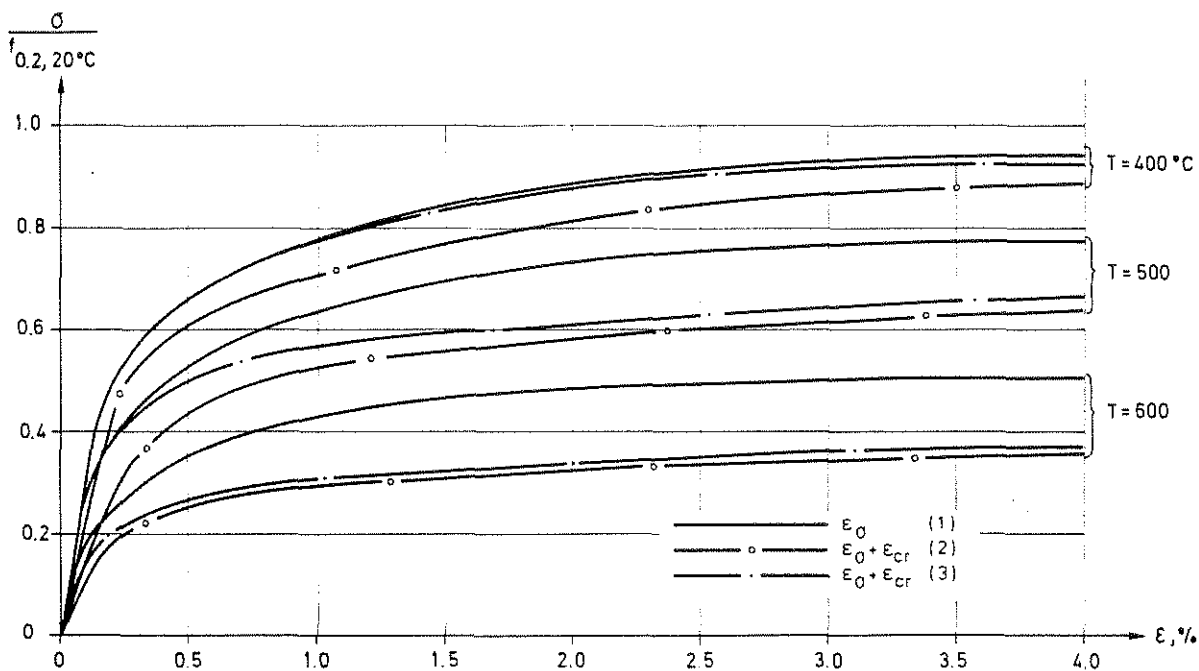

Fig. 14 Measured and predicted σ - ϵ curves from steady state and transient state tests, Anderberg (1983) /3/
 1. Steady state test, stress-controlled, $\dot{\sigma}=3.5$ MPa/s
 2. Transient state test, constructed curve, $\dot{T}=10^\circ\text{C}/\text{min}$
 3. Transient process, curve derived analytically, $\dot{T}=10^\circ\text{C}/\text{min}$

When using constructed σ - ϵ curves for design one obtains somewhat conservative values which are thus on the safe side. In an analytical study of fire-exposed structures it is often too approximate to use the simplified model because the real temperature and stress history is not accounted for. The influence of creep on the deformation behaviour for a fire-exposed steel beam is illustrated in Fig. 15. The studied case illustrates creep failure under fire attack. If creep is not considered the collapse time is increased from about 17 to 20 min and the failure temperature from 700 to 760°C.

For fire-exposed slender steel columns the influence of creep can be furthermore pronounced.

The principal importance of the stress history on the total strain in a transient process, where the rate of heating \dot{T} is constant, is illustrated in Fig. 16. Curve 1 corresponds to a constant stress σ_0 during heating up to temperature T_2 and curve 2 to a stress $\sigma_0/2$ up to temperature T_1 and then a stress σ_0 until temperature T_2 is reached. The difference in total strain is due to the different stress history and a different creep strain developed during the transient process.

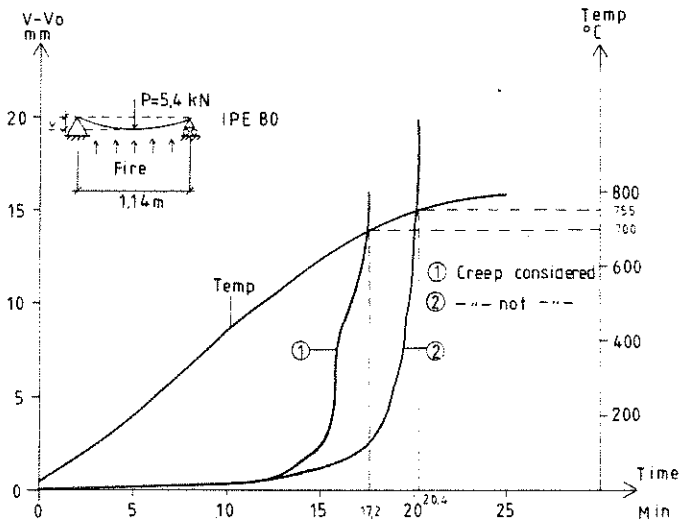

Fig. 15 Predicted deflection of fire-exposed simply supported beam.

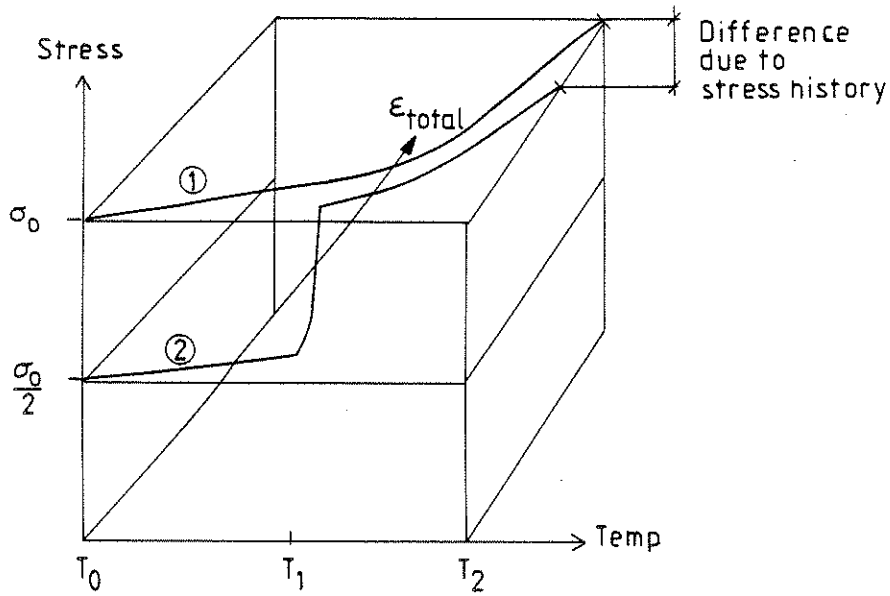

Fig. 16 Principal influence on total strain at different stress histories at a transient process.

Curve 1: $\sigma = \sigma_0$

$$T_0 \leq T \leq T_2$$

Curve 2: $\sigma = \sigma_0 / 2$
 $\sigma = \sigma_0$

$$T_0 \leq T \leq T_1$$

$$T_1 \leq T \leq T_2$$

REFERENCES

1. Anderberg, Y., Fire-Exposed Hyperstatic Concrete Structures - An Experimental and Theoretical Study. Division of Structural Mechanics and Concrete Construction, Lund Institute of Technology. Bulletin 55, Lund 1976.
2. Anderberg, Y., Mechanical Properties of Reinforcing Steel at Elevated Temperatures (Armeringsståls mekaniska egenskaper vid höga temperaturer). In Swedish with an English summary. Tekniska Meddelanden Nr. 36, Halmstad Järnverk AB, Lund 1978.
3. Anderberg, Y., Predicted Fire Behaviour of Steels and Concrete Structures. Division of Building Fire Safety and Technology, Lund Institute of Technology, Lund 1983.
4. Dorn, J.E., Some Fundamental Experiments on High Temperature Creep. Journal of the Mechanics and Physics of Solids, Vol. 3, p. 35. London 1954.
5. Dounas, S.; Golrang, B., Mechanical Properties at High Temperatures - Further Development of Steel Behaviour Model (Ståls mekaniska egenskaper vid höga temperaturer). In Swedish. Division of Building Fire Safety and Technology, Lund Institute of Technology, Lund 1982.
6. Furumura, F. et al, Nonlinear Elasto-Plastic Creep Behaviour of Structural Steel under Continuously Varying Stress and Temperature. Journal of Structural and Construction Engineering, No. 353, July 1985.
7. Harmathy, T.Z., Deflection and Failure of Steel Supported Floors and Beams in Fire. ASTM No. 422, 1967.
8. Harmathy, T.Z.; Stanzak, W.W., Elevated Temperature Tensile and Creep Properties of Some Structural and Prestressing Steels. National Research Council of Canada, Research Paper No. 424, Ottawa 1970.
9. Magnusson, S.E., Structural Behaviour and Loadbearing Capacity of Fire-Exposed Steel Columns. Safety Problem of Fire-Exposed Steel Structures (Stålpelares verkningssätt och bärförmåga vid brand. Säkerhetsproblemet vid brandpåverkade stålkonstruktioner). In Swedish. Division of Structural Mechanics and Concrete Construction, Lund Institute of Technology, Lund 1974.
10. Ramberg, W.; Osgood, W., Description of Stress-Strain Curves by Three Parameters. NACA Technical Note No. 902, 1943.
11. RILEM 44-PHT: Anderberg, Y., Behaviour of Steel at High Temperatures. February 1983.
12. Ruge, J.; Winkelmann, O., Deformation Behaviour of Reinforcing and Structural Steel at High Temperatures. Sonderforschungsbereich 148, Brandverhalten von Bauteilen, Arbeitsbericht 1978, 80 pp. 147-192.

Part II, Braunschweig, June 1980.

13. Skinner, D.H., Measurement of High Temperature Properties of Steel. Melbourne Research Laboratories (MRL 6/10), May 1972.
14. Stirland, C., Steel Properties at Elevated Temperatures for Use in Fire Engineering Calculations. Document ISO/TC92/WG15, No. 14, September 1980.