



LUND UNIVERSITY

Activated Sludge Dynamics I

Biological Models

Olsson, Gustaf

1975

Document Version:

Publisher's PDF, also known as Version of record

[Link to publication](#)

Citation for published version (APA):

Olsson, G. (1975). *Activated Sludge Dynamics I: Biological Models*. (Research Reports TFRT-3121). Department of Automatic Control, Lund Institute of Technology (LTH).

Total number of authors:

1

General rights

Unless other specific re-use rights are stated the following general rights apply:

Copyright and moral rights for the publications made accessible in the public portal are retained by the authors and/or other copyright owners and it is a condition of accessing publications that users recognise and abide by the legal requirements associated with these rights.

- Users may download and print one copy of any publication from the public portal for the purpose of private study or research.
- You may not further distribute the material or use it for any profit-making activity or commercial gain
- You may freely distribute the URL identifying the publication in the public portal

Read more about Creative commons licenses: <https://creativecommons.org/licenses/>

Take down policy

If you believe that this document breaches copyright please contact us providing details, and we will remove access to the work immediately and investigate your claim.

LUND UNIVERSITY

PO Box 117
221 00 Lund
+46 46-222 00 00

TFRT- 3121

ACTIVATED SLUDGE DYNAMICS I
Biological models

GUSTAF OLSSON

Report 7511(C) April 1975
Lund Institute of Technology
Department of Automatic Control

TILLHÖR REFL. BIBLIOTEKET

UTLÅNAS EJ

ACTIVATED SLUDGE DYNAMICS I
BIOLOGICAL MODELS

Gustaf Olsson

ABSTRACT

Dynamical models of an activated sludge system are presented. They include biological activities for organic and nitrogenous waste degradation. Mass balance equations are formulated for different configurations of aerators. Solids-liquid separation dynamics is also discussed.

ACTIVATED SLUDGE DYNAMICS I
BIOLOGICAL MODELS

Content

1. Introduction
2. Microorganisms in wastewater
 - 2.1 Classification
 - 2.2 Bacteria
 - 2.3 Autotrophic and heterotrophic organisms
 - 2.4 Aerobic and anaerobic bacteria
 - 2.5 Fungi
 - 2.5 Protozoa
 - 2.7 Biological flocculation
3. Metabolism
 - 3.1 Synthesis
 - 3.2 Respiration
 - 3.3 Nitrogen transformations by bacteria
 - 3.4 Oxygen demand
4. Biological mechanisms in the aerator
 - 4.1 Biosorption
 - 4.2 Synthesis of microorganisms
 - 4.3 Decay of microorganisms
 - 4.4 Dissolution of cell mass
 - 4.5 Numerical values of kinetic constants
5. Dynamics of a complete mix aerator
 - 5.1 Sludge bacteria
 - 5.2 Dispersed bacteria
 - 5.3 Ciliated Protozoa
 - 5.4 Inert microorganisms
 - 5.5 Organic substrate
 - 5.6 Stored mass
 - 5.7 Summary of the dynamics with constant compaction ratio in the settler

6. Dynamics of a step loaded aerator
 - 6.1 Hydraulic mass balances
 - 6.2 Concentration equations
 - 6.3 Special plant configurations
 - 6.4 Special case 1: plug flow reactor
 - 6.5 Special case 2: plug flow reactor with dispersion
 - 6.6 Special case 3: contact stabilization
7. Dissolved oxygen dynamics
 - 7.1 Aeration of water
 - 7.2 Oxygen consumption due to cell synthesis
 - 7.3 Oxygen consumption due to respiration
 - 7.4 Oxygen mass balances
8. Settler dynamics
 - 8.1 Mass balances
 - 8.2 Empirical results
 - 8.3 Dynamic models

References

Appendix: List of symbols

1. INTRODUCTION

The purpose of this report is to derive and present dynamical models of the different biological and physical phenomena which take place in an activated sludge system. The models are only formulated and no analysis or simulation is presented in the report. This will be the topic for forthcoming reports in the same series. The present report is part of a research program concerning control of wastewater treatment plants. It has previously been reported in Olsson et al (1973) and Olsson (1974).

The activated sludge process is one of the major units in a wastewater treatment plant. In the process a waste, usually domestic sewage, is stabilized biologically in a reactor under aerobic conditions. The aerobic environment is achieved by the use of diffused or mechanical aeration. After the waste have been treated in the reactor (or aerator) the resulting biological mass is separated from the liquid in a settling unit, see figure 1.1. A portion of the settled biological solids is recycled and the remaining mass is wasted as sludge. A portion of the microorganisms must be wasted; otherwise the mass of microorganisms would keep increasing until the system could no longer contain them.

The microorganisms play a key-role in the activated sludge dynamics. In the process the bacteria are the most important microorganisms because they are responsible for the decomposition of the organic material in the influent. In the reactor a portion of the organic waste matter is used by bacteria to obtain energy into new cells.

While the bacteria are the microorganisms that actually degrade the organic waste in the influent, the metabolic activities of other microorganisms are also important in the activated sludge system. For example, Protozoa consume dispersed bacteria that have not flocculated and acts therefore as effluent polisher.

It is not only important that the bacteria decompose the organic waste as quickly as possible. It is also important that the bacteria form a floc which can settle satisfactorily in the sedimentation

unit. It has been observed, that the cell age is an important parameter to determine the settling properties. Therefore a major control problem is to keep the proportions between food and microorganisms at a suitable level.

The report is organized as follows. In chapter 2 and 3 some basic properties of microorganisms and their metabolism are summarized. The biological mechanisms are then described quantitatively in chapter 4. The equations for biological growth and decay are inserted into mass balance equations for a well mixed reactor in chapter 5. In chapter 6 the equations are generalized to a more complex plant configuration, and some other existing configurations are discussed. The oxygen balance is essential in all aerobic treatment, and the oxygen dynamics is described in chapter 7. In chapter 8 the settler properties are discussed in some detail.

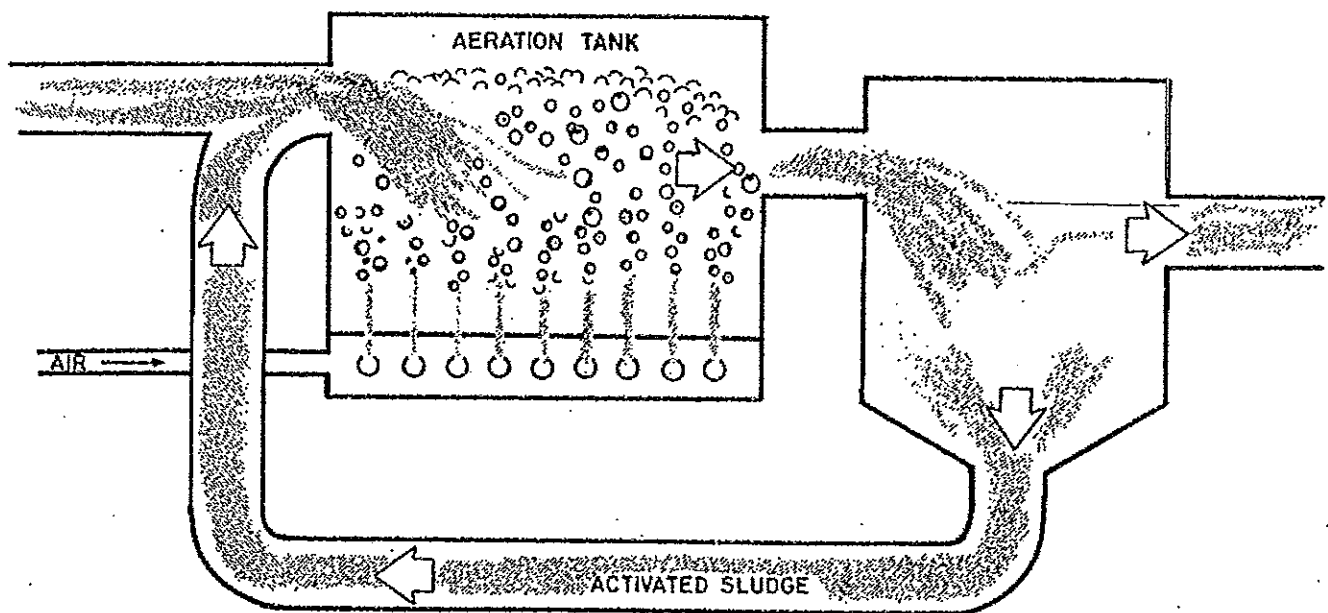

Fig. 1.1. The activated sludge system.

2. MICROORGANISMS IN WASTEWATER

A majority of chemical reactions occurring in water, particularly those reactions involving organic matter, are mediated by microorganisms. Microorganisms play a dominant role in biological waste treatment. Although aquatic microorganisms are of extreme importance for water purification as well as health and disease, we shall consider only the role which they play in wastewater chemical transformations. In order to make the control engineer somewhat familiar with the basic phenomena of biological treatment systems, microorganisms and their metabolism will be described superficially in this chapter and in chapter 3.

There is a large number of standard textbooks available covering the material, presented in chapters 2 and 3.

The microbial population in wastewater is described in some sanitary engineering textbooks, such as Rich (1973), Fair et al (1968), Metcalf & Eddy (1972). Other books are Hawkes (1963), McKinney (1962). The books by Stainer et al (1958), Oginsky et al (1959), Gunsalus et al (1962) and Lamanna et al (1965) cover a wider range of the microbial metabolism. Also Einsele et al (1971) present a good introduction into the problems of metabolism and transport phenomena. Some of the basic thermodynamics involved in the metabolism reactions is described in Manahan (1972). The report by Hilmer et al (1964) gives a good survey of the topic (in Swedish).

2.1 Classification

The organisms in wastewater can be classified in many different ways. Here we consider the types algae, fungi, bacteria and protozoa.

Algae are classified as producers, because they use light energy and store it as chemical energy. In the absence of sunlight, however, algae utilize chemical energy for their metabolic needs.

Algae can therefore be considered as aquatic "solar fuel cells". Algae will not be considered further in the activated sludge modelling, as the photosynthesis can be neglected in comparison with other phenomena in the process.

Fungi, bacteria and protozoa (except photosynthetic bacteria) are classified as reducers. Reducers break down chemical compounds to more simple species. They thereby extract the energy needed for their growth and for their metabolic needs. Reducers can use only chemical energy. Therefore any chemical transformation mediated by them must involve a net loss of free energy. In a sense fungi, bacteria and protozoa can be considered as environmental catalysts.

2.2 Bacteria

Bacteria may be shaped as rods, spheres, or spirals. They may occur individually, or grow as groups ranging from two to millions of individual cells. Individual bacterial cells are very small and may be observed only through a microscope. Most bacteria fall into the size range of 0.5 to 3.0 microns. However, considering all species, a size range of 0.3 microns to 50 microns is observed.

The metabolic activity of bacteria is greatly influenced by their small size. Since bacterial cells are so small, their surface to volume ratio is extremely large. Therefore, the inside of a bacterial cell is highly accessible to a species in its surrounding medium. Thus bacteria may bring about very rapid chemical reactions compared to larger organisms, for the same reason that a finely divided catalyst is more efficient than a more coarse one.

Bacterial cells have a number of separate components, see fig.2.1. Some cells are surrounded by a slime layer. The layer immediately inside the cell wall is the cytoplasmic membrane, which controls

the nature and quantity of materials transported into and out of the cell. The inside of the cell is filled with cytoplasm, the medium in which the cell's metabolic processes are carried out. The nucleus is the "control center" of the cell, and controls metabolic processes and reproduction. In addition to the above features, the cell may contain "inclusion" of reserve food material consisting of fats, carbohydrates, and even elemental sulfur. Some bacteria possess movable flagella. These hair-like appendages give the bacteria mobility.

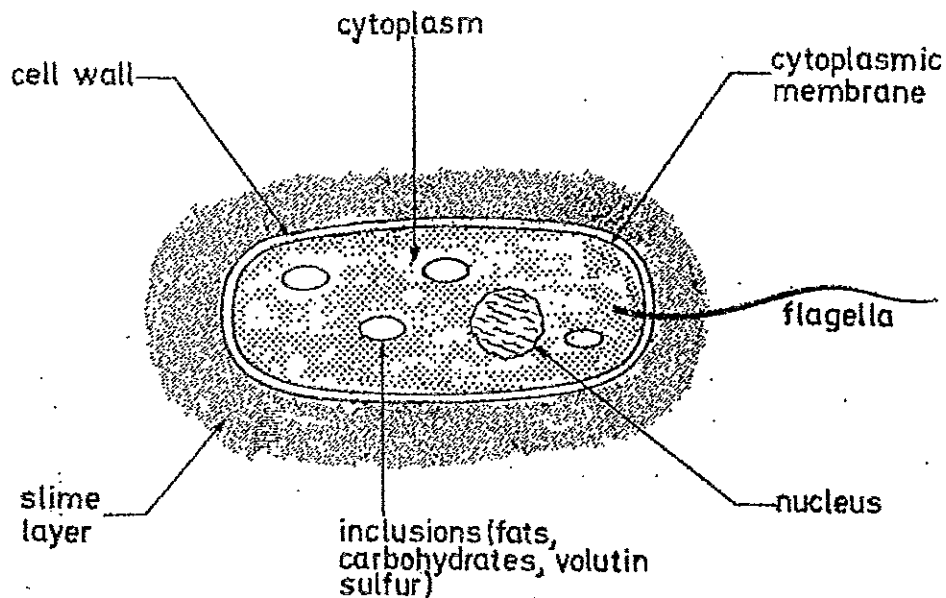

Fig. 2.1 Schematic diagram of bacterial cell structure.

Although individual bacterial cells are invisible to the naked eye, visible bacterial colonies arising from individual cells are readily visible. A common method of "counting" individual bacterial cells in water consists of spreading a measured volume of the water on a plate of agar gel containing bacterial nutrients. Wherever a viable bacterial cell adheres to the plate, a bacterial colony consisting of many cells will grow. These bacterial colonies

then are counted and related to the number of cells present initially.

Temperature and pH play a vital role in the life and death of bacteria, as well in other microscopic plants and animals. It has been observed that the rate of reaction for microorganisms increases with increasing temperature, doubling with about every 10° C of rise in temperature until some limiting temperature is reached. Bacteria may be classified according to the temperature range in which they function best. The pH of a solution is also a key factor in the growth of organisms. Most organisms cannot tolerate pH above 9.5 or below 4.0. Generally the optimum pH for growth lies between 6.5 and 7.5.

Examinations of different bacteria populations in different environments have shown, that the bacteria consist of about 80 % water and about 20 % dry matter.

About 90 % of the dry matter is organic and about 10 % is inorganic. The organic part of the bacteria use to be described by the empirical formula $C_5H_7O_2N$.

2.3 Autotrophic and heterotrophic organisms

Bacteria may be classified in different ways, e.g. into the two main categories

- autotrophic bacteria

- heterotrophic bacteria

Autotrophic organisms in general utilize solar energy to fix elements from simple, non-living, inorganic material to the proteins and other complex molecules composing living organisms. Thus autotrophic bacteria are not dependent upon organic matter

for growth, and may thrive in a completely inorganic medium. They may use carbon dioxide or other carbonate species as a carbon source. Autotrophic bacteria may use a number of different energy sources, depending in the species of bacteria. Nitrosomonas and Nitrobacter (see 3.3) are typical autotrophic bacteria.

In wastewater treatment heterotrophic bacteria are the most important. They use organic substances as their energy source and as the raw materials for the synthesis of their own biomass. Heterotrophic bacteria are the microorganisms primarily responsible for the breakdown of pollutant organic matter in waters and of organic wastes in biological waste treatment processes (see further 3.1, 3.2).

Algae are autotrophic organisms using CO_2 as a carbon source and light as an energy source. Fungi are entirely heterotrophic, deriving carbon and energy from the degradation of organic matter.

2.4 Aerobic and anaerobic bacteria

The bacteria can also be classified upon the basis of their requirement for molecular oxygen. Aerobic bacteria require oxygen as an electron acceptor

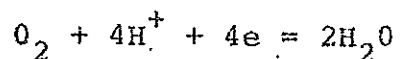

Anaerobic bacteria function only in the complete absence of molecular oxygen. Molecular oxygen can be toxic to anaerobic bacteria.

In the present paper we focus upon the aerobic environment in an activated sludge process. If the supply of oxygen is limited, however, then oxygen depletion may occur with the subsequent development of nuisance conditions fostered by anaerobiosis.

When organic materials containing carbon, nitrogen and sulfur are decomposed, the inorganic products developed in aerobic and anaerobic environments are as follows:

	Aerobic	Anaerobic
organic C	CO_2	CO_2, CH_4
organic N	NO_3^-	NH_3
organic S	SO_4^{--}	H_2S

The conversion of organic materials to inorganics requires a hydrogen acceptor. In an aerobic environment, microorganisms utilize molecular oxygen for this purpose. In an anaerobic environment they utilize sulfates, nitrates, carbon dioxide and organic compounds.

2.5 Fungi

Fungi are non-photosynthetic organisms. Most frequently they possess a filamentous structure. The morphology (structure) of fungi covers a wide range. Some fungi are as simple as the microscopic unicellular yeasts, whereas other fungi form large, complicated toadstools. The microscopic filamentous structures of fungi generally are much larger than bacteria and usually are 5 to 10 microns in width. Fungi are aerobic organisms and generally may thrive in more acidic media than bacteria. They are also more tolerant of higher concentrations of heavy metal ions than are bacteria.

Fungi have also a low nitrogen requirement, about half of that of bacteria. The ability of fungi to survive under low pH and nitrogen limiting conditions makes them important in the biological treatment of some industrial wastes.

The organic part of the cell mass has the empirical formula $\text{C}_{10}\text{H}_{17}\text{O}_6\text{N}$. The nitrogen content is thus lower than in bacteria.

2.6 Protozoa

In biological wastewater treatment not only bacteria and fungi occur but also different species of single cell organisms, which could be called aquatic animals. The Protozoa family is the most important representative of those animals. Protozoa are generally an order of magnitude larger than bacteria and often consume dispersed bacteria as an energy source. In effect, the Protozoa act as polishers of the effluents from biological waste treatment processes by consuming bacteria and particulate organic matter. The chemical composition of the protoplasm is believed to be $C_7H_{14}O_3N$.

Protozoa can be split up in different classes. One type of classification follows here.

- 1). Amebiod protozoa (Sarcodina). These extremely simple animals are irregular in shape, naked or shelled, single or colonial. They are characterized by their pseudopods or false feet, which they use for movement and the capturing of food.
- 2). Flagellated Protozoa (Flagellata or Mastigophora). The Flagellates possess flagella, which they use for their motility. They occur singly or in colonies, naked or in cellulosic shells. They can be heterotroph or autotroph.
- 3). Ciliated Protozoa. (Ciliata or Infusoria). The Ciliated Protozoa group is considered the most important group in the Protozoa family in wastewater treatment. Movements by means of cilia is characteristic of these Protozoa. The cilia are hairlike extensions from the cell membrane, used for both food capture and cell mobility. Sanitary engineers usually consider the Ciliata to be divided into two types, the free-swimming and the attached. The free-swimming type must swim after bacteria. They require a great deal of food, because they expend so much energy in swimming. One type of free-swimming Ciliates is Paramecium. The attached Cili-

ates are attached to something solid and must catch their food as it passes by. Because their movement is limited, they require less food for energy. The Vorticella is a stalked Ciliate that is important in biological treatment processes, especially in the activated sludge process. Generally the Ciliates are strictly aerobic.

4). Suctoria. The Suctoria are Protozoa that have long tentacles, which they use to capture other Protozoa and then draw the protoplasm of these Protozoa into their own bodies. During the early stage of their life cycle the Suctoria have cilia, but later in the adult stage they obtain their tentacles.

2.7 Biological flocculation

A special requirement for most biological processes used in wastewater treatment is the production of flocculant microorganisms that can be easily separated from the liquid stream in a concentrated form by such physical processes as gravity sedimentation, centrifugation or vacuum filtration. From a pollution control point of view the microorganisms produced must also be considered as an undesirable product, since, being organic matter, they can place a pollutional burden on the receiving waters. Ease of separation from the liquid phase and self-destruction of the microorganisms through autooxidation are therefore of considerable importance.

McKinney (1963) showed that flocculation can be related to the ratio food-to-microorganisms. He showed that under certain conditions the organisms normally present in an activated sludge unit flocculated rapidly under starvation conditions. Other authors, e.g. Anderson (1963) have shown that flocculation results from a slime layer, built up by sticky Polysaccharides. Organisms can then adhere to this layer. The slime formation does not occur during large food-to-microorganism ratios and requires excess carbohydrates, see Eckenfelder (1966).

Because of the settling properties not all microorganisms are desired in an activated sludge unit. Because of their high surface area/volume ratio filamentous organisms (such as free-swimming Ciliated Protozoa) may survive better under low oxygen tensions than other flocculated aerobic organisms. Under those conditions non-settling flocs can result.

A good settling sludge must have high density. Bulking sludge can be a result of the growth of e.g. Fungi and other filamentous forms. Their growth is stimulated by aerobic conditions and an available carbon source.

The settling of activated sludge is further considered in chapter 8.

3. METABOLISM

Living matter is distinguished from non-living organic materials by its metabolism. Metabolism is defined as the chemical and physical processes continuously taking place in living organisms and cells. Assimilated nutrients can be built up into protoplasm (anabolism) and protoplasm can be used and broken down into simpler substances with the release of energy (catabolism). The overall metabolism of bacterial cells can be thought of as consisting of two biochemical reactions: energy and synthesis. The first reaction releases energy so that the second reaction of cellular synthesis can proceed. Each reaction is a result of a long series of enzyme-catalyzed reactions. The discussion that follows is centered around the bacteria, but the basic principles are applicable for all living cells.

3.1 Synthesis

Cell synthesis takes place when the organism uses e.g. organic wastes as food. In the process complex organics are broken down into simple organics and inorganic materials. As the synthesis requires energy it is an anabolic process. The cell synthesis in an activated sludge process is aerobic, so oxygen is consumed. Therefore the general form of the synthesis reaction is

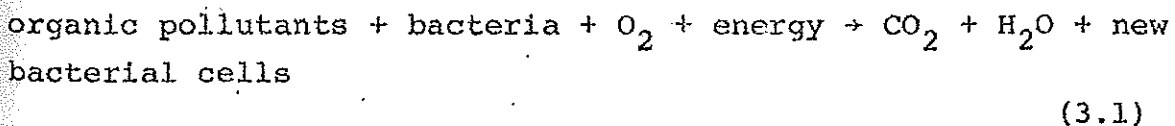

The reaction can take place only if energy is added. In most cases there are heterotrophic bacteria acting, and therefore the energy is taken as the free energy, bounded chemically.

3.2 Respiration

Organisms derive energy for their synthesis from organic materials

in a process called respiration:

External substrate \rightarrow metabolic products + energy.

Respiration is an oxidation process, requiring a hydrogen acceptor. Molecular oxygen serves as a hydrogen acceptor for aerobic organisms.

The metabolic products resulting from respiration are inorganic compounds of carbon, nitrogen and sulfur. Respiration releases energy contrary to the synthesis and is consequently complementary to the synthesis in metabolism. Therefore synthesis in heterotrophic organisms must always be followed by respiration. The energy transfer from respiration to synthesis is carried by a chemical compound Adenosine Triphosphate (ATP). The energy captured by this compound is used for cell synthesis, life maintenance and motility. When the ATP molecule has expended its captured energy to the reactions involved in cell synthesis and maintenance, it changes to a discharged state called Adenosine Diphosphate (ADP). This ADP molecule can then capture the energy released in the breakdown of organic or inorganic matter. Having done this, the compound again assumes an energized state as the ATP molecule. The ADP-ATP cellular energy system enables the chemical reaction comprising respiration and synthesis to be carried out at the relatively low temperatures characterizing metabolic processes. The ATP-ADP mechanism also points to the importance of phosphates to living organisms.

The respiration can be represented by the reaction formula

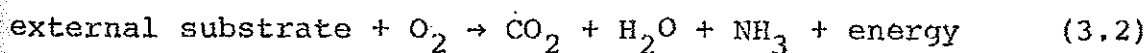

In absence of suitable external substrate it can be obtained through catabolic degradation of the internal cellular materials themselves. Such a process, called endogeneous respiration may be represented by

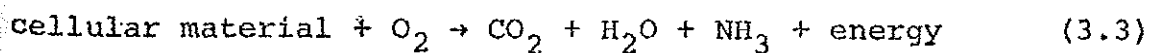

The endogeneous respiration is therefore an oxygen consuming reaction, where the cells undergo a decay. The metabolic products and energy transfer mechanism are the same in endogeneous respiration and the so called primary respiration, represented by (3.2).

The amount of oxygen which would be required for complete oxidation of the organic material varies with the nature of the compounds present. One quantitative measure of the relative amounts of oxygen required is the respiratory quotient (RQ) which is based upon the relative amounts of CO_2 (totally oxidized carbon) which can be produced from different classes of organic compounds by use of the same amount of O_2 . The RQ, moles CO_2 produced per mole O_2 used, is 1.0 for carbohydrates, 0.8 for proteins and 0.7 for fats. For a waste containing primarily carbohydrates which can be represented as CH_2O the balanced equation for oxidation (RQ=1) can be written



3.3 Nitrogen transformations by bacteria

The aerobic biological degradation of organic material is the primary interest in this paper. In order to complete the text for further model developing also nitrogen removal will be considered. Ammonia is the most important inorganic compound that have an oxygen demand on the water. If ammonia is present in the effluent water then the dissolved oxygen content in the receiving stream can be lowered through the process of nitrification. In this process ammonia is biologically oxidized to nitrite. The nitrite is then oxidized by another group of microorganisms to nitrate. Nitrate is the final oxidation state of the nitrogen compounds, and as such represents a stabilized product.

For the removal of nitrogen in the biological treatment the

nitrification-denitrification process appears to be the most promising. Nitrogen in the form of the ammonium ion is converted to nitrate in two steps, called nitrification. Nitrification is catalyzed by two groups of bacteria, Nitrosomonas and Nitrobacter. Nitrosomonas bacteria bring about the transition of ammonia to nitrite,

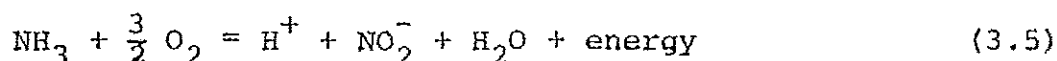

whereas Nitrobacter mediate the oxidation of nitrite to nitrate:



The overall nitrification reaction is then

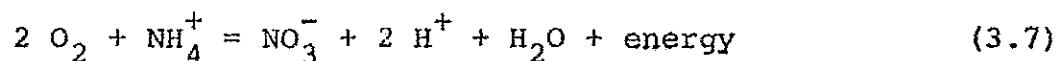

Both of these highly specialized types of bacteria are aerobes, i.e. they function only in the presence of molecular oxygen. The bacteria are also autotrophic meaning that they can utilize CO_2 as a carbon source in the synthesis of their biomass.

If nitrification is to be accomplished in an activated sludge system certain operational conditions must be satisfied. First, additional oxygen must be added. Then a longer mean cell residence time must be used compared to heterotrophic bacteria. The nitrifying bacteria have a growth rate that is much lower than that of heterotrophic bacteria, and therefore they require a longer cell residence time to be effective, of the order 10 days or more.

Denitrification is an important process in nature. It is the mechanism by which fixed nitrogen is returned to the atmosphere. Denitrification is also becoming an important process in advanced water treatment for the removal of nutrient nitrogen. The water is treated with a minimum amount of methanol under anaerobic conditions, and N_2 gas is evolved according to the following

reaction:

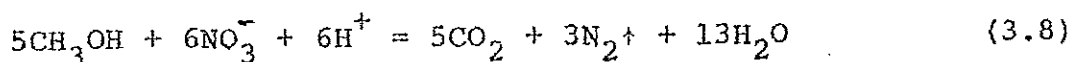

Because nitrogen gas is a non-toxic volatile substance which does not inhibit microbial growth, and since nitrate ion is a very efficient electron acceptor, denitrification allows the extensive growth of bacteria under anaerobic conditions.

3.4 Oxygen demand

Oxygen is a vital component both for cell synthesis and respiration, see 3.1 and 3.2. Unless the water is reaerated efficiently it rapidly becomes depleted in oxygen and will not support higher forms of aquatic life. Oxygen may also be consumed in water by the biooxidation of nitrogenous material according to eq (3.7) and by chemical and/or biochemical oxidation of chemical reducing elements; e.g.

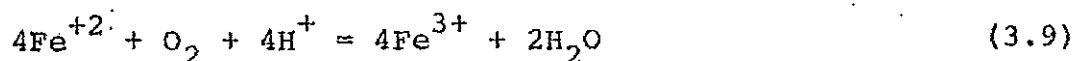

The parameter Biochemical oxygen demand (BOD) is a measure of the microbially-mediated oxygen consumption by contaminants in water. The amount of oxygen required for oxidation of organic material can be calculated by stoichiometric formulas of the type (3.1) where the cell mass is represented by organic molecules of the type $\text{C}_a\text{H}_b\text{O}_c\text{N}_d\text{P}_e\text{S}_f$, see e.g. Rich (1973). Generally BOD represents the amount of BOD utilized.

Consider fig. 3.1, which qualitatively describes the oxygen utilized in water containing a flora of microorganisms and nutrients. The curves consist of two different stages. In an activated sludge system the first stage is the most important one, and it extends over several days. The first stage is inter-

preted as resulting from oxidization of the carbon in the organic materials being decomposed. The second stage is considered to reflect the oxygen utilized in the oxidation of the nitrogen compounds, the nitrification, see 3.3. However, because of the length of time generally elapsed before the onset of the nitrification stage, the latter in many cases has been considered as having little practical significance in the standard BOD test.

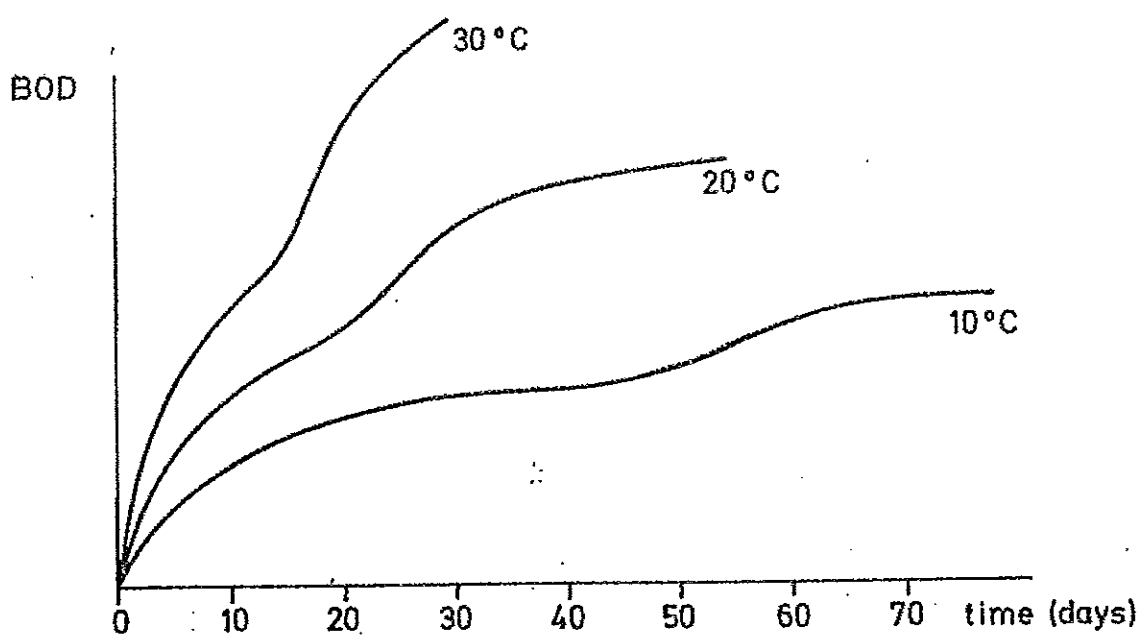

Fig. 3.1. Biochemical oxygen demand (utilized) as function of time.

The first stage BOD follows a first order reaction

$$\frac{dL}{dt} = -k_1 L \quad (3.11)$$

where L is the oxygen remaining and k_1 a constant. Thus

$$\text{BOD}(t) = \text{BOD}(t_0) (1 - e^{-k_1 t}) \quad (3.12)$$

The value $k_1 = 0.23$ (days⁻¹) at 20°C can be used as an average value in domestic waste.

The BOD parameter is commonly measured by the quantity of oxygen

utilized by suitable aquatic organisms during a five day period (BOD_5) or a seven day period (BOD_7). The limiting value for infinite time is called the ultimate BOD (BOD_u). Normally the BOD_u does not include the nitrification stage.

Considering the time frame of the curves in fig 3.1 one has to conclude that these BOD curves for most part reflect the endogenous respiration. The more rapid synthesis may take place only during the first few hours at the most.

For control purposes it is completely unrealistic to use the BOD as a measurement variable of the biodegradable content, as it takes several days to get the value. The chemical oxygen demand, COD, is a much more easily determined parameter. Basically the test consists of the chemical oxidation of material in water by dichromate ion in 50% H_2SO_4 :

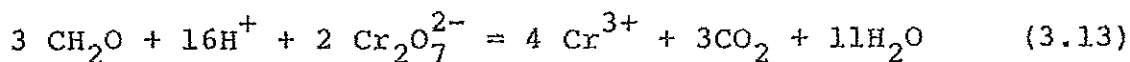

After the oxidation of the oxidizable material in water, the amount of unreacted dichromate is determined by titration with a standard reducing agent.

The COD of a water may differ appreciably from the BOD. The presence of poorly biodegradable compounds in water will result in a COD higher than the BOD. In some cases the BOD may be lower than the BOD. For a specific plant it is often possible to establish a fair correlation between COD and BOD. For typical domestic wastes the BOD/COD ratio vary from 0.4 to 0.8.

It is common practice to measure the concentrations of different microorganisms and substrates in terms of their oxygen equivalents. Thus the concentration 1 mg/l of organic waste means, that there is 1 mg demand of oxygen in a liter of water to completely oxidize the substrate (Total oxygen demand TOD). Biodegradable organics have oxygen demand expressable in BOD. There

is also non-biodegradable materials with oxygen demand. The total oxygen demand TOD is one measure of the concentration too, see Clifford (1967). Here all concentrations will be expressed in TOD. The corresponding COD is about 0.8 times the TOD value and BOD_u about 0.7 times the TOD.

Also the organism (viable and non-viable) concentration can be expressed in oxygen equivalents. Stoichiometric formula can indicate the oxygen requirements for cell synthesis, respiration and decay. The concentration of viable and non-viable organisms will therefore be expressed in TOD as well.

4. BIOLOGICAL MECHANISMS IN THE AERATOR

The activated sludge system is a very special aquatic unit. Due to the turbulence and the circulation of the sludge the conditions are quite different to those of a natural stream.

In this chapter the microbial metabolism will be more quantitatively described for an activated sludge system. Fig. 4.1 gives a sketch of the microbial transformations of organic waste in an activated sludge system. One link of the microbial chain at a time will be considered, and a quantitative description of the transformations will be suggested.

In 4.1 the first contact between the organic pollutant and the microorganisms is described, the so called biosorption. The synthesis of organisms is discussed in 4.2 and the decay in 4.3. The dissolution of cell material to substrate is mentioned in 4.4. In 4.5 some numerical values for kinetic constants are given.

4.1 Biosorption

The wastewater must contain all the necessary nutrients for the organisms in the sludge, if they should survive. When the wastewater is brought into contact with the organisms a number of initial mechanisms take place. Before the organisms can use the substrate as a food source it has to penetrate the cell membrane by a purely physico-chemical process. This transfer occurs by several mechanisms which include adsorption, absorption and physical entrapment. This biosorption does not include any biological oxidation, and takes place within an hour. The biosorption process is made use of intentionally in the contact stabilization process, see 6.6.

It could be observed in any wastewater treatment plant that it is a rapid initial removal of organic pollutants. As an example a step disturbance in organic load very rapidly damped out. Jones (1971) has described this process as a transfer of substrate from

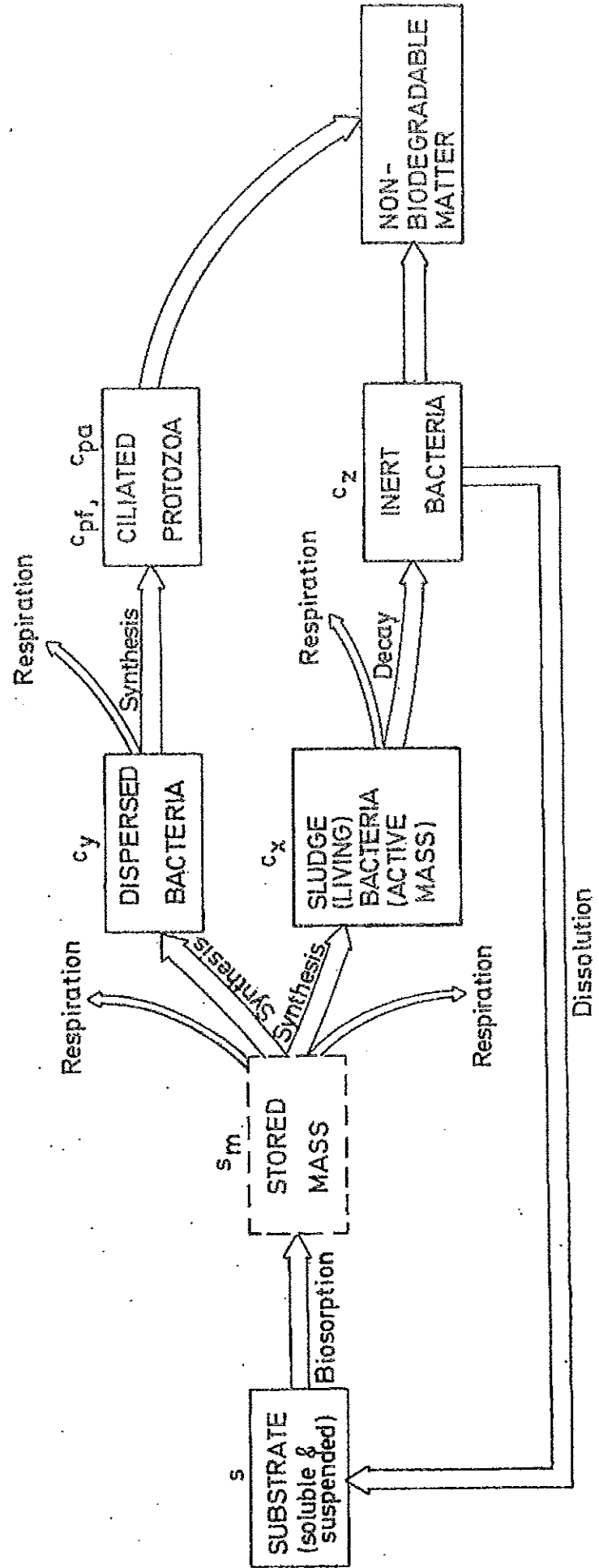

Fig. 4.1 Schematic picture of the microbial interactions.

the liquid phase to the floc phase.

The mechanism is described here in one equation, when either suspended or colloidal biodegradable organic materials are transferred to the bio-floc. Blackwell (1971) has suggested this transfer mechanism as a driving force

$$\frac{ds_m}{dt} = r_s c_T \left[\hat{f}_s \frac{s}{K_s + s} - f_s \right] \quad (4.1)$$

$$\frac{ds}{dt} = - \frac{ds_m}{dt} \quad (4.2)$$

where

s_m = concentration of stored mass

c_T = concentration of total mixed liquor volatile suspended solids (MLVSS) in the aerator, i.e. c_T is the sum of the concentrations of stored mass, microorganisms, both viable and non-viable.

\hat{f}_s = the maximum fraction of stored mass, that can be incorporated in the total MLVSS

f_s = fraction of MLVSS that is stored mass, i.e. $f_s = s_m/c_T$

r_s = transfer rate constant (h^{-1})

s = substrate concentration

K_s = adsorption - absorption coefficient.

The expression has been used by Busby (1973). The transfer mechanism has also been studied by McLellan (1969), Walters (1966) and Morris - Stumm (1960).

As the transfer of substrate into the biological floc is dependent of the substrate concentration, also the storage capacity in the

biological floc depends on the substrate concentration. As the biosorption is a rapid process, it can also be assumed that equilibrium could prevail between stored mass and liquid substrate.

Neame and Richards (1972) have considered the problems of membrane carrier transport, which can be applied in this context. They assume the model, that substrate is adsorbed at one side, moved across the membrane and released at the other. The simplest equation which describes the carrier transport phenomenon is the Michaelis-Menten equation

$$v = \frac{v_{\max} s}{K_m + s}$$

where s = substrate concentration

v_{\max} = maximum transport rate

v = transport rate

K_m = saturation constant

Diffusion may contribute to transfer. The total rate of transfer is then the sum of the separate rates, thus

$$v = \frac{v_{\max} s}{K_m + s} + K_D \cdot s$$

where the last term is the diffusion term.

Now the rate of carrier transport in each direction (v_{in}) and (v_{out}) is expressed as

$$v_{in} = \frac{v'_{\max} s}{s + K'_s} \quad v_{out} = \frac{v''_{\max} s_m}{s_m + K''_s}$$

where s = soluble and colloidal substrate outside the cell

s_m = stored mass in the cell

Thus the net transfer, including diffusion, can then be expressed as

$$v_{net} = v_{in} - v_{out} = \frac{v'_{\max} s}{s + K'_s} - \frac{v''_{\max} s_m}{s_m + K''_s} + K_D (s - s_m)$$

The expression has many similarities to (4.1).

The biosorption is neglected by most authors, describing activated sludge dynamics, as it is very rapid. Even if the dynamics of the process could be neglected compared to the cell synthesis dynamics it is very important to distinguish between stored mass and soluble and colloidal substrate. One reason is, that a COD measurement only takes the liquid substrate into consideration. Another reason is, that a contact stabilization process makes use of the biosorption mechanism (see further 6.6). No attempt is made here to distinguish between soluble and colloidal substrate. It has been observed, that the transfer mechanisms could be quite different, see e.g. Jones (1971). Here the coefficient r_s will be adjusted to fit an actual plant. Quite a complex model is suggested by Jaquart et al (1973) and Blackwell (1971). Colloidal and soluble substrate mechanisms are described by separate mechanisms and very complex models result. In order to limit the complexity we stick to the expression (4.1). Then the substrate mass balance in the aerator can be represented by just one equation. This simplification is also justified by e.g. Ford - Eckenfelder (1967) and Busby (1973).

4.2 Synthesis of microorganisms

In the model we will consider three different species of microorganisms, sludge bacteria (c_x), dispersed bacteria (c_y) and Ciliated Protozoa (c_p), see fig. 4.1. Nitrification bacteria are not included in the figure.

The sludge bacteria can be flocculated and are concentrated in the liquid-solids separator after the aerator. The dispersed bacteria are also called sewage bacteria. They are defined as those bacteria born in the sewage in considerable quantities and are able to use the soluble constituents of the wastewater. Unlike

sludge bacteria, they are not considered to flocculate. They remain in suspension in the reactor and the separator tank. The dispersed bacteria are also available as a food source to Ciliated Protozoa that may be present.

It is assumed that the microorganisms considered are heterotrophic. Therefore the synthesis equations are similar for the three types of organisms. It is assumed, that the sludge bacteria and dispersed bacteria use either substrate or stored mass as a food source. The Ciliated Protozoa use the dispersed bacteria as a food source.

4.2.1 Sludge bacteria

The growth rate of the sludge bacteria is empirically assumed to be

$$\frac{dc_x}{dt} = \mu_x \cdot c_x \quad (4.3)$$

where

c_x = sludge bacteria concentration

μ_x = specific growth rate

where the growth rate μ_x can be described by different expressions. Here we assume the Monod (1942) function for the growth,

$$\mu_x = \hat{\mu}_x \frac{s_m}{K_x + s_m} \quad (4.4)$$

If no biosorption is assumed, then the substrate is used as nutrient,

$$\mu_x = \hat{\mu}_x \frac{s}{K_x + s} \quad (4.5)$$

where $\hat{\mu}_x$ = maximum specific growth rates of the organisms (h^{-1})
 K_x = saturation constants.

Other types of growth rate terms are also suggested.

Teissier (1936) proposed

$$\mu_x = \hat{\mu}_x^{(2)} (1 - e^{-k_1 s}) \quad (4.6)$$

which is an approximation of the Monod curve. Another expression is found in Eckenfelder - McCabe (1960).

$$\mu_x = k_2 \cdot s \quad \text{for } s < s^* \quad (4.7)$$

$$\mu_x = \hat{\mu}_x^{(3)} \quad s > s^*$$

which is a straight line approximation of the Monod function (4.4). Other approximations are listed in Mikesell (1971). The function

$$\mu_x = \hat{\mu}_x^{(4)} \frac{1}{1 + \frac{K_x}{s} + \frac{s}{K_i}} = \hat{\mu}_x^{(4)} \frac{s}{s + K_x + \frac{s^2}{K_i}} \quad (4.8)$$

has an inhibitory term $\frac{s^2}{K_i}$. Especially in anaerobic digesters (Andrews (1972)) this growth term is adequate.

If stored mass is considered as the organism nutrient, then s is replaced by s_m . Some assumptions have been made implicitly in the growth equation (4.3). The most important ones are

- (i) There is enough oxygen available for the synthesis. The influence from oxygen limitation is considered in chapter 7.
- (ii) All the necessary nutrients for proper biological growth are present. The only limiting substance is the biodegradable organic matter. The pH and temperature are regulated for the proper rate of growth.

The temperature effect can be quantified due to the Arrhenius equation. If the temperature differences are small, then the equation can be approximated to

$$\hat{\mu} = \hat{\mu}_0 \cdot \theta^{(T-T_0)} \quad (4.9)$$

where $\hat{\mu}$, $\hat{\mu}_0$ = maximum specific growth rates for the temperatures T and T_0 respectively (h^{-1})

θ = temperature coefficient, ranging from about 1.03 to 1.07.

Growth and nutrient utilization are directly related. The yield of the reaction can be calculated directly from stoichiometric relations. The substrate consumption can be written proportional to the cell growth,

$$\frac{ds}{dt} = - \frac{\mu_x^1 \cdot c_x}{Y_x^1} \quad (4.10)$$

where Y_x^1 = yield factor, usually assumed constant about 0.5. In the case stored mass, then the consumption of stored mass is

$$\frac{ds_m}{dt} = - \frac{\mu_x \cdot c_x}{Y_x} \quad (4.11)$$

4.2.2 Dispersed bacteria

The growth equation for dispersed bacteria is completely analogous to that for sludge bacteria,

$$\frac{dc_y}{dt} = \mu_y \cdot c_y \quad (4.12)$$

where μ_y = specific growth rate.

The specific growth rate is assumed to be of the Monod type,

$$\mu_y = \hat{\mu}_y \cdot \frac{s_m}{K_y + s_m} \quad (4.13)$$

where $\hat{\mu}_y$ = maximum specific growth rate

K_y = saturation constant.

There is a quantitative difference between sludge and dispersed bacteria growth rate. Due to the large surface-area-to-volume ratio for dispersed bacteria, both nutrients and dissolved oxygen can much more easily penetrate into the organisms. This means that the specific growth rate is larger for the dispersed bacteria. They can also synthesize in a lower dissolved oxygen concentration. In a poor oxygen environment therefore the dispersed bacteria survive better than the sludge bacteria, thus creating a poor sludge with bad settling properties, (see also 4.5).

The nutrient consumption of the dispersed bacteria corresponding to eq (4.11) is

$$\frac{ds_m}{dt} = - \frac{\mu_y \cdot c_y}{Y_y} \quad (4.14)$$

where Y_y = yield constant, about 0.5.

The dynamics of dispersed bacteria has been studied e.g. by Curds (1971, 1973). In a recent article by Lee et al (1975) the kinetics of dispersed bacteria together with sludge bacteria has been studied.

4.2.3 Ciliated Protozoa

Two different species of Ciliated Protozoa are considered

- o free-swimming Ciliates (c_{pf})
- o attached and crawling Ciliates (c_{pa})

The free-swimming Ciliates are considered to swim freely in the mixed liquor and they are fed on the dispersed bacteria, but not on the flocculated masses of sludge bacteria. It is further assumed that they remain dispersed in the whole system and are not separated in the sedimentation unit. It is also assumed that they are not present in the influent raw wastewater.

The attached and crawling Ciliates are associated with the sludge floc. Therefore they will settle together with the sludge bacteria. It is assumed that the attached and crawling Ciliates behave in similar manner and are therefore described with one state variable. It is also assumed that they feed on the dispersed bacteria but not on the flocculated sludge bacteria.

The growth rate of the free swimming ciliates (c_{pf}) is described by

$$\frac{dc_{pf}}{dt} = \mu_{pf} \cdot c_{pf} \quad (4.15)$$

where μ_{pf} = specific growth rate for free-swimming Ciliates.

The growth rate is assumed to be of the Monod type,

$$\mu_{pf} = \hat{\mu}_{pf} \cdot \frac{c_y}{K_{pf} + c_y} \quad (4.16)$$

where K_{pf} = saturation constant

$\hat{\mu}_{pf}$ = maximum specific growth rate.

The attached Ciliates (c_{pa}) are assumed to grow similarly,

$$\frac{dc_{pa}}{dt} = \mu_{pa} \cdot c_{pa} \quad (4.17)$$

where μ_{pa} = specific growth rate for the attached Ciliates

$$\mu_{pa} = \hat{\mu}_{pa} \cdot \frac{c_y}{K_{pa} + c_y} \quad (4.18)$$

where K_{pa} = saturation constant

$\hat{\mu}_{pa}$ = maximum specific growth rate

The Protozoa consume dispersed bacteria for their synthesis and the consumption is

$$\frac{dc_p}{dt} = - \frac{\mu_p \cdot c_p}{Y_p} \quad (4.19)$$

$$\text{where } c_p = c_{pf} + c_{pa} \quad (4.20)$$

$$\mu_p = \mu_{pf} + \mu_{pa} \quad (4.21)$$

Y_p = yield constant for Protozoa growth

The Protozoa are especially sensitive to low oxygen levels in the water.

The dynamical behaviour of Protozoa has been studied e.g. by Curds (1971, 1973); Canale et al (1973), Varma et al (1975).

4.2.4 Nitrification bacteria

The nitrification bacteria Nitrosomonas and Nitrobacter are described in section 3.3. The synthesis phase of those bacteria follows the same type of growth patterns as the heterotrophic bacteria. The only difference is that the maximum growth rate and the yield coefficient are much smaller.

The substrate for the Nitrosomonas is ammonia nitrogen when new cells and nitrite are produced. Nitrobacter uses nitrite produced by the Nitrosomonas as substrate to produce new cells and nitrate.

The dynamics of the nitrification has been described by Smith - Eilers (1970) and by Poduska - Andrews (1974). The growth terms are similar to (4.2). For Nitrosomonas the growth is

$$\frac{dc_{ns}}{dt} = \mu_{ns} \cdot c_{ns} \quad (4.22)$$

where

c_{ns} = concentration of Nitrosomonas

$$\mu_{ns} = \hat{\mu}_{ns} \frac{s_N}{K_{ns} + s_N} = \text{specific growth rate for Nitrosomonas} \quad (4.23)$$

s_N = concentration of ammonia nitrogen

For Nitrobacter the corresponding growth is

$$\frac{dc_{nb}}{dt} = \mu_{nb} \cdot c_{nb} \quad (4.24)$$

where

c_{nb} = concentration of Nitrobacter

$$\mu_{nb} = \hat{\mu}_{nb} \cdot \frac{s_{NO_2}}{K_{nb} + s_{NO_2}} = \text{specific growth rate for Nitrobacter} \quad (4.25)$$

s_{NO_2} = concentration of nitrite

Ammonia nitrogen s_N is consumed by the Nitrosomonas and is transferred to nitrite, s_{NO_2}

$$\frac{ds_N}{dt} = - \frac{\mu_{ns} \cdot c_{ns}}{Y_{ns}} \quad (4.26)$$

where Y_{ns} = yield constant

The nitrite concentration s_{NO_2} is increased due to the Nitrosomonas activity and is consumed due to the Nitrobacter bacteria activity,

$$\frac{ds_{NO_2}}{dt} = \frac{\mu_{ns} \cdot c_{ns}}{Y_{ns}} - \frac{\mu_{nb} \cdot c_{nb}}{Y_{nb}} \quad (4.27)$$

where Y_{nb} = yield constant for Nitrobacter.

The nitrite is transferred to nitrate NO_3^- , and the consumption term in (4.27) is corresponding to a production term of nitrate,

$$\frac{ds_{\text{NO}_3}}{dt} = \frac{\mu_{\text{nb}} \cdot c_{\text{nb}}}{Y_{\text{nb}}} \quad (4.28)$$

where s_{NO_3} = nitrate concentration.

4.3 Decay of microorganisms

The decay of microorganisms represent several different phenomena, i.e. endogeneous respiration and death. Empirically these phenomena together are assumed to follow a first order reaction kinetics,

$$\frac{dc_x}{dt} = -d_x \cdot c_x \quad (4.29)$$

$$\frac{dc_y}{dt} = -d_y \cdot c_y \quad (4.30)$$

The value of the specific decay term (d_x or d_y) is influenced by many of the factors influencing the specific growth rate.

The expression (4.29) has been empirically derived by many authors, e.g. McKinney (1962), Smith (1963) and Jaquart et al (1973), Andrews (1971). The relative importance of the decay term compared to the growth term depends on the substrate concentration. The maximum specific growth rate $\hat{\mu}_x$ is generally one or two orders of magnitude larger than the decay term. If the water should have a very low organic pollution content, then the decay term might be much more of importance.

The death of viable organisms transfers the viable bacteria into non-viable or inert organisms, i.e.

$$\frac{dc_z}{dt} = Y_z \cdot (d_x \cdot c_x + d_y \cdot c_y) \quad (4.31)$$

where c_z = concentration of non-viable organisms

Y_z = concentration of inert mass generated per unit concentration living organisms decayed.

Thus the eq. (4.31) represents the formation of non-viable bacteria from both sludge and dispersed bacteria.

In the endogeneous respiration the organisms are forced to metabolize their own protoplasm without replacement. Westberg (1967) has assumed that the decay term (d_x or d_y) depends on the available concentration of nutrients. According to Westberg the organism decay is

$$\frac{dc_x}{dt} = - \frac{\eta}{s} \cdot c_x \quad (4.32)$$

where η = decay coefficient and corresponding formation of inert bacteria

$$\frac{dc_z}{dt} = \frac{\eta}{s} \cdot c_x \quad (4.33)$$

The relationship between the endogeneous respiration and the available food is, however, not always so simple as the Westberg model describes. Sometimes it has been found, see Ericsson et al (1970) that the respiration is instead proportional to the substrate concentration.

The decay of Nitrosomonas and Nitrobacter follows a similar pattern as the Heterotrophs. Thus the decay terms are

$$\frac{dc_{ns}}{dt} = - d_{ns} \cdot c_{ns} \quad (4.34)$$

$$\frac{dc_{nb}}{dt} = - d_{nb} \cdot c_{nb} \quad (4.35)$$

for the Nitrosomonas and Nitrobacter respectively. Numerical values, suggested by Poduska-Andrews (1974) are listed in 4.5. Downing (1962) has assumed the decay is zero compared to other terms.

4.4 Dissolution of cell mass

In a model derived by Westberg (1967) the redissolution of inert bacteria into substrate is considered. The nutrients remaining in the dead cells diffuse out to furnish the remaining cells with food

(known as cryptic growth). The dissolution is caused by enzymes and the concentration of them is supposed to be proportional to the living organisms concentration. Thus the dissolution is proportional to both living and inert bacteria,

$$\frac{ds}{dt} = \psi \cdot c_x \cdot c_z \quad (4.36)$$

where $\psi = \text{constant}$.

Corresponding consumption of inert bacteria is then

$$\frac{dc_z}{dt} = -\psi c_x c_z \quad (4.37)$$

4.5 Numerical values of kinetic constants

Municipal sewage represents, perhaps, one of the most complex mixtures of carbon sources found in nature. Even under constant conditions as far as pH and temperature is concerned there is a wide spread in experimental data found for the kinetic constants for the waste. Also for heterogeneous mixtures of synthetic waste there is no such thing as "the" kinetic constant.

Table 4.1 gives a sample of numerical values found in the literature of different constants for the activated sludge equations. The waste is all the time domestic. It is clearly demonstrated that the constants must in most cases be determined for the actual plant under consideration.

Sometimes there is some confusion in the definition of the constants. In eq. (4.3) c_x means the concentrations of viable organisms. In some papers c_x represents the MLVSS or MLSS of the aerator. Therefore a relation between MLSS and concentration of viable organisms must be established. In a conventional activated sludge process about 34 % is active, in a step feed process about 28 % is active, see Busby-Andrews (1973). Smith et al (1970) has proposed that the maximum rate constant $\hat{\mu}_x$ (4.4) is not a constant but varies with something like loading,

$$\hat{\mu}_X = 5.5 - 2.9 \ln(1/L) \quad (\text{days}^{-1})$$

where L = process loading, kg BOD fed/day/kg sludge bacteria in system.

Most often the kinetic constants are determined experimentally. The stoichiometric constants can be theoretically determined conveniently by expressing them in electron equivalents. This has been done e.g. by Hultman (1975) and McCarty (1971, 1972).

Table 4.1 Kinetic constants for domestic waste.

	eq.	Andrews (1972)	Brett et al (1973)	Busby 1973	Curds (1971-73)	Fan et al (1973)	Gaudy (1971)	Jones (1973)	Ott et al (1971)	Poduska et al (1974)*	Smith 1970, 74	Westberg (1967)
$\hat{\mu}_x$ (h^{-1})	4.5	0.2	0.2	0.1- 0.2	0.3	0.1	0.31- 0.77 (mean =0.53)	0.3- 0.4	0.1	0.15- 0.2	0.2	0.2(= μ_x)
$\hat{\mu}_x$ (h^{-1})	4.4	-	0.06									
$\hat{\mu}_y$ (h^{-1})	4.13				0.5							
$\hat{\mu}_{pf}, \hat{\mu}_{pa}$ (h^{-1})	{4.16 4.18}				0.35							
$\hat{\mu}_{ns}$ (h^{-1})	4.23									0.04- 0.08	0.015	
$\hat{\mu}_{nb}$ (h^{-1})	4.25									0.04		
K_s (mg/l)	4.1			150	-			6-20				
K_x^1 (mg/l)	4.5	200			15	20	11-181 (mean 74)			100- 200	150	
K_x (mg/l)	4.4			80	-							
K_y (mg/l)	4.13				10							
K_{pf}, K_{pa} (mg/l)	{4.16 4.18}				12							
K_i (mg/l)	4.8	2000										
K_{ns} (mg/l)	4.23											0.063 {0.18-1.0
												1.0

eq. Andrews (1972) Brett et al (1973) Busby 1973 Curds (1971-73) Fan (1973) Gaudy (1971) Jones (1973) Ott et al (1971) Poduska et al (1974)* Smith 1970, 74 Westberg (1967)

K_{nb} (mg/l)	4.25									0.25-1.0	
Y_x	4.11		0.66	-							
Y_x^1	4.10	0.5	0.4	0.5	0.5			0.4		0.4-0.6	0.5
Y_y	4.14			0.5							0.4
Y_p	4.19				0.5						
Y_{ns}	4.26										
Y_{nb}	4.27										0.05
r_s	4.1					3.0					
f_s	4.1					0.45					
d_x (h^{-1})	4.29	0.005		0.03	0		0.002				0.0075
d_y (h^{-1})	4.30				0						
d_{ns} (h^{-1})	4.34									0.005	
d_{nb} (h^{-1})	4.35									0.005	
Y_z	4.31					0.25					
η ($gm^{-3}h^{-1}$)	4.32										
\mathcal{V} ($mg^{-1}h^{-1}$)	4.36					$5 \cdot 10^{-4}$					

$\left\{ \begin{array}{l} 0.05 \\ 0.03-0.1 \\ 0.02-0.08 \\ 0.02 \end{array} \right\}$

4
 $5 \cdot 10^{-4}$

* The kinetic constants are determined experimentally in the article.

5. DYNAMICS OF A COMPLETE MIX AERATOR

The mass balances for a complete mix reactor will be derived in this chapter. The purpose is to first show the equations in simplest possible form and later take other hydraulic patterns into consideration.

In many plants the aerators could in fact be described by a complete mix model. The activated sludge process is illustrated in fig. 5.1, where actual terminology is defined. It is assumed all the time that the water is in hydraulic equilibrium, so all water flows are determined statically. Moreover, as the concentrations of pollutants are so small the density of the water is not influenced noticeably by the concentration. The hydraulic flows are indicated in fig. 5.1. Moreover we define

V = total aerator volume
 r = fraction return activated sludge flow
 w = fraction waste activated sludge flow
 Q = influent flow coming from primary sedimentation

Indices are used in the chapter for following:

index r = refers to the return activated sludge
 w = refers to waste activated sludge
 e = refers to effluent from separator
 i = refers to influent to the aerator

The equations for mass balances of the different compounds in the aerator are derived in the rest of the chapter. The same type of procedure is followed everywhere in the equations. Thus the terms represents the following:

Accumulated mass = incoming via influent + incoming via return
 activated sludge - outgoing to separator +
 + growth - decay (or consumption)

(5.1)

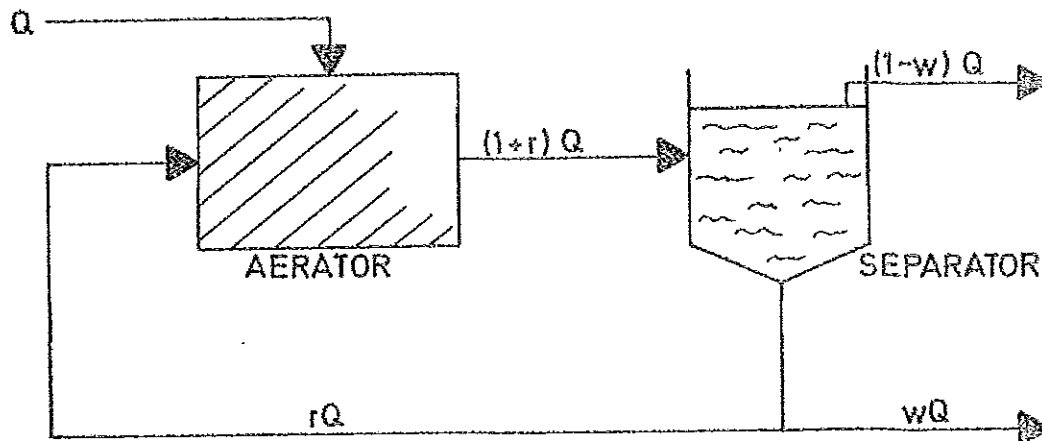

Fig. 5.1 Schematic flow diagram of a complete mix activated sludge system.

5.1 Sludge bacteria

The concentration of bacteria in the influent water can be neglected in comparison with the concentration in the aerator. The growth of the bacteria is defined by eq. (4.3) and their decay is likewise defined by (4.29). In the separator the flocculated bacteria are separated from the liquid and the bottom concentration in the separator is therefore larger than the aerator concentration. The mass balance equation now can be written in accordance with (5.1)

$$V \cdot \frac{dc_x}{dt} = r \cdot Q \cdot c_{x,r} - (1+r)Qc_x + V[\mu_x \cdot c_x - d_x \cdot c_x] \quad (5.2)$$

where c_x = sludge bacteria concentration.

If the time $\theta = V/Q$ is introduced (5.3)

or the dilution rate

$$D = \frac{Q}{V} \quad (5.4)$$

then (5.2) can be rearranged to

$$\frac{dc_x}{dt} = D[r \cdot c_{x,r} - (1+r)c_x] + \mu_x \cdot c_x - d_x \cdot c_x \quad (5.5)$$

The decay term $d_x c_x$ can also be replaced by

$$\frac{n}{s} c_x$$

according to eq. (4.32). If the biosorption is not taken into consideration, then m is replaced by s in μ_x , see eq. (4.5).

5.2 Dispersed bacteria

The dynamics of dispersed bacteria was considered by Curds (1973). It is assumed that their concentration is homogeneous throughout the system as they do not flocculate. The mass balance equation is formulated analogously to eq. (5.2), where the growth term is defined by eq. (4.12) and the decay from eq. (4.30). As the dispersed bacteria are consumed by the ciliates, eq. (4.19) represent the consumption. It is also assumed that the influent waste water contains these bacteria. The mass balance equation is

$$V \frac{dc_y}{dt} = Qc_{y,i} + rQc_y - (1+r)Qc_y + V[\mu_y \cdot c_y - \frac{\mu_p \cdot c_p}{Y_p} - d_y \cdot c_y] \quad (5.6)$$

or

$$\frac{dc_y}{dt} = D[c_{y,i} - c_y] + \mu_y \cdot c_y - \frac{\mu_p \cdot c_p}{Y_p} - d_y \cdot c_y \quad (5.7)$$

where

c_y = concentration of sewage bacteria

$c_{y,i}$ = concentration of dispersed bacteria in the influent water

5.3 Ciliated Protozoa

The mass balances for Ciliated Protozoa were formulated by Curds (1971). For the free-swimming Ciliates the concentration is assumed to be homogeneous, as no separation takes place, i.e.

$$c_{pf,r} = c_{pf}$$

The influent concentration is neglected,

$$c_{pf,i} = 0$$

The mass balance for free-swimming ciliates is then derived from (5.1), (4.15) and (4.16).

$$V \frac{dc_{pf}}{dt} = rQc_{pf} - (1+r)Qc_{pf} + V \cdot \mu_{pf} c_{pf} \quad (5.8)$$

or

$$\frac{dc_{pf}}{dt} = -Dc_{pf} + \mu_{pf} c_{pf} \quad (5.9)$$

For the attached Ciliates the influent concentration is also zero. As they will separate together with the sludge bacteria the return sludge concentration $c_{pa,r}$ is different from the aerator concentration c_{pa} . The mass balance is found from (5.1), (4.17) and (4.18),

$$V \cdot \frac{dc_{pa}}{dt} = r \cdot Qc_{pa,r} - (1+r)Qc_{pa} + V \cdot \mu_a \cdot c_{pa} \quad (5.10)$$

or

$$\frac{dc_{pa}}{dt} = D[rc_{pa,r} - (1+r)c_{pa}] + \mu_a \cdot c_{pa} \quad (5.11)$$

5.4 Inert microorganisms

The inert organisms are formed through the decay of viable organisms eq. (4.31). They are also consumed by the redissolution described in eq. (4.37). The mass balance equation is

$$\frac{dc_z}{dt} = D[c_{z,i} + rc_{z,r} - (1+r)c_z] + Y_z \cdot (d_x c_x + d_y c_y) - v c_x c_z \quad (5.12)$$

where

c_z = concentration of non-viable organisms

$c_{z,i}$ = concentration of non-viable organisms in the influent

According to Westberg (1967) the decay term d_x can be replaced by n/s or n/s_m (eq. (4.32)).

5.5 Organic substrate

The organic pollutant in the water is either in colloidal or in liquid phase. Here all substrate is described by just one state variable (s). The substrate then is not separated from the liquid in the sedimentation, so the concentration is considered homogeneous throughout the system. Substrate is added by the influent flow (s_i) and is consumed by transfer to stored mass (eq. (4.2)). It is also added new substrate by the redissolution of inert cell mass, eq. (4.36).

The mass balance then is

$$V \frac{ds}{dt} = Qs_i + rQs - (1+r)Qs + V \cdot v c_x c_z - V \cdot r_s \cdot c_T \left[\hat{f}_s \frac{s}{K_s + s} - f_s \right] \quad (5.13)$$

or

$$\frac{ds}{dt} = D(s_i - s) + r_s c_x c_z - r_s c_T \left[\hat{f}_s \cdot \frac{s}{K_s + s} - f_s \right] \quad (5.14)$$

5.6 Stored mass

By definition the concentration of stored mass is zero in the influent water. As described in 4.1 the stored mass is formed through a physical process and no respiration takes place. The stored mass is then consumed by the synthesis of bacteria. As the stored mass is included in the sludge bacteria it is natural to assume that it has the same sedimentation properties as the sludge bacteria. The mass balance equation is easily derived from eqs. (5.1), (4.1), (4.11), (4.14),

$$\begin{aligned} \frac{ds_m}{dt} = & D[r \cdot s_{m,r} - (1+r)s_m] + r_s \cdot c_T \left[\hat{f}_s \frac{s}{K_s + s} - f_s \right] - \\ & - \frac{\mu_x \cdot c_x}{Y_x} - \frac{\mu_y \cdot c_y}{Y_y} \end{aligned} \quad (5.15)$$

If it is assumed that the stored mass is neglected, then all suspended, colloidal and flocculated substrate is represented by one state variable, s_T

$$s_T = s + s_m \quad (5.16)$$

If eqs. (5.14) and (5.15) are added the result is

$$\frac{ds_T}{dt} = D[s_i + r \cdot s_{T,r} - (1+r)s_T] + r_s c_x c_z - \mu_y \cdot \frac{c_y}{Y_y} - \mu_x \frac{c_x}{Y_x} \quad (5.17)$$

The term s_i still represents the total amount of substrate concentration in the influent wastewater. The dissolution of inert bacteria is the same as before.

In the last term μ_x is a function of s_T instead of s_m . Those authors which have not taken stored mass into consideration most often assume that the substrate occurs only in suspended form, and the concentration is homogeneous in the whole system. The mass

balance for the total substrate then is

$$\frac{ds_T}{dt} = D(s_i - s_T) + r_c c_x c_z - \frac{\mu_Y \cdot c_Y}{Y_Y} - \frac{\mu_X \cdot c_X}{Y_X} \quad (5.18)$$

5.7 Summary of the dynamics with constant compaction ratio in the settler

In order to get a first approximation of the CSTR activated sludge process dynamics it is assumed that the compaction ratio in the liquid-solids separator is a constant γ . It is assumed that the sludge bacteria (c_x), stored mass (s_m), dead bacteria (c_z) and the attached Ciliates (c_{pa}) are concentrated in the same way, independent of flow rate, concentration or type of organisms, i.e.

$$\begin{aligned} c_{x,r} &= \gamma \cdot c_x \\ s_{m,r} &= \gamma \cdot s_m \\ c_{z,r} &= \gamma \cdot c_z \\ c_{pa,r} &= \gamma \cdot c_{pa} \end{aligned} \quad (5.19)$$

On the other hand, the substrate (s) and the dispersed bacteria (c_y) have a homogeneous concentration throughout the system.

The activated sludge dynamics for the complete mix system now can be summarized. Because of the slow dynamics of nitrification bacteria, nitrification is not considered here.

Substrate (s)

$$\frac{ds}{dt} = D(s_i - s) + r_c c_x c_z - r_s c_T \left[\hat{f}_s \frac{s}{K_s + s} - f_s \right] \quad (5.20) = (5.14)$$

Stored mass (s_m)

$$\frac{ds_m}{dt} = D[\gamma r - 1 - r] s_m + r_s c_T \left[\hat{f}_s \frac{s}{K_s + s} - f_s \right] - \frac{\mu_X \cdot c_X}{Y_X} - \frac{\mu_Y \cdot c_Y}{Y_Y} \quad (5.21) = (5.15)$$

Sludge bacteria (c_x)

$$\frac{dc_x}{dt} = D[r\gamma - 1 - r]c_x + \mu_x \cdot c_x - d_x \cdot c_x \quad (5.22) = (5.5)$$

Inert bacteria (c_z)

$$\frac{dc_z}{dt} = D[c_{z,i} + (r\gamma - 1 - r)c_z] + Y_z \cdot (d_x c_x + d_y \cdot c_y) - \nu c_x c_z \quad (5.23) = (5.12)$$

Dispersed bacteria (c_y)

$$\frac{dc_y}{dt} = D(c_{y,i} - c_y) + \mu_y \cdot c_y - \frac{\mu_p \cdot c_p}{Y_p} - d_y \cdot c_y \quad (5.24) = (5.7)$$

Free-swimming Ciliates (c_{pf})

$$\frac{dc_{pf}}{dt} = (-D + \mu_{pf})c_{pf} \quad (5.25) = (5.9)$$

Attached Ciliates (c_{pa})

$$\frac{dc_{pa}}{dt} = D[r\gamma - 1 - r]c_{pa} + \mu_{pa} \cdot c_{pa} \quad (5.26) = (5.11)$$

In case the stored mass is neglected, then (5.20) and (5.21) are replaced by (5.18).

It should be emphasized, that the dissolved oxygen level is assumed to be sufficiently high. If this concentration is limited then the dissolved oxygen concentration has to be included. This has been done in chapter 7. For the complete mix aerator with sufficient dissolved oxygen there is only one control variable, the return sludge flow rate r . The main disturbances are due to variations in the influent flow rate Q , affecting D or the influent concentration s_i .

6. DYNAMICS OF A STEP LOADED AERATOR

In the step loaded activated sludge process the organic load is distributed along the length of the aerator. This arrangement will even out the oxygen demand. Step loading results in relatively high mixed liquor solids concentration at the head end of the aerator tank and progressively lower concentrations along the stream. In the step loaded process multiple aeration tanks in series are often used. Such a system is illustrated by fig. 6.1. In other plants the aerator is a long tank, and the influent water is led into the tank at different points along the stream, fig. 6.2. To describe the system it is assumed, that the aerator can be represented by n subaerators, fig. 6.3. Each subreactor is a complete mix system with homogeneous concentrations. The influent wastewater is fed into each subreactor with the flow rate $\alpha_k Q$ into the subreactor k . The return activated sludge is always fed into the head end of the system.

Several special cases of the activated sludge process can be derived from the step loaded process. For $n=1$ there is a complete mix system, for $n = \infty$ the system is a plug flow process. A contact stabilization process is another special case of the step load system.

6.1 Hydraulic mass balances

The influent water enters the subreactors in the proportion $\alpha_1, \dots, \alpha_n$, where

$$\sum_{k=1}^n \alpha_k = 1 \quad (6.1)$$

is always satisfied.

In order to simplify the notation we define β_k , where

$$\begin{aligned} \beta_k &= \sum_{i=1}^k \alpha_i \\ \beta_0 &= 0 \\ \beta_n &= 1 \end{aligned} \quad (6.2)$$

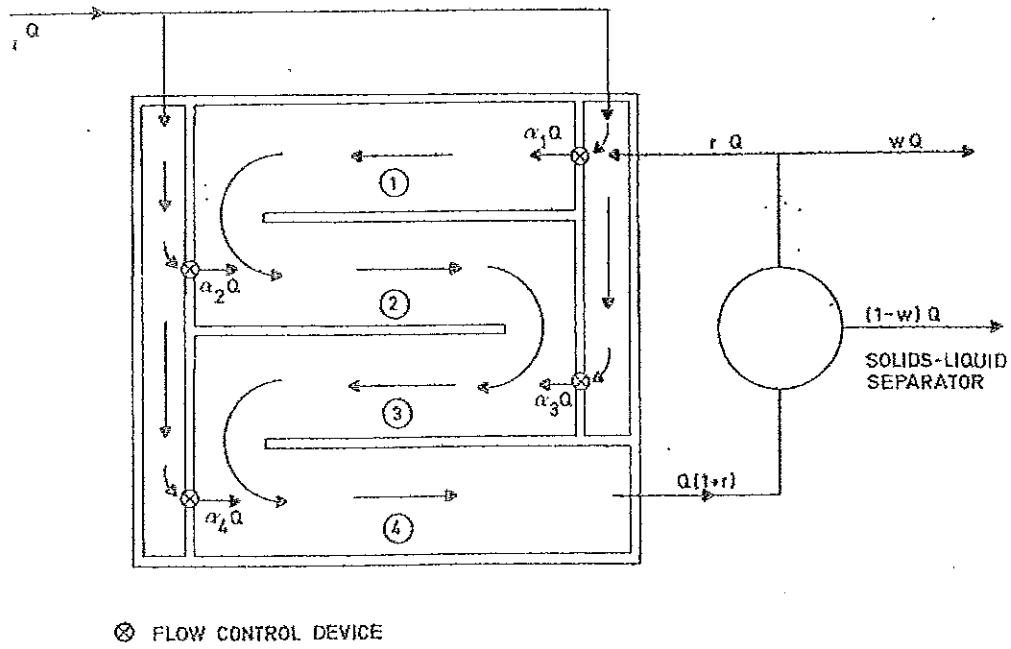

Fig. 6.1 Step loaded activated sludge system.

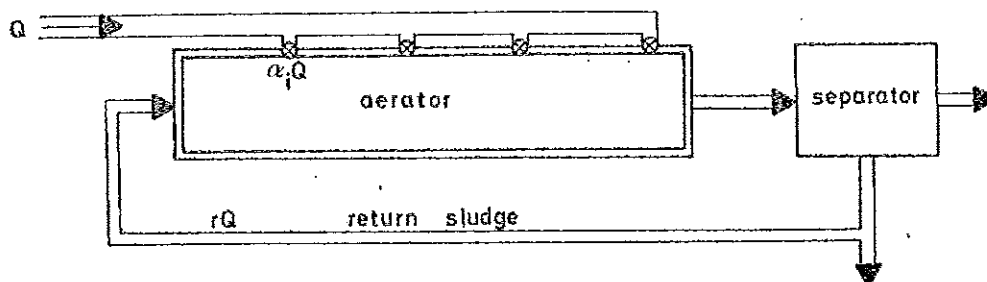

Fig. 6.2 Step loaded activated sludge system.

As the volume of subreactor k is V_k , the hold-up time τ_k is

$$\tau_k = \frac{V_k}{(\beta_k + r)Q} \quad (6.3)$$

It is assumed that the time delay in the return sludge flow can be neglected in comparison with the hold-up times of the subreactors. This is a reasonable assumption. The separator dynamics is a more crucial problem. As a first approximation the same static relations for the separator as in section 5.7 are assumed, i.e. constant compaction ratio γ .

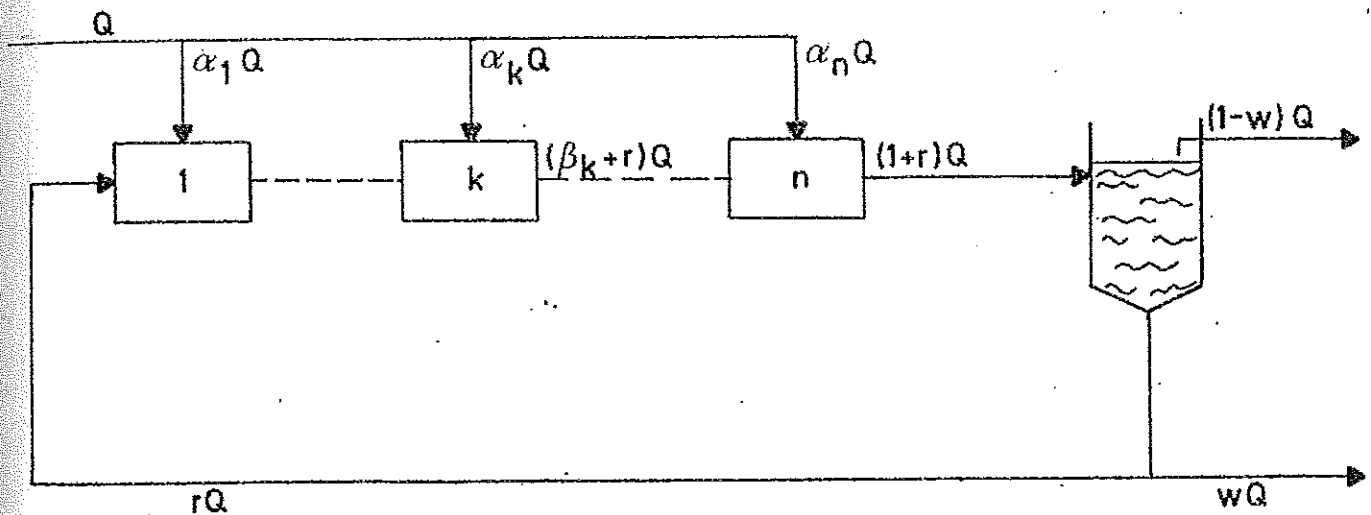

Fig. 6.3 Schematic flow diagram of a step loaded activated sludge system.

It is also assumed that the dissolved oxygen content is high enough, i.e. no dissolved oxygen dynamics is added. See further chapter 7.

6.2 Concentration equations

The mass balances can now be formulated analogously to those of a complete mix aerator, so the equations from chapter 5 can be generalized. The sludge bacteria equations is generalized from eq. (5.5).

With terminology from fig. 6.3 the mass balance equations reads

$$V_k \frac{dc_{x,k}}{dt} = \underbrace{(\beta_{k-1} + r) \cdot Q \cdot c_{x,k-1}}_{\text{from tank } k-1} - \underbrace{(\beta_k + r) \cdot Q \cdot c_{x,k}}_{\text{to tank } k+1} + V_k [\mu_{x,k} - d_x] c_{x,k} \quad k = 1, \dots, n \quad (6.4)$$

where index k refers to reactor no k .

By definition the index "o" refers to the recirculation,

$$c_{x,o} = c_{x,r} \quad (6.5)$$

If the time constant T_k is introduced

$$\theta_k = \frac{V_k}{Q} = \frac{1}{D_k} \quad (6.6)$$

then (6.4) is simplified to

$$\frac{dc_{x,k}}{dt} = D_k [(\beta_{k-1} + r) c_{x,k-1} - (\beta_k + r) c_{x,k}] + (\mu_{xk} - d_x) c_{x,k} \quad k = 1, \dots, n \quad (6.7)$$

The decay constant d_x can be replaced as in (5.5) by η_k/s_k .

The dispersed bacteria equations are (see (5.6))

$$\frac{dc_{y,k}}{dt} = D_k \{ \alpha_k c_{y,i} + (\beta_{k-1} + r) c_{y,k-1} - (\beta_k + r) c_{y,k} \} + \mu_{yk} \cdot c_{y,k} - \frac{\mu_{pk} \cdot c_{p,k}}{Y_{pk}} - d_y \cdot c_{y,k} \quad (6.8)$$

$$\text{where } c_{y,o} = c_{y,r} = c_{y,n} \quad (6.9)$$

The Ciliated Protozoa equations are, for free Ciliated Protozoa (eq. (5.8)),

$$\frac{dc_{pf,k}}{dt} = D_k \{ (\beta_{k-1} + r) c_{pf,k-1} - (\beta_k + r) c_{pf,k} \} + \mu_{pfk} \cdot c_{pf,k} \quad (6.10)$$

where

$$c_{pf,o} = c_{pf,r} = c_{pf,n} \quad (6.11)$$

and for attached Ciliated Protozoa (5.10)

$$\frac{dc_{pa,k}}{dt} = D_k \{ (\beta_{k-1} + r) c_{pa,k-1} - (\beta_k + r) c_{pa,k} \} + \mu_{pak} \cdot c_{pa,k} \quad (6.12)$$

where

$$c_{pa,o} = c_{pa,r} \quad (6.13)$$

For inert bacteria the relation is found from (5.12)

$$\begin{aligned} \frac{dc_{z,k}}{dt} = & D_k \{ \alpha_k c_{z,i} + (\beta_{k-1} + r) c_{z,k-1} - (\beta_k + r) c_{z,k} \} + \\ & + Y_z (d_x \cdot c_{x,k} + d_y \cdot c_{y,k}) - \gamma c_{x,k} c_{z,k} \quad | k=1, \dots, n \end{aligned} \quad (6.14)$$

The substrate mass balance is formulated from fig. 6.3 and eq. (5.13).

$$\begin{aligned} \frac{ds_k}{dt} = & D_k \{ \alpha_k s_i + (\beta_{k-1} + r) s_{k-1} - (\beta_k + r) s_k \} + \gamma c_{x,k} c_{z,k} - \\ & - \frac{\mu_{yk} \cdot c_{y,k}}{Y_y} - r_{sT,k} \left[f_{sk} \frac{s_k}{K_s + s_k} - f_{sk} \right] \end{aligned} \quad (6.15)$$

As the substrate does not settle the relation

$$s_r = s_n$$

holds, i.e.

$$s_o = s_r = s_n \quad (6.16)$$

The stored mass equations is analogous to (5.15),

$$\frac{ds_{m,k}}{dt} = D_k \{ (\beta_{k-1} + r) s_{m,k-1} - (\beta_k + r) s_{m,k} + r_s c_{T,k} \left[\hat{f}_{sk} \frac{s_k}{K_s + s_k} - f_{sk} \right] - \frac{\mu_{Xk} c_{X,k}}{Y_X} \} \quad k=1, \dots, n \quad (6.17)$$

6.3 Special plant configurations

The step loaded process can be specialized to different existing plant configurations. The complete mix reactor is already regarded in chapter 5. There are several other configurations described in the literature. The conventional process is the special case when $\alpha_1=1$, i.e. all the influent wastewater is entered at the head end of the reactor. Here we will generalize the step loaded process into the plug flow reactor, when the number of subreactors grows to infinity see 6.4. A common type of plant is the contact stabilization plant, which is noted in 6.6. Other configurations, less common, has been described by Stewart (1971) and also in standard text books, such as Metcalf & Eddy (1972).

6.4 Special case: Plug flow reactor

This reactor is the extreme case when the number of subreactors in the step loaded process goes to infinity. It is assumed, that the influent wastewater enters the reactor in one point, see fig. 6.4.

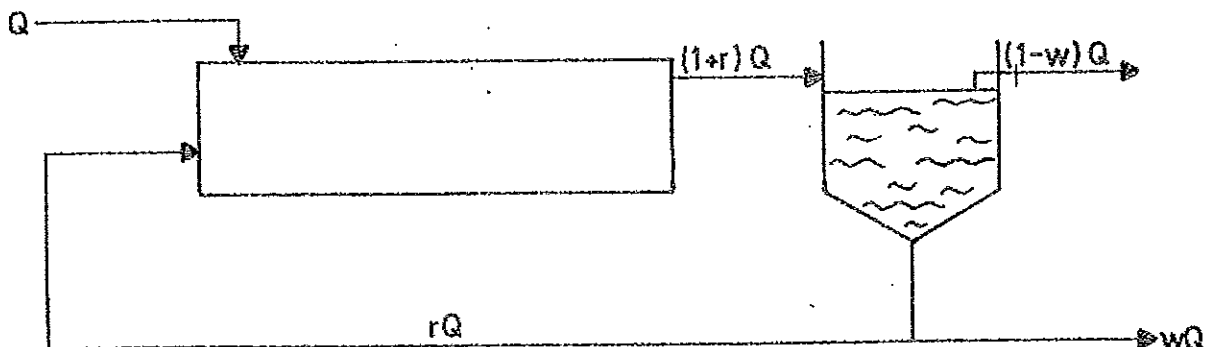

Fig. 6.4 Schematic flow diagram of the conventional activated sludge system.

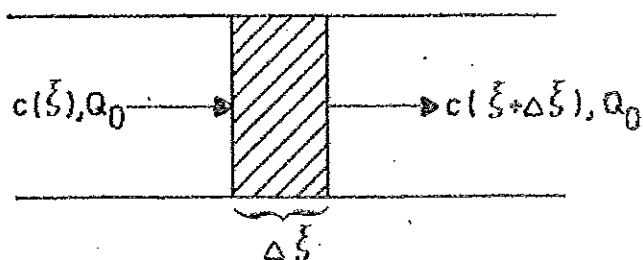

Fig. 6.5 Cross section of a plug flow reactor.

Consider a volume element with cross section A and length $\Delta \xi$ in the long reactor, fig. 6.5. As no diffusion or backmixing takes place the mass balance equation is easily derived. For any component the concentration c is function of the spatial variable ξ and time t .

$$c = c(\xi, t) \quad (6.18)$$

$$A \cdot \Delta \xi \frac{\partial c}{\partial t} = Q_0 c(\xi) - Q_0 c(\xi + \Delta \xi) + A \Delta \xi \cdot c_{\text{produced}} - A \Delta \xi \cdot c_{\text{consumed}} \quad (6.19)$$

By Taylor expansion we get for small $\Delta \xi$,

$$c(\xi + \Delta \xi) \approx c(\xi) + \frac{\partial c}{\partial \xi} \Delta \xi \quad (6.20)$$

Eq. (6.19) is then simplified to

$$\frac{\partial c}{\partial t} = - \frac{Q_0}{A} \cdot \frac{\partial c}{\partial \xi} + c_{\text{prod.}} - c_{\text{cons.}} \quad (6.21)$$

which is a generalization of (6.7) with $n=\infty$ and $\alpha_1=1$.

$\frac{Q_0}{A}$ is the stream velocity v .

$$\frac{\partial c}{\partial t} = - v \cdot \frac{\partial c}{\partial \xi} + c_{\text{prod.}} - c_{\text{cons.}} \quad (6.22)$$

Naturally eq. (6.22) can represent any component in the aerator, if the adequate production and consumption terms are inserted.

6.5 Special case 2: Plug flow reactor with dispersion

The plug flow is inadequate in many cases as the stream is not uniformly flowing in one direction. It is instead a certain amount of mixing and dispersion in the aerator of the waste. The mass balance equations can be formulated analogously to the plug flow case, provided a term is added that takes the effects of dispersion into account. The dispersion effect can be described by following term,

$$\frac{\partial M}{\partial t} = - E A \frac{\partial c}{\partial \xi} \quad (6.23)$$

where $\partial M / \partial t$ = mass flow

$\partial c / \partial \xi$ = concentration gradient

A = cross-sectional area

E = coefficient of eddy diffusion (or turbulent mixing)

i.e. the mass flow $\frac{\partial M}{\partial t}$ occurs in such a way as to reduce the concentration gradient.

The mass-balance equations can now be formulated from fig. 6.6.

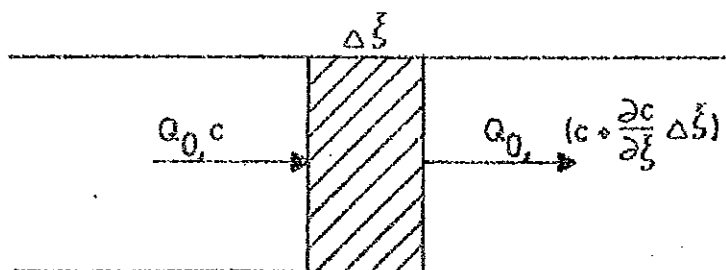

Fig. 6.6 Cross section of a plug flow aerator with diffusion.

The inflow per unit time is

$$Q_0 c(\xi) - EA \frac{\partial c}{\partial \xi} \quad (6.24)$$

and the outflow is

$$Q_0 \left(c + \frac{\partial c}{\partial \xi} \Delta \xi \right) - EA \frac{\partial}{\partial \xi} \left[c + \frac{\partial c}{\partial \xi} \Delta \xi \right] = Q_0 \left(c + \frac{\partial c}{\partial \xi} \Delta \xi \right) - EA \left[\frac{\partial c}{\partial \xi} + \frac{\partial^2 c}{\partial \xi^2} \Delta \xi \right] \quad (6.25)$$

The total mass balance for a component with concentration c is

$$A \cdot \Delta \xi \frac{\partial c}{\partial t} = Q_0 \cdot c - EA \frac{\partial c}{\partial \xi} - Q_0 c - Q_0 \frac{\partial c}{\partial \xi} \Delta \xi + EA \left[\frac{\partial c}{\partial \xi} + \frac{\partial^2 c}{\partial \xi^2} \Delta \xi \right] + \left[c_{\text{produced}} - c_{\text{consumed}} \right] A \cdot \Delta \xi \quad (6.26)$$

or

$$\frac{\partial c}{\partial t} = - \frac{Q_0}{A} \cdot \frac{\partial c}{\partial \xi} + E \cdot \frac{\partial^2 c}{\partial \xi^2} + c_{\text{produced}} - c_{\text{consumed}} \quad (6.27)$$

where $c = c(\xi, t)$

$$\frac{Q_0}{A} = v \text{ is the stream velocity}$$

In the sanitary engineering literature the amount of diffusion is often characterized by the Peclet number P_e ,

$$P_e = \frac{vL}{E} \quad (6.28)$$

which is a dimensionless quantity, where

v = stream velocity

L = tank length

E = diffusion constant

The diffusion equation (6.27) can be written in a normalized manner. Introduce the dimensionless length coordinate

$$\rho = \xi/L \quad (6.29)$$

Then (6.27) can be rewritten in the form

$$\frac{L}{v} \cdot \frac{\partial c}{\partial t} = \frac{1}{P_e} \frac{\partial^2 c}{\partial \rho^2} - \frac{\partial c}{\partial \rho} + \frac{L}{v} \cdot (c_{\text{prod.}} - c_{\text{cons.}}) \quad (6.30)$$

A plug flow reactor without dispersion is characterized by $E = 0$ or equivalently $P_e = \infty$. A complete mix reactor is the other extreme case with $P_e = 0$.

The spatial boundary conditions of the partial differential equation (6.30) are called the Danckwert's boundary conditions,

$$\text{At } \rho=0: \frac{1}{P_e} \cdot \frac{\partial c}{\partial \rho} = c - c^0 \quad (6.31)$$

$$\text{At } \rho=1: \frac{1}{P_e} \cdot \frac{\partial c}{\partial \rho} = 0 \quad (6.32)$$

where c^0 is the concentration at the mixing point just preceding the aerator vessel.

Empirically it has been found, that many aerators have quite a low Peclet number indicating that a considerable axial dispersion takes place. One expression is given by Murphy et al (1966), where

$$P_e = \frac{1}{2.9\tau} \quad (6.33)$$

where τ = hold-up time for the aerator.

The expression is derived for a laboratory set-up. Based on four full scale aerators Murphy (1970) presented a correlation of the Peclet number in an aerator to the detention time, geometric configuration and the air flow rate of the basin. The correlation was expressed as

$$P_e = 0.3125 \frac{(L/W)^2}{\tau \cdot Q_{\text{air}}^{0.346}}$$

where

- L = length of basin (m)
 W = width of basin (m)
 τ = aerator hold-up time (hrs)
 Q_{air} = air flow rate ($\text{Nm}^3/\text{min}/1000 \text{ m}^3$)

Special cases of the equation (6.30) have been used to predict the BOD and dissolved oxygen relationships in streams. Thomann (1967), Bella-Dobbins (1968) and Dresnack-Dobbins (1968) have derived similar diffusion equations as (6.30).

6.6 Special case 3: Contact stabilization

Formally a contact stabilization tank is achieved from fig. 6.3 if the influent of raw waste water is zero for the first subaerators, i.e. if the first $\alpha_1 = 0$. By this arrangement the volumetric loading (measured in $\text{kg BOD}/\text{day}/\text{m}^3$ of aeration tank) can be significantly increased compared to the conventional type of plant. In the absence of food supply the organisms get hungry and therefore the sludge is highly absorbtive when it is brought into contact with the raw sewage. When the substrate (food) is present in collodial or suspended form the contact stabilization tank is ideal. The suspended BOD will be absorbed rapidly in the relatively small aeration tank by the well-activated organisms.

The retention time in this so called contact tank may be very short, 1/4 hour to 1 hour. During such a short time very little oxidation of the organics can take place (see 4.1). Therefore the sludge entering the settling unit is composed of organisms and adsorbed BOD. In the stabilization tank (here represented by the first aerators) no raw sewage is added and the adsorbed organics are oxidized and thus stabilized. The stabilization time corresponding to 1/4 hour contact time may be 2.5 hours, according to Eckenfelder (1966, p. 164). At a contact time of maybe 4 hours no stabilization is required since all oxidation can take place in the contact tank. This is then a conventional activated sludge process. Stationary analysis of the kinetics of a contact stabilization process has recently been performed by Gujer et al (1975).

7. DISSOLVED OXYGEN DYNAMICS

In previous discussions it has been assumed that the biological activity is supplied with the proper amount of oxygen. In a practical situation this means, that the dissolved oxygen (DO) concentration in the aerator is more than 1 - 2 mg/l. The boundary between adequate amount and insufficient DO depends on the type of organisms and might be as low as 0.5 mg/l for filamentous bacteria with a large surface area/volume ratio.

The oxygen which is used by the organisms must be in dissolved form, and therefore many mechanisms determine the content of DO. The oxygen which is added through aeration have to be transported in many phases before it can be used by the organisms. It should be

- transferred from gas to dissolved phase
- diffuse to the floc surface
- penetrate the cell membrane
- be coupled to the electron transport chain

The oxygen transport is simplified significantly by turbulent mixing.

In this chapter we will consider four different mechanisms which determine the mass balance of DO in the aerator,

- mass transportation by the liquid flow
- aeration from the blowers
- oxygen consumption due to synthesis
- oxygen consumption due to endogeneous respiration

Cell synthesis generally requires much more oxygen than the respiration. In the literature the relation of 2 to 20 between these two phenomena is found.

7.1 Aeration of water

The transfer rate of oxygen from gas phase to dissolved phase is a function of the partial pressure in the gas phase and its concentration in the dissolved phase in the liquor. The saturation concentration in the liquid phase is determined from Henry's law.

$$c_{om} = K_h \cdot p_o \quad (7.1)$$

where

c_{om} = saturation concentration of dissolved oxygen (DO)

K_h = constant in Henry's law

p_o = partial pressure of gaseous oxygen

The value of c_{om} can be found in standard textbooks such as Eckenfelder (1966) and Metcalf & Eddy (1972). Typical values are $c_{om} = 10$ mg/l at 15 °C and 9 mg/l at 20 °C. The constant K_h is consequently a function of temperature and depending on other compounds dissolved in the liquor.

The oxygen transfer from gas to dissolved phase can be described

$$\frac{dc_o}{dt} = K_L \cdot a (c_{om} - c_o) \quad (7.2)$$

where $K_L a$ = oxygen transfer coefficient.

The coefficient is depending on a number of factors, e.g.

- o temperature; the coefficient increases with increasing temperature
- o turbulence; the more turbulent mixing the larger coefficient
- o depth of liquid. According to Eckenfelder (1966, p.66) the depth dependence can be written

$$\frac{K_L \cdot a(h_1)}{K_L \cdot a(h_2)} = \left(\frac{h_1}{h_2} \right)^n \quad (7.3)$$

where h_1 and h_2 are different depths, and the exponent $n = 0.7$

o the character of the raw wastewater

In our application, where the oxygen transfer is caused mainly by diffusers or air compressors the transfer coefficient can be written

$$K_L a = k_1 + k_2 u_{\text{air}} \quad (7.4)$$

where

k_1 = mass transfer without blowers

k_2 = a proportionality factor, depending on the special plant configuration

u_{air} = air flow

Numerical example

Typical values found in Käppala, Stockholm are

$$u_{\text{air}} = 50 \text{ Nm}^3/\text{min and aerator}$$

For six aerators this means

$$u_{\text{air}} = 18000 \text{ Nm}^3/\text{hour}$$

With respect to the known efficiency in the plant the oxygen transfer is 30 g oxygen/m³ · hour, or

$$(k_1 + k_2 u_{\text{air}}) (c_{\text{om}} - c_{\text{o}}) = 30$$

If it is assumed $k_1 = 0$, $c_{\text{o}} = 2,5 \text{ mg/l}$, $c_{\text{om}} = 10 \text{ mg/l}$

then

$$k_2 u_{\text{air}} = 4 \text{ h}^{-1}$$

$$k_2 = 0.22 \cdot 10^{-3} \text{ (Nm}^{-3}\text{)}$$

Wells-Stepner (1972) gives the values for the Palo Alto wastewater treatment plant,

$$k_1 = 0$$

$$k_2 u_{\text{air}} = 0.73 \text{ h}^{-1}$$

$$u_{\text{air}} = 1500 \text{ cfm} = 2500 \text{ Nm}^3/\text{hour}$$

which gives

$$k_2 = 0.29 \cdot 10^{-3} \text{ (Nm}^{-3}\text{)}$$

7.2 Oxygen consumption due to cell synthesis

The amount of oxygen needed for cell synthesis can be related directly to the amount of consumed substrate, i.e. removed BOD or COD. The expected amount of oxygen consumption is about 0.5 times the amount of BOD removed. If the substrate is given in COD the figure is somewhat lower. According to Eckenfelder (1966, p. 145) the oxygen requirement for synthesis is directly related to the growth term, represented by eqs. (4.3) or (4.12), (4.15), (4.17). Here we only consider sludge bacteria synthesis.

$$\frac{dc_{\text{O}}}{dt} = \frac{1-Y_x}{Y_x} \cdot \mu_x \cdot C_x \quad (7.5)$$

This relation is also used by Busby (1973). Similar expressions are also derived in earlier papers, e.g. Eckenfelder et al (1960) and McKinney (1963).

The growth rate μ_x is not only substrate dependent. It is also related to the DO content. This fact is easily demonstrated in a respirometer test. In the beginning of the respirometer test the test

water is aerated so that the oxygen level is close to saturation. In the short time scale the organism concentration is constant, and the oxygen consumption rate is constant, i.e. a zero order reaction. At a certain level, say c_{o1} , the oxygen consumption is a first order reaction, so the growth rate is approximately proportional to the oxygen concentration.

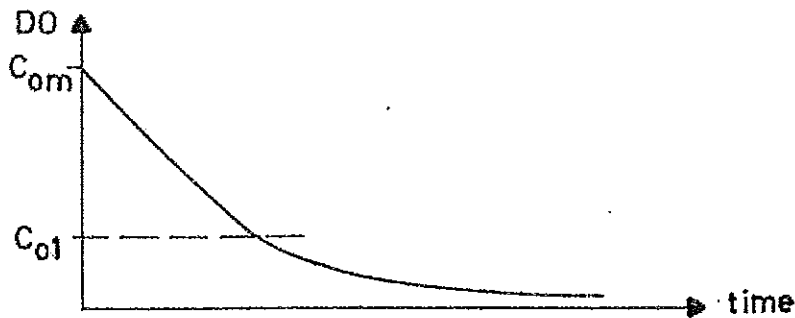

Fig. 7.1. Oxygen consumption in a respirometer test.

The respirometer test is illustrated by fig. 7.1. From the respirometer test the organism growth rate μ_x could be described approximately according to fig. 7.2.

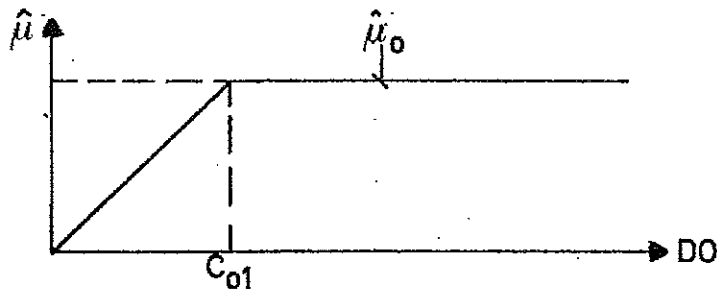

Fig. 7.2. Specific growth rate related to DO content for constant substrate concentration.

The oxygen consumption has been studied by e.g. Mueller et al (1968), who have given a somewhat more sophisticated expression for μ_x as function of DO concentration, see fig. 7.3.

The curve could be approximated with an exponential function

$$\hat{\mu} = \hat{\mu}_0 (1 - e^{-\kappa \cdot c_o}) \quad (7.6)$$

where

κ = constant

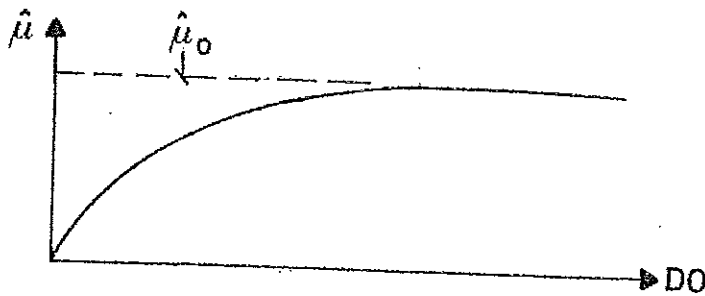

Fig. 7.3. Specific growth rate related to DO content for constant substrate concentration.

The oxygen concentration c_{o1} where the activity gets constrained, depends significantly on the floc size and is larger for larger flocs. In a normal plant c_{o1} is somewhere between 0.6 and 2.5 mg/l. The oxygen demand is much lower for dispersed bacteria, as remarked before. The c_{o1} value can be as low as 0.1 mg/l for dispersed bacteria. Therefore these compounds may dominate at low oxygen levels. As a secondary effect then the sludge has poorer settling properties and bulking sludge may result.

7.3 Oxygen consumption due to respiration

The endogeneous respiration is a function of the amount of living mass, see eq. (4.29). The oxygen consumption due to endogeneous respiration is directly proportional to the concentration of living organisms, i.e.

$$\frac{dc_o}{dt} = -d_o \cdot c_x \quad (7.7)$$

The coefficient d_o is independent of the substrate concentration and

of the DO concentration. The reported rate of endogeneous respiration for sludges varies quite a lot. Eckenfelder (1966, p. 146) gives the values

$$d_o = 8 - 27 \text{ mg oxygen}/(\text{hour})(\text{g VSS})$$

where VSS = volatile suspended solids.

If it is assumed that 50 % of the VSS consists of viable organisms, then

$$d_o = 0.016 - 0.054 \text{ hrs}^{-1}$$

Busby (1973) has used the value

$$d_o = 0.023 \text{ hrs}^{-1}$$

It should be remarked, that if the d_o value is related to VSS instead of viable organisms, then a low value of d_o usually reflects a high nonviable content of the sludge.

7.4 Oxygen mass balances

The oxygen mass balance equations for a step loaded activated sludge process are now derived. They are found in complete analogy with the mass balances in chapter 6. The definitions of the streams are found in fig. 6.3. The inflow of DO comes from raw sewage and from previous subreactor $k-1$. The outflow goes to subreactor $k+1$. DO is added according to eq. (7.2) and is consumed by synthesis (eq. (7.5)) and by endogeneous respiration (eq. (7.7)). The conditions in the settler and in the return sludge are septic, so the DO concentration there is assumed to be zero,

$$c_{oo} = c_{or} = 0 \tag{7.8}$$

The mass balance for subreactor k then is

$$\frac{dc_{ok}}{dt} = D_k \{ \alpha_k c_{oi} + (\beta_{k-1} + r) c_{o,k-1} - (\beta_k + r) c_{ok} \} + (k_1 + k_2 u_{air}) (c_{om} - c_{ok}) - \frac{(1 - Y_x)}{Y_x} \cdot \mu_x \cdot c_x - d_o \cdot c_x \quad (7.9)$$

where

c_{oi} = DO content in raw sewage

c_{ok} = DO content in subreactor k

$\mu_x = \mu_x(s, c_o)$ or $\mu_x = \mu_x(s_m, c_o)$

c_x = sludge bacteria

Nitrification is not considered here. Otherwise if nitrification occurs, the conversion of ammonia nitrogen to nitrate can represent a considerable oxygen demand on the system (see 3.4).

If dispersed bacteria and Ciliated Protozoa should be considered, then a corresponding term due to cell synthesis of these species should be added to eq. (7.9).

8. SETTLER DYNAMICS

The behaviour of the settler is crucial for the whole activated sludge operation. The settler has two completely different tasks in the process chain. An ideal settler should give

- a high compaction ratio
- low effluent suspended solids concentration
- high buffer volume of sludge

The ultimate goal of the treatment should be to produce an effluent with minimal BOD and suspended solids content. Therefore the whole biological operation should be maintained in such a way as to produce a sludge of desirable settleability properties. Actually very little is known how to produce such a sludge under dynamical conditions. A high compaction ratio is desirable from the sludge treatment point of view. Moreover, it makes it possible to keep a large mass of sludge as a buffer in the settler, in order to meet influent disturbances. On the other hand if the sludge blanket level is too high, then the effluent will be deteriorated.

In this paper only the thickening properties of the settler are considered, as those are the factors that directly influence the biological aerator dynamics. Of course also the effluent quality must be considered for the total plant behaviour.

The hydraulic mass balances for a settler with constant compaction ratio are derived in 8.1. Some empirical and semi-empirical results on static conditions of a settler are described in 8.2. Dynamical properties are discussed in 8.3.

As so little is known about settler dynamics in general the compaction ratio is often considered as an input variable in later simulations. In a real plant control situation probably the most realistic approach is to update the compaction ratio by on-line measurements.

8.1 Mass balances

Mass balances under static conditions are now considered. It is assumed that the compaction ratio γ and the settler efficiency ϵ are constant. Those parameters are the only ones used here to characterize the settler behaviour. The compaction ratio is defined as the concentration of suspended solids in the underflow stream from the settler divided by the mixed liquor suspended solids concentration. The efficiency is the concentration of suspended solids in the effluent water divided by mixed liquor suspended solids concentration.

It can be assumed that hydraulic equilibrium is achieved all the time. Fig. 8.1 defines the flows in the different streams around the settler. The indices refer to

- r = recirculation
- w = waste activated sludge
- e = effluent stream

Now consider the mass balance equations for the sludge, here represented by the sludge bacteria. The solids concentrations are

$$\begin{aligned} c_{x,r} &= \gamma \cdot c_x \\ c_{x,e} &= \epsilon \cdot c_x \\ c_{x,w} &= c_{x,r} \end{aligned} \quad (8.1)$$

The mass balance equation for the sludge is given for the stationary case to

$$(1+r)Q c_x = (1-w) Q c_{x,e} + r Q c_{x,r} + w Q c_{x,w} \quad (8.2)$$

With eqs (8.1) inserted the equations is

$$1 + r = (1-w)\epsilon + (r+w) \gamma \quad (8.3)$$

or

$$w = \frac{1+r-r\gamma-\epsilon}{\gamma-\epsilon} \quad (8.4)$$

The efficiency ϵ is of the order 0.01-0.1 and the compaction ratio γ of the order 3-5. Therefore (8.4) is often simplified to

$$w = \frac{1+r-r\gamma}{\gamma} \quad (8.5)$$

Observe, however, that if the recirculation r is large, then this approximation is doubtful.

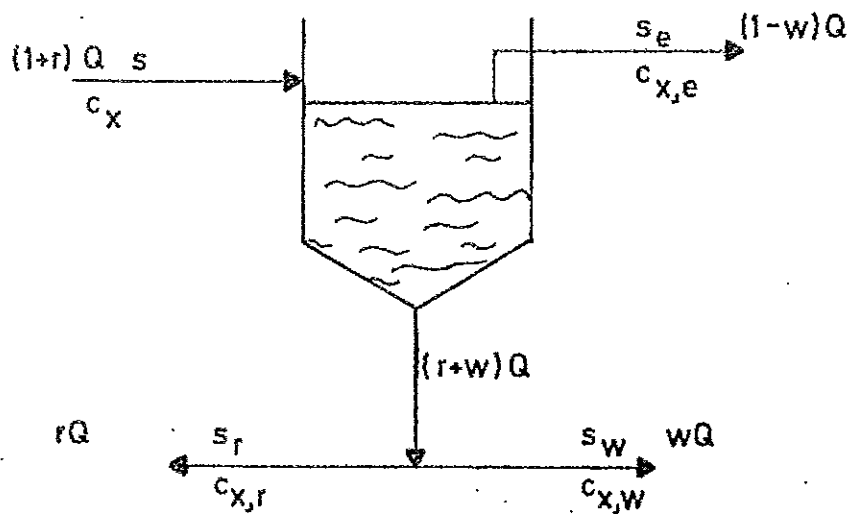

Fig. 8.1. Definitions of flows and concentrations in the separator.

8.2 Empirical results

Westberg (1972) has described an empirical expression for the compaction ratio γ . By experience it is found, that γ follows a static relation

$$\gamma = 4 + \frac{V_s}{2(r+w)Q} - \frac{4}{\tau} \quad (8.6)$$

where V_s = volume of the settler

τ = hold up time in the aerator (hours)

The explanation for the formula goes as follows. The compaction ratio 4 is considered an average value for "normal" operations in "normal" plants. The second term depends on the nominal hold-up time in the settler, $V_s/(r+w)Q$ (see fig. 8.1). The last term cor-

responds to the load in the reactor. If the load is high then a higher sludge mass must be held in the system. The compaction decreases with increasing sludge concentration and mass.

Example: If the settler hold-up time is 1 hour and $\tau = 4$ hours, then $\gamma = 3.5$.

Some values of the compaction ratio found in the literature are listed in table 8.1.

Table 8.1.

Values of a constant compaction ratio γ , found in literature

Andrews (1972)	4.85, 4
Curds (1971,73)	1.9
Ott (1971)	4
Smith (1970)	3.48

Other expressions for the compaction ratio has been derived e.g. by Naito et al (1969). The model is derived from empirical data and assumes plug flow in the separator. The semiempirical model is derived for a rectangular separator with horizontal flow. The compaction ratio is only a function of sludge concentration leaving the aerator and the underflow concentration. In principle the ratio decreases for increasing MLSS concentration.

McKinney (1962) has shown that the sludge settleability is dependent of the growth rate of the process. If the system is operated at a high growth rate, the relative energy level is sufficiently high to keep all the microorganisms completely dispersed. At lower growth rates, the energy of the system is lower, and cells lack energy to overcome the forces of attraction once they have collided. Thereby they promote floc formation.

Those statements have been verified through experiments by Bargman et al (1973) made at the Hyperion plant in Los Angeles. The authors have shown that suspended solids removal in the settler depends on net growth rate in the aerator, on substrate loading and on settler

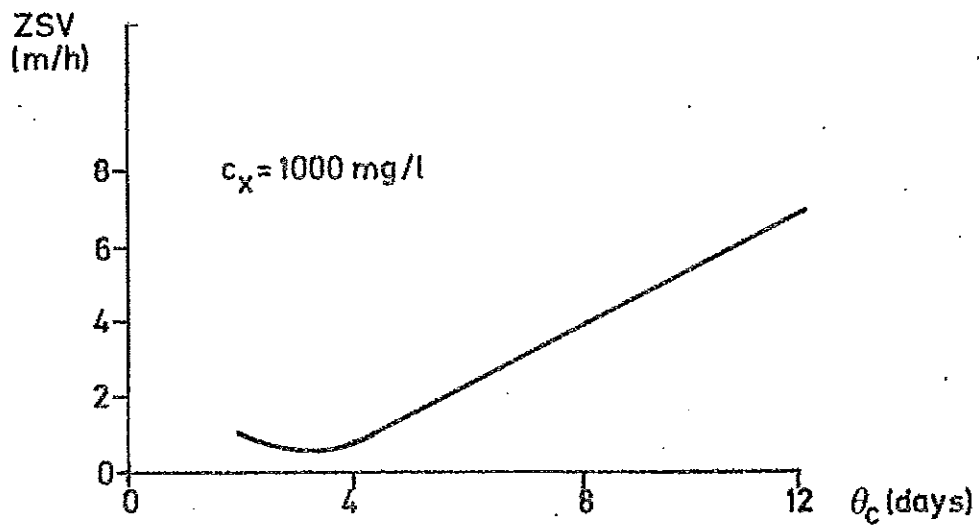
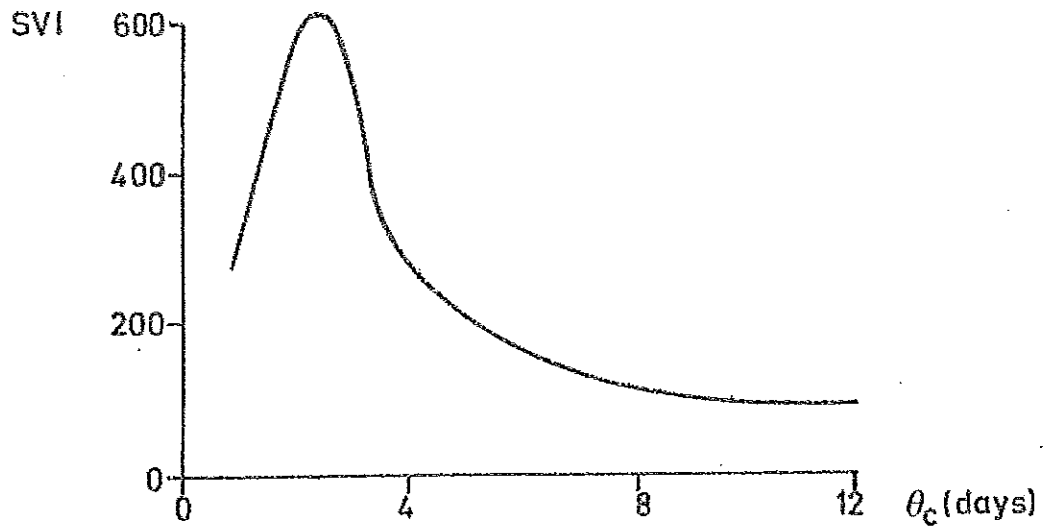

Fig. 8.2. Sludge volume index and zone settling velocity as function of the sludge age in a settler, according to Bisogni et al (1971).

hydraulic loading. A definite correlation was found to exist between net growth rate (or substrate loading) and suspended solids in secondary effluent. A good correlation was also found between hydraulic loading and secondary effluent quality. The suspended solids removal increases due to decreasing substrate loading, decreasing net growth rate or decreasing hydraulic load.

In a study by Bisogni et al (1971) a relationship between mean cell residence time and sludge volume index SVI and zone settling velocity ZSV has been found. The results are given in fig. 8.2. Based on these results it may be concluded that sludge settling properties are best at higher values of θ_s where the SVI is min and ZSV is max.

8.3 Dynamical models

During the last five or six years the dynamical models for the aeration chamber in an activated sludge process have evolved to relatively structured status. Nonetheless they lack verification at both the pilot and full scale levels. Dynamic models for the secondary clarifier/settler have not yet attained this level of development. Further none of the existing models have been used as part of the control strategies that currently are employed in full-scale systems.

Any dynamical model of the secondary clarifier must be able to predict the concentration of suspended solids in the overflow as well as the concentration of the following

- concentration of the biological solids in the underflow
- solids blanket height
- solids concentration profile in the settler
- concentration of solids in the overflow (effluent)

in response to dynamic changes in the influent and underflow rates of flow and the influent solids concentration.

Many modern works in thickening theory and dynamical models are based on the work by Kynch (1952). Kynch proposed a theory of sedi-

mentation which lead to the conclusion that the various thickened sludge concentration layers rise at constant velocities, i.e. the settling velocity of a layer is a function of the particle concentration within that layer.

Dick-Ewing (1967) have made a comprehensive review and evaluation of current thickening theories. Even if thickening theory contains a number of contradictions and disagreements it appears that the Kynch theory can be used as a rational basis for dynamical model development. This has been done e.g. by Alkema (1971), Dick-Javaheri (1972), Bryant (1972) and Tracy-Keinath (1973). The settler model presented here was derived first by Bryant (1972) and Busby (1973) who have based their work on the previous Kynch theories. Consider the schematic figure of the settler in fig. 8.3. The feed to the settler consists of the mixed liquor from the aerator. It is assumed that the clarifier has a plug flow, so that there is no intermixing of the basin contents as the mixed liquor enters the basin. It is further assumed that the basin can be considered to have two distinct layers, the clarification zone and the thickening zone. Here we consider only the thickening zone.

When a slurry enters a solids-liquid separator where there is removal of the thickened solids from the bottom (fig. 8.3) two forces act on the solids transported to the bottom of the vessel. One of these is the bulk movement of the entire slurry downward which transfers the solids downward at a velocity proportional to the withdrawal rate. The solids settling mechanism is the other mode which carries solids into the sludge thickening zone. In fig. 8.4. the settling flux is shown as a function of the solids concentration. According to the Kynch theory the settling curve is the bellshaped curve. The solids flux due to the withdrawal rate is a straight line with the slope dependent on the bulk velocity. The total flux curve is achieved as the sum of the two curves. The minimum of the total solids flux represents the maximum solids handling capacity of the final clarifier at a given underflow velocity. If the underflow velocity is decreased, the minimum in the total solids flux curve

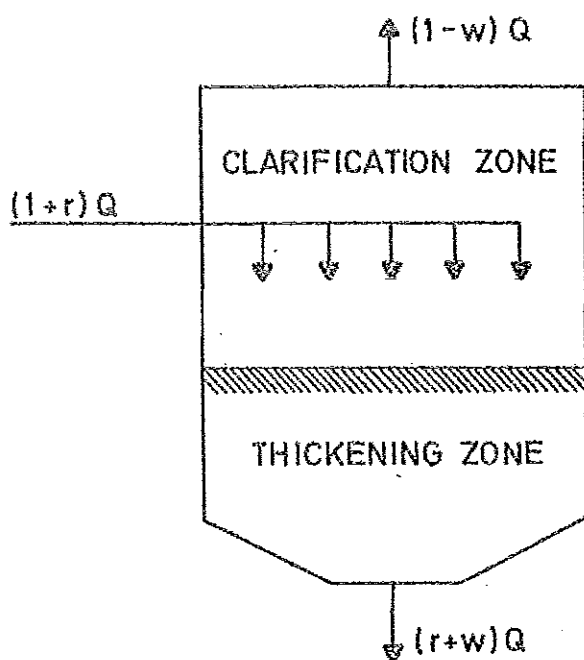

Fig. 8.3. Schematic of the settler.

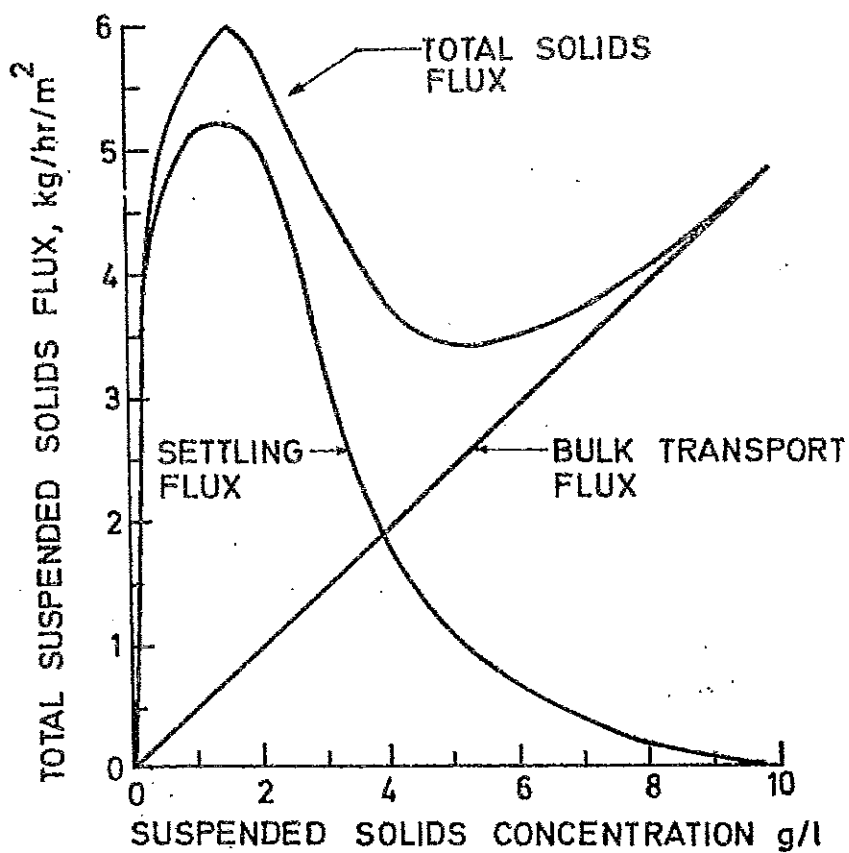

Fig. 8.4. Solids flux curves for the settler.

will shift to the right. If the underflow velocity is increased, the minimum in the total solids flux moves to the left. Under steady state operation conditions at a constant underflow velocity a solids concentration layer—corresponding to the minimum in the total solids flux curve will form in the sludge thickening zone. All solids would be required to pass through this concentration layer before they could leave the basin in the clarifier underflow.

A mass balance for a thickening layer can now be derived. The two mentioned mechanisms are considered. According to fig. 8.5 a solids mass balance can be written

$$\frac{dc_s}{dt} \cdot A_s \cdot \Delta\zeta = A_s [\phi_s(\zeta) - \phi_s(\zeta + \Delta\zeta) + v_s \cdot c(\zeta) - v_s c(\zeta + \Delta\zeta)] \quad (8.7)$$

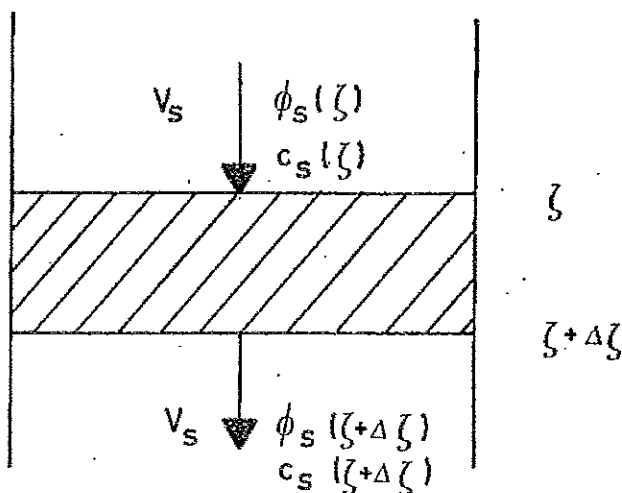

Fig. 8.5. Schematic cross section of a separator sludge thickening zone.

where

c_s = total suspended solids concentration in the thickening zone (kg/m^3)

A_s = cross section area

z = vertical distance in the settler

ϕ_s = gravitational solids flux (kg/hr/m²)

v_s = bulk (downward) flow velocity

The terms are expanded in a Taylor series and the layer thickness is assumed infinitesimally small. Then (8.7) is written as

$$\frac{\partial c_s}{\partial t} = - \frac{\partial \phi_s}{\partial z} - v_s \cdot \frac{\partial c_s}{\partial z} \quad (8.8)$$

or

$$\frac{\partial c_s}{\partial t} = - \left(v_s + \frac{\partial \phi_s}{\partial c_s} \right) \cdot \frac{\partial c_s}{\partial z} \quad (8.9)$$

The boundary conditions at the bottom is

$$\frac{\partial \phi_s}{\partial z} = 0 \quad (8.10)$$

as the solids cannot settle through the impermeable basin bottom. At the feed level it is assumed that the influent solids have the settling flux associated with the influent concentration. The partial differential equation (8.9) was solved by Bryant (1972) and later by Busby (1973) by spatial lumping into ten ordinary differential equations.

It is clear that a solution of the settler dynamical equations can be achieved only when an appropriate expression for the relation $\frac{\partial \phi_s}{\partial c_s}$ is available. Bryant (1972), Alkema (1971) and Tracy (1973) obtained expressions for this term by experimentally determining a relation for the initial interfacial settling velocity as a function of the concentration of suspended solids. A detailed expression for $\frac{\partial \phi_s}{\partial c_s}$ was derived by Dick (1970). In an activated sludge process, however the settling characteristics and therefore the term $\frac{\partial \phi_s}{\partial c_s}$ change continually. Consequently, if a dynamic model of the activated sludge

process is to be fully useful from a control point of view, it is imperative that the expression for $\partial\phi_s/\partial z$ be updated continuously. This could be done either by (i) offline measurement of the settling properties of the biological slurry or (ii) prediction of the settling properties by reference to various biological process parameters. The latter approach is of course preferable as a control law can include the settling properties. On the other hand, the former approach also provides a means for feedback control.

Considerable research has been directed towards determining the biological factors that affect sludge settling relationships, both clarification and thickening. These have focused on delineating the effects of organic loading and oxygen tension on sludge settleability and on effluent clarity. A recent survey has been given by Keinath (1974). It must be emphasized that all studies conducted regarding the effects on biological factors on sludge settleability and effluent clarity were made under pseudo steady-state conditions. Consequently, these studies can only be employed to indicate trends. Essentially no studies have been conducted to get dynamic relationships between sludge settleability and various process parameters.

APPENDIX

LIST OF SYMBOLS

VARIABLE NAMESKINETIC CONSTANTS

c = concentration of microorganisms or oxygen

s = concentration of substrate

The equation numbers refer to the first time a specific symbol is used. Subscripts

x = sludge bacteria

y = dispersed bacteria

z = inert bacteria

pa = attached ciliated protozoa

pf = free ciliated protozoa

ns = Nitrosomonas

nb = Nitrobacter

m = stored mass

N = ammonia nitrogen

NO₂ = nitrite

NO₃ = nitrate

o = oxygen

Microorganism concentrations

c_x (4.3) = sludge bacteria

c_y (4.12) = dispersed bacteria

c_{pf} (4.15) = free ciliated Protozoa

c_{pa} (4.17) = attached Ciliated Protozoa

c_{ns} (4.22) = Nitrosomonas

c_{nb} (4.24) = Nitrobacter

c_z (4.31) = inert bacteria

$c_T = c_x + c_z + s_m$ (4.1)

Substrate concentrations

- s (4.2) = soluble substrate concentration
 s_m (4.1) = stored mass
 s_T (5.16) = total substrate concentration ($=s+s_m$)
 s_N (4.23) = ammonia nitrogen
 s_{NO_2} (4.25) = nitrite
 s_{NO_3} (4.28) = nitrate

Kinetic constants

Specific growth rate constants

- $\mu_x \mu_y \mu_{pf} \mu_{pa} \mu_{ns} \mu_{nb}$ (see further table 4.1)

Maximum specific growth rate constants

- $\hat{\mu}_x \hat{\mu}_y \hat{\mu}_{pf} \hat{\mu}_{pa} \hat{\mu}_{ns} \hat{\mu}_{nb}$ (see table 4.1)

Growth limiting constants

- $K_s K_x K_x^1 K_i K_y K_{pa} K_{pf} K_{ns} K_{nb}$ (see table 4.1)

Yield constants

- $Y_x Y_x Y_y Y_p Y_{ns} Y_{nb} Y_z$ (see table 4.1)

Decay constants

- $d_x d_y d_{ns} d_{nb}$ (see table 4.1)

- r_s (4.1) = transfer rate constant
 f_s (4.1) = fraction of MLVSS that is stored mass
 \hat{f}_s (4.1) = maximum of f_s
 η (4.31) = decay constant
 ϑ (4.36) = dissolution constant

Aerator constants

Subscripts

- r = refers to return flow
- w = refers to waste activated sludge
- e = refers to effluent from separator
- i = refers to incoming influent to the aerator
- s = refers to separator

Hydraulic flows (see fig. 5.1 and 6.3)

- V = aerator volume
- Q = influent flow coming from primary sedimentation
- rQ = return activated sludge flow
- wQ = waste activated sludge flow
- α_k = fraction of influent water entering subreactor k.
- $\beta_k = \sum_{i=1}^k \alpha_i$

Constants

- $\theta(5.3) = V/Q =$ hold-up time
- $D(5.4) = 1/T =$ dilution rate
- $\gamma(5.19) =$ compaction ratio in the settler
- $\tau_k(6.3) = \frac{V_k}{Q(\beta_k + r)} =$ hold-up time of subreactor k
- A(6.18) = cross section of plug flow reactor
- v(6.22) = stream velocity in plug flow reactor
- E(6.23) = Diffusion constant
- $P_e(6.28) =$ Peclet number

Oxygen constants

- $c_o(7.2) =$ Dissolved oxygen concentration
- $c_{om}(7.1) =$ saturation value of DO concentration
- $K_L \cdot a(7.2) =$ oxygen transfer coefficient
- $u_{air}(7.4) =$ air flow
- (7.6) = constant
- $d_o(7.7) =$ coefficient for oxygen uptake due to respiration

Settler constants

$\gamma(8.1)$ = compaction ratio

$\epsilon(8.1)$ = settler efficiency

$c_s(8.7)$ = total SS in settler

$A_s(8.7)$ = cross section in settler

$\phi_s(8.7)$ = solids flux

$v_s(8.7)$ = bulk flow velocity

REFERENCES

- Alkema, K.L. (1971). The effect of settler dynamics on the activated sludge process. MS Thesis, Univ. of Colorado, Boulder, Colorado.
- Andersson, R. (1963). Phd thesis, Dep. of Bacteriology, Univ. of Wisconsin.
- Andrews, J.F. (1971). Kinetic Models of Biological Waste Treatment Processes. Biotechnology and Bioengineering Symposium No. 2. John Wiley & Sons, New York.
- Andrews, J.F. (1972). Dynamic Models and control strategies for wastewater treatment processes. Eight Annual Workshop, Association of environmental engineering professors, Nassau, Bahamas, Dec. 18-22.
- Andrews, J.F. (1974). Kinetics and mathematical modeling. In Ecological aspects of wastewater treatment. (Hawkes H.A. and C.R. Curdes eds.), Academic Press, London.
- Andrews, J.F. (1974). Dynamic models and control strategies for wastewater treatment processes. Water Research, 8, 261.
- Bargman, R.D. and J. Borgerding (1973). Characterization of the activated sludge process. US Environmental Protection Agency, Environmental Protection Technology Series no EPA-R2-73-224, April 1973.
- Bella, D.A. and W.E. Dobbins (1968). Difference modeling of stream pollution. J. of the Sanitary Engineering Division, ASCE, 94, SA5, 995-1016.
- Bisogni, J.J. and A.W. Lawrence (1971). Relationships between biological solids retention time and settling characteristics of activated sludge. Water Research, 5, 753.

- Blackwell, L.G. (1971). A theoretical and experimental evaluation of the transient response of the activated sludge process. Ph.D. dissertation. Clemson Univ., South Carolina.
- Brett, R.W.J., R.I. Kermode and B.G. Burrus (1973). Feed forward control of an activated sludge process. *Water Research*, 7, 525-535.
- Bryant, J.O. (1972). Continuous Time Simulation of the Conventional Activated Sludge Wastewater Renovation System. Ph.D. Dissertation, Clemson University, Clemson, South Carolina.
- Busby, J.B. (1973). Dynamic modeling and control strategies for the activated sludge process. Ph.D. dissertation, Clemson University, Clemson, South Carolina.
- Busby, J.B. and J.F. Andrews (1973). Dynamic modeling and control strategies for the activated sludge process. Presented at the 46th Annual conf. of the Water Pollution Control Federation, Cleveland, Sept. 30 - Oct. 5.
- Canale R.P. et al (1973). Experimental and Mathematical Modeling Studies of Protozoan Predation on Bacteria. *Biotechnology and Bio-engineering*, XV, 707-728.
- Clifford, D. (1967). Total Oxygen Demand - A new Instrumental Method. *Am. Chem. Soc. Midland, Mich.*
- Curds, C.R. (1971 a). A computer simulation study of predator-prey relationships in a single-stage continuous-culture system. *Water Research*, 5, 793-812.
- Curds, C.R. (1971 b). Computer simulations of microbial population dynamics in the activated sludge process, *Water Research*, 5, 1049-1066.

Curds, C.R. (1973). A theoretical study of factors influencing the microbial population dynamics of the activated sludge process
Part I, Water Research, 7, 1269-1284.
Part II, Water Research, 7, 1439-1452.

Dick, R.I. and B.B. Ewing (1967). Evaluation of activated sludge thickening theories. Journal of the Sanitary Engineering Division, Proc. ASCE, 93, SA4, 9-29.

Dick, R.I. (1970). Role of activated sludge final settling tanks. Journal of Sanitary Engineering Division, Proc. ASCE, 96, 423-436.

Dick, R.I. and A.R. Javaheri (1972). "Continuous Thickening of Non-Ideal Suspensions". WRC Research Report No. 45, University of Illinois, Urbana (March).

Downing, A.L. and A.B. Wheatland (1962). Fundamental considerations in Biological Treatment of Effluents. Trans. Inst. Chem. Engr., 40, 91.

Dresnack, R. and W.E. Dobbins (1968). Numerical analysis of BOD and DO profiles. J. of the Sanitary Engineering Division, ASCE, 94, SA5, 789-807.

Eckenfelder, W.W. and J. McCabe (1960). Process design of Biological oxidation systems for industrial waste treatment. Proc 2nd Symp. on Treatment of Wastewaters, Pergamon press, N.Y., 156-187.

Eckenfelder, W.W. (1966). Industrial Water Pollution Control. McGrawHill N.Y.

Ericsson, B., B. Hultman, Å. Stenberg (1970). Aktivslamprocessen. Litteraturstudier över aerob slamstabilisering. Publ. 70:7. Inst. för Vattenförsörjnings- och avloppsteknik samt inst. för Vattenkemi, KTH, Stockholm (in Swedish).

Fair, G.M., J.C. Geyer and D.A. Okun (1968). Water and Wastewater Engineering: Volume 2. Wiley.

- Fan, L.T., P.S. Shah, N.C. Pereira and L.E. Erickson (1973). Dynamic analysis and optimal feedback control synthesis applied to biological waste treatment. *Water Research*, 7, 1609-1641.
- Ford, D.L. and W.W. Eckenfelder, Jr. (1967). The Role of Enzymes in the Contact Stabilization Process - Discussion. *Advances in Water Pollution Research*, Vol. 2. Article by Siddiqi, R.H., R.S. Engelbrecht and R.E. Speece, Water Pollution Control Federation, Washington.
- Gaudy, A.F. Jr. and E.T. Gaudy (1971). Biological concepts for design and operation of the activated sludge process. U S Environmental Protection Agency, Water Pollution Control Research Series 17090 FQJ 09/71.
- Gunsalus, I.G. and R.Y. Stainer, eds. (1962). *The Bacteria*, vol 4. *The Physiology of Growth*, Academic Press, N.Y..
- Gustafsson, B., N. Westberg, B. Ericsson, B. Hultman (1970). Aktivslamprocessen under preciserade betingelser. Sammanfattande rapport. Publ 70:2, Inst för Vattenförsörjnings- och avloppsteknik samt Inst. för Vattenkemi, Kungl. Tekn. Högskolan, Stockholm (in Swedish).
- Hawkes, H.A. (1963). *The Ecology of Wastewater Treatment*. Pergamon Press, Oxford.
- Hilmer, A., B. Gustafsson, N. Westberg (1964). Aktivslamprocessen under preciserade betingelser II. Översikt över aktivslamprocessens mikrobiologi och biokemi (in Swedish). Publ. 64:2, Inst. för Vattenförsörjnings- och avloppsteknik samt Inst. för Vattenkemi, Royal Inst. of Technology, Stockholm, Sweden.
- Hultman, B., Å. Stenberg and A. Widell (1972). Kinetic Studies of the effect of Toxic substances on activated sludge. Paper, KEMTEK 2, Scandinavian congress of chemical engineering, Copenhagen, Nov. 2-4.

Hultman, B. (1975). Modeling of microbial growth in wastewater treatment. Journal of water pollution control federation, April.

Jacquart, J.C., D. Lefort and J.M. Rovel (1973). An attempt to take account of biological storage in the mathematical analysis of activated sludge behaviour. Advances in water pollution research (Jenkins, S.H. ed.) Pergamon Press, New York.

Jones, P.H. (1971). A mathematical model for contact stabilization - Modification of the activated sludge process. Advances in Water Pollution Research, Vol. 1. (Jenkins, S.H. ed.) Pergamon Press, New York.

Jones, G.L. (1973). Bacterial growth kinetics: Measurement and significance in the activated sludge process. Water Research, 7, 1475-1492.

Keinath, T.M. (1974). Automation of Physical and chemical processes. Workshop on Research needs for automation of wastewater treatment systems, Clemson University, Clemson S.C., Sept. 22-25.

Kynch, G.J. (1952). A Theory of Sedimentation. Transactions. Faraday Society. 48, 166.

Lamanna, C. and M.F. Mallette (1965). Basic Bacteriology - It's Biological and chemical background. Williams and Wilkins, Baltimore.

Manahan, S.H. (1972). Environmental Chemistry, Willard Grant Press, Boston, USA.

McCarty, P.L. (1971). Energetics and bacterial growth. In "Organic compounds in aquatic environments", S.D. Faust and J.V. Hunter, Eds, Marcel Dekker, Inc, New York.

McCarty, P.L. (1972). Energetics of organic matter degradation. In "Water pollution microbiology", R. Mitchell, Ed., Wiley-Interscience, New York.

McKinney, R.E. (1962). Microbiology for sanitary engineers. McGraw Hill, N.Y.

McKinney, R.E. (1963). "Mathematics of Complete-Mixing Activated Sludge". Transactions, ASCE. 128, 497.

McKinney, R.E. (1963). Advances in Biological Waste treatment. Pergamon Press, N.Y.

Mc Lellan, J.C. (1969). Aspects of the response of a mixed microbial culture to variations in loading. Ph.D. dissertation, Rice Univ., Houston, Texas.

Metcalf & Eddy (1972). Wastewater Engineering, McGraw Hill.

Mikesell, R.D. (1971). Theoretical analysis of activated sludge dynamics. Journal of the Sanitary Engineering Division, American Soc. of Civil Engineers, vol. SA5, 773-781.

Monod, J. (1942). Recherches Sur La Croissance des Cultures Bacteriennes. Herman et Cie, Paris.

Morris, J.C. and W. Stumm (1960). Colloidal aspects of waste treatment. Proc. Rudolphs res. conf., Rutgers Univ.

Mueller, J.A., W.C. Boyle and E.N. Lightfoot (1968). Oxygen diffusion through Zooglocal flocs. Biotechnology and Bioengineering, Vol X, 331-358.

Murphy, K.L. and P.L. Timoney (1966). Axial dispersion in aeration tanks. Proc. First Symp. on Water Pollution Research, Univ. of Waterloo, Waterloo, Ontario, Canada.

Murphy, K.L. (1970). The significance of flow patterns and mixing in biological waste treatment. Amer. Chem. Soc. meeting, Chicago, Ill., Sept. 11-13.

Naito, M., T. Takamatsu and L.T. Fan (1969). Optimization of the activated sludge process p optimum volume ratio of aeration and sedimentation vessels. Water Research 3, 433-443.

Oginsky, E.L. and W.W. Umbrett (1959). An Introduction to Bacterial Physiology. W.H. Freeman and Co., San Francisco.

Olsson, G., K.I. Dahlqvist, K. Eklund and L. Ulmgren (1973). Control Problems in Wastewater treatment. Report. The Axel Johnson Institute for Industrial Research. Nynäshamn, Sweden.

Olsson, G. (1974). Measurement and control in chemical and environmental engineering. Invited survey paper, Scandinavian congress on chemical engineering, KemTek 3, Copenhagen, Danmark, Jan 29.

Ott, C.R. and R.H. Bogan (1971). Theoretical analysis of activated sludge dynamics. J. of the Sanitary Eng. Div., Proc. of the Amer. Soc. of Civil Engrs., vol SA 1, 1-17.

Poduska, R.A. and J.F. Andrews (1974). Dynamics of nitrification in the activated sludge process. 29th Industrial Waste Conf., Purdue Univ., Lafayette, Indiana, May 7-9, 1974.

Rich, L.G. (1973). Environmental Systems Engineering, McGraw Hill.

Smith, H.S. (1963). Oxygen uptake in a completely mixed activated sludge system. Ph.D. dissertation, Iowa State Univ., Ames.

Smith, R. and R.G. Eilers (1969). A generalized computer model for steady-state performance of the activated sludge process. US Dept. of the Interior, Federal Water Pollution Control Administration, Cincinnati, Ohio, October 1969.

Smith, R. and R. Eilers (1970). Simulation of the time dependent performance of the activated sludge process. US Department of the Interior, Federal Water Quality Administration, Advanced Waste Treatment Branch, Cincinnati, Ohio, October 1970.

Smith, R. and R. Eilers (1974). Control schemes for the activated-sludge process. National Environmental Research Center, EPA, Cincinnati, report EPA-570/2-74-059.

Stainer, R.G., M. Doudoroff and E.A. Adelberg (1958). General Microbiology. McMillan Co., London.

Stewart, M.J. (1971). Activated sludge system variations - Specific applications. W&SW, Reference number R7-R22.

Takahashi, S., T. Fujita, M. Kato, T. Saiki and M. Maeda (1969). "Metabolism of Suspended Matter in Activated Sludge Treatment". Advances in Water Pollution Research. (Jenkins, S.H., ed.), Pergamon Press, New York.

Teissier, G. (1936). Les Lois Quantitatives de la Croissance. Anna. Physiol. Physicochim. Biol., 12, 527-585.

Thomann, R.V. (1967). Systems analysis and simulation in Water Quality management. Proc., IBM Scientific symposium on water and air resources management; 223-233.

Tracy, K.D. (1973). Mathematical Modeling of Unsteady State Thickening of Compressible Slurries, Ph.D. Dissertation, Clemson University, Clemson, South Carolina.

Tracy, K.D. and T.M. Keinath (1973). Dynamic model for clarification and thickening of activated sludge. Amer. Inst. of Chem. Engrs., Symposium series, Water, Symposium series 136, vol. 70, 291.

Walters, C.F. (1966). Biochemical storage phenomena in activated sludge. Ph.D. dissertation, Univ. of Illinois, Urbana, Ill.

Varma, M.M. H.E. Finley and G.H. Bennett (1975). Population dynamics of protozoa in wastewater. Journal Water Pollution Control Federation, 47, 1, 85-92.

Wells, C.H. and D.E. Stepner (1972). Automatic control of dissolved oxygen in the Palo Alto Regional Wastewater treatment plant. Paper, session 12, 65th Annual Meeting of the AIChE, New York, Nov. 26-30, 1972.

Westberg, N. (1967). A study of the activated sludge process as a bacterial growth process. *Water Research*, 1, 795-804.

Westberg, N. (1969). An introductory study of regulation in the activated sludge process. *Water Research*, 3, 613-621.

Westberg, N. (1972). Optimerad aktivslamrening (in Swedish) *Teknisk tidskrift*, 102, 1, Jan 1972.

Einsele, A. and A. Fiechter (1971). Liquid and Solid Hydrocarbons. *Advances in Biochemical Engineering 1* (edited by T.K. Ghose and A. Fiechter). Springer Verlag.

Gujer, W. and D. Jenkins (1975). The contact stabilization activated sludge process - oxygen utilization, sludge production and efficiency. *Water Res.*, 9, 553-560.

Lee, S.S., A.P. Jackman and E.D. Schroeder (1975). A two-state microbial growth kinetics model. *Water Research*, 9, 491-498.

Neame, K.D. and T.G. Richards (1972). *Elementary kinetics of Membrane Carrier Transport*. Blackwell Scientific Publications, Oxford, London.