



LUND UNIVERSITY

Freeze-thaw and de-icing resistance of concrete : research seminar held in Lund, June 17, 1991 : RILEM committee TC-117 FDC

Fagerlund, Göran; Setzer, Max

1992

[Link to publication](#)

Citation for published version (APA):

Fagerlund, G., & Setzer, M. (Eds.) (1992). *Freeze-thaw and de-icing resistance of concrete : research seminar held in Lund, June 17, 1991 : RILEM committee TC-117 FDC*. (Report TVBM 3048). Division of Building Materials, LTH, Lund University.

Total number of authors:

2

General rights

Unless other specific re-use rights are stated the following general rights apply:

Copyright and moral rights for the publications made accessible in the public portal are retained by the authors and/or other copyright owners and it is a condition of accessing publications that users recognise and abide by the legal requirements associated with these rights.

- Users may download and print one copy of any publication from the public portal for the purpose of private study or research.
- You may not further distribute the material or use it for any profit-making activity or commercial gain
- You may freely distribute the URL identifying the publication in the public portal

Read more about Creative commons licenses: <https://creativecommons.org/licenses/>

Take down policy

If you believe that this document breaches copyright please contact us providing details, and we will remove access to the work immediately and investigate your claim.

LUND UNIVERSITY

PO Box 117
221 00 Lund
+46 46-222 00 00



Lund Institute of Technology

Division of Building Materials

RILEM Committee TC-117 FDC

FREEZE-THAW AND DE-ICING RESISTANCE OF CONCRETE

Research seminar held in Lund, June 17, 1991

Edited by:

Göran Fagerlund

Max Setzer

Report TVBM-3048

Lund, 1992

CODEN : LUTVDG/(TVBM-3048)/1-166/1992/

ISSN 0348-7911

RILEM Committee TC-117 FDC

FREEZE-THAW AND DE-ICING RESISTANCE OF CONCRETE

Research seminar held in Lund, June 17, 1991

Edited by:

Göran Fagerlund

Max Setzer

Report TVBM-3048

Lund, February 1992

CONTENTS	Page
Preface	3
Max Setzer: Basic Phenomena of Frost Action.	5
Takashi Miura; Do Heun Lee: Deformation and Deterioration of Concrete at low Temperatures.	19
Göran Fagerlund: Studies of the Scaling, the Water Uptake and the Dilation of Mortar Specimens exposed to Freezing and Thawing in NaCl-solution.	35
Volker Hartmann: Experiences with an improved Freeze-thaw and De-icing Test.	67
Erik J. Sellevold; Tom Farstad: Frost/Salt Testing of Concrete. Effect of Test Parameters and Concrete Moisture History.	81
Per-Erik Petersson: Scaling Resistance of Concrete. Testing according to SS 13 72 44.	101
T.A. Harrison; R.Sym: Freeze/thaw Type Approval Testing.	117
Werner Studer: Experiences with the Critical Degree of Saturation Method to measure Frost Resistance of Concrete.	129
Jochen Stark; Host-Michael Ludwig: The Effects of low Temperature and Freeze-Thaw Cycles on the Stability of Hydration Products.	137
Jochen Stark; Sylvia Stürmer: The Influence of the C ₃ A-content on the Durability at Freezing and Thawing.	153

Preface.

The RILEM Committee TC-117 FDC -Freeze-Thaw and De-icing Resistance of Concrete- started its work with a first meeting that was held in Essen in May 1990. A second meeting was held in Brighton in November the same year.

During both meetings, some differences in opinion were disclosed concerning the effects of different external and internal factors on the de-icing resistance and concerning the manner in which a relevant de-icing resistance test should be made. Therefore, it was decided that a one-day seminar should be held during the third meeting of the committee in order to give the committee members the possibility to present their results and to express their opinion concerning the salt-scaling problem. This third meeting was held in Lund on June 27-28, 1991. The research seminar was held on the first day of the meeting.

This report contains all the manuscripts that were delivered by the speakers after the seminar. Some oral presentations were not followed by written manuscripts, however. Some manuscripts included in this report have been or will be published elsewhere.

We think that this collection of papers will be of considerable value for the future work within the RILEM Committee and also for other research workers which take interest in the salt-scaling problem.

Göran Fagerlund
Professor
Lund Institute of Technology

Max Setzer
Professor
University of Essen
Chairman of RILEM Committee TC-117 FDC

BASIC PHENOMENA OF FROST ACTION

Max Setzer

University of Essen
Essen, Germany

BASIC PHENOMENA OF FROST ACTION

Prof. Setzer

University Essen, Universitätsstr. 15, W-4300 Essen 1, Germany

ABSTRACT

The special behaviour on freezing and thawing of pore solution in concrete is outlined. Special attention is given to the non-macroscopic effects. The amount of freezable water, the effect of desorption, the influence of deicing chemicals and transport phenomena are discussed. Conclusions for the test procedures are drawn.

1. INTRODUCTION

The freeze thaw and deicing salt test can only be optimized properly and developed into a reliable procedure if the factors affecting the results are analysed on the basis of the physical behaviour of pore water and the microstructure of concrete. It deviates from macroscopic experience significantly due to the highly dispersed microstructure. Especially the freezing point of pore water is depressed significantly depending on pore size and salt content. Changes in surface tension lead to additional stress. The transport phenomena of water and of dissolved ions in the structure are complex.

Up to now in testing the freeze thaw durability it has been primarily attempted to copy outdoor conditions in the laboratory. However this is possible only in a very restricted manner since climatic variations are extremely high. The reaction of concrete to the changes in environmental conditions are only predictable if the special microstructural behaviour is taken into account. The the amount of freezable pore water depends on the degree of water saturation, temperature, structure and the concentration of the dissolved deicing chemicals in concrete. If during the test one of these parameters is allowed to vary the test result will be unpredictable.

In the following contribution a short summary of the present basic knowledge will be outlined and the necessary conclusions shown.

2. FREEZING OF PORE WATER

Both a depression of freezing point and a supercooling of pore water are observed. The depression of freezing point is reproducibly dependent on the microstructure and surface physics. Supercooling is a statistical effect with a random decrease in freezing point dependent on heterogeneous and homogeneous nucleation processes during the cooling period.

For the depression of freezing point the Clausius Clapeyron equation (1)

$$\frac{\delta p}{\delta T} = \frac{\Delta h}{T \Delta v} \quad (1)$$

$$\Delta s \delta T = \Delta v \delta p \quad (1a)$$

must be modified by a term taking into account the change of surface energy during freezing.

$$\Delta s \delta T = \Delta v \delta p - (v_i \gamma_{si} - v_l \gamma_{sl}) \delta(1/R_h) \quad (2)$$

$$\approx -v_l (\gamma_{si} - \gamma_{sl}) \delta(1/R_h) = -v_l \Delta \gamma \delta(1/R_h) \quad (2a)$$

In these equations Δh is the molar heat of fusion, Δs , Δv and $\Delta \gamma$ are the change of molar entropy, molar volume and specific surface free energy on freezing respectively. γ is the specific surface free energy, T the absolute temperature, v the molar volume and R_h the hydraulic radius i.e. the volume to surface ratio. The index l stand for liquid water, i for ice and s for the solid matrix. γ_{sl} is therefore the specific surface free energy between solid matrix and pore water.

If the molar heat of fusion $\Delta h = \Delta s/T$ is constant and if a cylindrical pore shape is assumed (pore radius $r = 1/2 * R_h$) equation 2a can be integrated to

$$\ln \left[\frac{T}{T_0} \right] = - \frac{2 \Delta \gamma v}{\Delta h r} \quad (3)$$

which is the Volmer equation for depression of freezing point [18]. In concrete neither Δh is constant nor the shape is cylindrical. Therefore equation 2a has to be

M. J. Setzer: Basic Phenomena of Frost Action

integrated numerically. An attempt has been made by Brun et. al. [8]. Here too a temperature dependency of $\Delta\gamma$ is found for water ¹

$$\Delta\gamma = \{40,9 + 0,39 (T - T_0)\} \text{ mJ/m}^2 \quad (4)$$

Brun et al. also took into account the entropy change of phase transition with temperature as can be calculated on the basis of the heat capacities of bulk water and ice. The depression of freezing point on this basis is plotted in figure 1.

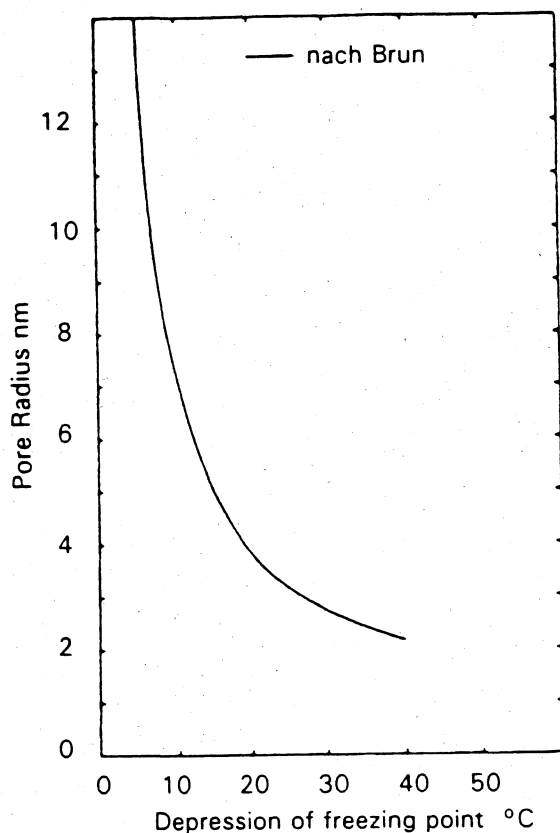

Figure 1. Depression of freezing point in porous systems following Brun et al. [8].

Differential scanning calorimetry (DSC) is used to determine freezing and melting points as well as enthalpies and heat capacities. Sellevold and Bager [3] have studied hardened cement paste (hcp) adopting this method. We have used the combination of water vapour sorption and DSC to correlate pore water content, pore size distribution and freezing points [9,16]. It was found that on desorption below 50 % r.h. no phase

¹ These rather small values can only be explained if an unfrozen water layer between the solid and the pore ice exists. Its thickness is one to three monomolecular layers. (A discussion of this film is found in [3].) For a water droplet in air $\Delta\gamma$ would be approximately ten times larger. Therefore droplets of the same size as water in gel pores would not freeze as supposed e.g. by [2].

transition is observed, i.e. all transitions can be attributed to "prestructured condensate" in accordance with the thermodynamic considerations. The naming of this water is justified by the following DSC analysis.

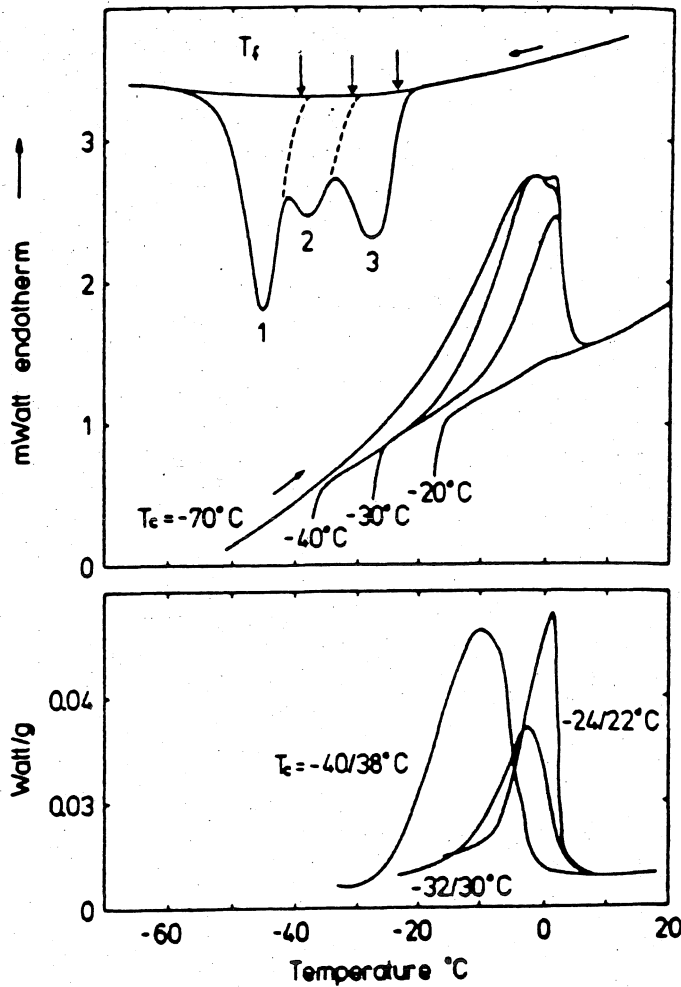

Figure 2. DSC plots of scanning cycles with different reversal temperatures T_c and three characteristic difference plots of heating curves (hcp, w/c=0,5, stored at 96% r.h.)

		A	B	C
T_f	°C	-39,4	-31,0	-23,7
E_f	J/g	4,7	2,8	3,0
T_m	°C	-24,6	-14,0	-9,2
E_m	J/g	2,5	0,7	0,8
f	-	1,7	2,3	2,7

Table 1. Transition temperatures T (freezing f, melting m), transition energies E related to the specimen weight, and shape factor f for the phase transitions A, B, C of prestructured condensate [7].

We have recently developed a cyclic scanning method to desmear the heating curves [5,6,7]. Thus the enthalpy changes during heating can be resolved and compared. For this purpose cooling and heating cycles were measured between 20°C and a lower

reversal temperature T_c . The reversal temperature was increased with every cycle from -70°C to 0°C in steps of 2°C .

The difference curves are obtained by subtracting two adjacent heating curves - in the plot they are characterised by the two reversal points. Using this procedure we found three distinct phase transitions of pore water (table 1) in addition to the normal bulk transition and the second order transition of adsorbed films at -90°C .

The transition enthalpies the pore water itself can only be estimated since it is not easy to determine the correct amount of water which freezes at each transition point. Values of about 80 J/g (pore water) were calculated. This is much less than expected from macroscopic calculations (e.g. after Brun et al. 126, 155 and 187 J/g for the transitions A, B, C respectively). Thus the entropy change during freezing is much less than assumed in a semi-macroscopic calculation. X-ray diffraction investigations [2] prove that the pore ice is normal ice I_h . The entropy of pore water must therefore be smaller. This is reasonable since the water in adsorbed films is highly structured as stated in [1] for adsorbed films. For water it is assumed by [20] that on the internal surfaces there are one to three molecular layers which are strongly structured by the surface interaction followed by a disordered 'mismatch zone'. Further from the surface the water assumes bulk properties characterised by clusters of molecules connected by hydrogen bonds. Bulk water is e.g. described by the flickering cluster model of Nemethy and Scheraga [13]. The structuring explains both the reduced transition energies and the distinct phase transitions. It would also mean that there are stable and less stable structures depending on pore size.

3. DESORPTION AND FREEZING

Similar to freezing capillary, condensation depends on the pore radius. Taking into account the surface film a modified Kelvin equation is found for condensation

$$R_h = \frac{(\gamma_w + \Delta\gamma_s) v_l}{\mu} = \frac{(\gamma_w + \Delta\gamma_s) v_l}{RT \ln \left[\frac{p}{p_0} \right]} \quad (5)$$

(where μ is the chemical potential, R is the ideal gas constant, and γ_w the surface energy of water, $\Delta\gamma_s$ a increase in surface energy due to the solid liquid surface interaction and p/p_0 the relative humidity. For more details see [15].)

Equation 3 and 5 show that water in larger pores is freezed first or desorbed first. According to this macroscopic approach one would expect that on desorption the phase transitions should disappear at certain relative humidities (and vice versa on

adsorption) since both are related to certain pore radii. As can be seen in figure 3 the amount of water which freezes steadily reduces on desorption for all three transitions. This behaviour could be explained by microstructural changes, i.e. on desorption the total amount of mesopores reduce simultaneously. It can be explained by the action of disjoining pressure [15].

It should be kept in mind that below 50 % r.h. there is still a large amount of physically bound water in hcp. This water is contained in pores where a first order phase transition is impossible due to high prestructuring. A second order phase transition has been observed in a study of the dynamical elastic modulus [19,20].

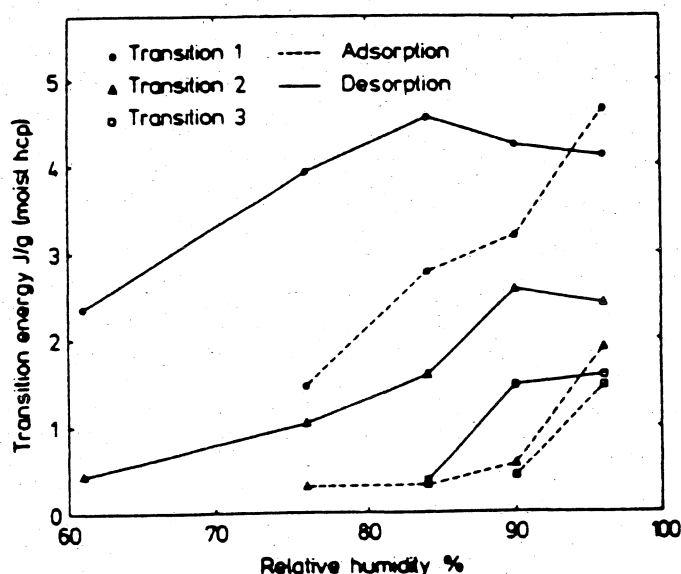

Figure 3. Heats of transitions related to the weight of the hcp sample for desorption and adsorption [7].

4. INFLUENCE OF DEICING AGENTS

Deicing agents, e.g. NaCl, influence the surface interaction significantly. From DSC studies three effects of salt concentration can be noted [4]:

1. The freezing point depression due to chlorides superimposes on the depression of freezing point due to surface interaction both for the bulk transition and the transitions of prestructured water - figure 4.
2. The transition enthalpy is lowered and the transition peaks are broadened until they vanish completely at high salt concentrations. This again can be seen as a superposition of the disturbance due to salt ions with that of surfaces. In addition, salt ions have to be transported since ice contains only negligible amounts. They

are located preferably in the unfrozen interfacial water. (The study of dynamical elastic modulus leads to this conclusion too [20].)

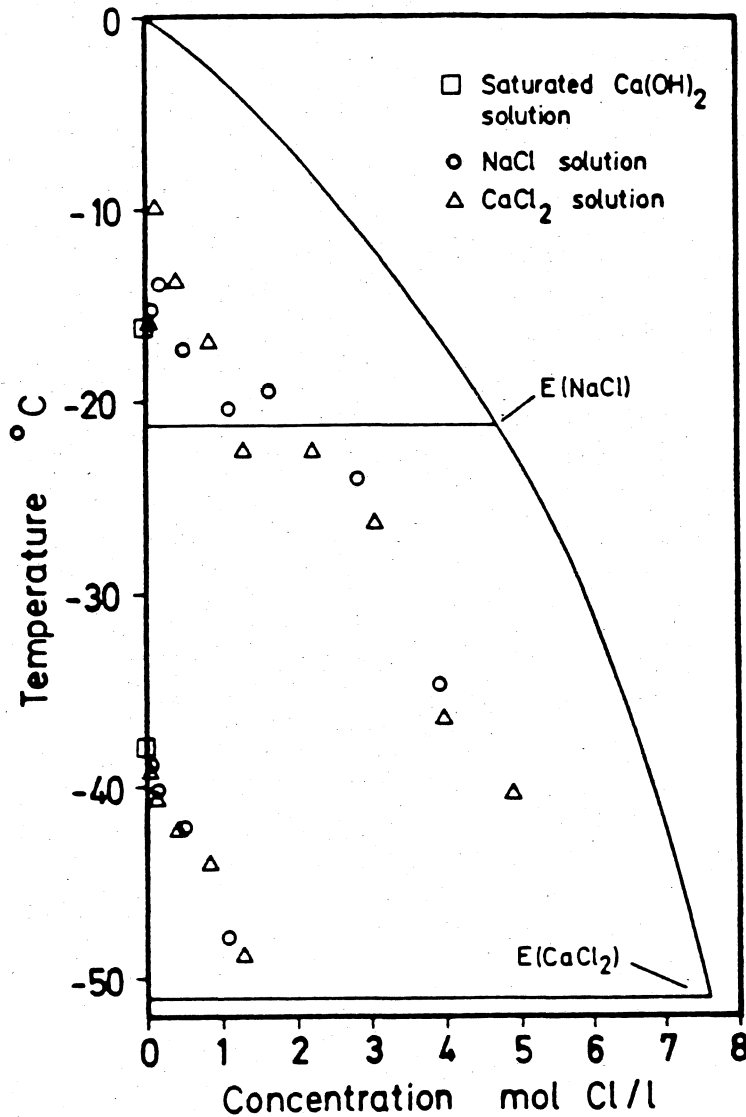

Figure 4. Bulk water freezing point and prestructured transition A (-39°C) as function of chloride ion concentration with liquidus and solidus lines for aqueous NaCl and CaCl₂ solutions [6]

3. Desorption of specimens stored in salt solutions of different concentration produced sharpening of the previously smooth s-shaped curve for the low temperature transition energy - figure 5. Two opposed effects can explain this behaviour [4]:

On desorption the concentration of the pore solution increases which lowers the transition enthalpy.

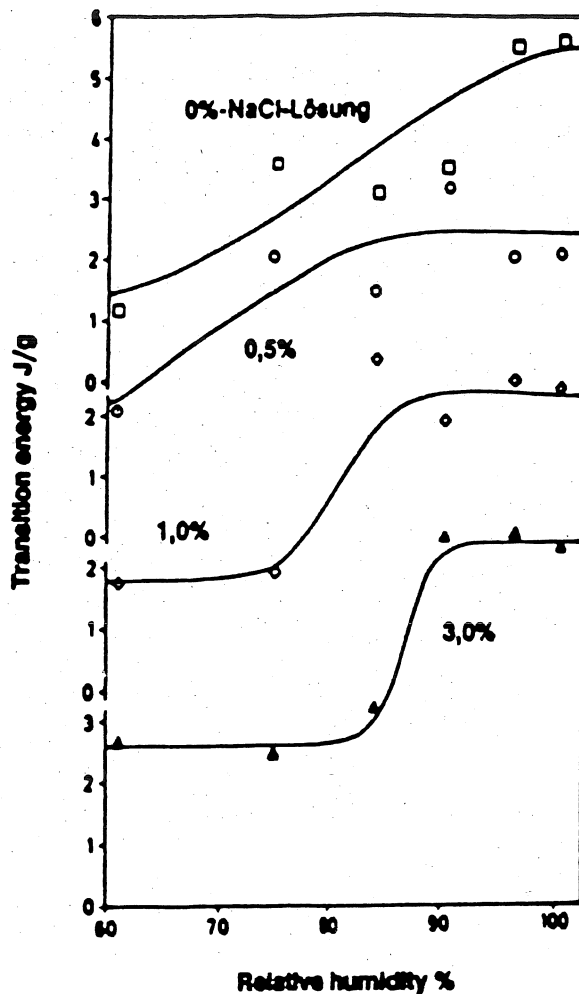

Figure 5. Transition energy of prestructured water at the transition temperature -39°C as a function of relative humidity after storage in salt solutions [6].

Salt reduces the vapour pressure of the pore water causing emptying to occur at lowered relative humidities.

Above a concentration of about 1 mole Cl/l no change of this enthalpy is found; the transition vanishes.

5. TRANSPORT OF WATER AND DEICING CHEMICALS

There are several transport phenomena superimposed during frost action. Therefore only the most significant points are considered. Volkwein [17] has discussed this subject in detail.

1. If the relative humidity is below the saturation point, water vapour transport occurs. In larger pores this gas transport is only depends on the pore volume and the difference in vapour pressure. The pore size distribution can be neglected

M. J. Setzer: Basic Phenomena of Frost Action

until the mean free path length of a water molecule is smaller than the pore radius. In smaller pores a Knudsen flow takes place which can be neglected. However as a rule these pores contain condensed water. Therefore here transport takes place in the liquid.

2. The most efficient transport is in the liquid phase. It can be generated e.g. either by pressure or temperature differences or by capillary suction.

The temperature difference causes a transport from hot to cold. Since under normal test conditions there is always a considerable amount of unfrozen water, this type of transport is possible even below 0° C. If in a test procedure the temperature gradient in the specimen is not defined, an unknown transport occurs. Therefore a lateral thermal isolation is meaningful with a defined uniaxial cooling and heating.

Capillary suction is a physically well defined process. It is therefore advantageous to produce a defined degree of saturation.

On freezing it must be taken into account that the coefficient of thermal expansion of water is nearly one order of magnitude larger than that of ice or of the solid matrix. Therefore a pumping effect due to this must be considered especially if the anomaly of water on freezing and the hysteresis between freezing and thawing is taken into account.

Deicing chemicals can be sucked up with water or diffuse within the water following a concentration gradient. However, Volkwein [17] showed that the coefficient of diffusion is so extremely small, that a diffusion process is as a rule completely surpassed by other phenomena, e.g. suction due to hydration even in mature concrete. Therefore if the specimen is nearly water saturated an uptake of deicing chemicals is mostly related to second order effects which cannot be controlled precisely enough by a test procedure.

6. CONSEQUENCES FOR TEST PROCEDURES

On the basis of the characteristic behaviour of pore solution during freezing and thawing some conclusions for testing can be drawn.

1. The amount of freezable water must be taken into account. Fagerlund [11] has already made clear that a critical degree of saturation exists. For a test procedure a defined degree of saturation should be established. This can be achieved e.g. by capillary suction. Previously the sample should be stored so that the freezable water is removed at least near the surface. Drying at relative humidities below

M. J. Setzer: Basic Phenomena of Frost Action

60% is sufficient for this. I.e. no special clima chamber is necessary. Laboratory conditions are sufficient.

2. The minimum temperature at the tested surface is essential since it defines the ratio of frozen and unfrozen water. The deviation from minimum temperature should be kept as small as possible. A tolerance below ± 0.5 K seems realistic - it must be below ± 1 K.
3. The temperature attack should be uniaxial. Therefore all the sides of the specimen except the tested surface must be thermally isolated. Otherwise the temperature gradient especially in air cooled clima chambers is unpredictable. (Cooling could take place over the bottom side too.)
4. The deicing chemicals must be sucked up with the water. Diffusion processes are too uncertain. Therefore presaturation of the specimen with water is not meaningful.
5. A 3% sodium chloride solution is most detrimental.

7. LITERATURE

1. Badmann, R.; Stockhausen, N.; Setzer, M.J.: "The statistical thickness and chemical potential of adsorbates", *J Colloid Interface Sci.* 82 (1981) 534
2. Badmann, R.: "Das physikalischgebundene Wasser des Zementsteins in der Nähe des Gefrierpunkts" (The physically bound water of hcp near freezing point), PhD thesis, Techn. Univ. Munich, 1981
3. Bager, D.H.; Sellevold, E.J.: "Ice formation in hardened cement paste" *Cem. Concr. Res.* 16, 709 (1986), *Cem. Concr. Res.* 16, 835 (1986)
4. Beddoe, R.E.; Setzer, M.J.: "Chloride action on hardened cement paste - a DSC study", *Proc. DFG-Coll. Durability of non-metallic inorganic building materials*, Univ. Karlsruhe, 1988
5. Beddoe, R.E.; Setzer, M.J.: "A low-temperature DSC investigation of hardened cement paste subjected to chloride action", *Cem. Concr. Res.* **18**, (1988) 249
6. Beddoe, R.E.; Setzer, M.J.: "Phase transformation in hardened cement paste - a low-temperature DSC investigation", *Cem. Concr. Res.* **20**, (1990) 235
7. Beddoe, R.E.; Setzer, M.J.: *Forschungsberichte aus dem Fachbereich Bauwesen, Universität GH Essen*, Vol. **49** (1990)

M. J. Setzer: Basic Phenomena of Frost Action

8. Brun, M.; L'Allemand, A.; Quinson, J.-F.; Eyraud, C.: "A new method for the simultaneous determination of the size and shape of pores: The thermoporometry" *Thermochimica Acta* **21** (1977) 59
9. Dorner, H.; Setzer, M.J.: "Tieftemperatur-DTA-Untersuchungen des Zementsteingefüges bei unterschiedlichem Hydratationsgrad" (Low temperature DTA-studies of hcp at different degree of hydration), *Cem. Concr. Res.* **10**, (1980) 403
10. Drost-Hansen, W.: "Structure of water near solid interfaces" *Industrial & Engineering Cem.* **61** (1969) 10
11. Fagerlund, G.: The critical degree of saturation method of assessing the freeze-thaw resistance of concrete. *Materials And Structures*; **10** (1977) 58, p. 217 - 229.
12. Litvan, G.G.: *Can. J. Chem.* **44**, (1966) 2617
13. Nemethy, G.; Scheraga, H.A.: "Structure of water and hydrophobic bonding in proteins. I. A model for the thermodynamic properties of liquid water", *J. chem. Phys.* **36** (1962) 3382
14. Setzer, M.J.: "Einfluß des Wassergehaltes auf die Eigenschaften des erhärteten Betons", *Habilitationsschrift*, 1976 Technische Universität München, erschienen in: *Schriftenreihe DASTb. Heft 280* (1977) 43-117
15. Setzer, M.J.: "Interaction of water with hardened cement paste", *Ceramic Transactions Vol. 16 "Advances in cementitious materials"*, Amer. Cer. Soc., 1990 p. 415
16. Stockhausen, N.; Dorner, H.; Zech, B.; Setzer, M.J.: "Untersuchungen von Gefriervorgängen in Zementstein mit Hilfe der DTA", *Cem. Concr. Res.* **9** (1979) 783
17. Volkwein, A.: PhD thesis, TU München, 1991
18. Volmer, M.: "Kinetik der Phasenübergänge", Th. Steinhoff Verlag, Dresden & Leipzig, 1939
19. Zech, B.; Setzer, M.J.: "The dynamic elastic modulus of hardened cement paste. Part I: A new statistical model - water and ice filled pores", *Materials & Structures* **21** (1988) 323
20. Zech, B.; Setzer, M.J.: "The dynamic elastic modulus of hardened cement paste. Part II: Ice formation Drying and pore size distribution", *Materials & Structures* **22** (1989) 125

DEFORMATION AND DETERIORATION OF CONCRETE AT LOW
TEMPERATURES*

Takashi Miura
and
Do Heun Lee

Tohoku University
Sendai, Japan

CONCRETE LIBRARY OF JSCE NO.17, JUNE 1991

DEFORMATION AND DETERIORATION OF CONCRETE
AT LOW TEMPERATURES

(Reprint from Proceedings of JSCE, No.420, 1990)



Takashi MIURA

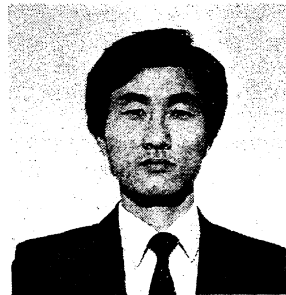

Do Heun LEE

SYNOPSIS

Under low temperatures, some concrete structures suffer serious deterioration. This is due to the ice formation in concrete micropores, which causes microcracking and loosens concrete microstructure. Based on this observation, we investigated deterioration of concrete subjected to cyclic cooling and heating of various temperature ranges. The two major findings are: (1) residual strain of concrete is in good correlation to its relative dynamic modulus of elasticity and (2) there are well-defined temperature ranges which govern the progress of deterioration. Qualitative and quantitative analyses are made on these observations.

T. MIURA is professor of civil engineering at Tohoku University, Sendai, Japan. He received his Doctor of Engineering Degree in 1980 from Tohoku University. His research interests include properties of reinforced concrete at very low temperatures, durability of cryogenic concrete, durability of reinforced concrete members, and cracking phenomena in steel framed reinforced concrete. He is a member of American Concrete Institute, Japan Society of Civil Engineers, and Japan Concrete Institute.

D.H. Lee is research associate of civil engineering at Tohoku University, Sendai, Japan. He received his Doctor of Engineering Degree in 1991 from Tohoku University. His research interests include durability of concrete structures. He is a member of Japan Society of Civil Engineers.

1. INTRODUCTION

Durability is one of the indispensable properties required for a concrete structure. However, concrete deteriorates under various severe environments, such as repetition of freezing and thawing. There are a number of concrete structures under environments which may cause serious deterioration.

In a cold region, a concrete structure is subjected to freezing and thawing. Even in a warm region, a particular concrete structure is used under low temperatures; for example, a storage tank of LNG (boiling point -162°C) or LPG (boiling point -45°C), a barge hull, or secondary structures to prevent spill from a primary tank. Recently, materials indicating superconductive properties near boiling point (-196°C) of Nitrogen have been developed. Concrete will be applied at least, as a part of a structure which bears low temperature loads, such as a Superconductive Magnetic Energy Storage (SMET).

Concrete changes its mechanical properties in various aspects when it is cooled till very low temperature. It is known that the change is mainly due to the freezing of water in concrete; since phase transition from water to ice leads to about 9% expansion by volume, internal microcracks are initiated in concrete. And repetition of cooling and heating progress the deterioration of concrete, by continuous initiation or propagation of the cracks.

Deterioration of concrete is influenced by a range of temperature cycles, i.e. what temperature it is cooled and what temperature it is warmed. It is shown that although concrete can expand even under cooling, it shrinks almost linearly to temperature decrease below -50°C ; see [1],[2]. Hence, the temperatures which causes considerable deterioration in concrete is to lie between normal temperature and -50°C .

Based on this observation, we investigated deformation and deterioration of concrete when it was subjected to cyclic cooling and heating of various temperature ranges between normal and -70°C . All experiments were carried out in air such that water would not be absorbed into concrete specimens, and nondurable Non-AE concrete was used to accelerate deterioration.

Non-linear strain behavior under cooling may be viewed as a sign indicating deterioration, since it reflects internal expansion due to ice formation. Therefore, measuring strain behavior for cement paste, mortar, and aggregate under cooling and heating, and we monitored their deterioration such that their contribution to the concrete deteriorations could be clarified.

2. TEST PROCEDURE

In the present experiments, we used high early strength portland cement similar to ASTM Type III (specific gravity: 3.13), fine aggregate (specific gravity: 2.56), and crushed stone coarse aggregate (specific gravity: 2.87). Mix proportions of concrete are shown in Table 1, and mortar and paste used in the experiment have the same water cement ratio as concrete.

Figure 1 illustrates a typical experimental procedure. Figure 2 shows dimensions of concrete, mortar, and paste specimens which were used for strain measurements. For measurement of temperature and strains, two thermocouples were mounted, one inside and the other on a surface, and strain gages were attached on opposite surfaces. For measurement of dynamic modulus of elasticity a specimen without thermocouples and strain gages was used.

Table 1 Mix proportions of concrete

Gmax (mm)	Slump (cm)	Air (%)	W/C (%)	s/a (%)	Unit Content (kg/m ³)			
					W	C	S	G
25	11±1	2±0.5	56	42	194	346	725	1125

In order to avoid moisture losses during tests, all specimens were coated just after being taken out from a storage pool. The rate of moisture content change in concrete was observed to be less than 2% till 30th cycle, and hence the moisture loss during test was negligible.

A typical pattern of cooling and heating is shown in Figure 3. The maximum cooling and heating rate were 0.35°C/min, 0.90°C/min, respectively. During cooling, temperature difference between the surface and the inside was less than 5°C for concrete specimens, and 2°C for mortar or paste specimens.

Temperature of specimen was calculated as an average of those measured on the surface and inside (this treatment was verified from preliminary experiments which investigated internal temperature distribution of specimen). Measured

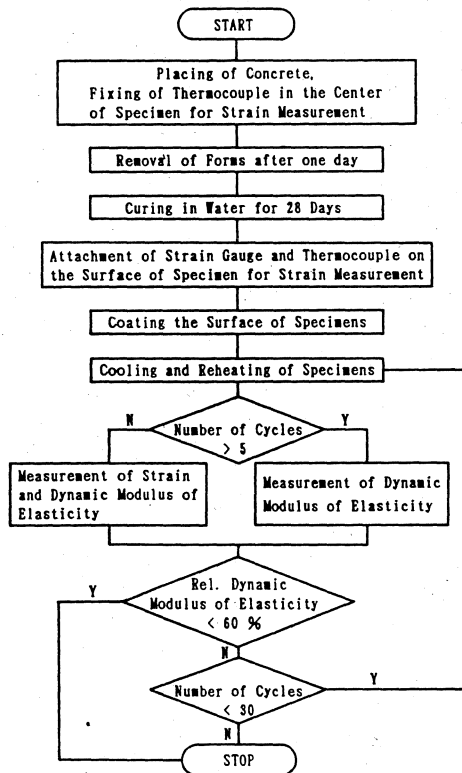
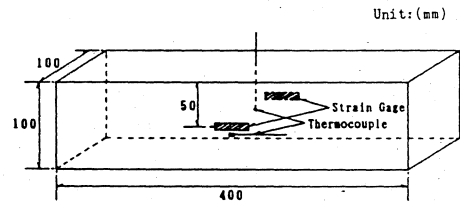

Fig.1 Flow chart of testing procedure

(a) Concrete Specimen



(b) Mortar and Paste Specimen

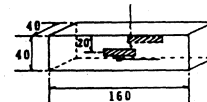

Fig.2 Prism specimens for strain measurement

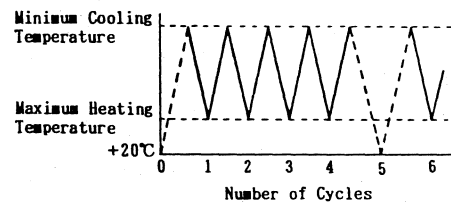

Fig.3 Temperature cycle for specimen

strain in the surface was regarded as average strain of the specimen. We considered a relation between the average strain and the average temperature.

Dynamic modulus of elasticity was measured after every five cycles and until 30th cycle. When relative dynamic modulus of elasticity was below 60%, the experiment was terminated.

3. RESULTS AND DISCUSSIONS

3.1 Theoretical background

If it is trapped in a micropores, water does not always freeze at 0°C. From measurement of enthalpy variation associated with cooling temperature on cement paste specimens, it is shown that free water freezes gradually as temperature goes down from -4°C to -90°C [3]. Depression of freezing point depends on the pore size, as shown in Figure 4 [4]; pore distribution in concrete used in this study is also presented. It should be noted that depression of freezing point is influenced by other factors, such as supercooling, chemical impurity in pore water, or surface energy interaction between water molecules and pore wall [5].

Although dried concrete exhibits a linear thermal deformation, water saturated concrete does a non-linear one. Figure 5 shows a typical strain behavior of water saturated concrete from normal to -196°C. The concrete exhibits a non-linear thermal deformation, though it only contracts in a linear fashion below -70°C [6]. Hence, we can assume that temperatures below -70°C have no considerable influence on deterioration of concrete. Based on the above facts, this study restricts cyclic temperature ranges to lie between normal and -70°C.

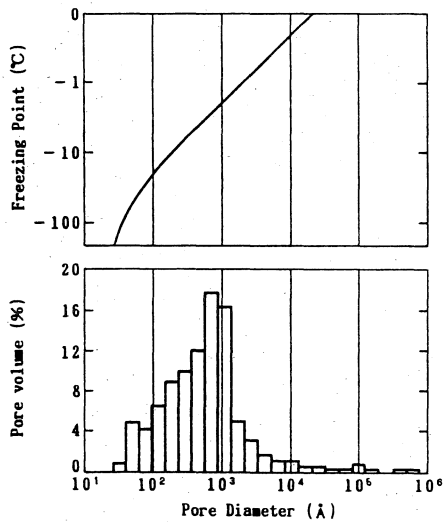

Fig.4 Relation between pore diameter and freezing point

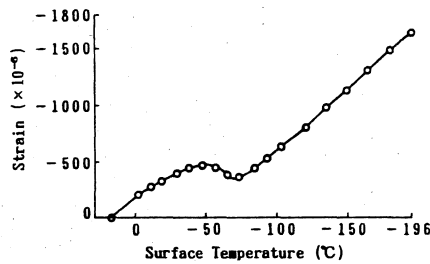

Fig.5 Typical relation between strain and surface temperature

3.2 Effect of the minimum cooling temperature

There are various temperature ranges to which a concrete structure can be subjected, and possible deterioration of concrete depends on the temperature range. To identify temperature ranges which cause serious deterioration, we

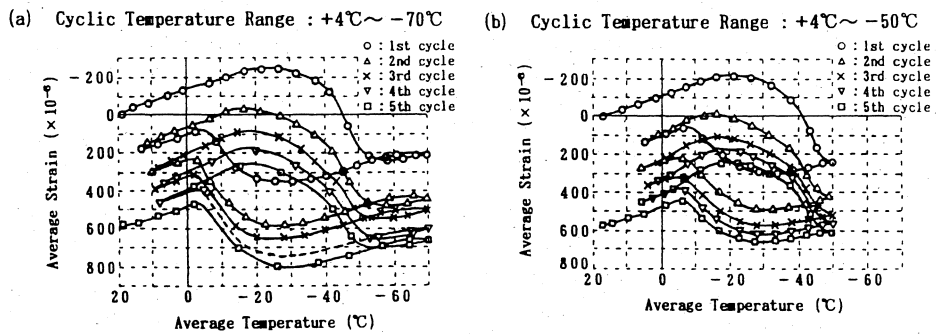

Fig.6 Relation between strain and temperature for various minimum cooling temperatures

carried out a series of experiments with varying the maximum or minimum temperatures. Figure 6 shows a typical strain behavior of water saturated Non-AE concrete under cooling and heating cycles. Major characters of the behavior are summarized [7],[8], as follows:

a) from $+20^{\circ}\text{C}$ to -20°C
 Concrete shows a almost linear contraction. It seemed that most of the water in micropores might not freeze before -20°C , and that internal stresses caused by ice formation might be released, as the surplus of frozen water in larger pores transports toward smaller pores or partially empty voids pre-existing in concrete [9].

b) from -20°C to -50°C
 Due to ice formation in almost all micropores, internal stresses become high and microcracks are initiated, showing considerable expansion of concrete. This expansion is closely related to deterioration. The amount of expansion increases as water cement ratio, moisture content, and cooling rate [7],[10-14] increases.

c) below -50°C
 Since most of water has been already frozen, concrete exhibits a linear contraction again. However, absorbed water layers on walls of very small gel pores of radius less than 3 nm do not freeze within the range of 0°C to -165°C [15].

d) on heating
 Strain behavior during heating is not the reverse of that during cooling, since melting point of water in micropores differs from freezing point. There are created residual strains, when the temperature returns to normal. It is obvious that these residual strains are a sign that internal structure of concrete is loosened.

Since residual strains indicate an amount of microcracks generated in concrete, they can be a measure for deterioration. Figure 7 shows relationship between subtraction of the residual strain of the first cycle from that of each cycle and the number of cooling and heating cycles, for experiments with different minimum temperatures and fixed maximum temperature. The residual strains increase as the cooling process is repeated, though the amount of the increased residual strain diminishes. And the residual strains tend to increase as the minimum cooling temperature decreases. However, temperatures below -50°C do not

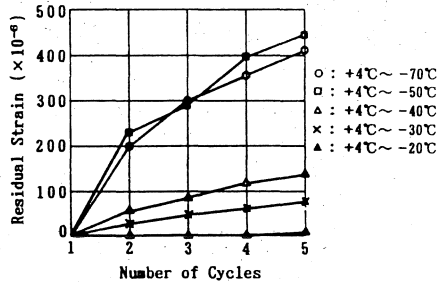

Fig. 7 Relation between residual strain and number of cycle

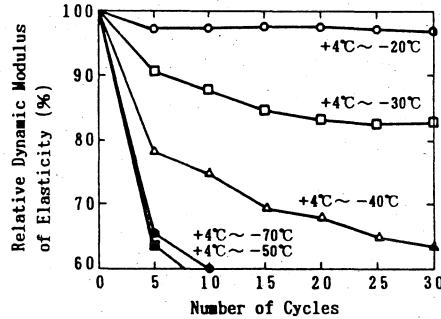

Fig. 8 Deterioration of concrete due to repetition on cooling with fixed maximum temperature and various minimum temperature

cause extra deteriorations, since the residual strains in the case of the minimum temperature -70°C as those in the case of the minimum temperature -50°C are almost the same. Concrete can be hardly deteriorated when temperature is above -20°C , since the residual strain is not observed in the case of the minimum temperature -20°C .

Based on the above results, we may set the following three ranges for the minimum cooling temperature that determine a degree of deterioration:

- i) above -20°C : concrete is hardly deteriorated
- ii) $-20^{\circ}\text{C} \sim -50^{\circ}\text{C}$: degree of deterioration increases as minimum cooling temperature decreases
- iii) below -50°C : degree of deterioration is almost constant

We consider effects of the minimum temperature on the loss of dynamic modulus of elasticity. Figure 8 shows a change of the dynamic modulus of elasticity during repetition of cooling and heating when various minimum cooling temperatures are used. It is seen that concrete is hardly deteriorated for the minimum cooling temperature -20°C , since the loss of elasticity is very small. The relative dynamic modulus of elasticity at 30th cycle is about 80% and 60%, respectively, when the minimum temperature is -30°C and -40°C . In the cases of the minimum temperature -50°C and -70°C , the degrees of deterioration are almost the same, the relative dynamic modulus elasticity is less than 60% between 5th and 10th cycle.

As for effects of minimum cooling temperatures on deterioration, we can obtain a similar tendency in the results of the dynamic modulus of elasticity and the strain behavior. The mechanism of how the minimum cooling temperature effects on deterioration may be explained as follows: microcracking and non-linear thermal deformation of concrete are induced by about 9% volume expansion due to phase transformation of water, and the amount of ice formed in concrete increases as the temperature decreases. Hence, it can be concluded that the deterioration of concrete subjected to repetition of cooling and heating, mainly occurs at the temperatures between -20°C and -50°C .

3.3 Effect of the maximum heating temperature

Although a number of papers concerning to frost damage have been reported, studies for the influence of maximum heating temperature on deterioration of

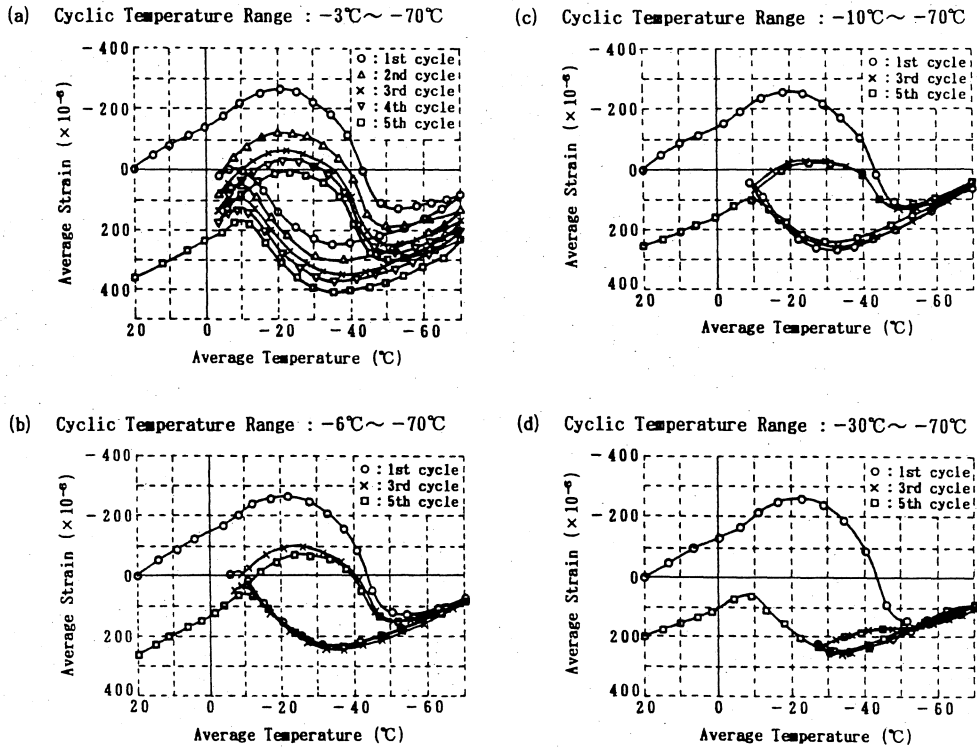

Fig.9 Relation between strain and temperature for various maximum heating temperature

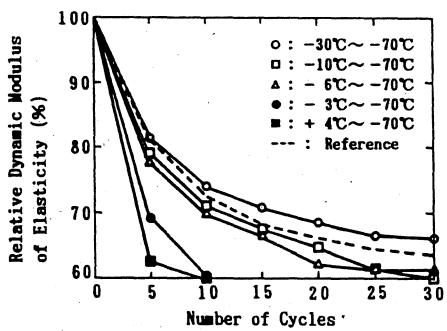

Fig.10 Deterioration concrete due to repetition of cooling with fixed minimum temperature and various maximum temperatures

concrete are still insufficient. We expect that the maximum heating temperature has a major influence of deterioration of concrete as well as the minimum cooling temperature. In this section, we investigate deterioration of concrete under temperature ranges with fixed minimum temperature and various maximum temperatures.

Figure 6 shows that concrete expands till -30°C during heating, and that it considerably contracts between -30°C and -10°C , and then expands again when the temperature is above -10°C . For cases, similar behaviors are observed; see Figures 9 where the minimum cooling temperature is -70°C and the maximum heating temperature ranges from

-30°C to $+4^{\circ}\text{C}$. It is shown that strain behavior of concrete shifts downward as the temperature cycles proceed with the maximum heating temperature -3°C , and hence the residual strain increases. However, with the maximum temperature -6°C , -10°C , or -30°C , such shifts are not observed for all cycles. Hence, deteriorations of concrete depend on the maximum heating temperature in the range between about -10°C and zero.

Figure 10 shows change of dynamic modulus of elasticity during the repetition of cooling and heating when various maximum temperatures are used. Full lines in Figure 10 indicated influences of the designed temperature cycles as well as those of the initial and final cycles between $+20^{\circ}\text{C}$ and -70°C . A dotted line named for reference indicates the latter, it is a strain behavior of one cycle from $+20^{\circ}\text{C}$ and -70°C . Hence, we can approximately obtain the influences of the designed temperature cycles by taking the differences between the corresponding full line and the reference; namely, the full line lower than the reference suggests that the corresponding designed maximum temperature makes some contributions on deterioration of concrete, and the full line close to the reference suggests that the corresponding designed temperature makes little contributions on deterioration. Hence, the degree of deterioration is almost the same as the reference, when the maximum heating temperature is -30°C , -10°C , or -6°C . and it becomes greater than the reference when heating temperature is -3°C and $+4^{\circ}\text{C}$. The result for loss in dynamic modulus of elasticity agrees well with that for residual strain studied in the above.

The above results may suggest that concrete is not deteriorated in some cases, even if it shows expansion during cooling. This is clearly seen from Figure 9(b); though concrete expands considerably from -20°C to -50°C on second cycle, the residual strain does not increase and the dynamic modulus of elasticity does not decrease, as the repetition of cooling and heating proceeds. The mechanism of this observation can be explained as follows: ice in pores is thawed from smaller pore as the temperature increases, and water is scarcely transportable due to the ice in larger pores which is not yet thawed till the temperature is up to -10°C . Therefore, it seems that deterioration can proceed if the temperature of concrete rises up till water in concrete is transportable and then water is frozen in other places during cooling. Hence, a non-linear thermal behavior of concrete only shows the phase transformation, does not indicate necessarily initiation of microcracks due to it.

From experiments for mortar [4],[10], the temperature at which mortar starts expansion during cooling or that at which mortar starts contraction during heating is almost the same, regardless of water cement ratio. Consequently, the transite temperature does not depend on the mix proportions of concrete, even though they change the porosities or pore distributions of concrete [9].

Therefore, it can be expected that the temperature ranges that influence deterioration of concrete may have little dependence on the mix proportions. The ranges identified in this study can be applicable to various concretes. However, the degree of deterioration is influenced by the pore distributions or porosities determined by the mix proportions, since the depression of freezing point is a function of pore size.

3.4 Strain behavior of constituent of concrete

Constituents of hardened concrete are pastes, sands, and coarse aggregates. Since global behaviors or properties of concrete are determined by those of the constituents, it is worth investigating how each constituent deteriorates under repetition of cooling and heating, in order to understand mechanism of concrete

deterioration. Under the same conditions, a saturated specimens of aggregate, paste, mortar, and concrete are subjected to freezing and thawing, and strain behaviors are monitored; water cement ratio of paste, mortar, and concrete are the same. Since material may not be homogeneous from the top to the bottom due to material segregation, we assumed strains measured on the center of a specimen as an average strain of the specimen; see Figure 2.

Figure 11 shows strain behaviors of each constituent during cooling at first cycle. A thermal expansion coefficient of the constituents and the residual strains after the fifth cycle are calculated. Table 2 shows the maximum value of expansions. From Figure 11 and Table 2, the maximum expansions and the residual strains after the fifth cycle were larger, in the order of paste, mortar, and concrete, and aggregate which was not expanded at all. Hence, strain behavior and deterioration of concrete are mainly due to cement paste.

Since the difference in thermal expansion coefficients of cement paste and aggregate is relatively large, there is great possibility of interfacial fracture between cement paste and an aggregate, which may contribute deterioration of concrete.

Aggregate used in this study is of good quality, high density, and low porosity, and its strain behavior is almost linear, and i.e. shows scarce residual strain, when it is subjected repetition of cooling and heating. Hence, there should be little contribution from aggregate on deterioration of concrete.

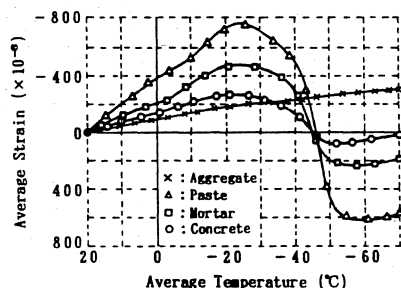

Fig.11 Relation between strain and temperature of concrete constituents

Table 2 Properties of concrete constituents

Type of concrete constituent	Coefficient of thermal expansion ($\times 10^{-6}/^{\circ}\text{C}$)		Maximum expansion ($\times 10^{-6}$)	Residual strain after the 5th cycle ($\times 10^{-6}$)
	-10°C	-45°C		
Aggregate	4.6	3.0	—	0
Paste	17.5	-122.9	1367	908
Mortar	13.0	-66.9	703	582
Concrete	6.9	-25.7	376	445

From the above results, it seems that deterioration of concrete is caused by the following two reasons: 1) deterioration of paste and 2) interfacial fracture between aggregate and paste. Hence, we can increase durability of concrete; by making durable cement paste of lower water cement ratio or lower moisture content, and AE agent [16].

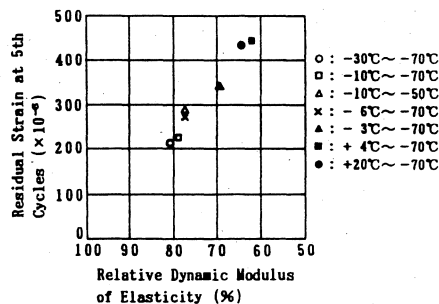

Fig.12 Correlation between residual strain and relative dynamic modulus of elasticity

3.5 Synthetical consideration

Figure 12 shows a relation between the relative dynamic modulus of elasticity and residual strain at fifth cycle for various concrete. It is seen that the residual strain and the relative dynamic modulus of elasticity are well correlated to each other [17],[18]. Consequently, the residual strain can be a good parameter for assessment of potential frost damage, which agrees with the result of MacInnis et al. [19].

Figure 13 shows a relation between the residual strain at fifth cycle and the minimum cooling temperature, and Figure 14 shows a relation between the relative dynamic modulus of elasticity and the minimum cooling temperature. It is seen that the degree of concrete deterioration is greatly changed, depending on the value of minimum cooling temperature lying between -20°C and -50°C . In particular, the range between -40°C and -50°C seems to have the greatest effects on deterioration.

Figure 15 shows a relation between the maximum heating temperature and the residual strain at fifth cycle, and Figure 16 shows a relation between the maximum heating temperature and the relative dynamic modulus of elasticity under

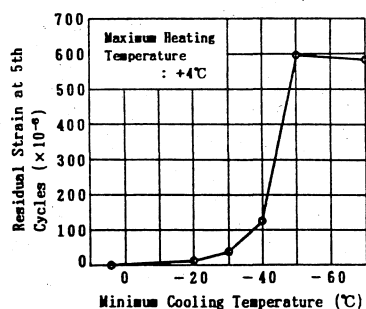

Fig.13 Relation between residual strain and minimum cooling temperature

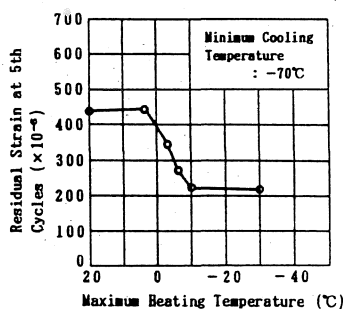

Fig.15 Relation between residual strain and maximum heating temperature

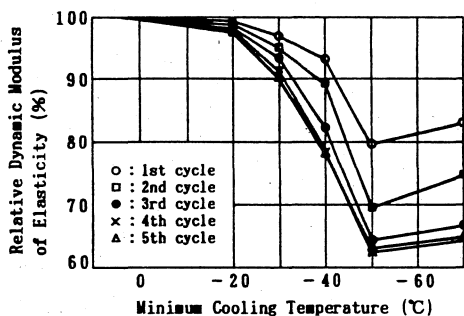

Fig.14 Relation between relative dynamic modulus of elasticity and minimum cooling temperature

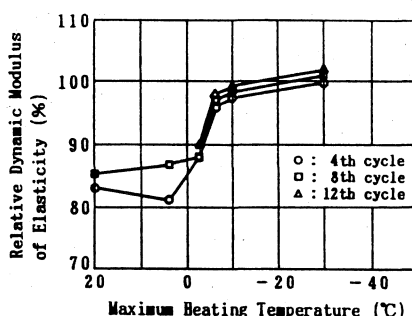
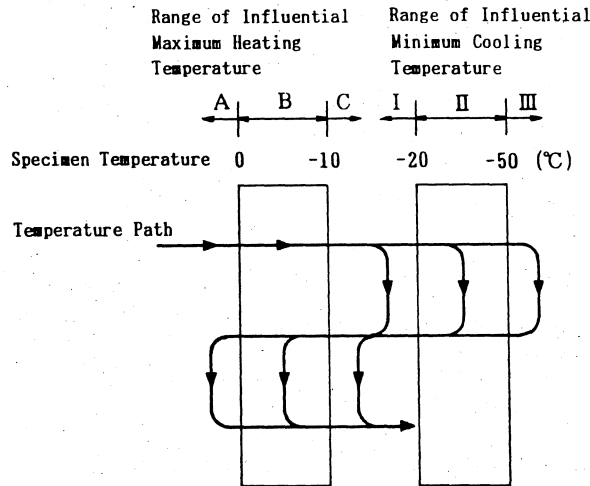

Fig.16 Relation between relative dynamic modulus of elasticity and maximum heating temperature



Degree of Concrete Deterioration

Range of Maximum Temperature \ Range of Minimum Temperature	I (over -20°C)	II (-20°C ~ -50°C)	III (below -50°C)
A (over 0°C)	○	△	×
B (0°C ~ -10°C)	○	△	△
C (below -10°C)	○	○	○

- : no deterioration
- △ : depend on the temperatures
- × : maximum deterioration

Fig.17 A model for estimating concrete deterioration

the designed cycles (shown as full line in Figure 3). It is seen that the maximum heating temperature lying between -10°C and 0°C has a considerable effects on deterioration.

Figure 17 is chart from which the degree of concrete deterioration is estimated, when the structure is subjected to repetition of cooling and heating. Based on the results obtained, we divide the minimum cooling temperature and the maximum heating temperature into three ranges, I, II, III for the minimum temperature or A, B, C for the maximum temperature.

The effects of the minimum cooling temperature on deterioration of concrete are summarized as follows: 1) if the temperature is above -20°C (Range I), concrete does not deteriorate; 2) if the temperature is between -20°C and -50°C (Range II), deterioration increases as the temperature decreases; and 3) if the temperature is below -50°C (Range III), deterioration is almost the same as the case of the minimum temperature -50°C . The effects of the maximum heating temperature are summarized as follows: 1) if the temperature is below -10°C (Range C), concrete does not deteriorate even the minimum cooling temperature is low enough; 2) if the temperature is between -10°C and 0°C (Range B), deterioration increases as the temperature increases; and 3) if the temperature

is above 0°C (Range A), deterioration is almost the same as the case of the maximum temperature 0°C .

Based on the above summaries, we can conclude that when the minimum cooling temperature or the maximum heating temperature is under Range I or C respectively, concrete suffers little deterioration; when the temperatures are under Range II and B, deterioration increases as the cooling temperature decreases or the heating temperature increases; but, when the temperatures are in Range III and A, concrete shows the greatest deterioration. However, Range B is very small, and the degree of deterioration changes significantly within Range B. Hence, from a practical point of view, it is better to estimate that deterioration occurs when the maximum heating temperature is above -10°C .

The above results suggest that no deterioration occurs in concrete, when it is not cooled down to -20°C or not heated up to -10°C in case of the cooling temperature was lower than -20°C . If these conditions are not satisfied, concrete can suffer deterioration when it is subjected to temperature cycle every time.

4. CONCLUSIONS

This study investigates how concrete deterioration is influenced by the cyclic temperature range, and what constituent of concrete has a contribution to deterioration, as concrete is exposed to low temperatures. Based on the experimental results, the following conclusions can be drawn:

(1) Degree of concrete deterioration depends on the minimum cooling temperature and the maximum heating temperature of cyclic temperature range.

a) When the minimum temperature is above -20°C , concrete suffers little deterioration; degree of deterioration increases as the minimum temperature decreases from -20°C to -50°C , and no further deterioration occurs even when the temperature goes down below -50°C .

b) When the maximum temperature is below -10°C , concrete does not deteriorate; degree of deterioration increases as the maximum temperature increases from -10°C to 0°C , and no further deterioration occurs even when the temperature goes up above 0°C .

Hence, in practical structures, if the temperature of concrete falls below -20°C and rises above 0°C , it is necessary to take a consideration to prevent deterioration due to each cyclic temperature ranges. Rational measures should be studied in future.

(2) Deterioration of concrete considerably depends on cement paste and interfacial fracture. Hence, cement paste should be made to be durable in order to produce a durable concrete, and interfacial fracture of the paste-aggregate should be paid sufficient attentions in studying deterioration.

(3) Loss of relative dynamic modulus of elasticity is almost proportional to residual strains. Both of them can be used as a good parameter for assessment of potential frost damage.

REFERENCES

- [1] T.Miura, "Properties of concrete at very low temperatures", Journal of Japan Concrete Institute, Vol.22, No.3, pp.21-28, 1984 (in Japanese)
- [2] F.S.Rostásy, G.Wiedemann, "Stress-strain behaviour of concrete at extremely low temperatures", Cement and Concrete Research, Vol.10, No. 4, pp.565-572,

1980

- [3] G.Tognon, "Behaviour of mortars and concretes in the temperature range from +20°C to -196°C", Proceedings of The Fifth International Symposium on the Chemistry of Cement, III-24, pp.229-249, Tokyo, 1968
- [4] FIP -state of art report- "Cryogenic behaviour of materials for prestressed concrete", Wexham Springs, pp.84, 1982
- [5] B.Zech, M.J.Setzer, "The dynamic modulus of hardened cement paste. Part 2: Ice formation, drying and pore size distribution", Materials and Structures, 22, pp.125-132, 1989
- [6] M.Elices, J.Planas, H.Corres, "Thermal deformation of loaded concrete at low temperatures, 2: Transverse deformation", Cement and Concrete Research, Vol.16, No.5, pp.741-748, 1986
- [7] T.Miura, D.H.Lee, "Deterioration of concrete subjected to repetition of cooling to -70°C", Review of the 42nd General Meeting, The Cement Association of Japan, pp.190-193, 1988
- [8] J.Planas, H.Corres, M.Elices, R.Chueca, "Thermal deformation of loaded concrete during thermal cycles from 20°C to -165°C", Cement and Concrete Research, Vol.14, No.5, pp.639-644, 1984
- [9] W.Czernin, "Zementchmie für bauingenieure", Bauverlag Inc., Wiesbaden, Germany, 1964
- [10] F.S.Rostásy, U.Schneider, G.Wiedemann, "Behaviour of mortar and concrete at extremely low temperatures", Cement and Concrete Research, Vol.9, No.3, pp.365-376, 1979
- [11] W.A.Cordon, "Freezing and thawing of concrete - mechanisms and control", ACI Monograph, No.3, pp.99, 1966
- [12] T.C.Powers, "A working hypothesis for further studies of frost resistance of concrete", Journal of ACI, Vol.16, No.4, pp.245-272, 1945
- [13] Y.Goto, T.Miura, "Deterioration of concrete subjected to repetitions of very low temperatures", Transactions of the Japan Concrete Institute, pp.183-190, 1979
- [14] Y.Koh, E.Kamada, "The behavior of concrete subjected to freezing and thawing as a reference for frost resistivity of concrete", Proceedings of The Fifth International Symposium on the Chemistry of Cement, III-99, pp.300-315, Tokyo, 1968
- [15] N.Stockhausen, H.Dorner, B.Zech, M.J.Setzer, "Untersuchung von gefriervorgängen in zementstein mit hilfe der DTA", Cement and Concrete Research, Vol.9, No.6, pp.783-794, 1979
- [16] T.Miura, M.Fujiwara, "Deterioration of concrete cooled to very low temperatures", JCI of Conference, pp.57-60, 1982 (in Japanese)
- [17] D.H.Lee, T.Miura, "The relation between strain and deterioration of the concrete subjected to repetition of very low temperatures", Abstracts, JSCE 43rd Annual Research Presentation Meeting, pp.180-181, 1988 (in Japanese)
- [18] D.H.Lee, T.Miura, K.Kodama, "Effect of cyclic temperature range on deterioration of concrete", Abstracts, JSCE 44th Annual Research Presentation Meeting, pp.368-369, 1989 (in Japanese)
- [19] C.MacInnis, J.D.Whiting, "The frost resistance of concrete subjected to a deicing agent", Cement and Concrete Research, Vol.9, No.3, pp.325-336, 1979

**STUDIES OF THE SCALING, THE WATER UPTAKE AND THE
DILATION OF SPECIMENS EXPOSED TO FREEZING AND THAWING
IN NaCl-SOLUTION**

Göran Fagerlund

Division of Building Materials. Lund Institute of Technology
Lund, Sweden

STUDIES OF THE SCALING, THE WATER UPTAKE AND THE DILATION OF MORTAR SPECIMENS EXPOSED TO FREEZING AND THAWING IN NaCl-SOLUTIONS

Report presented to RILEM Technical committee TC 117 at the meeting in Lund June 17-18, 1991.

Göran Fagerlund
Div of building materials
Lund Institute of Technology
Lund, Sweden.

Preface

The work that is presented in this report is part of a larger study that was performed during the years 1973-1974. The results have not been published before.

1. Background- aim

The aim of the study was to investigate if the so called critical degree of saturation concept could be used also when freeze/thaw takes place in the presence of de-icing salts. Therefore, a rather large study was made in which the critical degree of saturation was determined experimentally for concrete specimens that had been pre-conditioned to different degrees of saturation in NaCl-solutions of different concentrations (0; 2,5; 5; 10%). Besides, the capillary water uptake as function of time was determined for the same concretes and the same salt concentrations. The results were negative in that sense that very little effects of the salt concentrations could be discerned; the frost resistance defined as the difference between the critical and the capillary degree of saturation (see /1/) was almost the same irrespectively of the salt concentration. The reason for this astonishing result is probably that the salt did not have time to penetrate the full volume of the specimen before the freeze/thaw test started. This test is made with sealed specimens which means that no salt water absorption could occur during the test itself. Thus, all specimens were tested with almost 0% NaCl-concentration in the pore system despite the fact that the concentration of the solution that was used for "filling" the specimens before the test was different. Some of those results have been published in an internal report /2/. Most of the results are, however, unpublished.

Some additional studies were made in which the scaling and the salt water absorption were followed during freeze/thaw tests of unsealed specimens of OPC-mortars. In another test series the expansion during freezing of OPC-mortars was studied. The mortars were pre-stored for such a long time in NaCl-solutions of different concentrations that the pore-water in the whole specimen was in equilibrium with the outer salt concentration. Some results of these studies are presented in this report.

2. Mortars - specimens

9 different cement mortars were tested; see Table 1. The nominal w/c-ratios were 0,4, 0,6 and 0,7. The nominal air contents were 3%, 6% and 8%. The 3% mortars were non-airentrained. The real w/c-ratios and air contents are listed in APPENDIX 1. The air contents deviate rather much from the desired ones, especially for the 0,6-mortars.

The cement was of type OPC with low alkali content (0,2%) and sulfate resistance ($C_3A=5\%$). The air-entraining agent was of type Darex AEA.

All specimens were table vibrated. The specimen size and the storage of the specimens before the test are described below; they are different for each type of test.

Table 1: Mortars; nominal w/c-ratios and air contents. Designations of the mortars.

Nominal air content %	w/c-ratio		
	0,40	0,60	0,70
3	11	12	13
6	21	22	23
8	31	32	33

3. Test 1. Scaling and salt water uptake during freeze/thaw.

Aim:

The aim of test 1 was to investigate the effect of the outer salt concentration on the scaling and absorption during freeze/thaw. Also the effect of the pre-conditioning of the specimens -air-dried or water-stored- on those properties was investigated.

Test procedure.

The pre-conditioned mortar cylinders ($\phi 50 \times 100$ mm) were placed in cylindrical plastic beakers ($\phi 82 \times 145$ mm). About 0,53 litres of solution was poured in the beaker so that the specimen was completely covered. The beaker was covered with a lid in order to prevent evaporation. Each specimen was exposed to 12 freeze/thaw cycles of the shape shown in Fig 1.

After the terminated freeze/thaw test, the fragments scaled off from the specimens were dried and weighed (ΔQ_d). The specimen was weighed before the test (Q_o). The "torso" that remained after the test was weighed (Q_1), then dried at $+105^\circ\text{C}$ and weighed (Q_d). It was resaturated by complete vacuum and weighed in water (Q_w) and in air (Q_a). Thus, the porosity P_o , the degree of saturation before (S_o) and after the test (S_1) could be evaluated:

$$P_o = \frac{Q_a - Q_d}{Q_a - Q_w} \quad (1)$$

$$S_o = \frac{Q_o - (Q_d + \Delta Q_d)}{Q_a + Q_d(1 + P_o / \rho_f(1 - P_o)) - (Q_d + \Delta Q_d)} \quad (2)$$

$$S_1 = \frac{Q_1 - Q_d}{Q_a - Q_d} \quad (3)$$

ρ_f is the density of the cement mortar without pores.

It is assumed that all weights are in grammes and that no salt has been deposited in the pores. This is a reasonable assumption since the salt water storage is very short (12 days). The S_o -values are almost the same for all specimens of the same type pre-treated in the same manner. One specimen of each mortar type was tested for each pre-conditioning and each salt concentration.

Pre-conditioning

Before the test the specimens were pre-conditioned in two different ways:

- * Method 1: Water-cured for 6 weeks followed by air-drying for 2 weeks.
- * Method 2: Water-cured for 6 weeks followed by air-drying for 1 week and water-storage for 2 weeks.

Salt concentrations

4 concentrations of NaCl were used; 0; 2,5; 5; 10%. The density (d) of the solution is a function of its concentration (c%). The following relation was determined by aerometer:

$$d = 0,9978 + 0,00658 c \quad (4)$$

Results

The scaling ΔQ_d and the degree of saturation after terminated freeze/thaw, S_1 , as function of the outer salt concentration are shown in Fig 2-4. In Fig 5-6 the scaling is plotted versus the w/c-ratio. Photos of the tested specimens are shown in APPENDIX 2.

It is quite clear that freeze/thaw in pure water does always produce much less scaling than freeze/thaw in salt solutions. It is also clear that 2,5% does normally produce the most severe scaling when the specimens are air-dried before the test starts; 10% solution is in this case not much more severe than pure water, see Fig 5. When the specimens are water-stored before the test starts it seems as if 5% and 10% are the most severe concentrations, see Fig 6. The reason might be that salt in this case is entering the specimen by slow diffusion whilst it enters by a more rapid combination of diffusion and convection in the case of an air-dried specimen. Hence, it might very well be that the pessimum concentration inside the specimen is the same in both cases.

The (salt) water absorption in the specimens during the freeze/thaw cycles is normally lower when the the specimens are frozen in pure water. One reason for this might be that the total suction time is lower in this case since all water surrounding the specimen is transformed into ice during the frost periods. An additional explanation might be that the permeability of the remaining specimen "torso" has increased due to the more severe frost damage when salt solutions are used. If this is true, the observed increase in the water uptake is just a measure of the increased internal damage. It must be observed, however, that the degree of saturation is measured on the torso remaining and not on the outer part of the specimen that has scaled off. A high degree of saturation of the torso is, however, an indication of a high moisture content also in the destroyed part of the specimen.

The salt scaling is diminished when the air content is increased. However, when the air content becomes too high (15% in mortar 32) there is a clear tendency of an increased scaling. The scaling also increases with increased w/c-ratio; for w/c=0,70 a very high air content is needed in order to make the mortar durable. For w/c=0,40 even the non-aientrained mortar behaved fairly well although the scaling was still more reduced in the airetrained mortars.

4. Test 2. Isothermal (salt) water uptake.

Aim

The aim of test 2 was to investigate the effect of the outer salt concentration on the absorption of solution in air-dried specimens that are fully immersed in the solution.

Test procedure

The pre-conditioned mortar cylinders ($\varnothing 50 \times 100$ mm) were placed in the plastic beakers described above. Pure water or NaCl-solution was poured in the beaker so that the specimen was covered. The total amount of solution was about 0,5 litres. The beakers were stored at room temperature for 13 days whereupon the specimens were weighed (Q_1), dried at $+105^\circ\text{C}$ and weighed (Q_d), resaturated by vacuum and weighed in air (Q_a) and in water (Q_w). The specimens were also weighed before the test started (Q_0). The degrees of saturation before (S_0) and after the test (S_1) are calculated by:

$$S_0 = \frac{Q_0 - Q_d}{Q_a - Q_d} \quad (5)$$

$$S_1 = \frac{Q_1 - Q_d}{Q_a - Q_d} \quad (3)$$

where Q is in gram.

The density of the salt solution before and after the test was determined by aerometer. The solution sucked into the specimens was, however, so small in comparison with the total amount of solution that the measurements became too insensitive in order to reveal any concentration changes.

2 specimens of each mortar was used for each concentration.

Pre-conditioning

All mortars were preconditioned according to method 1; i.e. they were water-cured for 6 weeks followed by air-drying in laboratory air for 2 weeks.

Salt concentrations

The concentrations 0; 2,5; 5; 10% were used.

Results

The degree of saturation after terminated absorption test is plotted in Fig 7-9. For $w/c=0,40$ (Fig 7) it seems as if a higher salt concentration gives somewhat higher degrees of saturation when the air content is low but lower degrees of saturation when the air content is high. The same trend, but less pronounced, can be found even for the other w/c -ratios. This means that it should be more difficult to water-fill the air pore system when salt solutions are used. There is no simple explanation for this observation.

In Fig 10-12 are plotted the differences between the degrees of saturation reached during 12 days of freezing and thawing and the degrees of saturation reached during 13 days of isothermal absorption. In almost all cases does the freeze/thaw force more (salt) water into the specimen. Besides, this extra (salt) water absorption is in most cases much higher when freezing takes place in salt water. It is not so easy to find an explanation for this behaviour. One might just as well have expected a drying out of the previously water-stored specimens due to the fact that the vapour pressure of the outer solution is lower than the vapour pressure of bulk water in the specimen. Such a drying out has been observed for mortar specimens stored in CaCl_2 -solutions /3/.

Possibly, the extra water absorption during freeze/thaw depends on the cyclic temperature variation. Or it might depend on cracks formed during the freeze/thaw action. Such cracks might open the structure so that air that is enclosed in air pores can be replaced by salt water.

5. Test 3. Dilation during freezing.

Aim

The aim of test 3 was to investigate the effect of the inner salt concentration and the effect of the degree of salt water saturation on the expansion of the specimen during freezing.

Test procedure

The pre-conditioned specimen (30·30·120 mm) which is unsealed is placed in the combined calorimeter-extensometer shown in Fig 13. The simultaneous ice formation and length changes can be measured. Only the length changes were measured in the actual tests. The freezing cycle is shown in Fig 14. The temperature was measured in each specimen by a thermocouple in the centre of the specimen. The specimen was weighed before (Q_0) and after the test (Q_1). Very little water was lost during the test. Then the specimen was dried at $+105^{\circ}\text{C}$ and weighed (Q_d). It was resaturated by vacuum and weighed in water (Q_w) and in air (Q_a). The degree of saturation could be calculated by eq (3) and (5).

Mortars tested

All 9 mortars were tested but in this report there are only shown results for two mortars (12 and 32 with a w/c-ratio of 0,60 and with low and high air content).

Pre-conditioning

The specimens were water-cured for 3 weeks followed by air-drying for 3 weeks. Then, each specimen was put in a vacuum-chamber which was evacuated to a certain residual pressure which was maintained for 24 hours. Salt solution of a given concentration was let into the chamber so that the specimen was covered. The vacuum pump was shut and the specimen was allowed to stay in salt water of the same concentration for 3 months. This long time of storage together with the forced absorption during the first time made the pore water come to equilibrium with the outer salt solution. This is confirmed by observations of the initial freezing points. They correspond well with the freezing points which are expected in bulk solution of the same concentration; see Fig 15.

By using different residual pressures different degrees of salt water saturation are reached. The following residual pressures were used:

760 torr (no vacuum);	gives S_1
150 torr	; gives S_2
50 torr	; gives S_3
2 torr	; gives S_4

Salt concentrations

The concentrations 0; 2,5; 5; 10% were used.

Results

The results are shown in Fig 16 and 17. In Fig 18 the total dilation at -25°C is plotted versus the salt concentration for different degrees of saturation.

The following conclusions can be drawn:

- * When the degree of saturation is low no or very little expansion occurs for all salt concentrations.
- * When the degree of saturation is high the largest expansion occurs at the concentration 2,5%. 5% and 10% is not much more severe than pure water. Unfortunately, specimens with medium high degrees of saturation are missing.

Therefore, it seems as if a 2,5% NaCl-solution inside the specimen creates larger destructive forces than other concentrations. One imaginable explanation is that the salt creates an osmotic pressure due to differences in salt concentration between water in pores containing ice bodies and pores with unfrozen solution. On the other hand, when the salt concentration is high the freezable water decreases. The net effect could be that the maximum stresses occur at a pessimum concentration which might be of the order of size of 2 to 3%.

6. Conclusions

The results can be summarized as follows:

1. The most severe salt scaling of specimens that are freeze/thaw-tested in NaCl-solution occurs at a certain pessimum concentration of this outer solution. The pessimum concentration is about 2,5% for specimens that are air-dried when the test starts but 5 or 10% when the specimens are water stored before the test.

2. The (salt) water uptake during freeze/thaw is higher than the uptake during isothermal capillary suction.
3. The absorption is higher when freeze/thaw takes place in salt solution than when it takes place in pure water.
4. The salt scaling is diminished when the air content is increased or the w/c-ratio decreased. For w/c=0,70 very high air contents are required.
5. The internal freeze-stresses increase with increasing degree of saturation of salt water.
6. At constant degree of salt water saturation the pessimum concentration of pore water seems to be about 2,5%.

References

- /1/ G. Fagerlund: The critical degree of saturation method of assessing the freeze/thaw resistance of concrete. Materials and Structures Vol 10, No 58, 1977.
- /2/ G. Fagerlund: Frost resistance of concrete flag stones. Div. of building materials, Lund Institute of Technology, Internal report March 1974.
- /3/ O. Petersson: The chemical effects on cement mortars of solutions of calcium magnesium acetate and other deicing salts. Div. of building materials, Lund Institute of Technology, Report TVBM-3045, 1991.

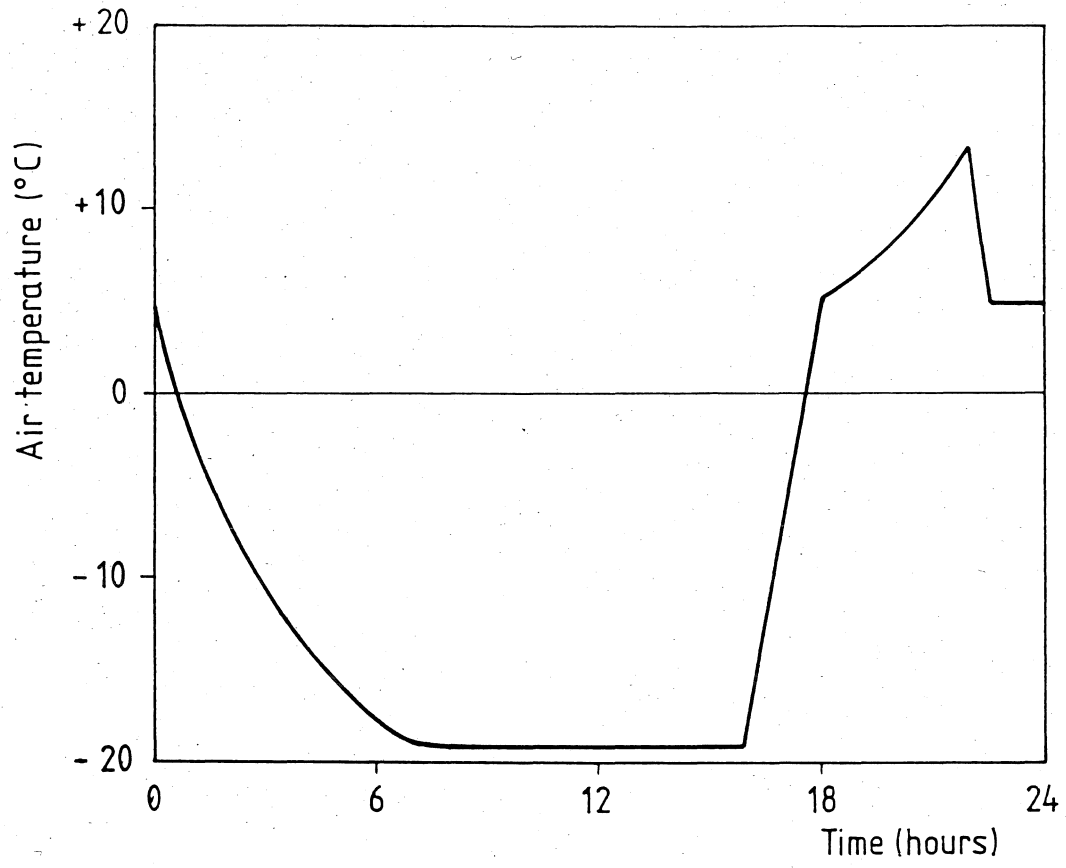
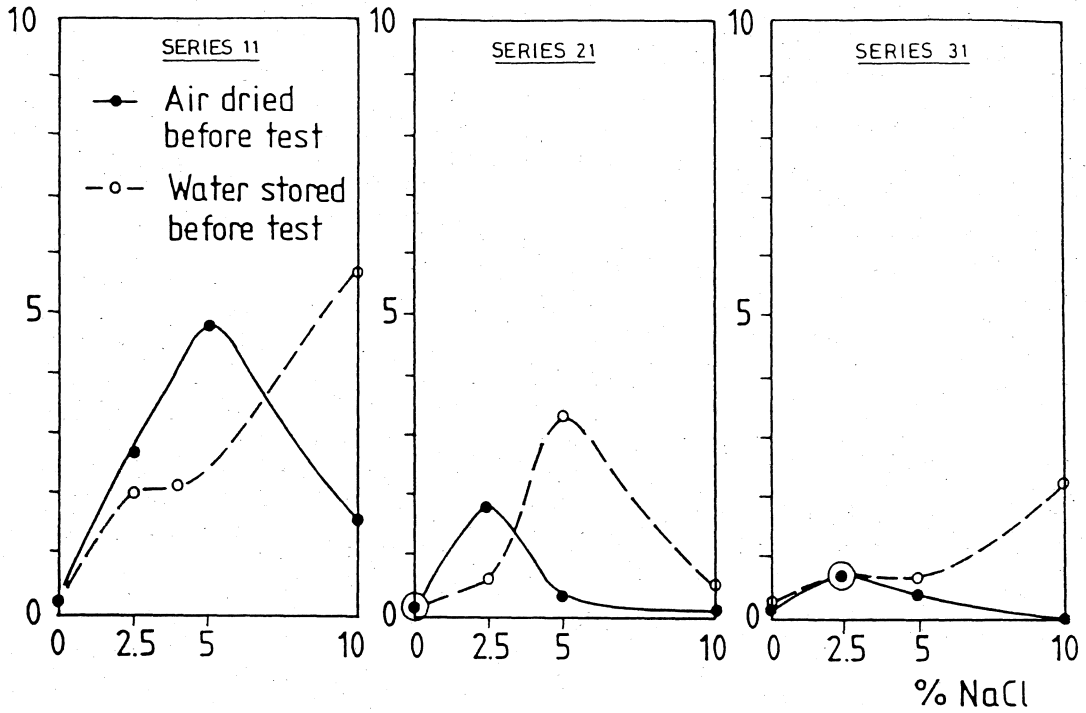

Fig 1: Salt scaling test; the freeze/thaw cycle.

Weight loss after 12 freeze-thaw cycles (g)



Degree of saturation after 12 freeze-thaw cycles

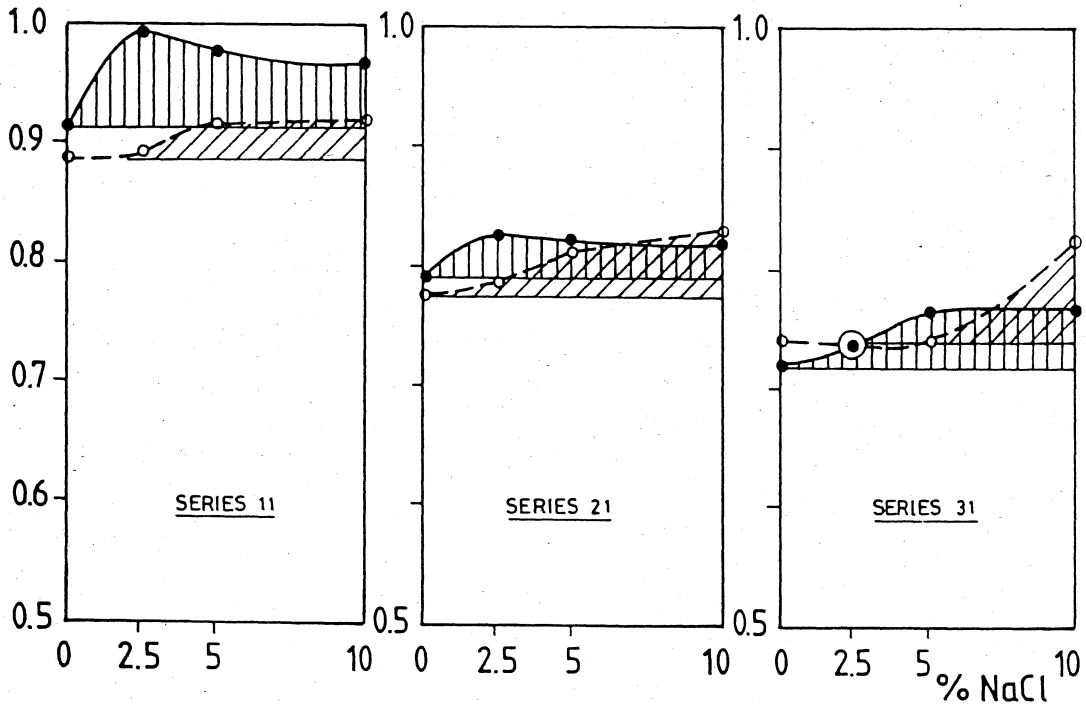

Fig 2: Salt scaling and degree of saturation after 12 cycles of freeze/thaw. Mortars with w/c-ratio 0,40.

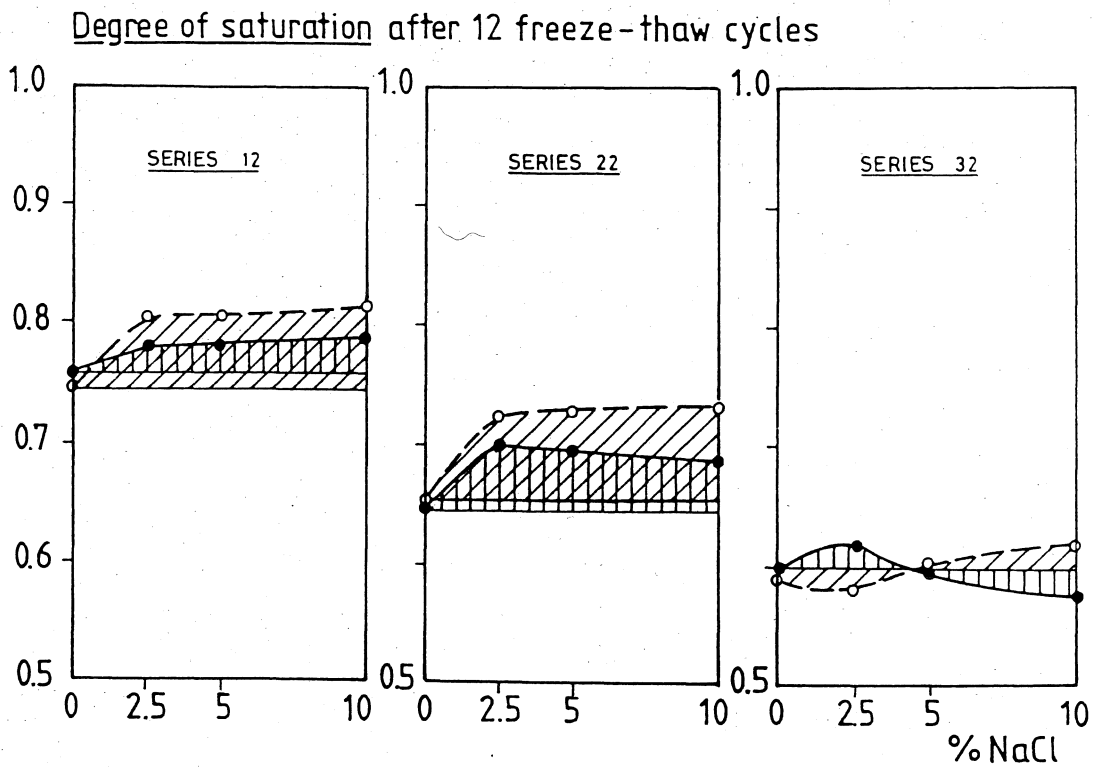
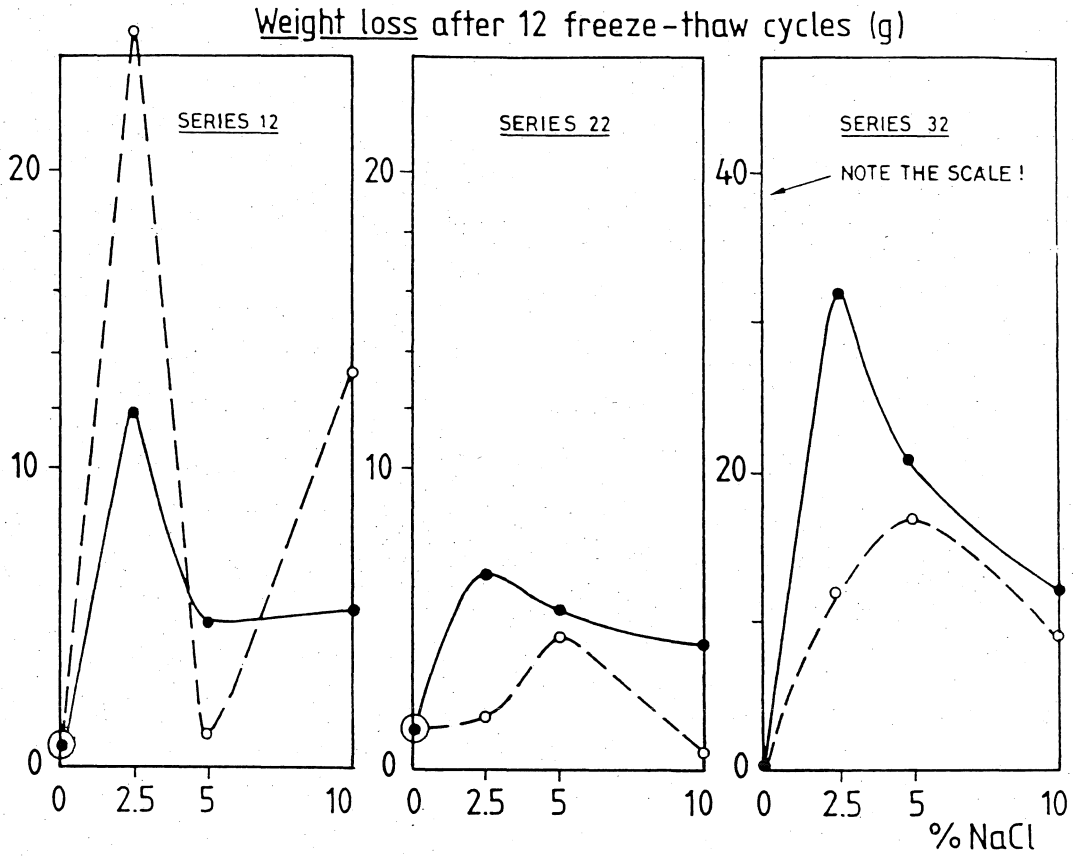

Fig 3: Salt scaling and degree of saturation after 12 cycles of freeze/thaw. Mortars with w/c-ratio 0,60.

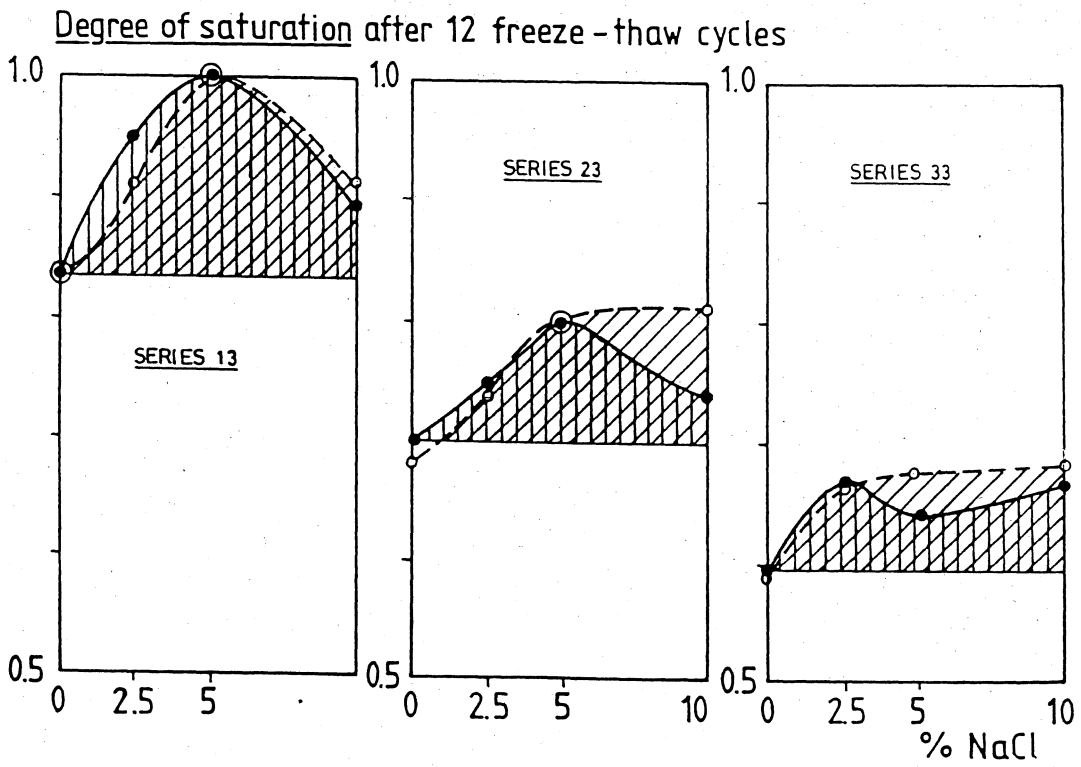
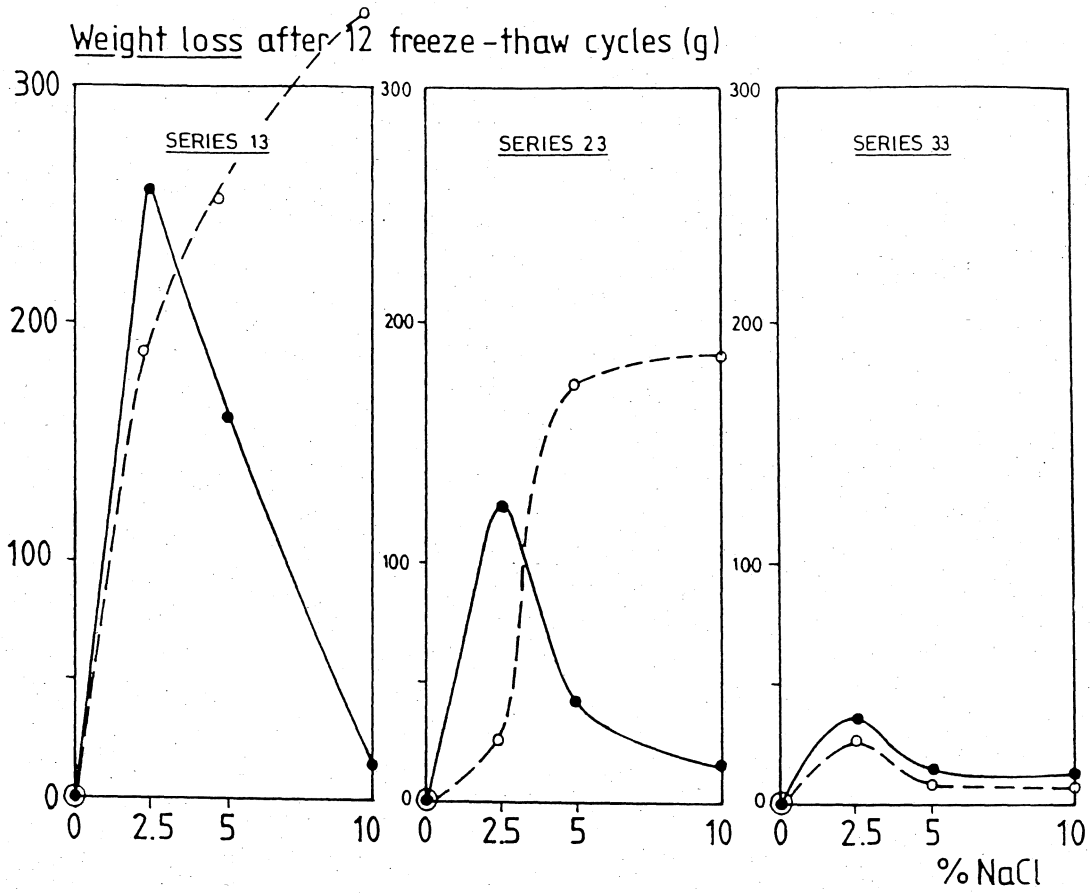

Fig 4: Salt scaling and degree of saturation after 12 cycles of freeze/thaw. Mortars with w/c-ratio 0,70.

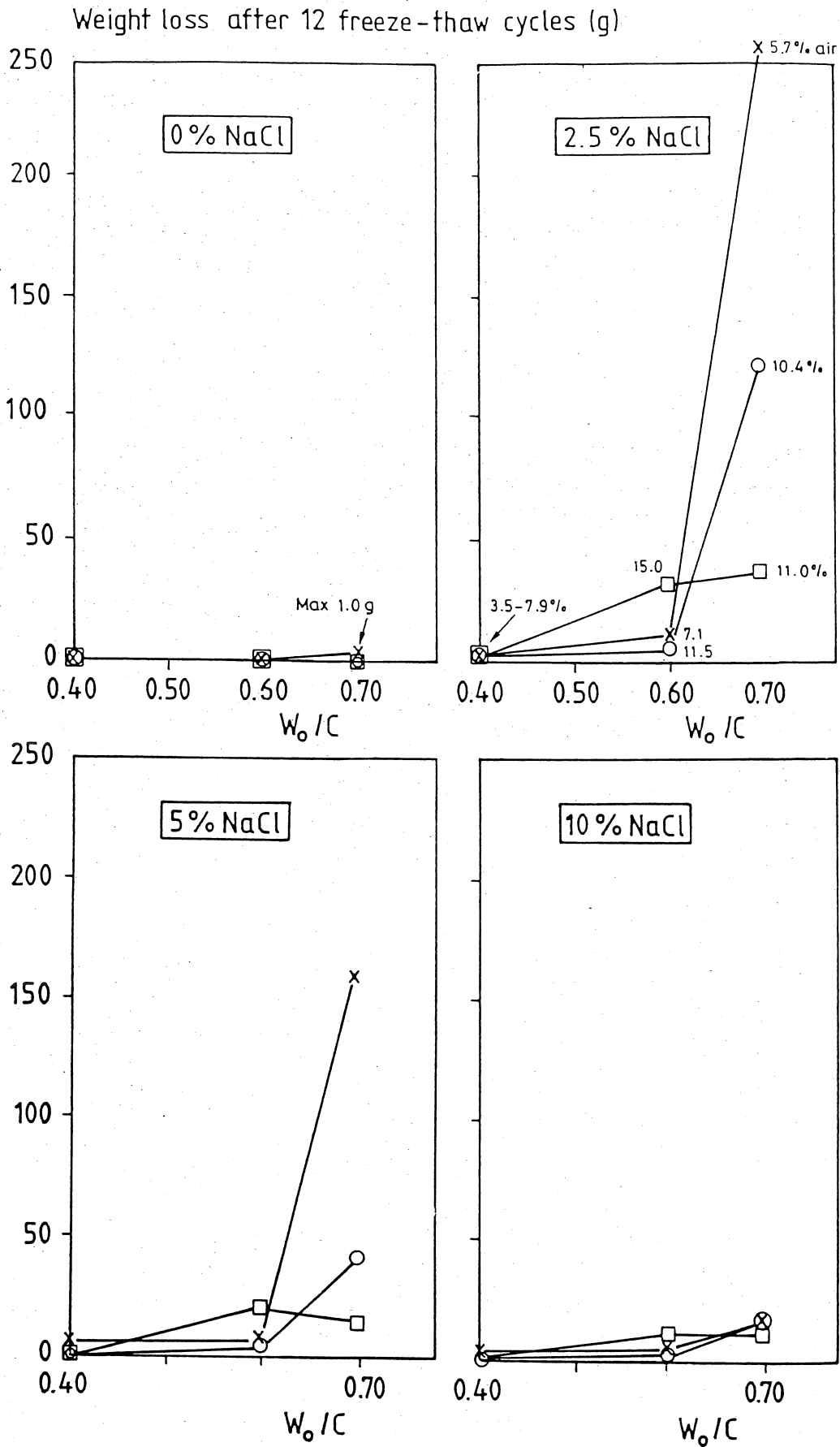

Fig 5: The total weight loss after 12 cycles of freeze/thaw of mortars that were pre-conditioned according to method 1; 6 weeks in water + 2 weeks in air.

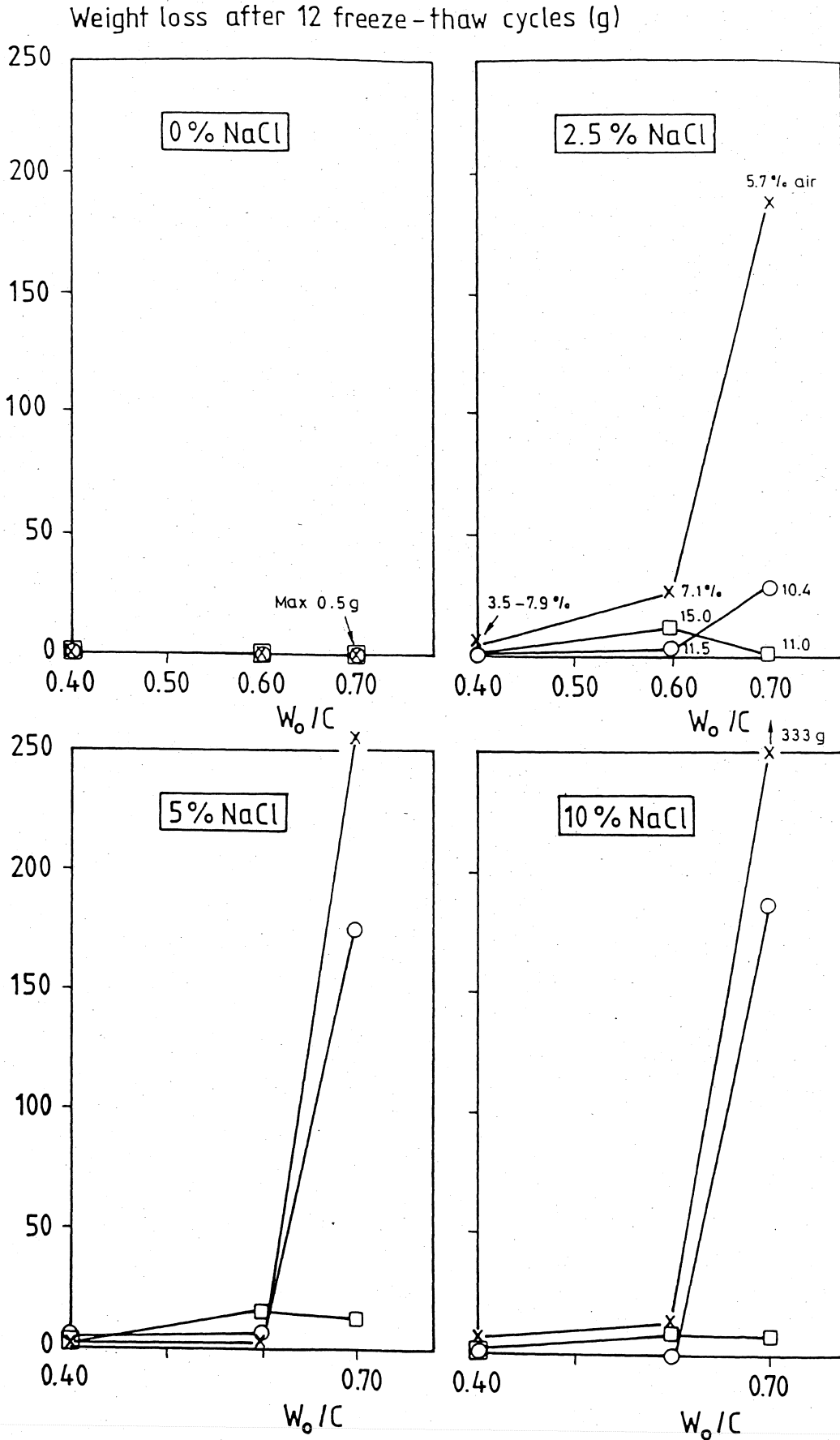

Fig 6: The total weight loss after 12 cycles of freeze/thaw of mortars that were pre-conditioned according to method 2; 6 weeks in water + 1 week in air + 2 weeks in water.

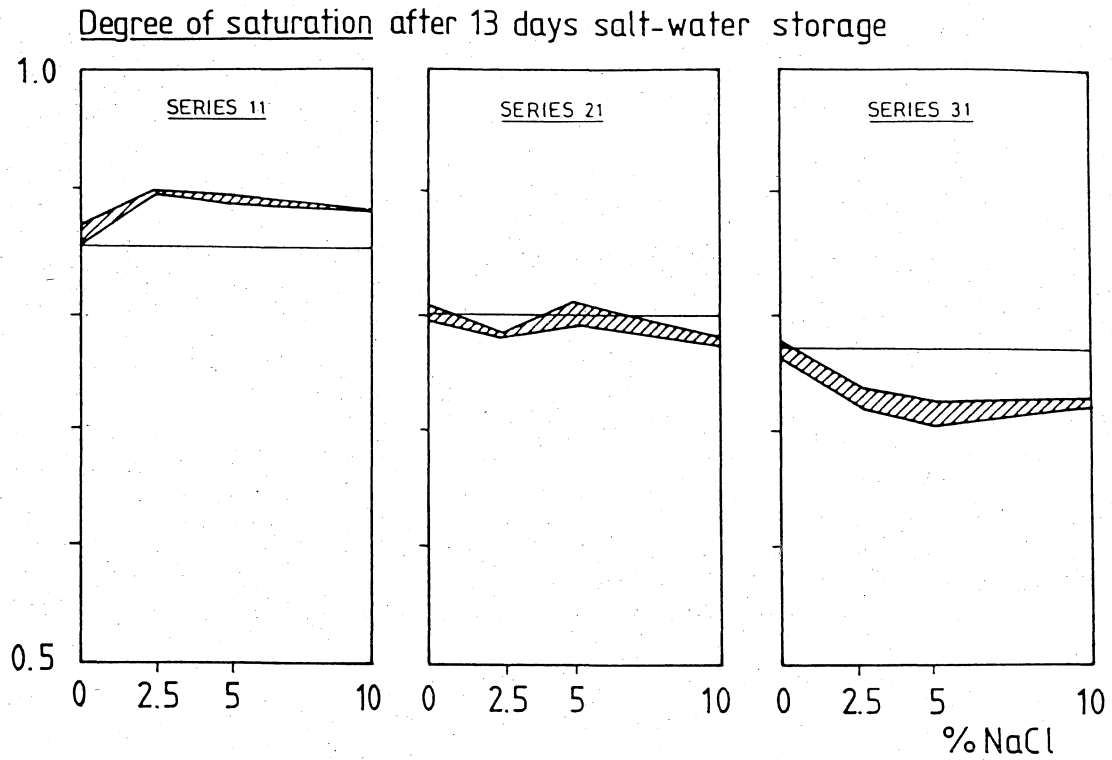

Fig 7: The degree of saturation after 13 days of isothermal absorption of immersed specimens. Mortars with w/c-ratio 0,40.

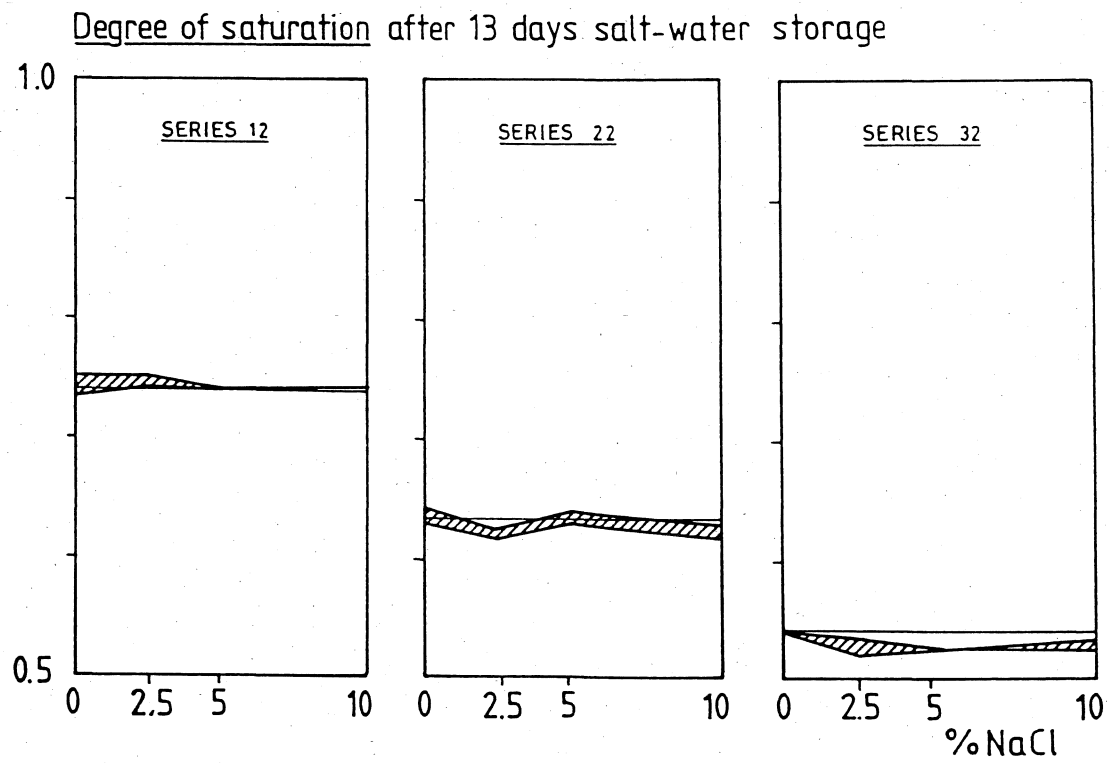

Fig 8: The degree of saturation after 13 days of isothermal absorption of immersed specimens. Mortars with w/c-ratio 0,60.

Degree of saturation after 13 days salt-water storage

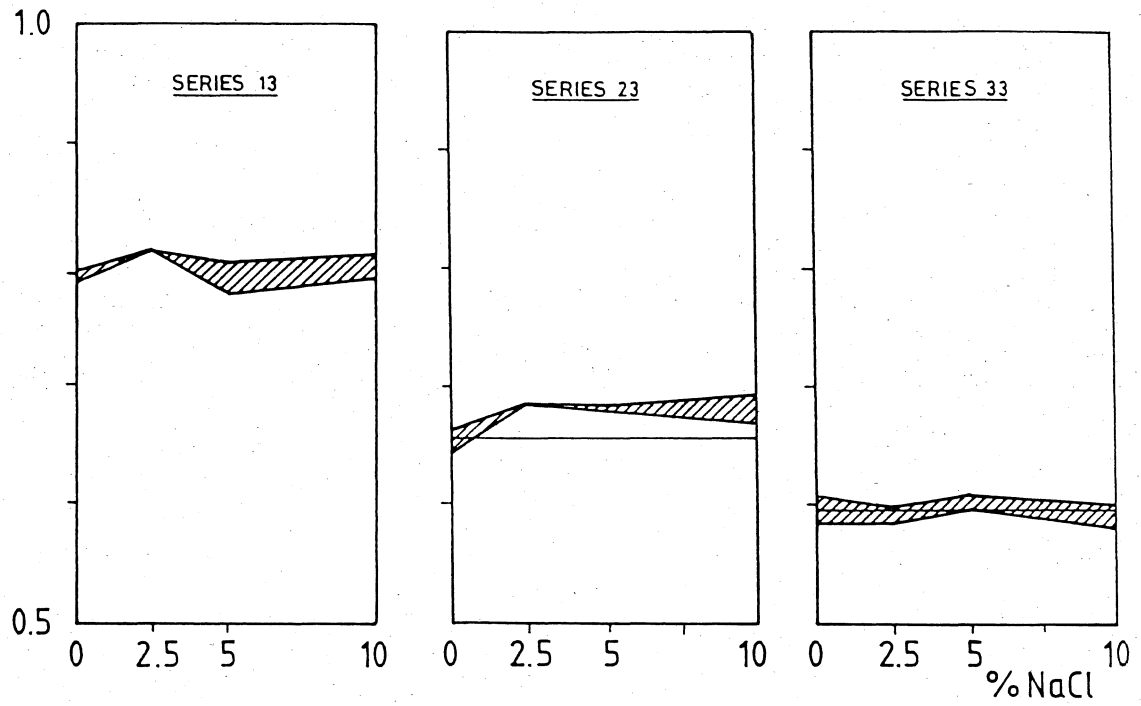

Fig 9 The degree of saturation after 13 days of isothermal absorption of immersed specimens. Mortars with w/c-ratio 0,70.

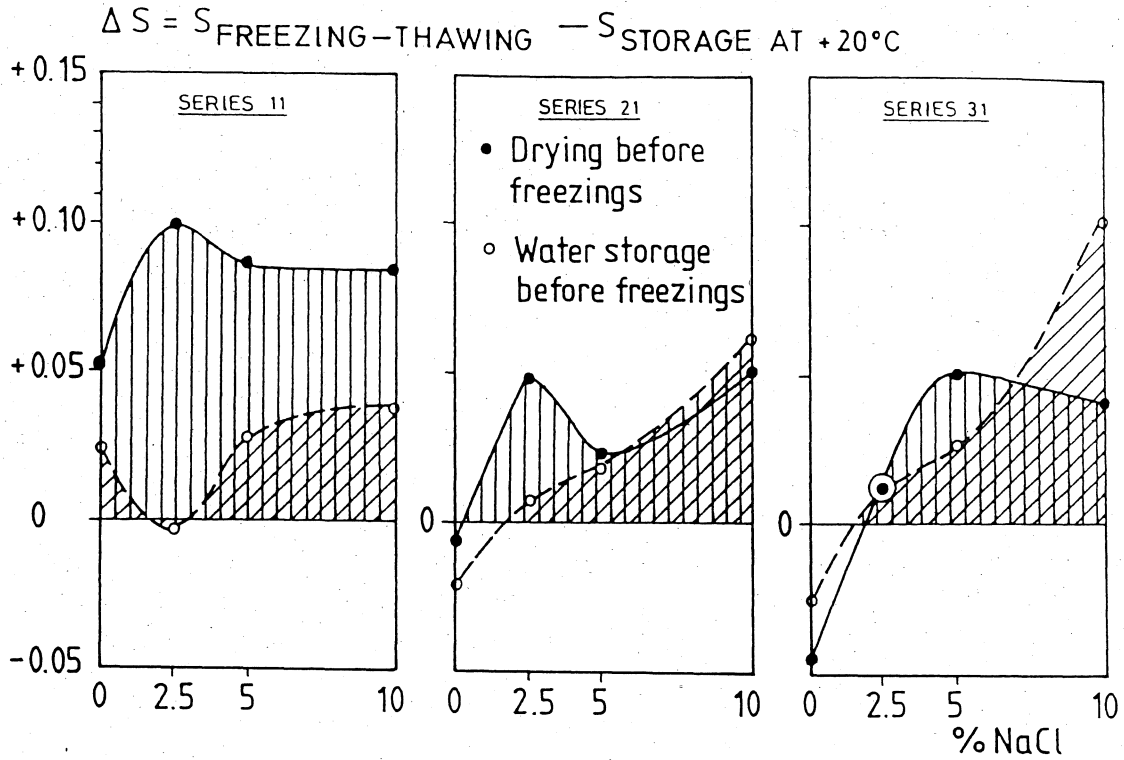

Fig 10: The difference in degree of saturation reached after 12 cycles of freeze/thaw and after 13 days of isothermal absorption. Mortars with w/c-ratio 0,40.

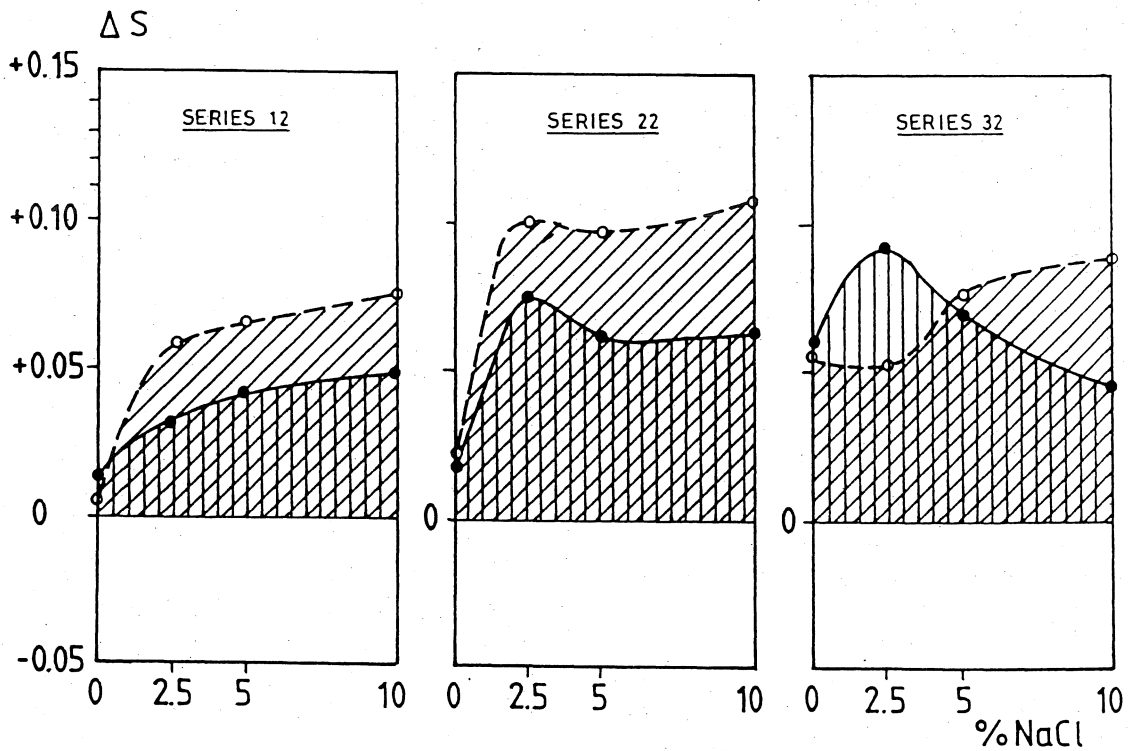

Fig 11: The difference in degree of saturation reached after 12 cycles of freeze/thaw and after 13 days of isothermal absorption. Mortars with w/c-ratio 0,60.

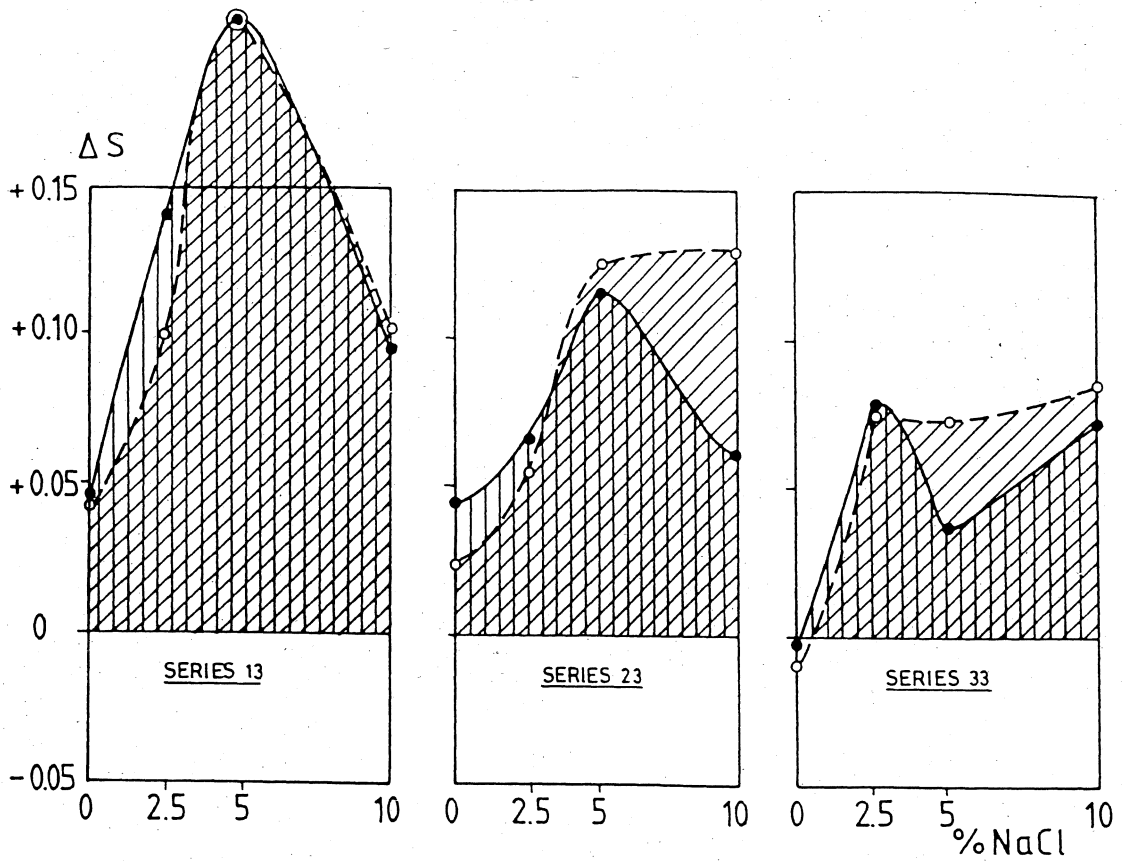

Fig 12: The difference in degree of saturation reached after 12 cycles of freeze/thaw and after 13 days of isothermal absorption. Mortars with w/c-ratio 0,70.

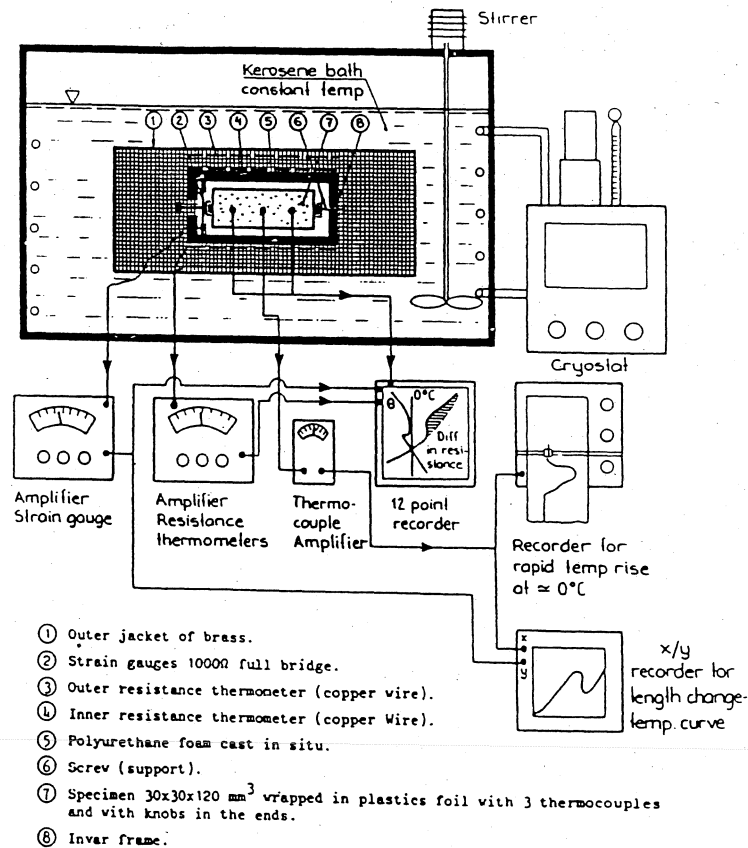

Fig 13: Combined calorimeter/extensometer.

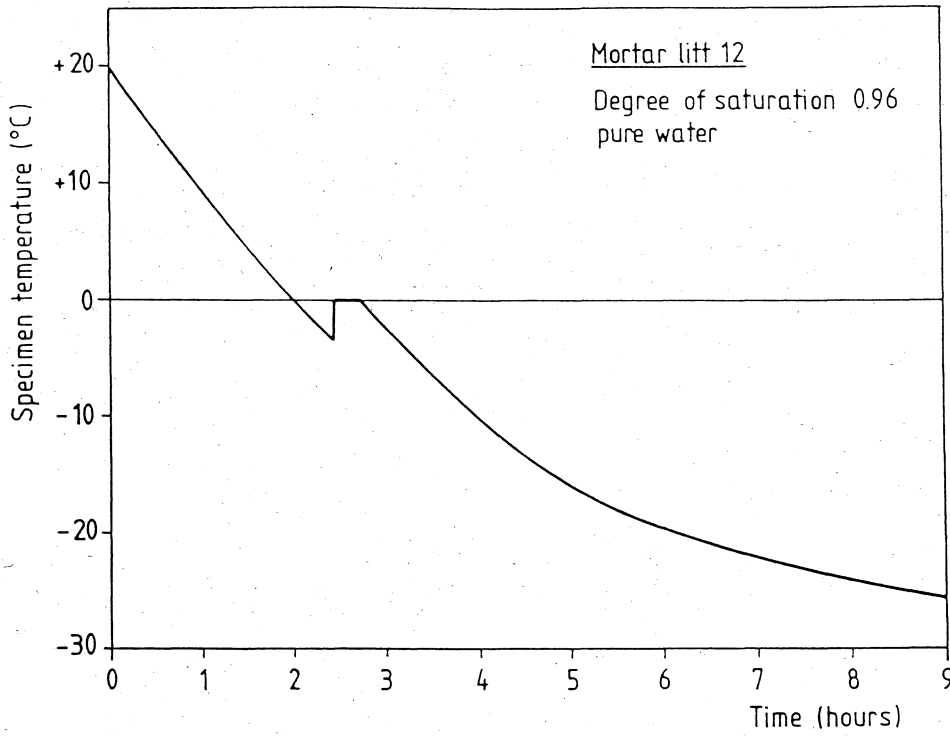

Fig 14: Dilatometer test; the freeze/thaw cycle.

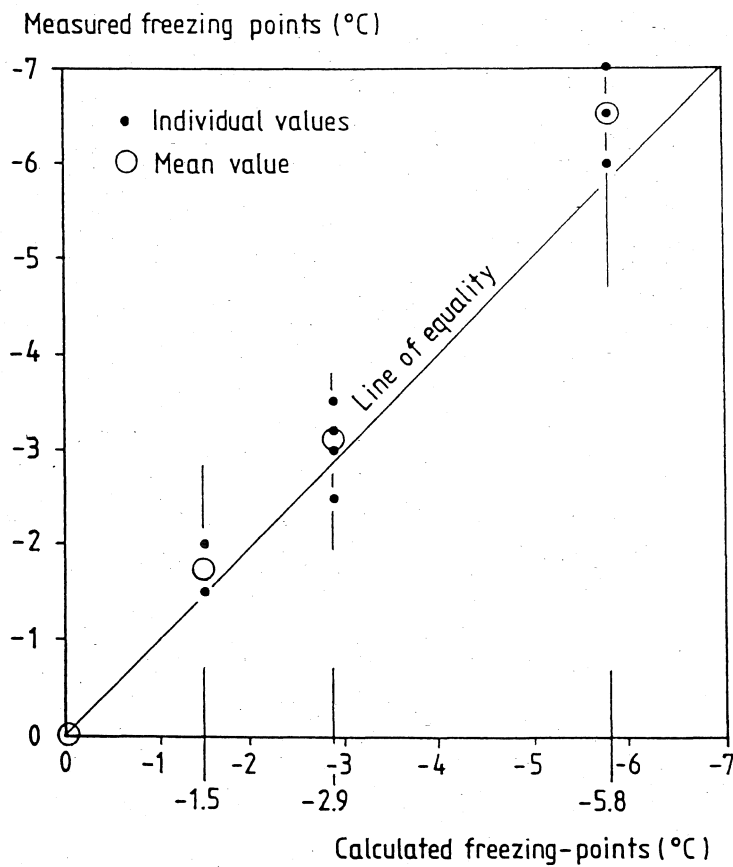

Fig 15: Measured initial freezing points of the salt water stored mortars and the theoretical freezing point of the bulk solution.

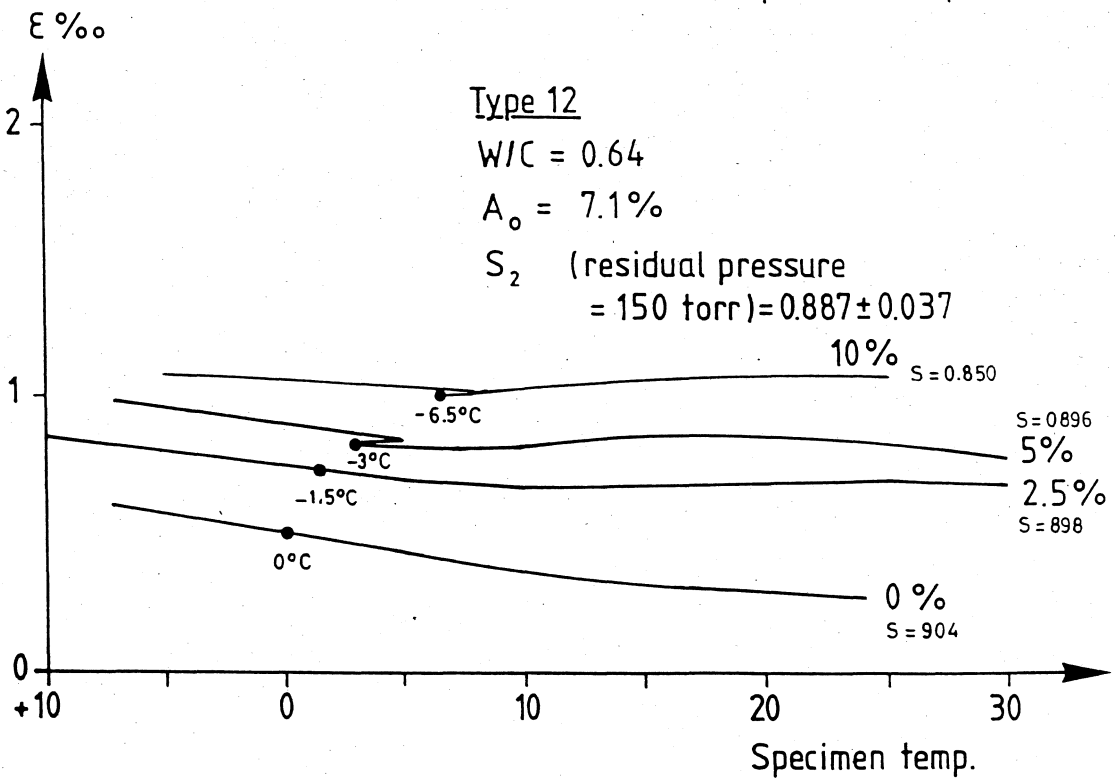
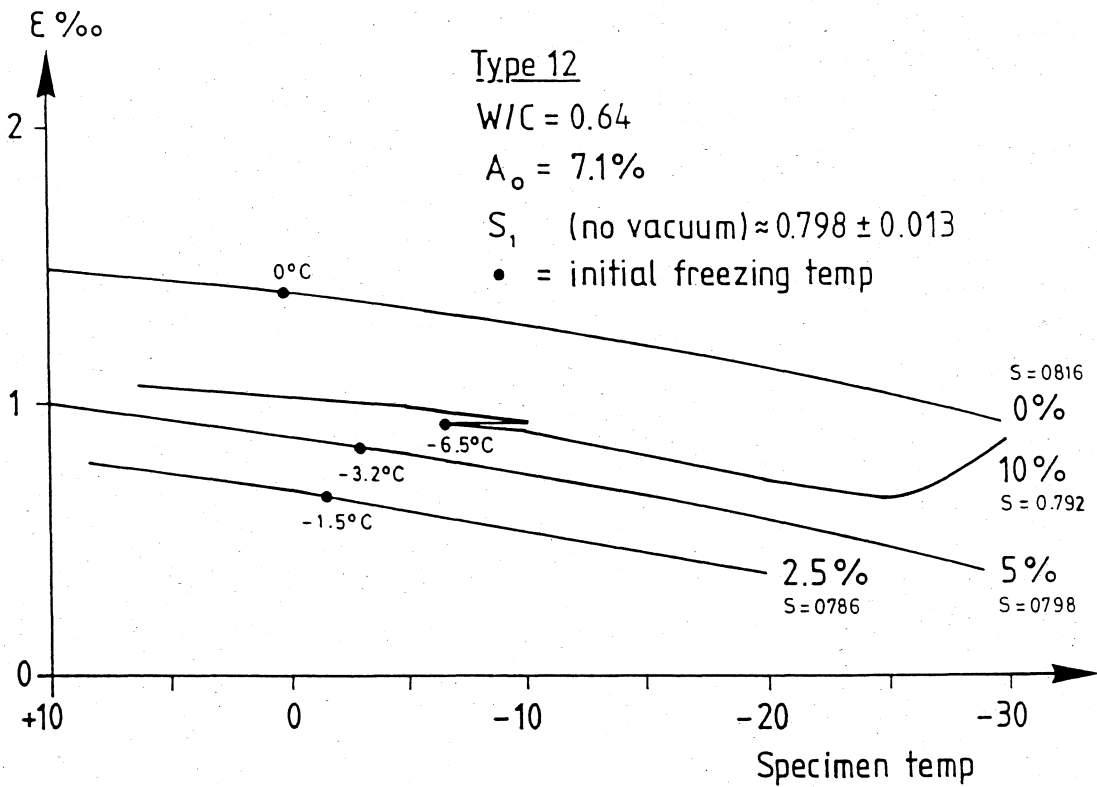

Fig 16: Length-temperature curves of mortars of type 12 (w/c=0,60; air content 3,7%).

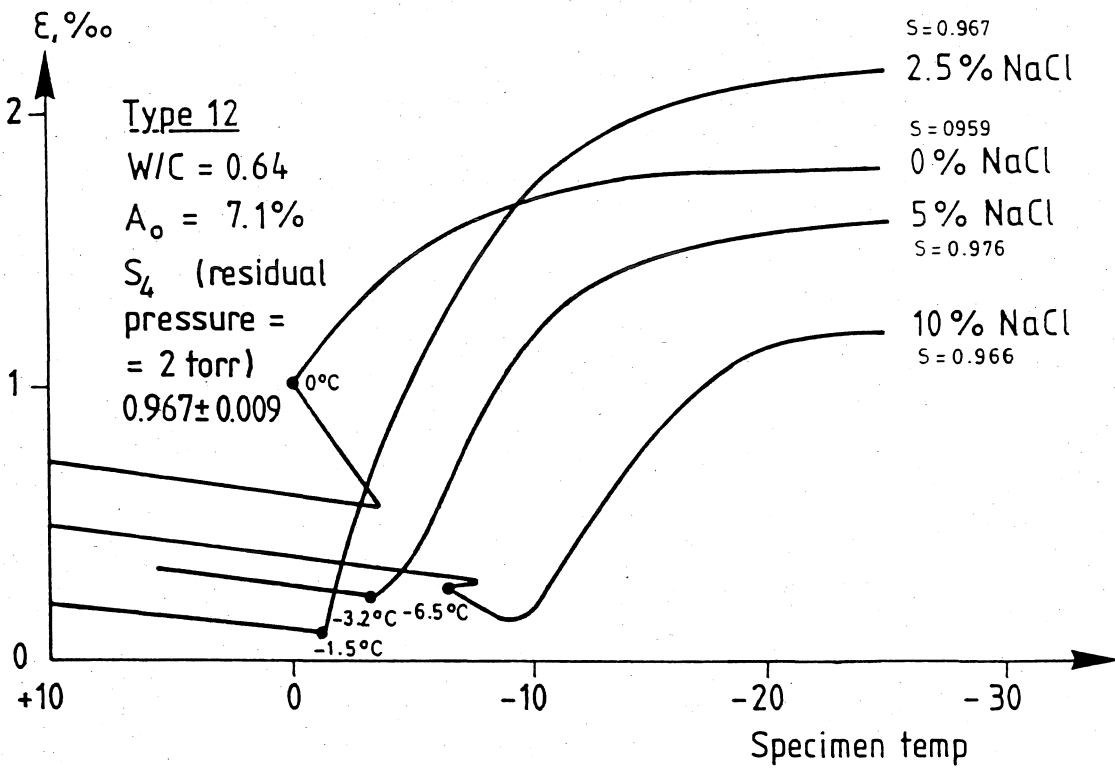
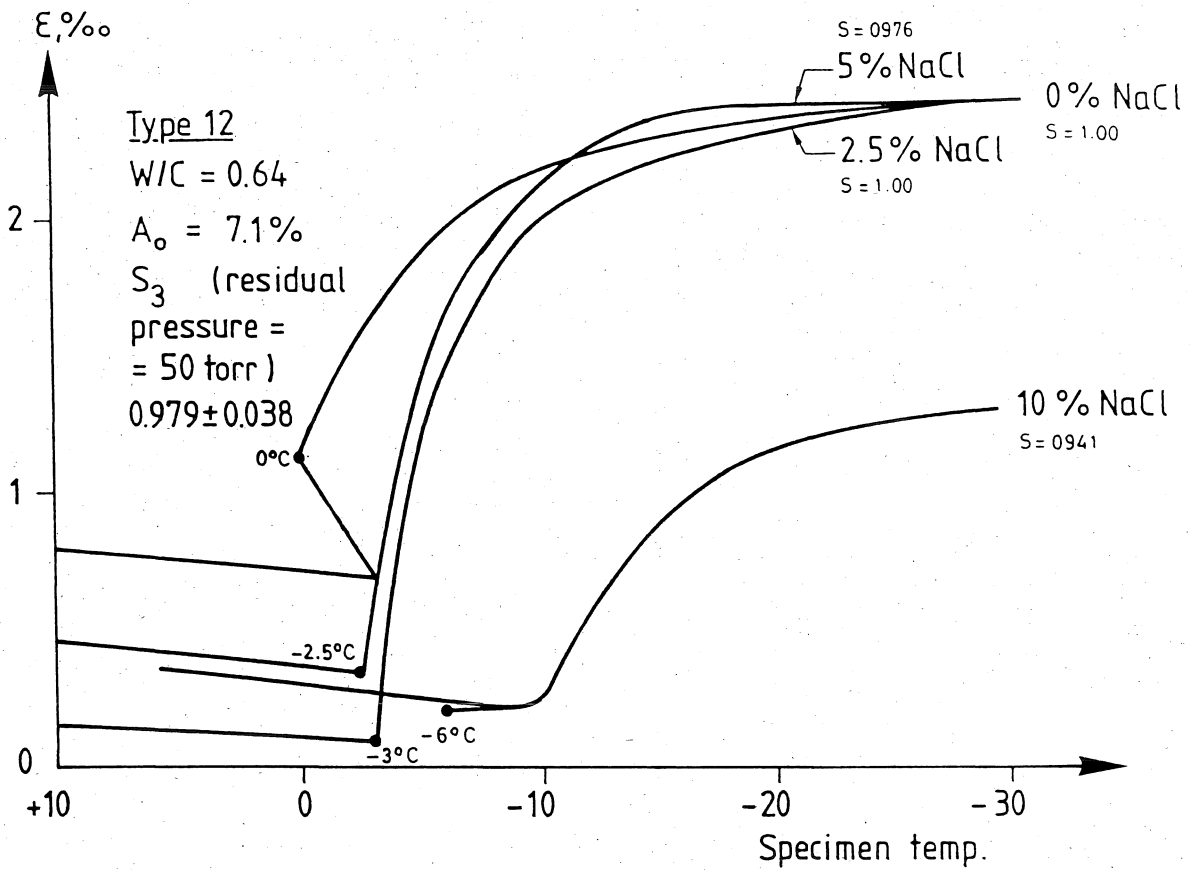

FIG 16: Continued.

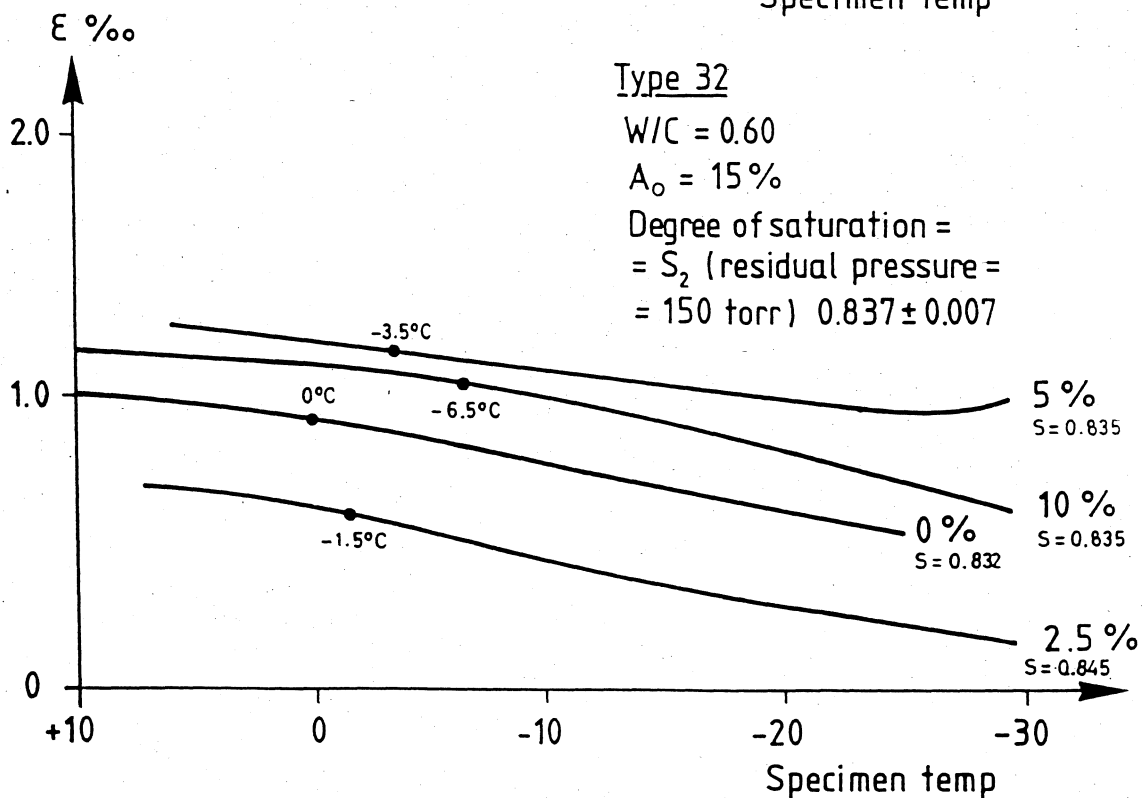
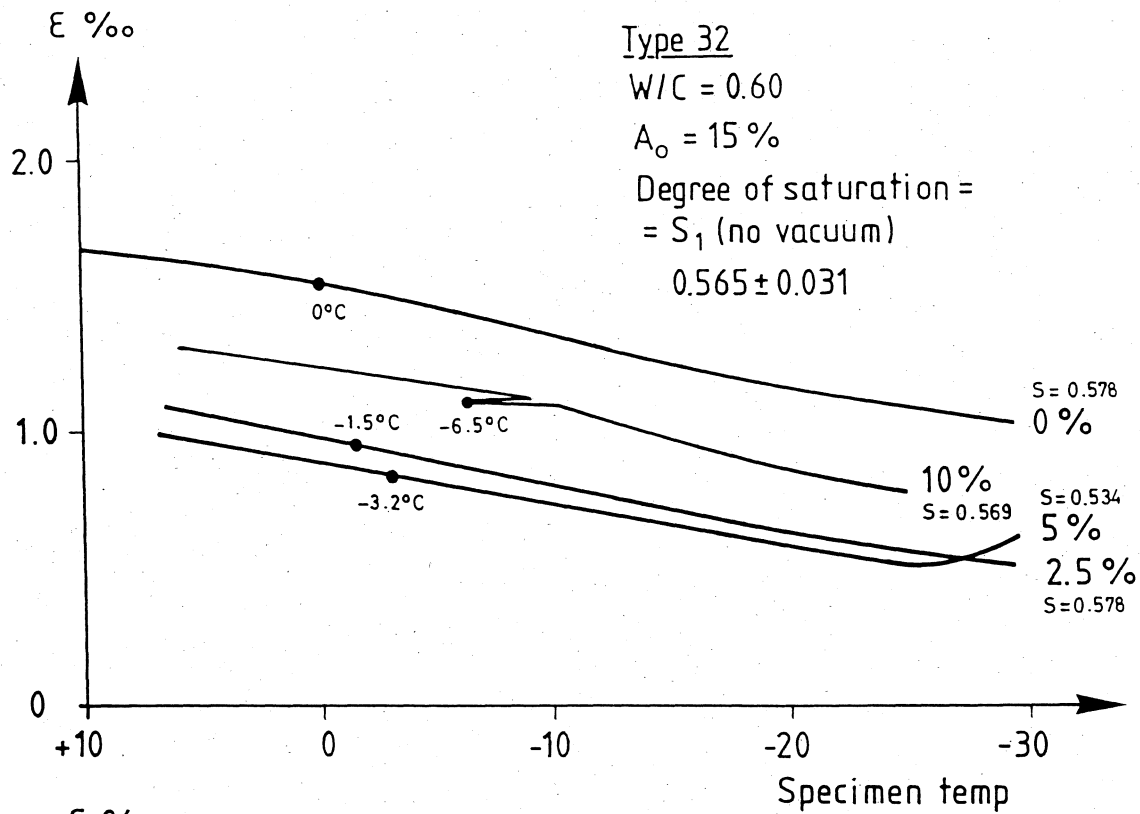

Fig 17: Length-temperature curves of mortars of type 32 (w/c=0,60; air content 8,4%).

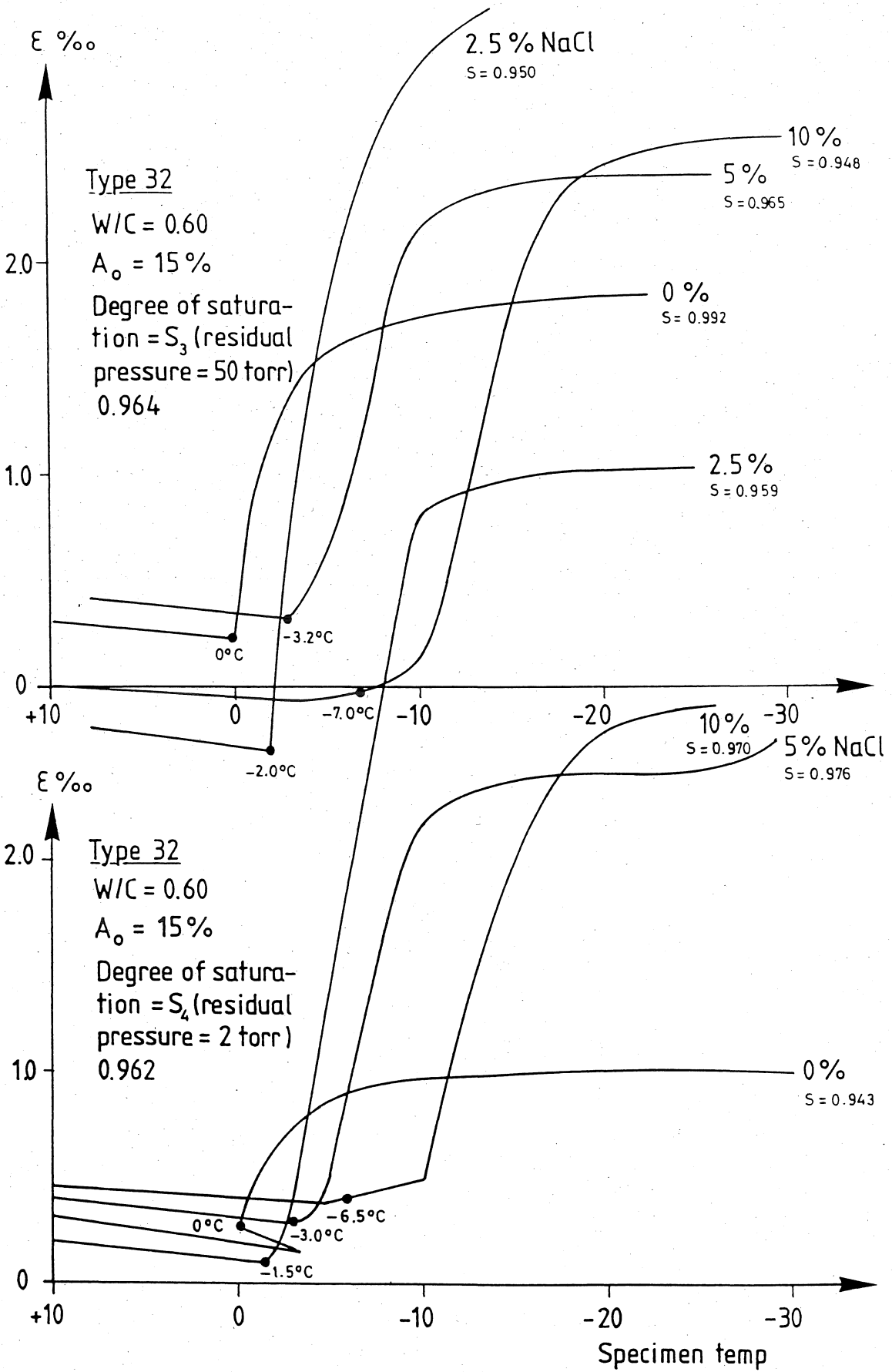

FIG 17: Continued.

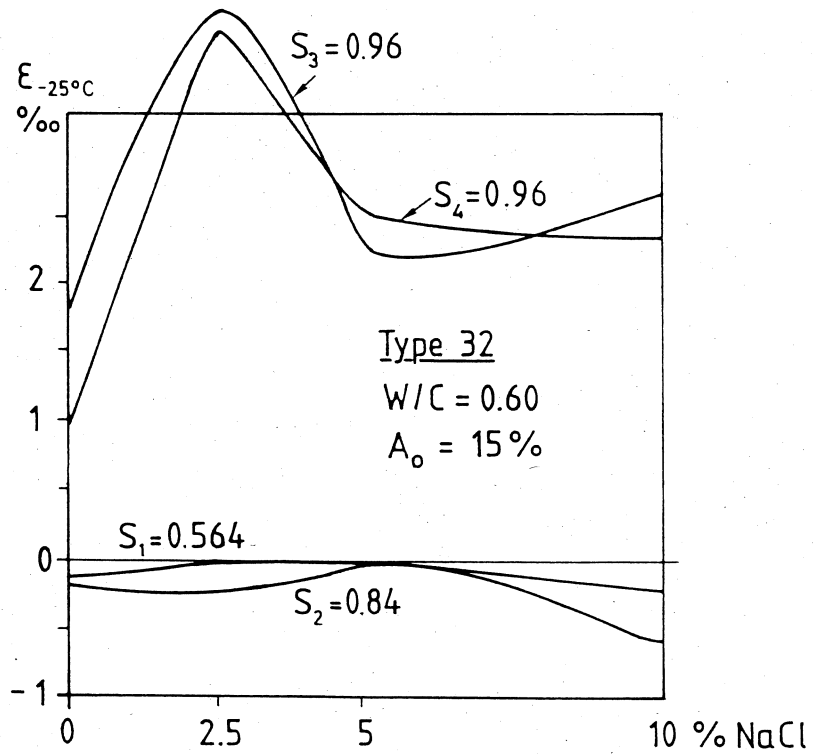
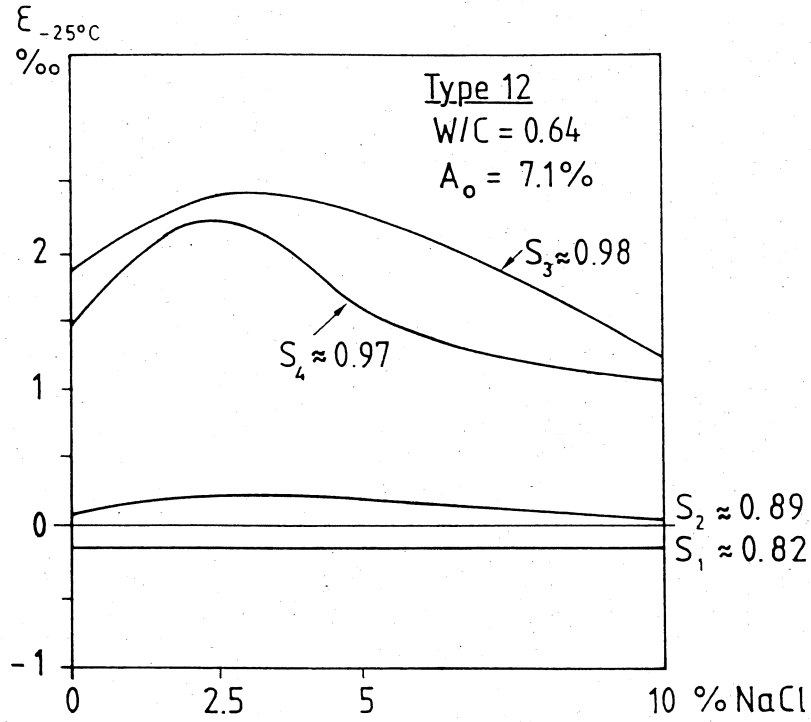

Fig 18: The dilation at -25°C as function of the degree of salt water saturation and the salt concentration of the pore water.

APPENDIX 1: Mix proportions.

Table A.1: Mortars for tests 1 and 2.

Mortar (litt)	sand kg/m ³	cement kg/m ³	w/c	air %
11	1367	623	0,424	3,5 [±] 0,3
21	1333	597	0,423	6,6 [±] 0,1
31	1335	575	0,424	7,9 [±] 0,5
12	1517	383	0,642	7,1 [±] 0,3
22	1460	362	0,640	11,5
32	1398	347	0,605	15,0
13	1563	344	0,701	5,7 [±] 0,1
23	1502	320	0,734	10,4
33	1548	296	0,741	11,0

Table A.2: Mortars for test 3.

Mortar (litt)	sand kg/m ³	cement kg/m ³	w/c	air %
12	1530	412	0,600	3,7
32	1550	378	0,600	8,4

APPENDIX 2: Photos of freeze-tested specimens.

All specimens are turned upside down in comparison with the position during the test.

The 4 specimens to the left are pre-cured according to method 1; air-drying.

The 4 specimens to the right are pre-cured according to method 2; water storing.

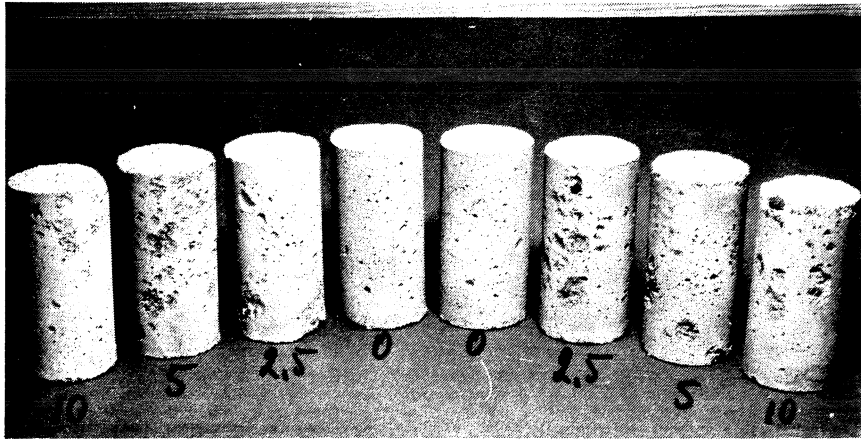

Photo 1: Mortar lutt 11 (w/c=0,42; air 3,5%).

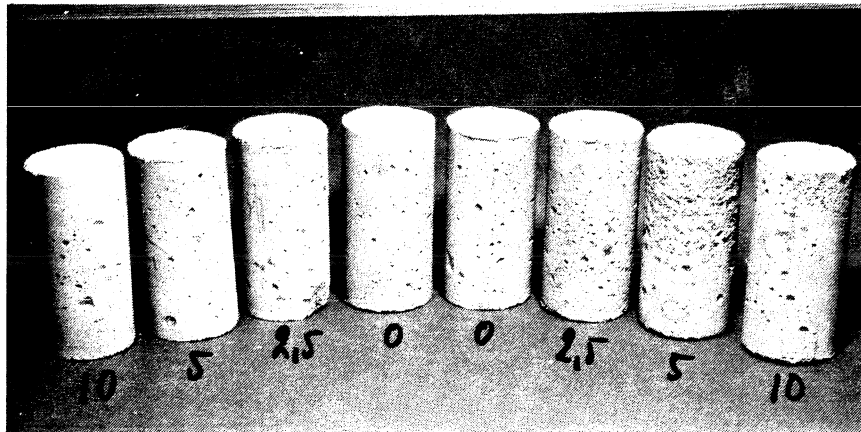

Photo 2: Mortar lutt 21 (w/c=0,42; air 6,6%).

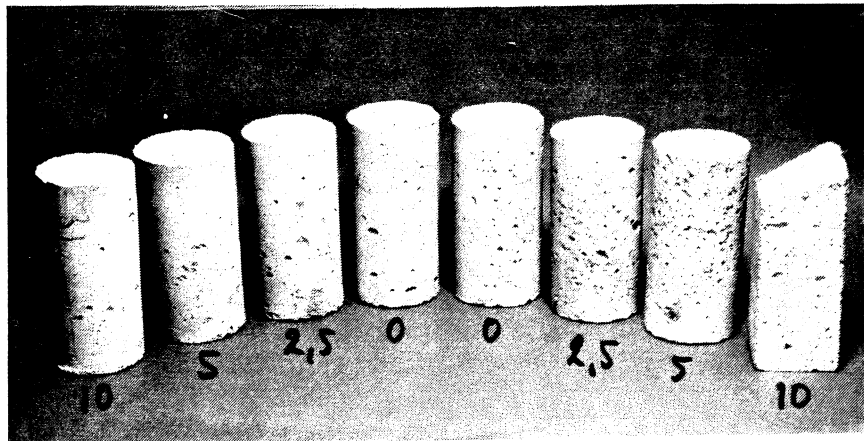

Photo 3: Mortar lutt 31 (w/c=0,42; air 7,9%).

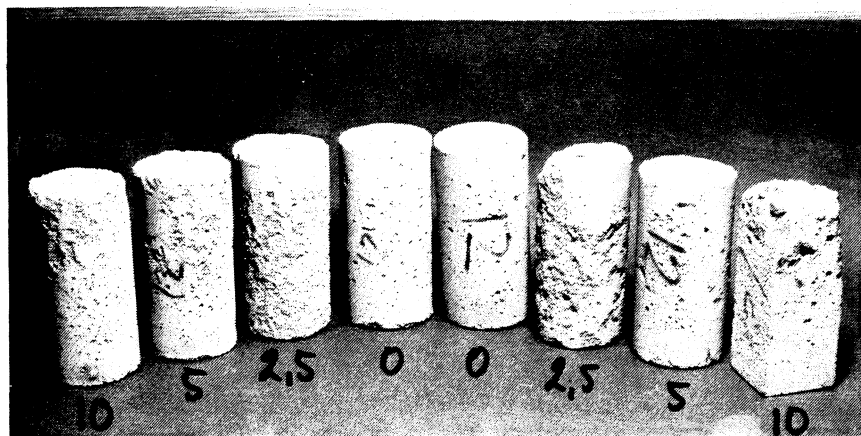

Photo 4: Mortar lutt 12 (w/c=0,64; air 7,1%).

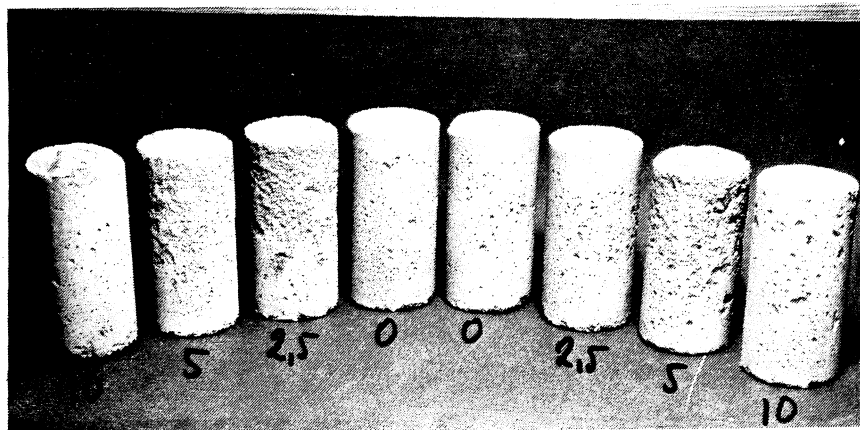

Photo 5: Mortar lutt 22 (w/c=0,64; air 11,5%).

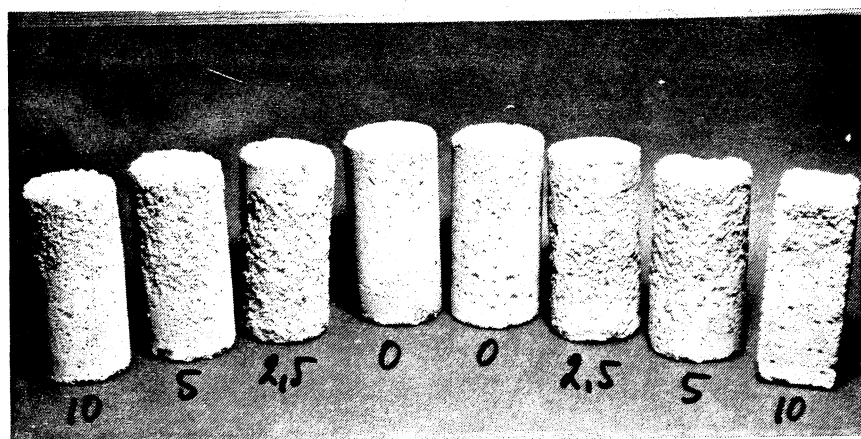

Photo 6: Mortar lutt 32 (w/c=0,61; air 15,0%).

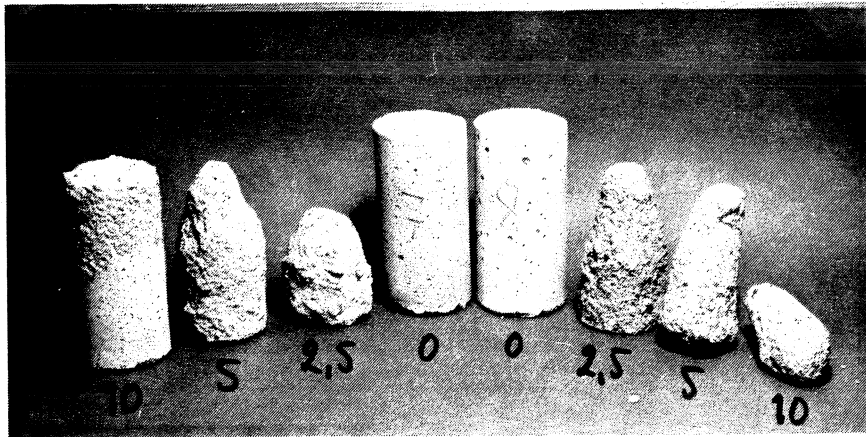

Photo 7: Mortar lutt 13 (w/c=0,70; air 5,7%).

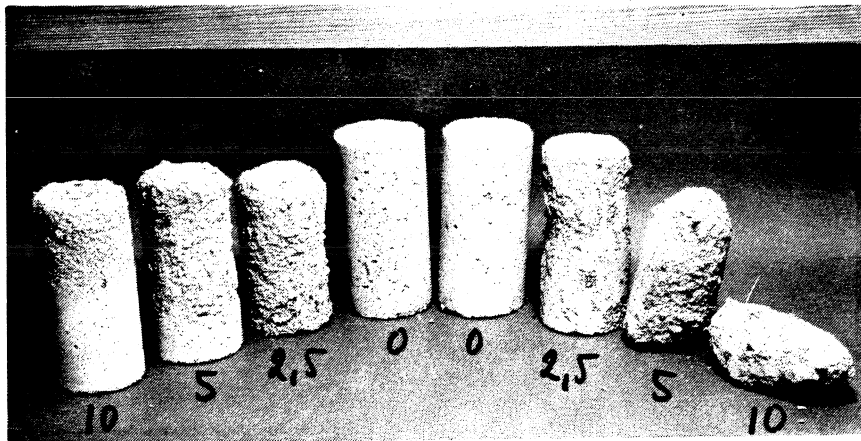

Photo 8: Mortar lutt 23 (w/c=0,73; air 10,4%).

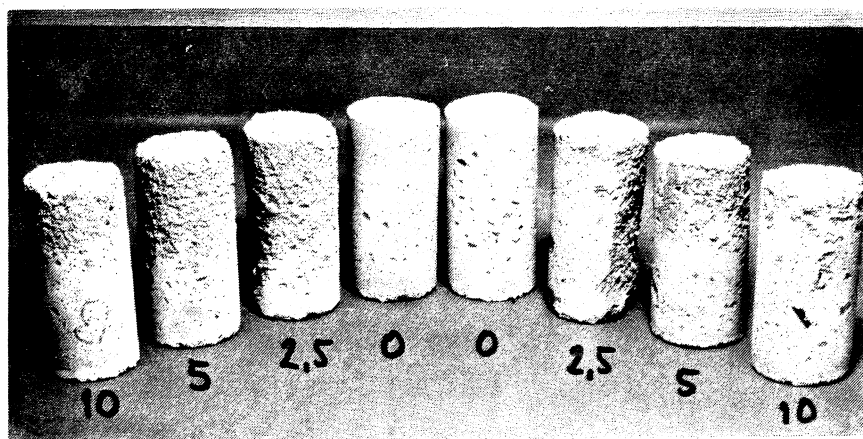

Photo 9: Mortar lutt 33 (w/c=0,74; air 11,0%).

EXPERIENCE WITH AN IMPROVED FREEZE-THAW AND DE-ICING TEST

Volker Hartmann

University of Essen
Essen, Germany

Experience with an improved freeze-thaw and de-icing test

Volker Hartmann

University Essen, Universitätsstr. 15, 4300 Essen, Germany

Introduction

There are quite a number of testing methods [1,2,3,4,6,7,8,9,10,11,13,15] with which it has been tried during the last few years to define an acceptance criterion for freeze-thaw resistance. In spite of this large number of testing methods it was not possible so far to develop a procedure with low test error and sufficiently clear results. Furthermore these testing methods are usually difficult to apply, lengthy and expensive.

State of research

During the last years, the phenomena of freeze-thaw of de-icing salt attack in concrete structures has been investigated in basic research [5,10,14,16]. In the case of freeze-thaw damage, several phenomena overlap and influence the degree of the damage. The freezing behaviour can only be explained correctly if the special physiochemical behaviour of the pore water in the microstructure is taken into consideration. The measuring methods therefore can only be improved successfully if the mechanisms which lead to damage are known and can be taken into account.

On the basis of the research findings it was possible to analyse the testing procedures. The most important results are presented in the following.

A testing procedure should reflect the natural boundary conditions. The boundary conditions in the test must be defined as well as possible, and the relevant testing parameters must be fixed precisely. Tests show, for example, that small variations in the temperature course and in the moisture content of the samples lead to drastic changes of damage [14]

In the case of natural frost attack, there is usually a uni-axial temperature gradient, which means, the temperature attacks the concrete surface and freeze the concrete in layers from towards the interior. In the existing procedures the temperature attack is allowed on all

V. Hartmann: Experience with an improved freeze-thaw and de-icing test

surfaces regardless whether whole cubes or certain surfaces are being tested. The temperature gradient is therefore neither uni-axial nor well defined.

The temperature control in the usual freezing chambers does not ensure a precisely defined temperature course. For this reason the testing procedures allow a deviation of up to 16 Kelvin.

A further important aspect in the test is the absorption of moisture or the pore water content. The absorption of moisture must be controlled precisely. This absorption of moisture, however, is not clearly defined in most testing procedures. It is possible to fix a defined pore water or pore solution content if the phenomenon of capillary suction is used. In this case the water content only depends on material pore structure, time and possibly temperature. The test conditions can be defined exactly. The necessary requirements for testing can be met with existing techniques. For this reason, an improved testing procedure was developed on the basis of the existing methods.

CDF Test

(Capillary Suction of De-icing Chemical and Freeze-Thaw Test)

By means of this procedure, the freeze-thaw test is enabled by using the capillary suction of a defined de-icing solution during pre-storage and during freeze-thaw exposure as well as by freeze-thaw cycles.

The test procedure is divided into the following phases.

1. Manufacture and preparation of samples
2. Dry storage
3. Capillary suction at room temperature
4. Freeze-thaw test
5. Determination of the CDF number.

Requirements of the testing procedure

An improved testing procedure can only be efficient if the results are reproducible. For this reason, the following conditions must be observed:

V. Hartmann: Experience with an improved freeze-thaw and de-icing test

- Before the test begins all samples must have been dried comparably. For this purpose, the samples must be dried in laboratory conditions (20 °C room air temperature and 65% relative humidity) before the start of the test.
- Before the freeze-thaw cycles, the concrete must have a water- or solution content which is reached under unfavourable practice conditions.
- The content of water or solution in the samples is decisive. During the test it must therefore be established in a controlled way.
- De-icing salts should be sucked up with the water. Subsequent diffusion of salt into the water-saturated concrete is very controversially discussed by Volkwein [17].
- There must be a uni-axial temperature attack on a defined testing area .
- The temperature attack must be controlled exactly for all samples. This applies above all to the minimum temperature on the surface of attack.
- The temperature cycle must be kept exactly reproducible with an very small deviation from the nominal temperature.

Manufacture and preparation of samples

For the determination of the freeze-thaw-resistance, special test samples are manufactured. The surface must meet particular requirements. The test samples are manufactured in cube forms of 15 cm side length which are divided in the middle by vertical teflon discs. Thus, two test samples are made, having a length of 15 cm and a width of 7 cm. The teflon covered surface is the area, where no releasing agent is used.

The samples are left in the forms to harden during 24 hours and then stored under water for 6 days. At least in the case of Portland cement, this ensures an equal and sufficient hydration at young age.

As well as this kind of sample, which is essentially for concrete of certain composition, it is also possible to test other specimens such as pavement blocks, drill cores etc. by an equivalent method.

After the test samples have reached a sufficient age - in the above case of Portland cement after 28 days - they are weighed and then stored in a climate chamber at a temperature of 20 °C and 65% air humidity (fig.1). After three weeks, the samples have reached a

V. Hartmann: Experience with an improved freeze-thaw and de-icing test

hygral equilibrium condition in the surface layer. A longer drying period is not needed [14].

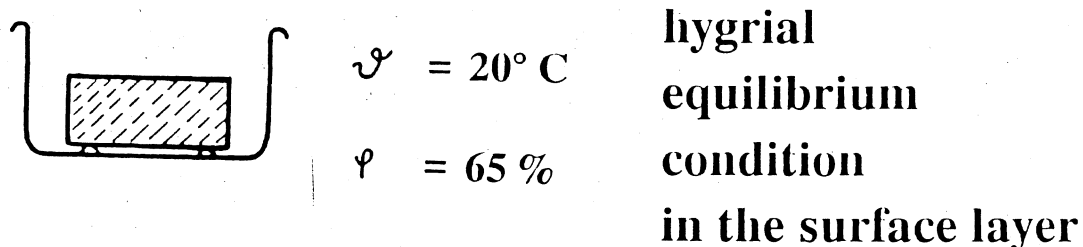

Figure 1. Pre-storage of the test samples

Capillary suction

A test sample is immersed with load surface downwards and immersed 5 mm into a 3% sodium chloride solution in a stainless steel container (fig.2). The test sample is placed on 10 mm high distance spacers. The test container is closed by a cover in order to avoid evaporation of the water out of the test solution. The cover is slanted so that possible condensation cannot drop on the test specimen. Thus, a constant solution concentration is ensured. During a prestorage period of seven days, the water uptake is fixed by the defined physical process of capillary suction. The filling height is checked regularly in order to keep the liquid level constant.

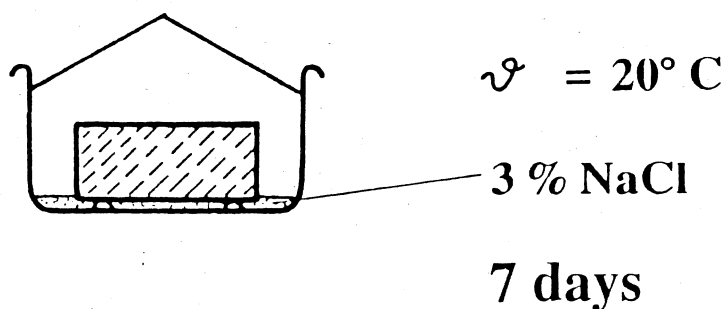

Figure 2. Capillary suction before the freeze-thaw test

Freeze-thaw test

The test cycle suggested and developed by the RILEM Technical Committee 117 in May 1990 is adapted. With steps of 10 Kelvin per hour, the temperature of +20 °C is cooled down to -20 °C. For three hours, the temperature of -20 °C is kept constant, and after that - again at a rate of 10 Kelvin per hour - the temperature is increased to +20° C. This temperature is held for one hour. The temperature cycle is shown in fig. 3.

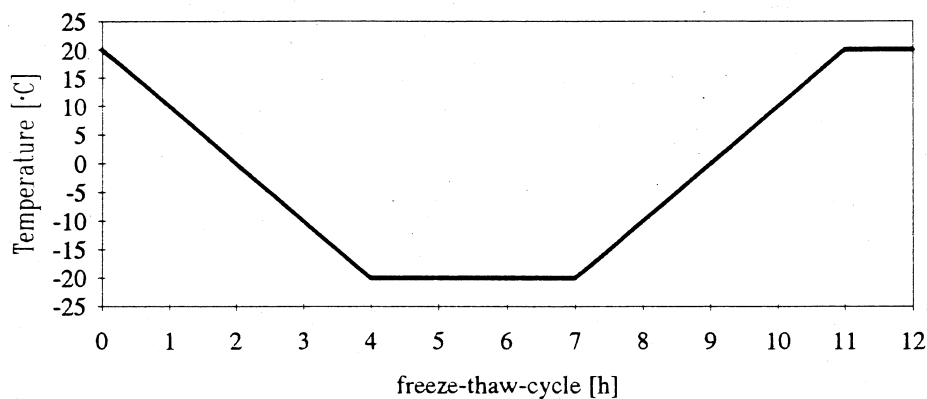

Figure 3. CDF temperature cycle

The actual temperature is measured in the middle of the bottom of the sample containers fig.4. For all test containers the real temperature must follow the required temperature within a deviation below 0.5° C.

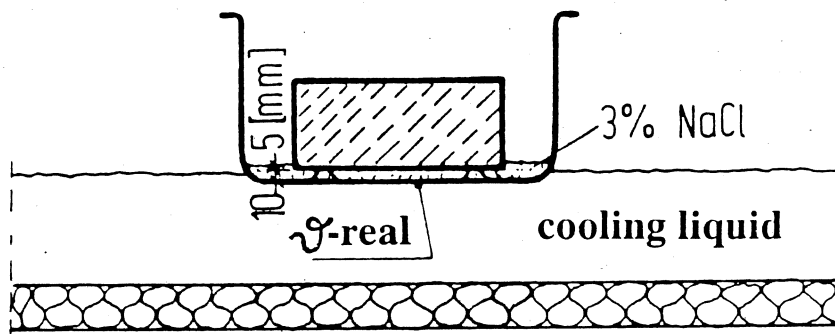

Figure 4. CDF- test system

In an air-cooled climate chamber it is difficult to keep a constant temperature profile for all samples because the smaller heat capacity of the air leads to changes in temperature even in the case of very slight "disturbances", for instance if the chamber is loaded

V. Hartmann: Experience with an improved freeze-thaw and de-icing test

differently. Furthermore, the test samples in the climate chamber must be insulated on all surfaces except the testing surface in order to obtain a uni-axial temperature gradient in the samples.

Experience has shown that a cold bath can be used to meet the requirement of a defined temperature in the sample and during the testing time. Therefore, this method is described here in more detail. The 10 test containers are cooled by immersing them 20 mm into the coolbath. The samples boxes do not need any cover during the freeze-thaw cycles. The closure of the test container avoids evaporation of the solution. The concrete samples are exposed according to the temperature cycle. The temperature load acts vertically on the surface and a uni-directional attack is produced due to the higher heat capacity and the circulation of the bath liquid as well as the small thermal conductivity of the surrounding air.

Test results

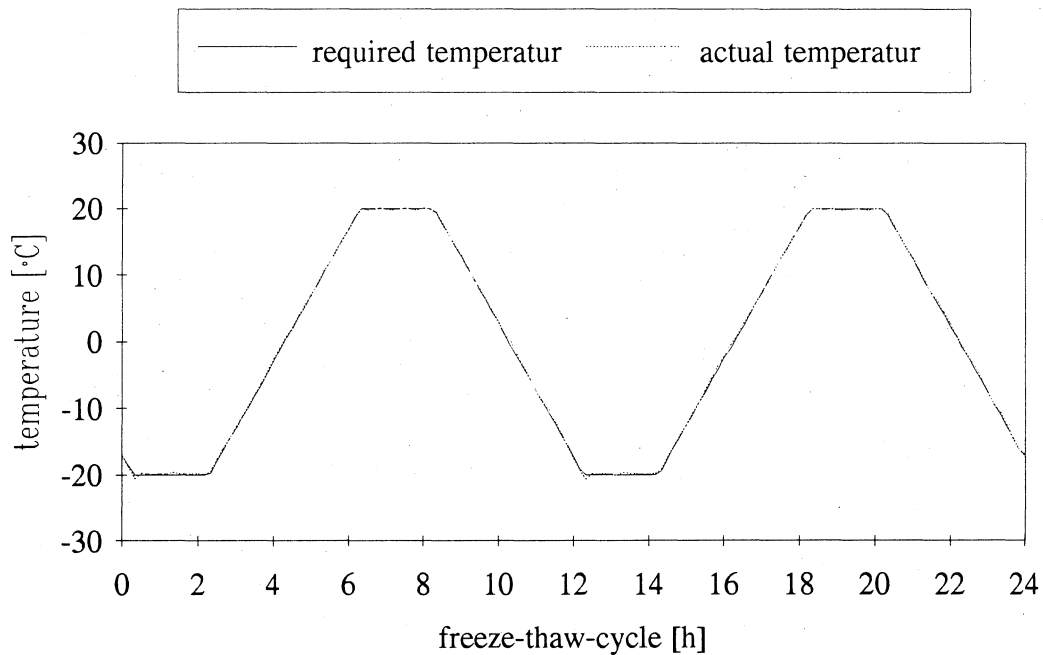

Figure 5. required- and actual temperatur at the bottom of a container in the cooling bath

With the development of a cooling bath much better temperature conditions have been produced as than in the commercial climate chamber. Fig. 5 shows the nominal temperature and the average temperature of five measuring points at the container bottoms. It can be seen that the deviation of the nominal temperature is at most 0.4

V. Hartmann: Experience with an improved freeze-thaw and de-icing test

Kelvin. This small deviation must be reached at any rate in order to have a good reproducibility. Furthermore, an even temperature distribution in the cooling bath is obtained (fig. 6,7). The deviation between the ten containers - measured at the container bottom in the liqued - is 0.3 K.

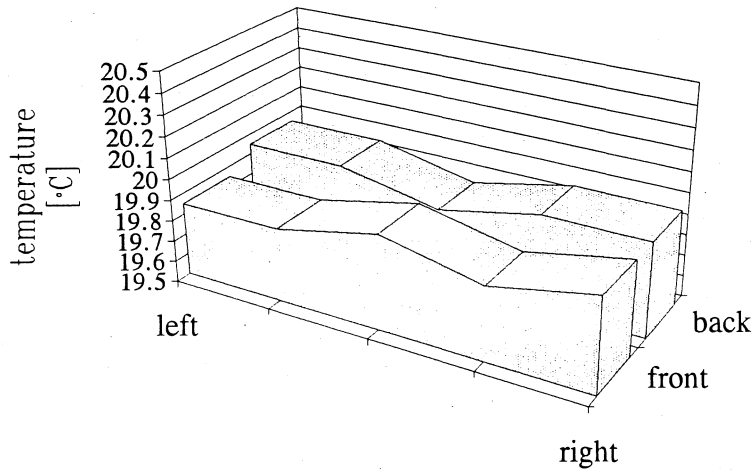

Figure 6. temperature distribution in the cooling bath at 20 °C

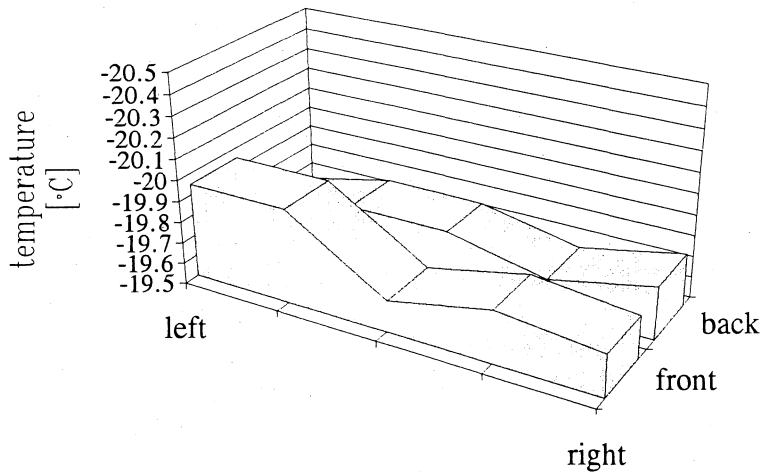

Figure 7. temperature distribution in the cooling bath at -20 °C

By means of this exact temperature control, the CDF test has some important improvements as compared with test procedures so far. A linear increase of weathered material with the number of freeze-thaw cycles is observed (fig.8). This relationship is confirmed in all measuring series.

V. Hartmann: Experience with an improved freeze-thaw and de-icing test

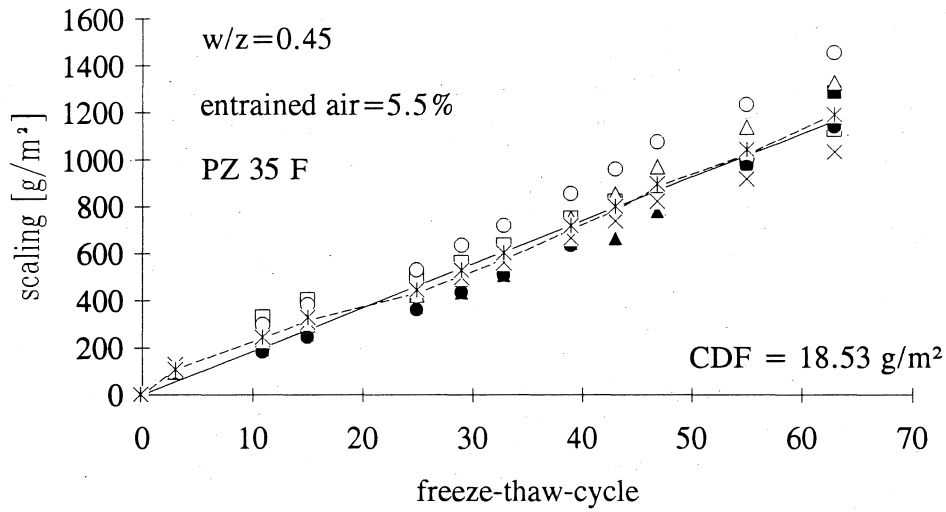

Figure 8. scaling of 10 samples with CDF

There are only exceptions for the case of non-resistant concretes without artificially introduced air pores fig.9. The deviation from the linear relationship is because the sides of the test sample are weather, i.e. the original test area is changed. After a few freeze-thaw cycles, this leads to overproportional weathering (fig. 9) so that in the case of non-resistant concretes the test can be finished with a clear result already after 5 to 10 freeze-thaw cycles (fig.10).

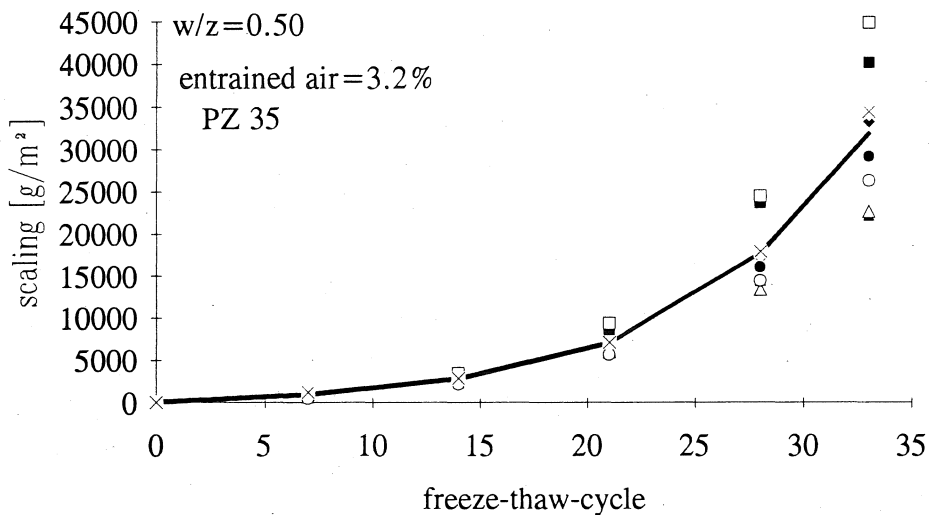

Figure 9. scaling of non-resistant concrete

V. Hartmann: Experience with an improved freeze-thaw and de-icing test

These results show that the scaled-off mass due to weathering is proportional to the number of freeze-thaw cycles if the test has been carried out carefully (fig. 11). A number for the CDF value is sufficient.

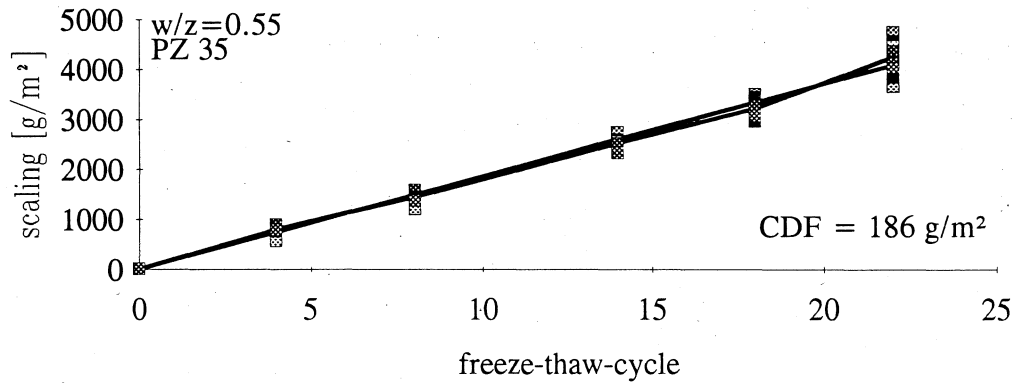

Figure 11. scaling of non-resistant concrete with sealed sides

CDF is the quotient of scaled-off mass m , test surface a and the number of freeze-thaw cycles n .

$$CDF = \frac{m}{a * n} \quad [g/m^2]$$

The criterion used should be the upper 5% certainty.

Error in the measuring results

For the applicability of a test procedure it is very important that the test scattering yields a statistically meaningful result. Figure 12 shows the variation coefficient for series 130. The variation coefficient is less than 0.2 and changes only very slightly with increasing deviation. The data given also apply for other measurements where the variation coefficient sometimes improves. Even in very bad series with samples madewithout entrained air pores, the variation coefficient is as low as about 0.3.

V. Hartmann: Experience with an improved freeze-thaw and de-icing test

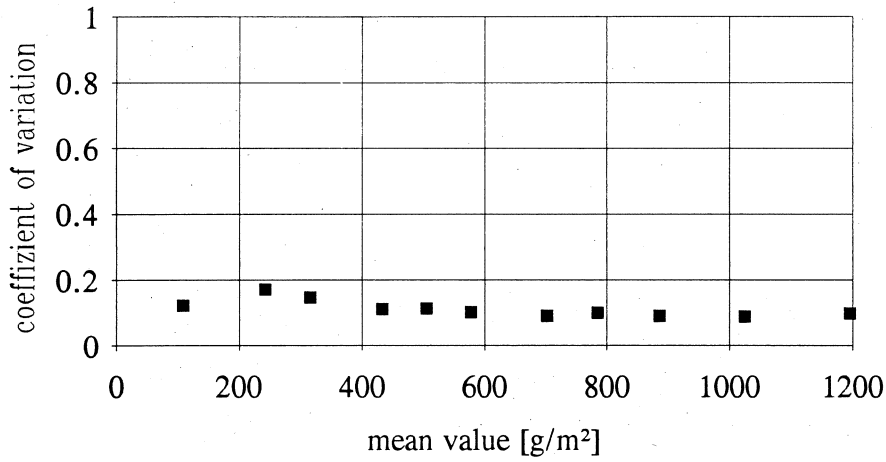

Figure 12. coefficient of variation from figure 8

Comparisons with different temperature cycles, as can be seen in figure 13, show that there is no significant difference between a long 24-hour-cycle and the 12-hour-cycle carried out in this case.

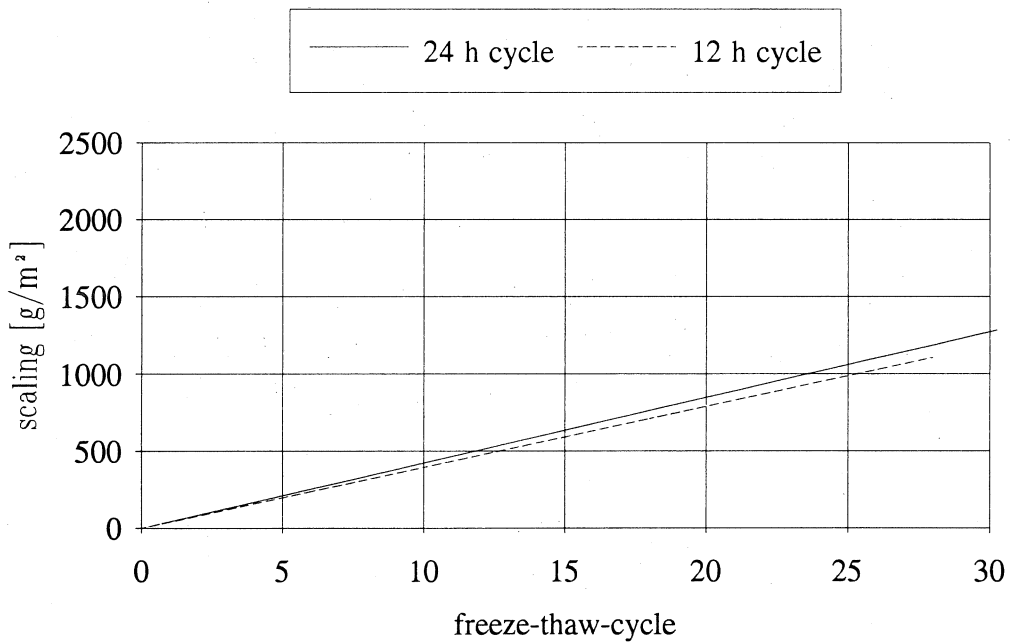

Figure 13. Comparison of temperature cycle duration

V. Hartmann: Experience with an improved freeze-thaw and de-icing test

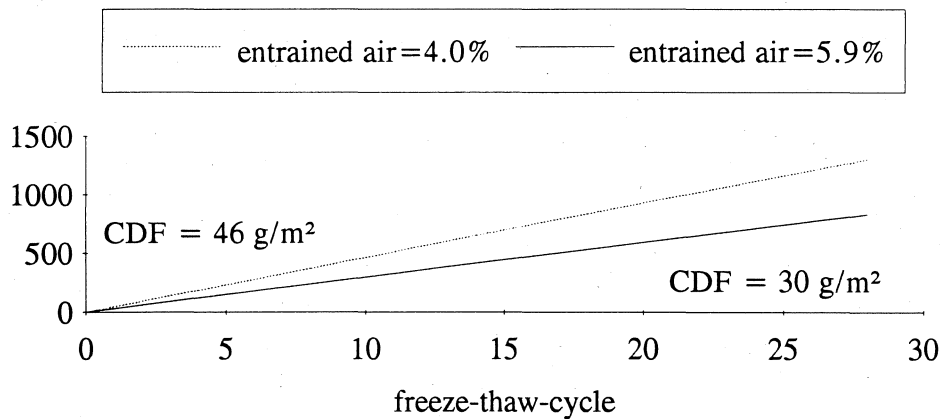

Figure 14. Comparison of weathering from concrete with different air void content

The test procedure meanwhile yields clear and sharp results so that even small differences in the composition of freeze-thaw-resistant concrete can be found. In figure 14, the weathering of concrete with different air content is shown. The concrete was manufactured with a PZ 35 cement. The test was performed after 35 days. This figure clearly shows that the concrete with a air content of 5.9% is more resistant than the air concrete with 4.0% entrained air. Even different sorts of cement can be distinguished at young age. In figure 15 the weathering for a PZ 45 and a PZ 35 is shown. The test age is also 35 days in this case.

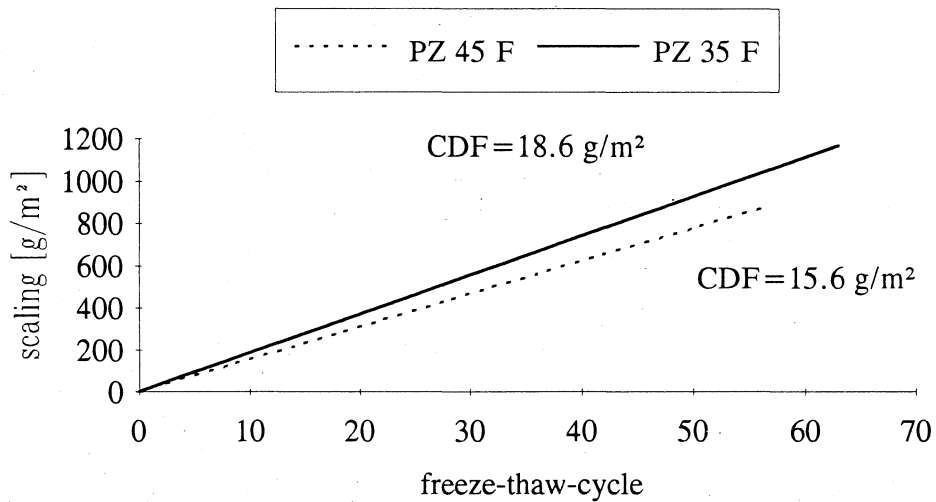

Figure 15. Comparison with different cement, with air entraining admixture

Literature

- 1 ASTM Standard C 666-77: Standard test method for resistance of concrete to rapid freezing and thawing

V. Hartmann: Experience with an improved freeze-thaw and de-icing test

2. ASTM Standard C 672-76: Standard test method for scaling resistance of concrete surfaces exposed to deicing chemicals
3. Bonzel, J. /c Siebel, E: Neuere Untersuchungen über den Frost-Tausalz-Widerstand von Beton. Beton 27(1977), S. 153-158, S. 205-211, S. 237-244
4. Bundesverband Deutsche Beton- und Fertigteilindustrie e.V., Bonn: Überprüfung von Betonzeugnissen aus Beton mit dichtem Gefüge für den Straßenbau auf Frost-Tausalz-Widerstandsfähigkeit. Vorläufiges Merkblatt Januar 1979, Betonwerk und Fertigteiltechnik 45(1979) S. 304
5. Beddoe, R.E.; Setzer, M.J.: A low temperature DSC investigation of hardened cement paste subjected to chlorid action. Cement & Concrete Res. 18(1988), p. 249
6. EMPA: Versuchsrichtlinie Prüfung Nr. 9: Frost-Tausalzverhalten. SIA 162/1 Ziffer 3 09; 2. Aufl. 1987 bzw. 3. Aufl. 1989
7. EMPA: Versuchsrichtlinie Prüfung Nr. 6: Porenkennwerte SIA 162/1 Ziffer 3 06; 2. Aufl. 1987 bzw. 3. Aufl. 1989
8. EMPA: "Versuchsrichtlinie: Schnellporosität", 1989
9. EMPA: Versuchsrichtlinie: Kritischer Sättigungsgrad, 1989
10. Fagerlund, G.: The critical degree of saturation method of assessing the freeze-thaw resistance of concrete. Materials And Structures; 10(1977)58, p. 217 - 229.
11. Fagerlund, G.: Prüfung der Frostbeständigkeit. Int. Kolloquium: Frostbeständigkeit von Beton, Wien 1980, Mitt. VÖZ Heft 33
12. 1. Meeting RILEM TC 117: Freeze-thaw and de-icing resistance of concrete, Essen, 1990, Report, Universität Essen, Bauphysik und Materialwissenschaft
13. ÖNORM B 3306, 9.82: Prüfung der Frost-Tausalz-Beständigkeit von vorgefertigten Betonzeugnissen.
14. Setzer, M.J.: Prüfung des Frost-Tausalz-Widerstandes von Betonwaren, Forschungsberichte aus dem Fachbereich Bauwesen, Heft 49, Universität Gesamthochschule Essen, April 1990
15. TFB(Schweiz): Prüfung von Festbeton auf Frost- und Frost-Tausalz-Beständigkeit. Cementbulletin 54(1986) 10
16. Int. Kolloquium: Frostbeständigkeit von Beton. Wien 1980, Mitt. VÖZ Heft 33
17. Volkwein, Andreas: Untersuchungen zum Eindringen von Wasser und Chlorid in Beton, Dissertation, TU München, 1991

**FROST/SALT-TESTING OF CONCRETE. EFFECT OF TEST
PARAMETERS AND CONCRETE MOISTURE HISTORY***

Erik J. Sellevold

Division on Concrete Structures, The Norwegian Institute of Technology
Trondheim, Norway

and

Tom Farstad

Norwegian Building Research Institute
Oslo, Norway



FROST/SALT-TESTING OF CONCRETE:
Effect of Test Parameters and Concrete
Moisture History

by

Erik J. Sellevold
Ph.D., Professor
Division on Concrete Structures
The Norwegian Institute of Technology

and

Tom Farstad
Researcher
Norwegian Building Research Institute,
Oslo

ABSTRACT

Based on the Borås-method (SS 137244) for frost/salt-resistance a large experimental program has been carried out at five Scandinavian laboratories. An initial Round-Robin test established reasonable reproducibility. It was concluded that concrete inhomogeneity was the main cause of variation in the test results. A systematic study was carried out on the effects of concrete moisture history before testing and on the effects of variation in the following test parameters:

- 1) temperature cycle characteristics,
- 2) the salt concentration on the test surface,
- 3) the salt concentration in the concrete pore water.

The effects of silica fume on scaling has been investigated as well the question of whether high strength concrete needs air entrainment to be frost/salt-resistant.

Key words: concrete, frost resistance, test method

1 INTRODUCTION AND BACKGROUND

Deterioration of concrete due to frost action is not a general problem in Norway. Most of the damage occurs in connection with salts (deicing or from natural sources), but then frequently with quite severe scaling as a result. The situation in the other Nordic countries is similar in that damage is generally associated with salts, but it also appears to be more prevalent than in Norway, according to published national status reports (1). Outdoor concrete not subjected to salts is generally protected by correct air entrainment, unless the exposure results in a very high degree of water saturation at freezing.

The most important practical problem is consequently to ensure frost/salt-resistance. One important aspect is a reproducible and relevant test procedure. In Sweden a saltscaling method (SS 137244, referred to here as the Borås-method) has been developed, which has proven reproducible - at least internally.

The goal of the present project was to investigate the influence of various concrete compositions and curing/moisture-histories on the salt scaling. A prerequisite to this task is of course to have a reliable test method. It was decided to base the work on the Borås-method and to carry out the work in 3, partly overlapping, stages:

- 1) Round-Robin tests at 5 laboratories in 3 countries
- 2) Carry out experiments where important test parameters of the Borås-method were varied systematically:
 - The temperature cycle characteristics
 - The salt concentration on the surface during the test
 - The initial saltconcentration in the concrete pore water
- 3) Vary the moisture history of a given concrete before testing. The main point was to subject the concrete to different drying/resaturation treatments before testing. Low temperature calorimeter measurement have shown such treatment to influence the iceformation pattern drastically, Sellevold and Bager (4). Similar drastic effects on the saltscaling was expected.

22 different concrete mixes were tested in 23 different test series. The basic mixes were with w/c + s - ratios of 0,55 and 0,45, air-entrained with and without silica fume. A number of high strength concretes (> 65 MPa) without air entrainment were also tested.

The five laboratories taking part in the work was:

CBL: Cement- og Betonlaboratoriet, Aalborg Portland,
Denmark
SP: Statens Provingsanstalt, Borås, Sweden
FCB: Forskningsinstituttet for Cement og Betong, SINTEF,
Trondheim, Norway
NBI: Norges Byggforskningsinstitutt, Oslo, Norway
NOR: Norcem Betonglaboratorium, Brevik, Norway

The Round-Robin test is reported in full (2), as is the rest of the experimental work (3). This article presents a number of representative results from both reports and sums up the main conclusions. It should be noted that the extent of the experimental results is large and because space is limited the report focuses on presenting results, rather than interpreting these in terms of mechanisms.

2 THE ROUND-ROBIN TEST

2.1 The Borås-method (SS 137244)

The Borås-method is a saltscaling test method similar to ASTM C 672, but with a number of details improved. The test specimen (about 50 mm thick, cut from a cylinder, cube or prism) is insulated on the side - and bottom surfaces. The test surface is covered with a 3 % NaCl solution 3 mm deep. About 20 mm above the solution a thin plastic foil is stretched to prevent evaporation of water from the solution during testing. The insulation ensures that freezing is one-dimensional and initiates at the test surface. Fig. 1 shows a prepared test specimen and the characteristics of the 24 hours temperature cycle. The temperature is measured in the salt solution.

The amount of scaled material is measured at 7, 14, 28, 42 and 56 cycles, and recorded as dry material per m^2 concrete. At 56 cycles a concrete is rated on the following scale: ACCEPTABLE $< 1 \text{ kg}/m^2$, GOOD $< 0,5 \text{ kg}/m^2$ and VERY GOOD $< 0.1 \text{ kg}/m^2$, with the additional requirement that the scaling the last 28 cycles shall be less than the first 28 cycles.

For testing of 150 mm cubes four samples are recommended (900 cm^2), while for samples taken from structures a minimum test surface of 400 cm^2 is recommended.

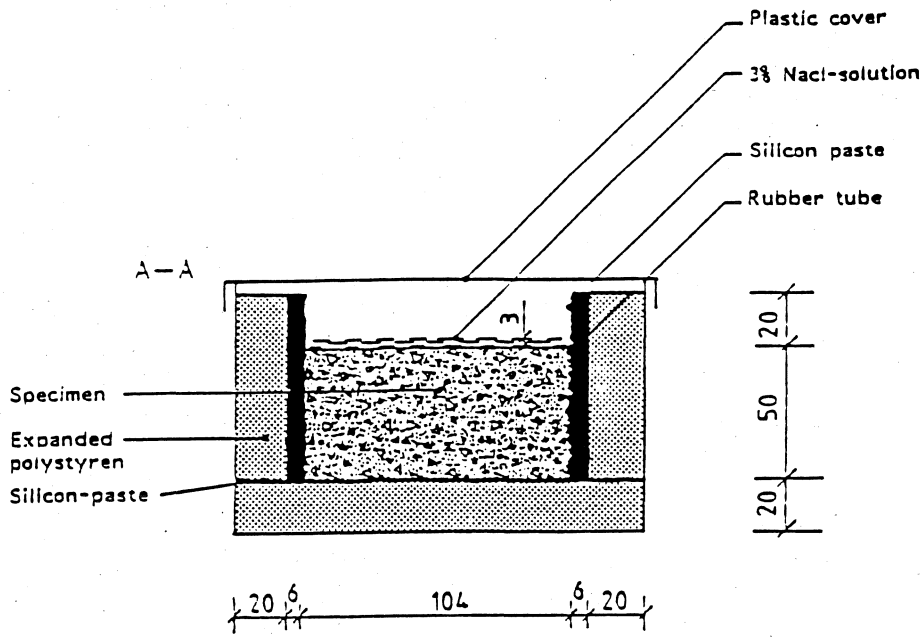

Specimens prepared for SS 13 72 44 freeze/thaw test

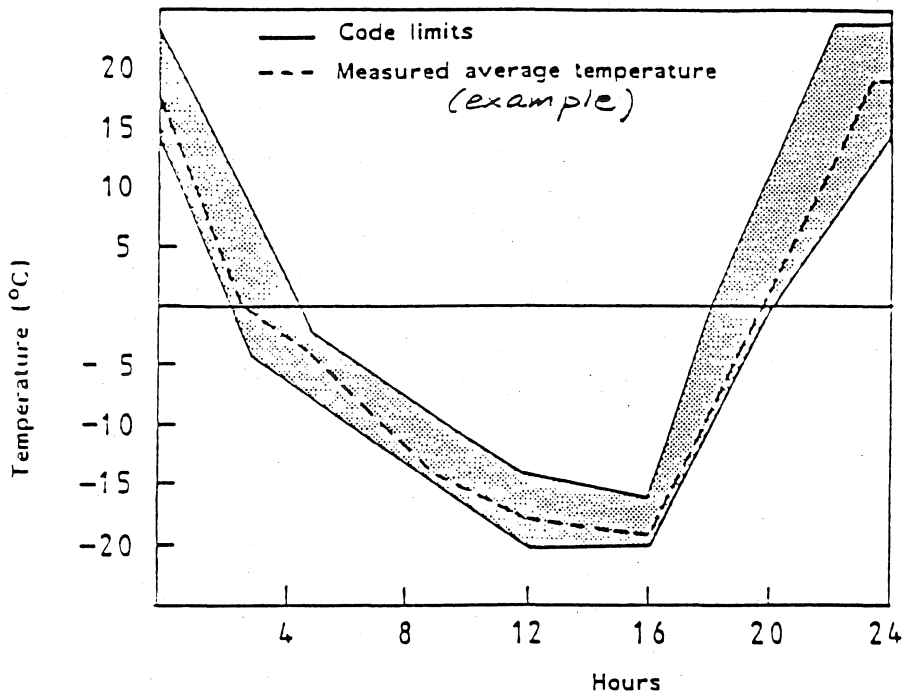

Freeze/thaw cycle according to SS 13 72 44

Fig. 1 The Borås-method: Specimen preparation and temperature cycle

2.2 REPRODUCIBILITY

The Round-Robin test included 9 concretes, all produced at NOR in the form of prisms 150 x 150 x 1000 mm. 50 mm slices were cut from the prisms for testing. 4 laboratories tested at about the same time at a concrete age of minimum 3 months (sealed curing), while one laboratory started 14 months later. Their results were somewhat different and are reported in section 3.1.

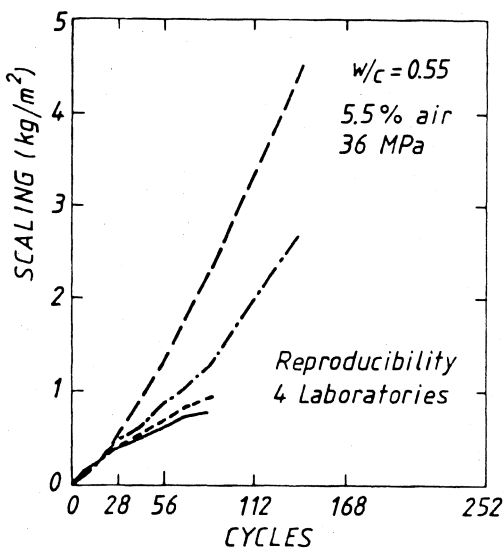

Fig. 2a Scaling for concrete B1. Mean values including all test specimens

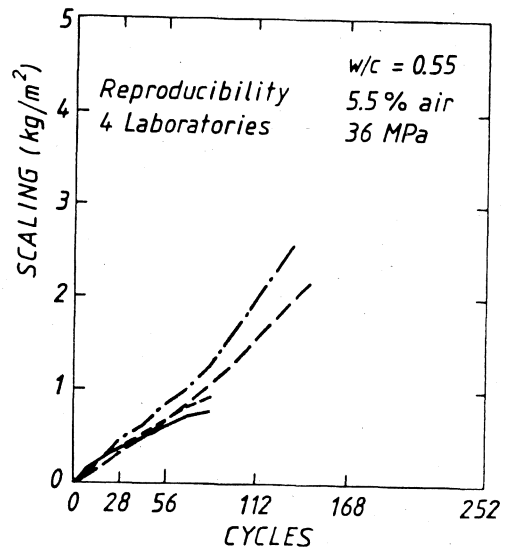

Fig. 2b Scaling for concrete B1. Mean values with one specimen excluded at one laboratory

Fig. 2a shows scaling for concrete B1 in the form of mean values for 4 plates at each laboratory; while in Fig. 2b one plate is left out for one laboratory. As can be seen, one deviant specimen changes the concrete rating from ACCEPTABLE to UNACCEPTABLE at one laboratory, while the other 3 rates the concrete ACCEPTABLE. For other concretes similar deviations were observed, particularly for concretes with marginal ratings. For less sensitive concretes, i.e. VERY GOOD rating or with very high scaling, the ranking by the different laboratories was more consistent.

The reasons for the deviations are uncertain. The scaling was generally not a homogeneous phenomenon but occurs in concentrated areas (as is the case in practice). Sometimes the reason for high scaling could be edge effects caused by a pocket in the glued on dam around the edge. Leakage of salt solution would result in no scaling. The specimen preparation clearly depends on the person doing it; however, such problems are noted in the test protocol - which was not the case with the deviants discussed above. High scaling sometimes are associated with weak points in the test surface; a cavity, a loose stone etc, i.e. local inhomogeneities.

The position of a specimen in the freezer influences the temperature cycle characteristics somewhat within the allowed band, Fig. 1. Several times when different scaling was observed for two specimens, their positions in the freezer was exchanged for a period. However, this did not change the scaling pattern for either. We therefore do not believe that small changes in the temperature cycle are responsible for the observed deviations. We believe local inhomogeneity in the concrete test surface is the main cause of deviations, rather than extreme sensitivity to variations in the temperature cycle.

It should be kept in mind that any scaling test only tests a very small volume of concrete in contrast to "volume deterioration" methods such as ASTM C 666. But in practice it is the scaling problem we try to solve - hence a scaling method appears most relevant. SP has shown that it is possible to obtain consistently low variation for their own laboratory produced concretes. Such a procedure thus yields the potential frost resistance of a concrete composition. For field specimens the homogeneity of the concrete is also characterized in a scaling test. Results should therefore be reported for individual specimens as well as mean values.

3 EFFECTS OF CONCRETE CURING/MOISTURE-HISTORY AND TEST PARAMETERS

In addition to the 9 concretes for the Round-Robin tests (B1-B9), 13 concretes (B10-B20 plus two, H5 and H7, with the high strength cement P30-4A) were made for additional testing. B13-B20 were produced at readymix plants, and molded in blocks from which cores were drilled and sawn for test specimens. This procedure was followed in the hope of obtaining more homogeneous specimens. However, this turned out not to be the case, particularly for B17-B20 which produced large variation in scaling. Followup investigations showed that the air content and the scaling varied systematically with test specimen location in the blocks. Thus the results presented in this section shows relatively large variations, however, the general pattern of the results are supported by the number of test series and test laboratories. All details and individual results are given in (3).

3.1 Aging effects

As already mentioned one laboratory carried out the Round-Robin tests about 14 months after the other 4 laboratories. All 4 concretes tested displayed more scaling, after the storage in plastic bags which probably involved some drying. It is likely that this increased scaling is caused by the drying/resaturation-effect. Earlier calorimeter - measurement have shown marked increases in iceformation after long term drying at 20°C and RH of 75 and 83 %, before resaturation (4). In normal Borås-procedure drying takes place at 50 % RF for one week before water is placed on the surface 3 days and then replaced by salt solution before testing. The importance of drying/resaturation will be further discussed below.

3.2 Drying/resaturation treatment

When concrete is dried and resaturated (submerged in water) its pore structure is changed substantially. This results in increased permeability and iceformation, indicating a change in the direction of more coarse and continuous pores (1, 4, 5). This is seldom taken into account in concrete testing. The effects of such pretreatment on scaling was investigated in several test series.

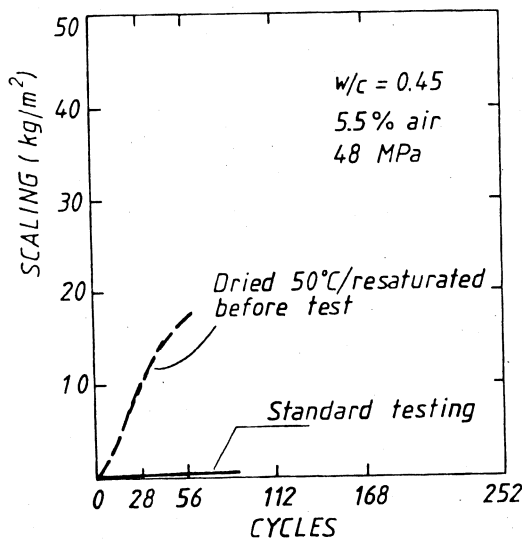

Fig. 3 Scaling before and after drying/resaturation treatment

Fig. 3 shows a typical result. Predrying at 50°C for 10 days followed by one week submersion in water led to at least an order of magnitude increase in scaling. Several other variations in treatment were tried: 2 days at 50°C, 1 day at 105°C and one simulating realistic conditions with 8 hours at 50°C followed by 16 hours at 20°C for a total of 6 days. Individual specimen variation was large and the results as a whole not systematic enough to allow establishment of any critical limit for the treatment. The only general conclusions to be drawn is that any of the pretreatment varieties led to increased scaling, and that concretes containing silica fume (7 % in a 1:1 replacement of cement) were more robust to such pretreatment. 50°C drying is not unrealistic relative to natural exposure of concrete. It is therefore an open question why such treatment increases the scaling in the laboratory so dramatically. For high strength concrete the scaling can be insignificant even after such treatment, see later.

3.3 Curing temperature

The curing temperature was not part of the experimental program. However, the tests showed that concretes B17 and B18 (Fig. 5, for example) had quite high scaling in spite of high strength (ca. 50 MPa) and a good air pore structure $L \approx 0,20$ mm). These concretes were produced in blocks (1000 x 1500 x 400 mm) in a very warm period. The most likely explanation is therefore that a high temperature (over 50°C) the first curing period is responsible. Calorimetric measurements of ice formation in hardened cement paste (6) has shown that even the moderate curing temperature of 45°C increases the iceformation and thereby the damage potential substantially. A systematic followup on this point has recently been reported (7) for concrete cured at 20°C, 40°C and 60°C. Scaling was found to increase markedly with increasing curing temperature.

The clear implication of these results is that strength and air pore structure are not sufficient information to assess frost/salt-resistance of concrete (and probably other durability properties), the curing temperature is also important.

3.4 The Temperature Cycle

There exists little systematic data on the influence of the temperature cycle on frost/salt-scaling. The question is important, at least for two reasons:

- a) The temperature band in the Borås-method (Fig. 1) is quite wide. It is unavoidable that specimens are subjected to different temperature cycles depending on their position in the freezer. How much importance does this fact have for the scaling, and to what extent is it responsible for variations between parallell specimens?

- b) The relationship between laboratory tests and temperature cycles in natural exposure, i.e. how "tough" is a given test method?

We believe the most important aspects of the temperature cycle to be the cooling rate, the minimum temperature and the time spent at freezing temperatures. Increased cooling rate is normally expected to increase the damage potential due to increased rate of ice formation. With salt, however, it is probably an osmotic type mechanism which dominates, and it is less clear what to expect. Time at freezing temperatures would be expected to be important since an osmotic mechanism involves transport of mass which requires time. The minimum temperature determines the amount of ice formation, and would certainly be expected to be important regardless of damage mechanism.

Several test series were carried out on these points. Different cooling rates and minimum temperatures were achieved partly by changing the specimen insulation (by placing the evaporation preventive foil directly on the salt solution) in the normal freezer, partly by using a freezer with larger cooling capacity. In two series the specimens were removed from the freezer on reaching about -18°C in each cycle and stored at $+20^{\circ}\text{C}$ until the next cycle. This cycle is referred to as in/out, and was included in order to minimize the time the specimens spent at low temperature. Fig. 4 shows the different temperature cycles obtained.

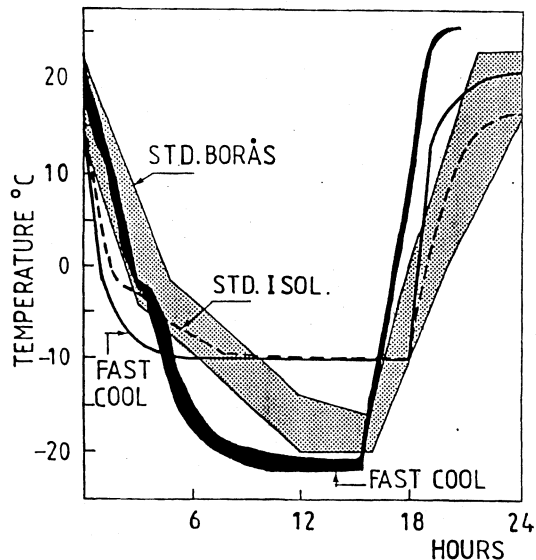

Fig. 4 Achieved temperature cycles in normal freezer (-20°C) and more powerful freezer (-10°C). Fast cool refers to specimens with less insulation (plastic foil in contact with salt solution)

The main conclusion from these test series were (3):

- Increased cooling rate to a fixed minimum temperature does not lead to significant changes in the scaling. In addition: Attempts to detect a systematic relationship between scaling and specimen position in the freezer did not succeed, in spite of a clear relationship between position and temperature cycle. We therefore conclude that temperature cycle variations within the allowed Borås limits (Fig. 1) cannot explain the large variations in scaling often found in routine testing. We believe concrete inhomogeneity is the main source.
- The minimum temperature has significant influence on the scaling. The -20°C used in the Borås-method was found to produce more than twice as much scaling as the -10°C used in a parallell test. This observation is clearly important in evaluating the "toughness" of the Borås-method relative to natural exposure.
- The In/out-variant produced significantly less scaling than any of the others regardless of minimum temperature. This observation indicates that pressures generated in the first strong freezing (hydraulic or direct ice-matrix) is not the main cause of scaling. It is clearly necessary with time to build up pressure, indicating an osmotic type mechanism.

3.5 Salt concentration on the surface

It appears to be generally accepted that 3 % NaCl solution is "pessimal" with regard to scaling. This concentration is used in most test methods, but little recent documentation exists on this point. It is not unreasonable to expect that the "pessimal" concentration varies with concrete quality. Several test series were therefore carried out, on a variety of concrete qualities. Figs. 5 and 6 shows some results. Fig. 5 give the results on two concretes tested at two laboratories. The variation was quite large (caused by the already mentioned inhomogeneity of B17 and B18), but the tendency is consistant; there is a "pessimal" value near 3 % NaCl.

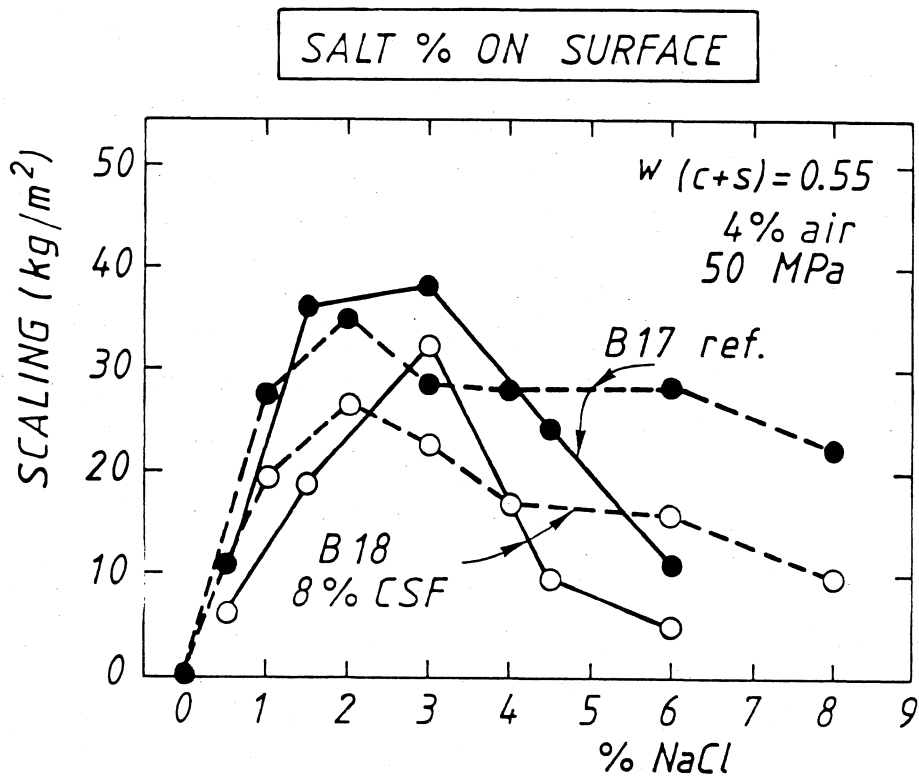

Fig. 5 Scaling with different salt concentrations on the test surface

For high strength concrete (Fig 6) no pessimal value at 3 % is indicated, rather the oposite. The effect of salt concentration is not very large, however, and does not result in altered rating of the concrete. The most striking aspect of the results is the total lack of scaling when pure water is used, and that as little as 0,5 % NaCl has a very significant effect. We lack basic understanding of the mechanism to explain this consistent observation. At least it indicates that a very high degree of saturation in the surface larger alone is not sufficient to explain scaling - since it is difficult to imagine that a small amount of salt would greatly influence this factor.

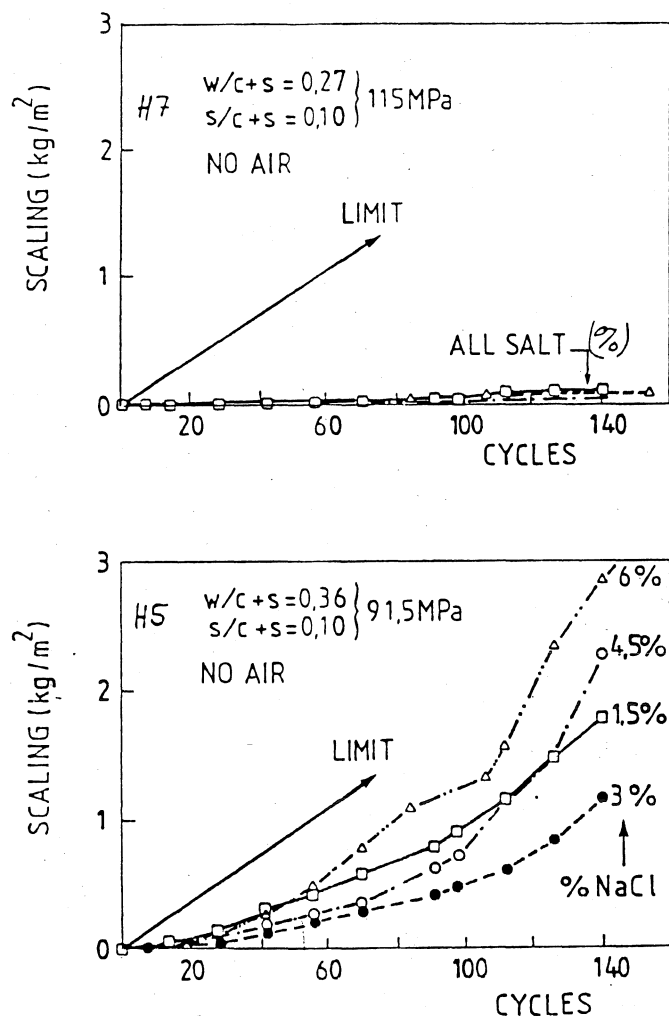

Fig. 6 Scaling of two high strength concretes made with high strength cement P30-4A

3.6 Salt concentration in the pore water

Specimens were dried at 50°C and then submerged in salt solutions with NaCl concentrations from 0 to 12 %. Fig. 7 gives the results for one series. Note that the level of scaling is much lower for B20 with silica fume than B19 without. This was found in practically all series. The concretes were quite inhomogeneous, but the results indicates that resaturation with pure water produces largest scaling. Calorimetric measurements on similarly treated pastes showed, as expected, that pure water produced faster and more iceformation at a given temperature, Fig. 8 (8). Thus our general experience that scaling and iceformation are related in this qualitative way is confirmed by these results. Many conflicting reports exists in the literature on the effects of salt solutions in the pore system on frostresistance. It is a very important point to clarify in order to obtain more basic understanding, and it should be pursued.

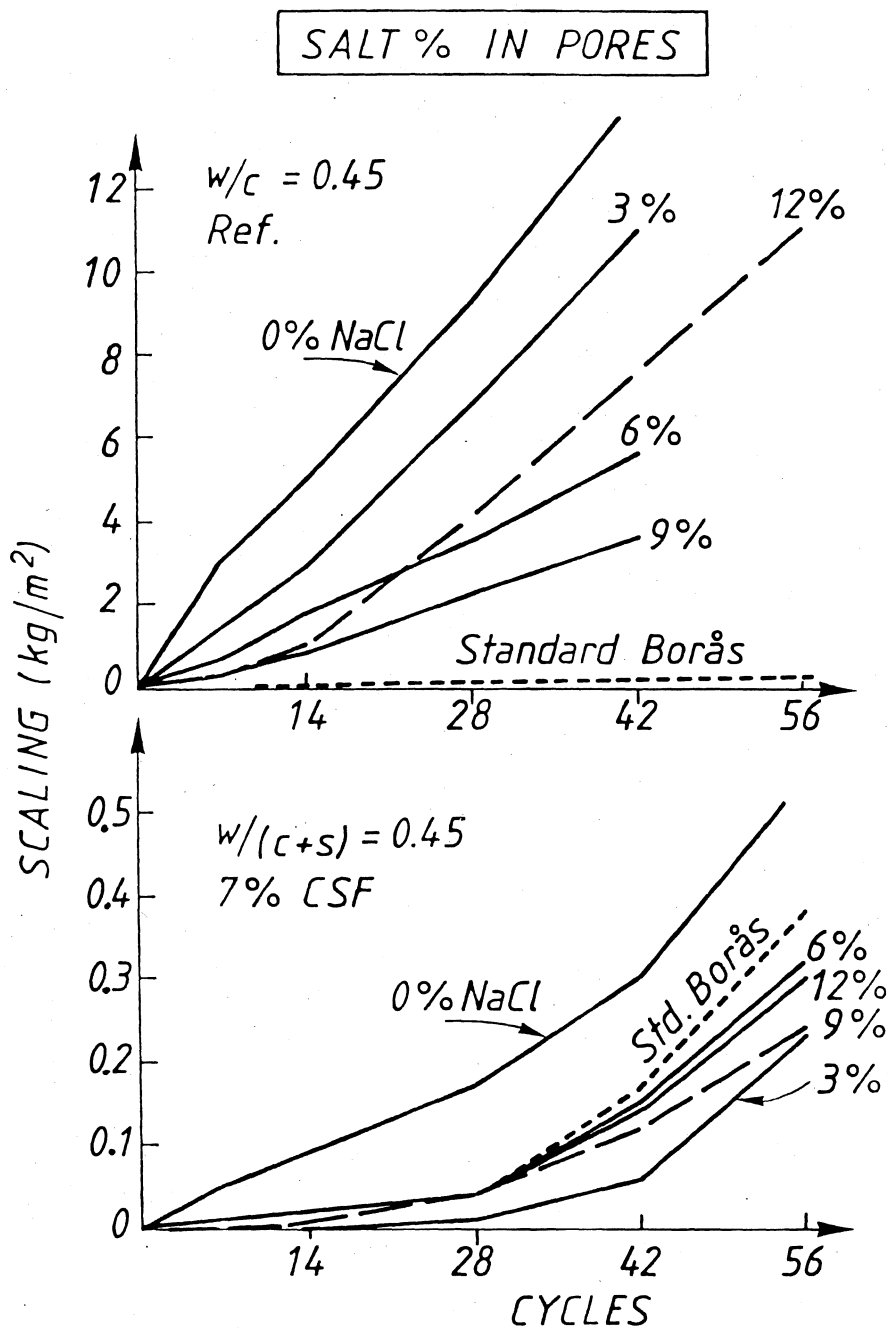

Fig. 7 Scaling for concretes with different salt solutions in the pores. The test surface salt concentration was always 3 % NaCl

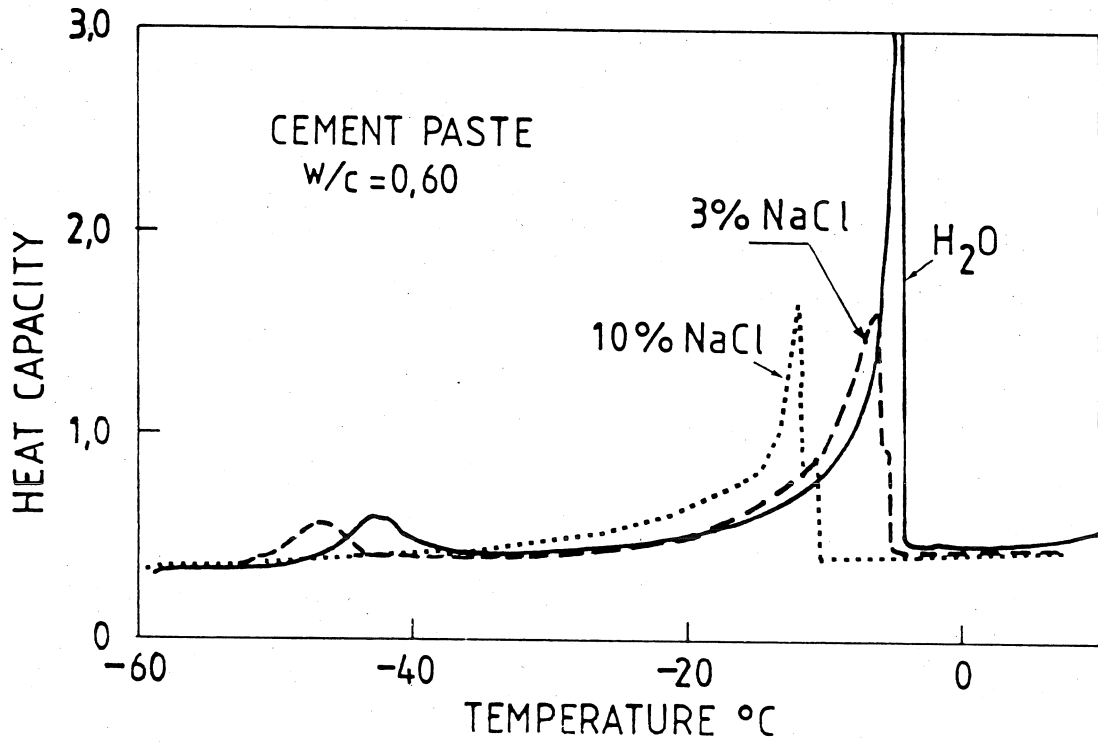

Fig. 8 Freezing calorimetry for pastes dried and resaturated with water or saltsolutions

4. EFFECTS OF CONCRETE COMPOSITION

It has already been pointed out that w/c-ratio, strength and air pore structure are not sufficient to evaluate the potential scaling resistance of concrete. Temperature and moisture histories also play important roles.

4.1 Effect of silica fume at normal strength levels

The effect of silica fume on frost resistance has been a controversial topic in recent years (5). Several concrete "pairs" with 7 to 10 % of the cement replaced by silica fume on a 1:1 basis were tested in this project, f.ex. B17 - B18 (Fig. 5), B19-B20 (Fig. 7). Both examples shows lower scaling for concrete with silica fume. Fig. 5 shows a small reduction for concretes tested without drying/restauration treatment, while after such treatment the difference is more marked, Fig. 7. Other test series gave similar results (3). We conclude that silica fume improves scaling resistance, and, in particular, that the robustness of concrete to elevated temperature curing and drying/restauration treatment is increased when cement is replaced by silica fume a 1:1 basis.

4.2 High strength concrete with and without air

A relevant question today is whether high strength concrete needs air entrainment to be scaling resistant. 7 high strength concretes (> 65 MPa) were tested in this program, 2 of them with air entrainment. The "pair" B8-B9 $w/c+s = 0.35$, $s/c+s = 0.1$ and 0 was not air entrained. The scaling for B8-B9 measured at two laboratories is shown in Fig. 9. B8 with silica fume shows the highest scaling, but the scaling level for both concretes is fairly low, note the ACCEPTABLE limit line. B8 shows some acceleration in scaling beyond the standard 56 cycles, but not a dramatic disintegration as reported earlier for a high strength concrete containing 19 % silica fume (9). A new batch of B8 was produced and tested for 290 cycles after drying/restauration treatment. The scaling was lower than for the original B8 in spite of the pre-treatment, and the Borås-rating was VERY GOOD.

Two air entrained concretes with silica fume B6 and B7 ($w/c+s = 0.35$, $s/c+s = 0.07$, 74 MPa - 3.8 % air, 66 MPa - 5.9 % air) were both rated VERY GOOD after standard Borås-testing; B7 also after drying/restauration treatment. This in spite of rather poor values for the spacing factors of 0.40 and 0.26 mm, respectively.

Fig. 6 shows scaling for two high strength concretes with P30-4A offshore cement, both dried/resaturated before testing. The concrete with the lowest strength (H5, 91.5 MPa) shows scaling on the level of B8 with silica fume (Fig. 9) with a certain acceleration beyond 100 cycles. The concrete with highest strength (H7, 115 MPa) shows minimal scaling regardless of saltconcentration up to 140 cycles.

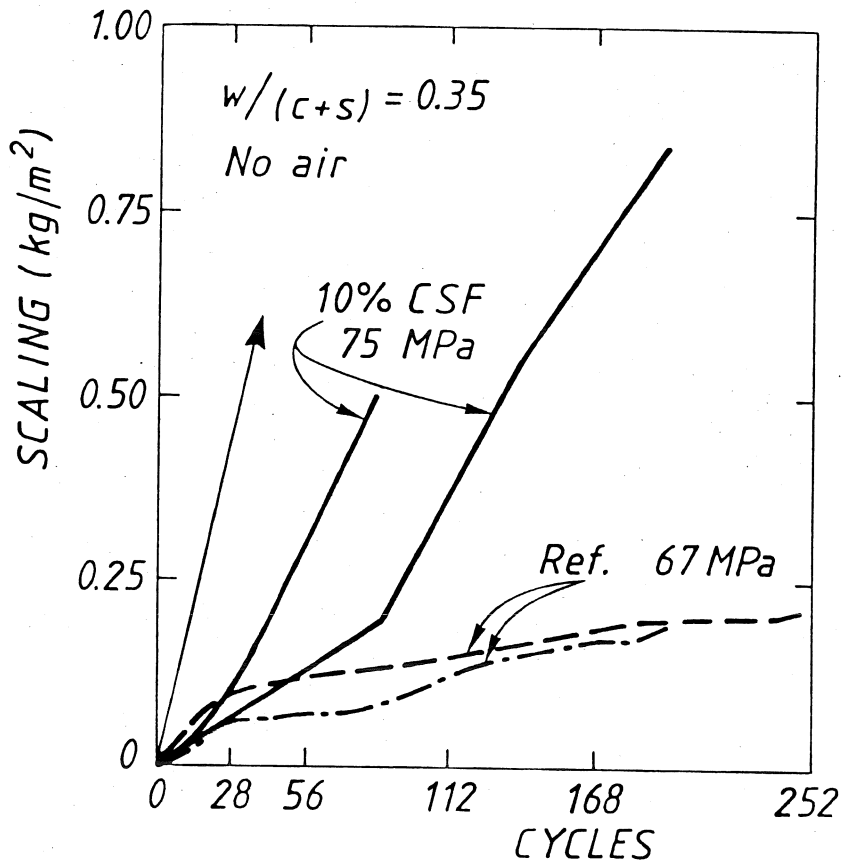

Fig. 9 Scaling of two high strength concretes, each tested at two laboratories

These results as a whole indicate that high strength concrete does not need airentrainment to be salt/frostresistant according to the Borås-method, even including a drying/restaturation treatment and extension of the number of freeze/thaw-cycles well beyond the standard 56. With sufficiently low $w/c+s$ -ratio the rating VERY GOOD may be obtained. The limit appears to be around $w/c+s = 0,30$, but probably depends both on cement type and silica fume dosage. Silica fume appears to cause some acceleration in the scaling beyond the standard 56 cycles for concrete with $w/c+s$ -ratio of 0,35. High strength concrete is much more robust to drying/resaturation treatment than normal concrete. Recent data indicated robustness of high strength concrete also to elevated temperature curing: concrete with $w/c+s = 0,30$ and $s/c+s = 0.08$ showed minimal scaling when cured at 60°C and dried/resaturated before scaling tests (10).

5 FINAL REMARKS

The Borås-method is judged well suited to rate the salt/frost-resistance of concrete. We believe the method gives the potential resistance for a given concrete composition when it is homogeneous and cured under well controlled conditions. For field concrete the homogeneity, as well as the entire temperature/moisture-history plays important roles. The present results demonstrate that scaling can increase dramatically with relatively moderate changes in these factors, particularly the drying/resaturation treatment and elevated temperature curing. Neither are unrealistic relative to natural exposure conditions. The practical use of the Borås-method in the standard version is considered tough but reasonably realistic in that concrete of reasonable w/c-ratio and air pore structures fulfill the criteria. As seen above this is not true after dry/resaturation or curing at 60°C. Similarly, cases exist where cores taken from old concrete with good field performance shows very high scaling when tested in the laboratory. Thus, we can say today that the Borås-method is very useful in rating concrete composition with well controlled temperature/moisture - histories. It appears to be too tough when the concrete pre-test treatment is other than standard laboratory procedure. The present observation that several high strength concretes without air entrainment meet the Borås criteria even after curing at 60°C and drying/resaturation treatment indicates to the author that such concretes will perform well in severe field exposure.

6. ACKNOWLEDGEMENT

Many researchers at the 5 laboratories were involved in the planning and execution of the project. The enthusiastic cooperation and inspiring discussions during the work is gratefully acknowledged.

The work has been carried out as part of the larger project: "BETONGENS FUNKSJONSDYKTIGHET", supported by The Royal Norwegian Council for Scientific and Industrial Research and a number of industry partners. NORCEM A/S was the project manager.

7. REFERENCES

- /1/ "Beton og frost", Nordisk Workshop, Køge 1984. Dansk Betonforening "Publikasjon Nr. 22, København 1985
- /2/ Sellevold, E.J., "Betongens funksjonsdyktighet, Delrapport nr 26, Frostbestandighet: Ringforsøk - Salt/Frost Avskalling", STF65 A88089, 1987, Trondheim
- /3/ Sellevold, E.J., "Betongens funksjonsdyktighet, Delrapport nr 27, Frostbestandighet: Salt/frostavskalling, Effekt av prøvebetingelser og betongsammensetning", STF65 A88090, 1988, Trondheim
- /4/ Bager, D.H. og Sellevold, E.J., "Ice Formation in Hardened Cement Paste, Part II - Drying and Resaturation of Room Temperature Cured Pastes". Cement and Concrete Research, Vol 16, pp. 835-44, 1986
- /5/ FIP State-of-the-art report: "Condensed Silica Fume in Concrete", Main author E.J. Sellevold, Thomas Telford, London, 1988
- /6/ Villadsen, J., "Hærdetemperaturens indflydelse på Hærdnet Cementpastas Porestruktur", Lab.f.Bygn.Mat., Danmarks tekniske Høyskole, 1989
- /7/ Jacobsen, S., "Innvirkning av betongens herdetemperatur på frostbestandighet etter SS137244", Report 02891, Norges Byggforskningsinstitutt, Oslo, Des. 1990
- /8/ Sellevold, E.J., "Betongens Funksjonsdyktighet, Delrapport nr 28, Frostbestandighet. Isdannelse i herdnet sement pasta med saltløsning i poresystemet", STF65 A88091, 1988, Trondheim
- /9/ Petersson, P.E., "The Influence of Silica Fume on the Salt-Frost Resistance of Concrete". Proceedings International Seminar, Chalmers Univ. Tech., Gøteborg, April 1986. Publication DI: 1988, Swedish Council for Building Research
- /10/ Jacobsen, S. and Sellevold, E.J. Unpublished results

**SCALING RESISTANCE OF CONCRETE. TESTING ACCORDING TO
SS 13 72 44**

Per-Erik Petersson

**Swedish National Testing and Research Institute
Borås, Sweden**

Scaling resistance of concrete. Testing according to SS 13 72 44. Presentation at the RILEM seminar in Lund, 17-18th June 1991.

*Per-Erik Petersson
Swedish National Testing and Research Institute
Borås, Sweden*

1 Introduction

A suitable method for testing the scaling resistance of concrete must fulfil a number of requirements.

- +The method must be realistic which means that the type of failure must be the same as the one taking place in a real structure and it must be possible to transform the test result to some form of prediction of the service life.

- +The method must be reproducible which means that the test result for a defined concrete must be the same for tests performed at different times and in different laboratories.

- +The method ought to be simple and cheap so it can be carried out not only in advanced concrete laboratories but also in ordinary factory laboratories.

The method also ought to be useful for different purposes: to study the influence of the constituents such as cement, additions, admixtures etc on the scaling resistance, to study the influence of curing, to perform pretesting of concrete as well as performance tests on drilled cores from real structures and so on.

The Swedish standard test method for assessing the scaling resistance more or less seems to fulfil these requirements.

2 The test method (SS 13 72 44)

The method is presented in figure 1. A rubber membrane is glued on all surfaces but the test surface of the 50 mm thick specimen. A 3 mm thick layer of salt solution is poured on the test surface. A 3 % sodium chloride solution is normally used but other solutions and water can be used as well.

The solution is covered with a plastic foil in order to prevent evaporation which can change the concentration of the solution. This is very important since only a small change of the concentration may influence the test result considerably /1/.

A 20 mm heat insulation is attached to all the sides but the test surface. The bottom insulation makes the heat transport take place mainly through the test surface, which is a situation

similar to that normally happening in a real structure. Without the bottom insulation the test surface would be the warmest part of the specimen during the cooling phase!

The heat insulation on the sides also makes the temperature distributing uniform over the test surface and the heat transport becomes more or less one-dimensional. Without the heat insulation the scaling normally becomes most severe at the edges of the test surface which affects the test result and makes the result dependent on the dimensions of the specimen. With the insulation this effect disappears and the results from 50 mm thick specimens with different dimensions can be compared. For example, slices from 150 mm cubes can be tested as well as 100 mm drilled cylinders and the results become comparable!

The temperature is measured by thermo-couples or some other equipment. In order to obtain a well defined temperature cycle the temperature is registered in the salt solution.

Each freeze-thaw-cycle lasts 24 hours and the temperature varies between -18 - +20 C and the temperature must fall within the shaded area in figure 2. The testing normally continues until 56 cycles.

So far most tests have been carried out on sawn surfaces on slices taken from 150 mm cubes. The sawn surface then is located vertically in the centre of the cube according to figure 3. This type of specimen is suitable for testing the potential scaling resistance of concrete and also the influence of the constituents on the resistance

Sometimes it is more interesting to study the properties of the cast surface of a specimen, for example when studying the influence of the curing conditions and then procedure II in figure 4 is preferable.

Procedures III and IV can be used for cylinders drilled from structures.

Of course it is possible to choose other dimensions of the specimens but the thickness must always be about 50 mm.

The tests are performed in standard freezers which are equipped with a heater for the thawing phase and fans in order to guarantee good circulation of the air. The temperature is normally measured for one specimen in each freezer.

After 7, 14, 28, 42 and 56 cycles the material spalled is collected, dried and the loss of mass is measured. The value after 56 cycles represents the test result.

The tests are normally carried out on 4 specimens with a test surface of 15 times 15 cm. So far the method mainly has been used for concrete used for bridges in Sweden and then these requirements have been chosen .

- | | |
|------------|--|
| -Very good | No specimen has more than 0.1 kg/m ² material scaled after 56 cycles |
| -Good | The scaling (mean value) after 56 cycles (m_{56}) is less than 0.5 kg/m ² and m_{56}/m_{28} is less than 2. |

- Acceptable m_{56} is less than 1.0 kg/m² and m_{56}/m_{28} is less than 2.
- Not acceptable The requirements for acceptable scaling resistance are not met.

When pretesting concrete for bridges the requirement is good scaling resistance while acceptable scaling resistance is required for drilled cores from bridges and for testing concrete taken at the building site.

3 Test results

3.1 Introduction

Five years ago it was difficult to produce concrete with good scaling resistance in Sweden, i.e. concrete that fulfilled the requirement for acceptable scaling resistance according to the Swedish standard test method. The scaling resistance was poor also for high air contents of 6-7 % and low water-cement-ratios of 0.45. In order to find out the reason for the poor resistance some research projects were carried out and I will give a short presentation of the results from some of these projects.

3.2 The influence of air entraining agents (AEA) and plasticizers on the scaling resistance

In a project /2/ two air-entraining agents, AEA1 and AEA2, were used as well as a combination of an AEA and a plasticizer, AEA1+PL. The admixtures were of the following types:

- AEA1: a mixture of neutralized Vinsol Resin+synthetic tenside
- AEA2: neutralized Vinsol Resin
- PL: a melamine-based plasticizing agent

The test results are presented in figure 5. Each line represents the mean value for 4 specimens.

For concrete with AEA1 as the only admixture, the amount of spalled material is small for air contents exceeding about 4 %. When the air content is as low as 3 % the concrete also has an acceptable salt-frost resistance according to SS 13 72 44. For concrete with AEA2 as the air entraining agent the scaling resistance is also good for air contents exceeding about 4 % while the resistance seems to be poor for an air content of 3 %.

The spalling values are high for the combination of AEA and plasticizer used. Not even when the air content is as high as 6 % is the requirement for an acceptable salt-frost resistance according to SS 13 72 44 fulfilled.

In the investigation only a few of existing admixtures for concrete have been studied. In spite of this limitation the results clearly imply that concrete with a good AEA as the only admixture has better and more stable salt-frost resistance than if the AEA is combined with a plasticizer. Other combinations may give rise to other results but one must always be aware

of the difficulties of producing concrete with good and stable scaling resistance when plasticizing agents are used.

3.3 The influence of the cement on the scaling resistance

In another project /3/ the influence of the cement on the scaling resistance was investigated. Two of the curves in figure 6 represent the most commonly used OPC in Sweden (Slite std). The C_3A -content is about 9 % and the alkali content about 1.1 % (eq NaO). The other two curves also represent an OPC (Degerhamn std) but this is a SR-cement with a low alkali-content of about 0.6 % and a C_3A content of about 2 %. The cement also has a low value of the heat of hydration. The composition of the two cements are presented in figure 7.

For each cement two AEAs has been tested but there does not seem to be any significant difference between the two admixtures.

The axes represent the scaling and the air content respectively. The two cements give concrete with very different scaling resistance. With OPC Degerhamn, the cement with the low content of alkali, good scaling resistance is reached with an air content of 4 %. With OPC Slite, the other cement used, an air content of 6 % is not sufficient to get comparable frost resistance. The results indicate that the choice of cement is an important factor to be aware of when producing concrete with good scaling resistance. Also different types of Portland cements may produce concrete with completely different scaling resistance.

3.4 The influence of the curing temperature on the scaling resistance

According to our experience the Swedish standard test method seems to work but still there are a few questions that must get an answer. One is to find out the most relevant way of treating the specimen before testing.

In figure 8 results from a Norwegian investigation /4/ are presented. Two different concretes, one without and one with silica fume have been stored at two different temperatures, +20 and + 60 C directly after casting. The concretes were not air-entrained. The specimens were stored in water at these temperatures during the first 7 days and then in water at +20 C during 21 days before the start of the scaling test.

As can be seen in the figure the scaling increases strongly with increasing temperature during the initial curing. The scaling increases three times for the concrete without silica fume. For the concrete with silica fume the scaling is lower but the increase more severe and is almost 10 times.

When evaluating the scaling resistance from standardized tests, this is an effect one must be aware of.

In figure 9 results are presented for specimens which have been cured slightly different before the test /3/. Results for two concrete qualities produced with different types of OPC are presented.

The normal curing means that the concrete is stored at 20 C all the time until testing at 28 days, the first 7 days in water and then in air. The other curing method means that the concrete was identically stored with the exception that it during two days, the 21st and 22nd after casting were stored in air with the temperature of +50 C. As can be seen, the higher temperature, and thus the stronger drying, results in a much higher scaling. The test results seem to be extremely sensitive to the treatment before testing and one must be aware of this fact when evaluating the test results

3.5 Scaling resistance of concrete for bridges in Sweden

As mentioned before it was difficult to produce concrete with good scaling resistance in Sweden only a few years ago. Today the situation has changed completely. There are a number of explanations for this. First of all the producers have realised the importance of using the best cements and the best admixtures when producing concrete for structures exposed to severe environmental conditions. Another important factor is that the Swedish National Road Administration since 1988 requires that all concrete intended for bridges must be pretested with respect to the salt frost resistance. The results for the pretests carried out at our institute during 1990 are presented in figure 10. Each point represents the mean value of four specimens.

According to the test results most of the concretes have an excellent scaling resistance, less than 0.1 kg/m². The SR + LA cement (Degerhamn) shows the best results and all tests fulfil the requirement for the pretest, i.e. 0.5 kg/m². The Slite cement with a higher alkali content (compare figure 7) shows higher scaling and some of the values do not fulfil the requirement.

The results show that normally it is no problem to produce concrete with good scaling resistance. The results also clearly indicate the importance the type of cement has on the salt-frost resistance.

4 Field exposure tests

A test method is useful only if there exists a correlation between the test result and the expected service life for the structure. From experience we have a good knowledge of this correlation for normally used concrete qualities but we ought to learn much more, especially where new types of binders and concretes are concerned. For this reason we started field exposure tests last autumn. Three field exposure stations are established: One in the area of our institute, one along the highway between Gothenburg and Borås which is heavily deiced each winter season and finally one station in the splash zone at the Swedish west coast. Concretes with water-cement ratios varying between 0.3 and 0.9 and air contents between 0 and 6 % are placed at the different field stations and parallel tests of course are carried out according to the Swedish test method.

Already after the first, very mild winter the poorest qualities show severe damages. According to the test results available so far it seems as the exposure along the highway is the most severe.

A preliminary report is under preparation but I think we have to wait another one or two years before it is time to make any essential conclusions.

5 References

- /1/ Verbeck, G.J.
Klieger, P Studies of salt scaling of concrete. Highway research board. Bulletin 150, 1957.
- /2/ Petersson, P.E. The use of air-entraining and plasticizing admixtures for producing concrete with good salt-frost resistance. Swedish National Testing and Research Institute, Report 1989:37, Borås 1989.
- /3/ Malmström, K The importance of cement composition on the salt-frost resistance of concrete. Swedish National Testing and Research Institute, Report 1990:07, Borås 1990 (in Swedish).
- /4/ Jacobsen, S The influence of the curing temperature on the scaling resistance of concrete tested according to SS 13 72 44. Report Nordtest project 820-89, Norwegian Building Research Institute (NBI), Oslo 1990 (in Norwegian).

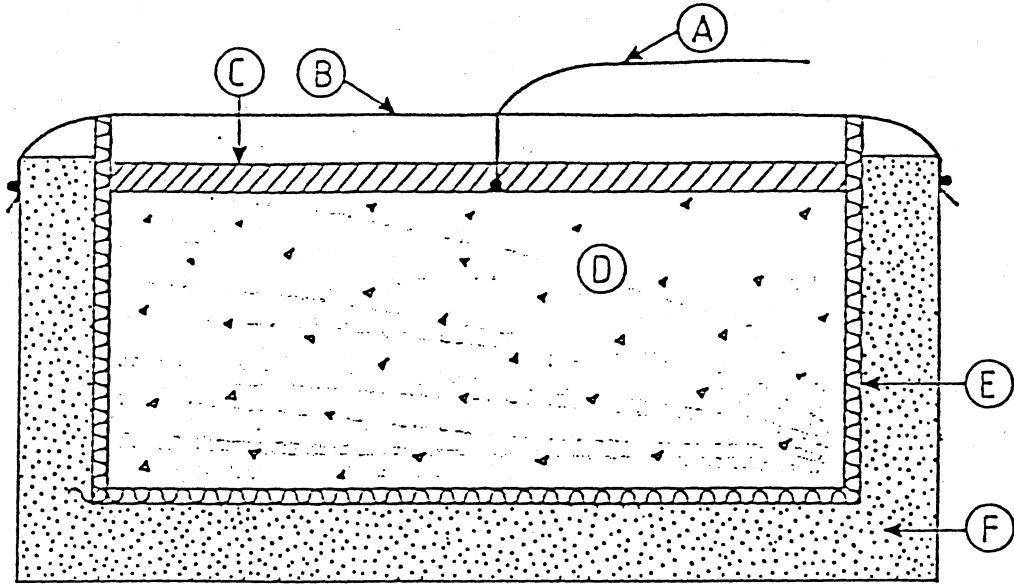

FIGURE 1: The test equipment used for the scaling resistance test according to SS 13 72 44. A=Thermocouple, B=plastic foil, C=salt solution, D=specimen, E=rubber membrane, F=heat insulation.

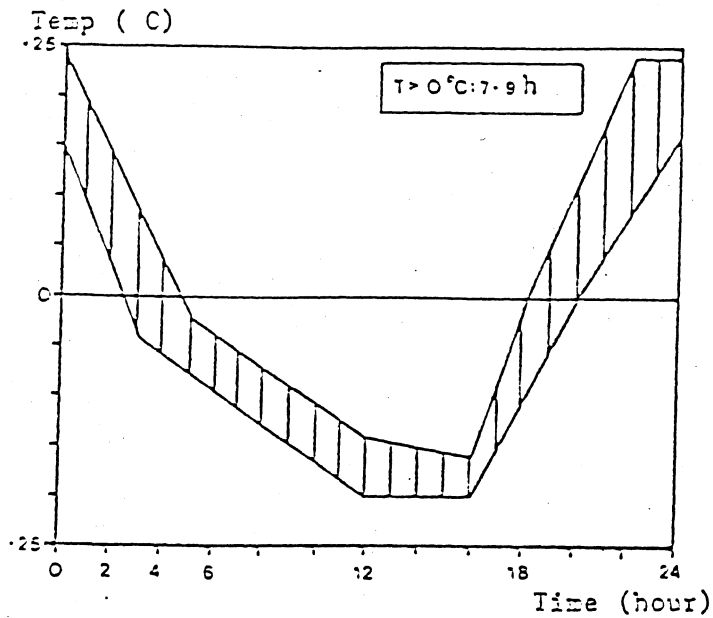

FIGURE 2: The temperature cycle must be within the shaded area in the diagram.

PROCEDURE I

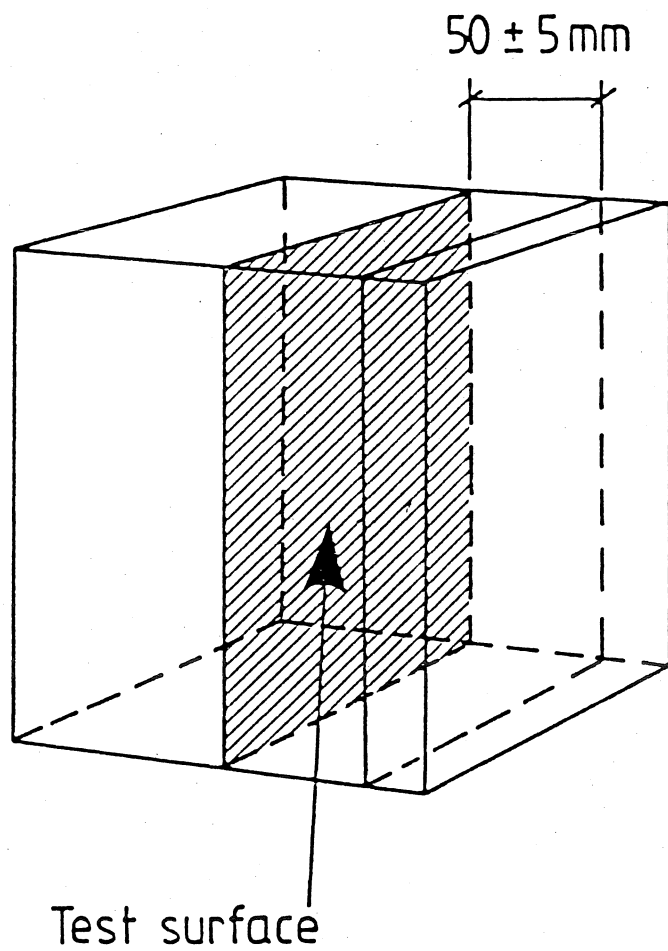
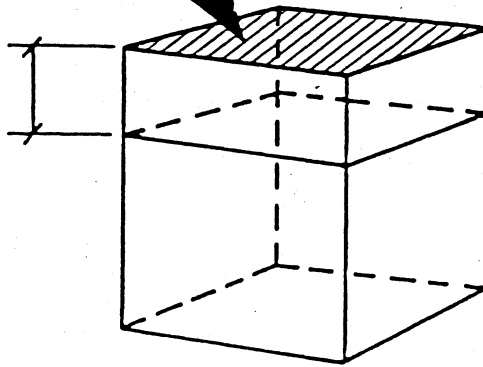

FIGURE 3: Procedure I means that the test surface is located vertically in the centre of a cube.

Test surface

Procedure

50 ± 5



II

Test surface

20

50 ± 5

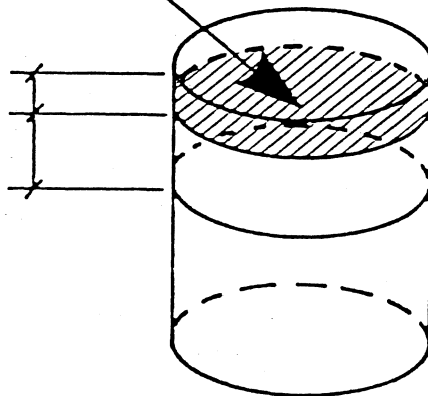

III

Test surface

50 ± 5

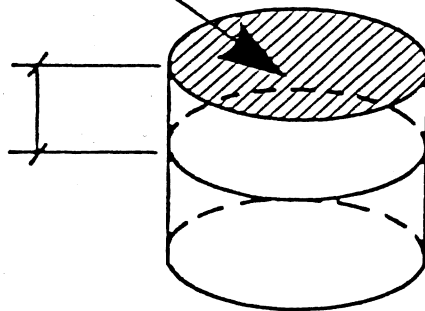

IV

FIGURE 4: Procedure II, III and IV means other types of specimens.

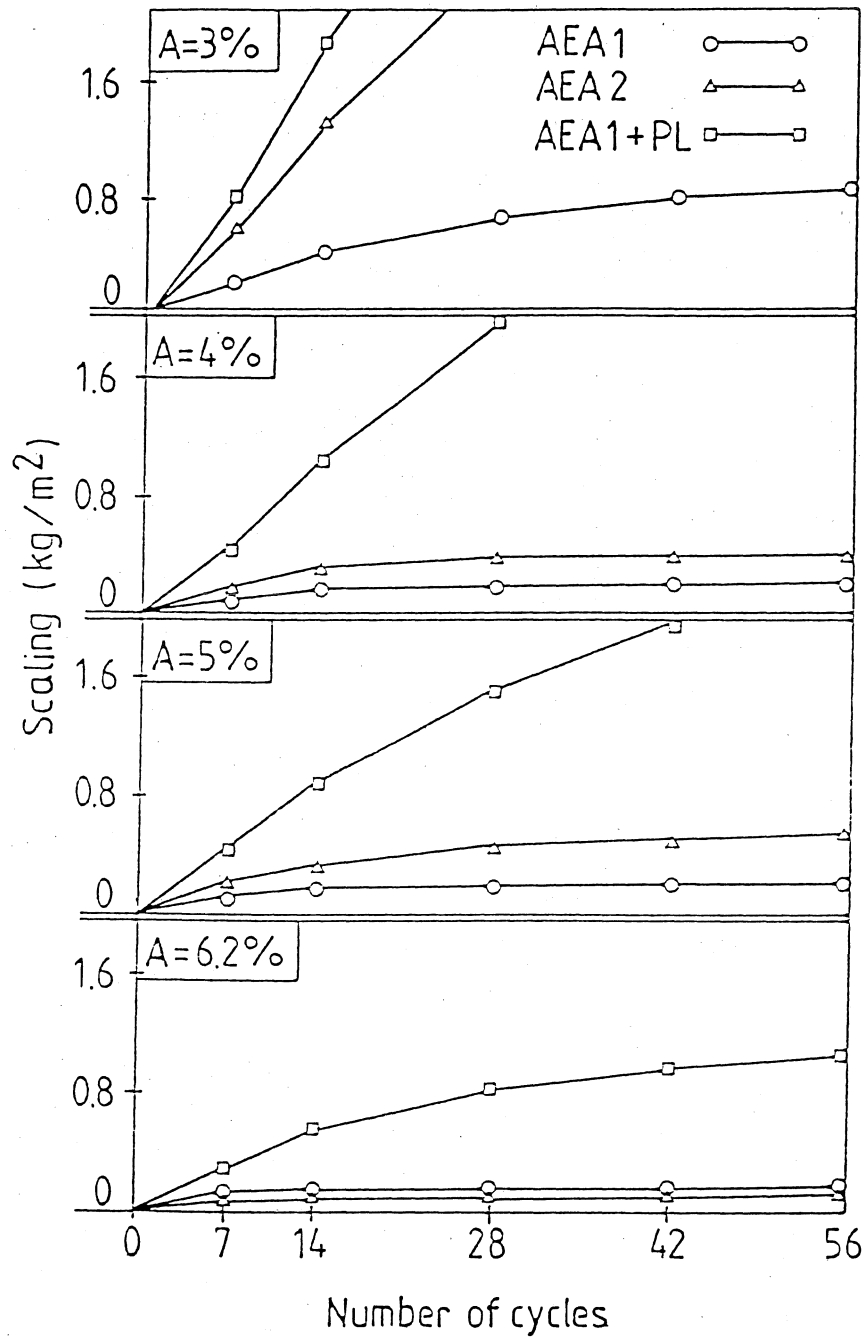

FIGURE 5: The amount of scaling vs the number of freeze-thaw cycles for different air contents and different admixtures (AEA=air-entraining agent, PL=plasticizer).

INFLUENCE OF THE CEMENT ON THE SCALING RESISTANCE

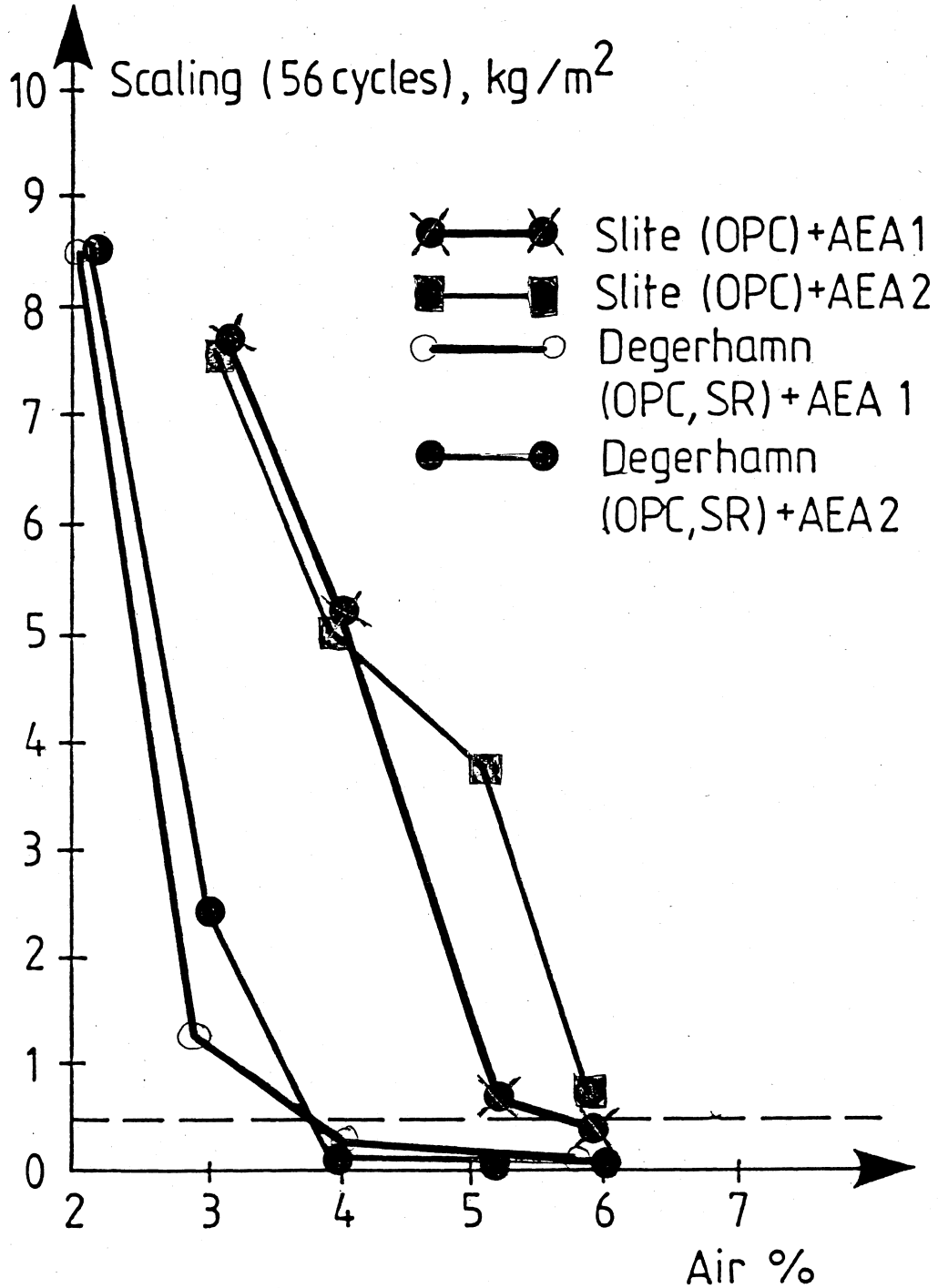

FIGURE 6: Scaling after 56 cycles for varying air contents for two OPC (Slite and Degerhamn). The cements are characterized in figure 7. C88L and Aer L are two different air-entraining agents .

Constituent	OPC-Slite (% by weight)	OPC-Degerhamn (% by weight)
SiO ₂	20.4	22.6
TiO ₂	0.24	0.20
Fe ₂ O ₃	2.16	4.29
Al ₂ O ₃	4.58	3.41
MnO	0.06	0.22
CaO	63.9	66.3
MgO	3.16	1.19
Na ₂ O	0.25	0.13
K ₂ O	1.28	0.70
SO ₃	3.4	2.4
LOI	2.6	1.1
Cl	<0.01	<0.01
C ₃ S	61.2	62.4
C ₂ S	12.3	17.7
C ₃ A	8.5	1.8
C ₄ AF	6.6	13.1

FIGURE 7: Composition of the two cements OPC-Slite and OPC-Degerhamn.

BINDER	CURING TEMP (°C)		SCALING (kg/m ²) 28 cycl
	IN WATER		
	Day 1-7	Day 8-28	
OPC W/C=0.45	+20	+20	5.9
	<u>+60</u>	+20	15.3
OPC+ silica (8%) W/C+S=0.45	+20	+20	0.9
	<u>+60</u>	+20	8.6

FIGURE 8: Influence of curing temperature during the first 7 days on the scaling resistance of concrete according to Jacobsen /4/.

BIN- DER	CURING TEMP (°C)				SCALING 56 cycles (kg/m ²)
	Age, days				
	01-07 W	08-20 A	21-22 A	23-28 A	
OPC, SLITE W/C=0.45 Air 6 %	+20	+20	+20	+20	0.6
	+20	+20	<u>+50</u>	+20	10.0
OPC (SR), DEGERH W/C=0.45 Air 6 %	+20	+20	+20	+20	0.1
	+20	+20	<u>+50</u>	+20	5.2

FIGURE 9: Influence of curing conditions on the scaling resistance of concrete according to Malmström /3/.

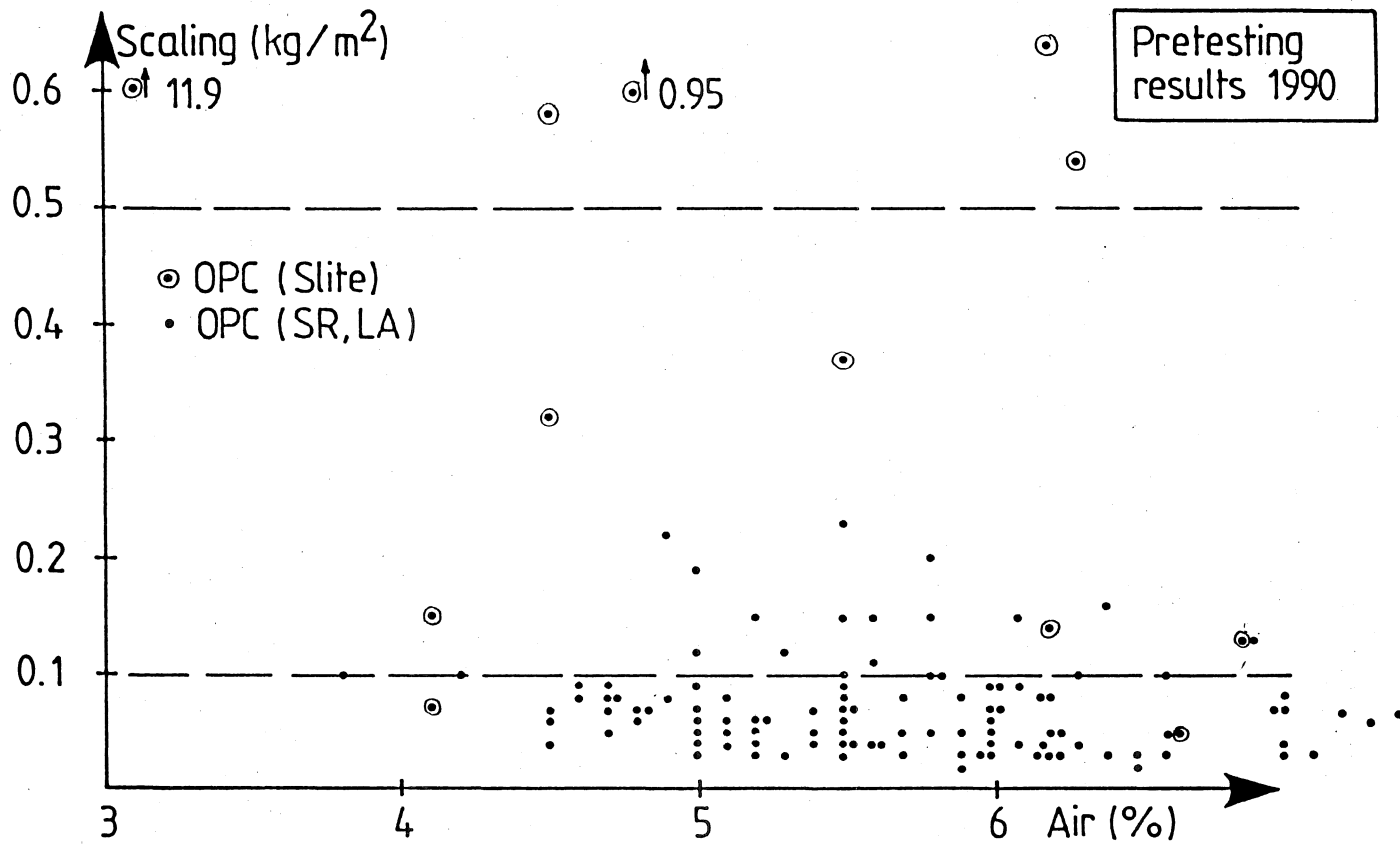

FIGURE 10: The pretest results for bridge concrete for tests carried out at SP during 1990. The characteristics for the two cements OPC(Slite) and OPC(SR,LA)=OPC(Degerhamn) are shown in figure 7.

FREEZE/THAW TYPE APPROVAL TESTING

T.A. Harrison

**British Cement Association
Wexham Springs, Slough, England**

and

R. Sym

Consultant,

**RILEM TC 117: Workshop on freeze/thaw
testing with de-icing salts**

FREEZE/THAW TYPE APPROVAL TESTING

by

T A Harrison
BSc., PhD C. Eng., MICE, FICT.
Standards Manager, British Cement Association

and

R Sym
BSc., PhD
Consultant Statistician

SUMMARY

A satisfactory freeze/thaw type approval test appears to require several hundred samples to be tested. This creates practical problems and a potential solution is to pre-select those samples which will perform least well in freeze/thaw by, for example, dry density or 24 hour water absorption and then test just those few samples.

INTRODUCTION

The development of a free market in Europe for goods and services has a consequence that products including those made of concrete should be certificated. Whilst the details are still being developed, the concept of initial approval tests (type approval) followed by routine testing is established as a framework.

Due to the length of time needed and the cost, the freeze/thaw performance may be assessed at the 'type approval' stage and not during routine testing. This, in effect, means that there is only one opportunity to classify a product and therefore the type approval test must satisfy the following criteria:

1. it correctly classifies a product;
2. different certification bodies would reach the same conclusion;
3. the selected test and specification limits are correlated with performance in practice.

Our winters are not standard and good performance over a few years may be due to mild winters and not the potential freeze/thaw resistance of the product. It is reasonable to require a product to survive a bad winter in its first year of exposure and therefore the correlation with performance needs to be made on this basis.

DESIGN OF TYPE APPROVAL TESTS

The freeze/thaw performance of a product may not be normally distributed, Figure 1, and therefore basing the approach on inspection by attributes⁽¹⁾ is an appropriate method to select. This requires an agreement on the level of failures that is acceptable. For concrete strength, we often use the characteristic value which implies 5% failures. This level of failures applied to, for example, 200mm x 100mm paving blocks would imply failures of 2½ blocks per m² which is a value which few consumers would find acceptable.

Figure 1: Freeze/thaw test data for Mix 22

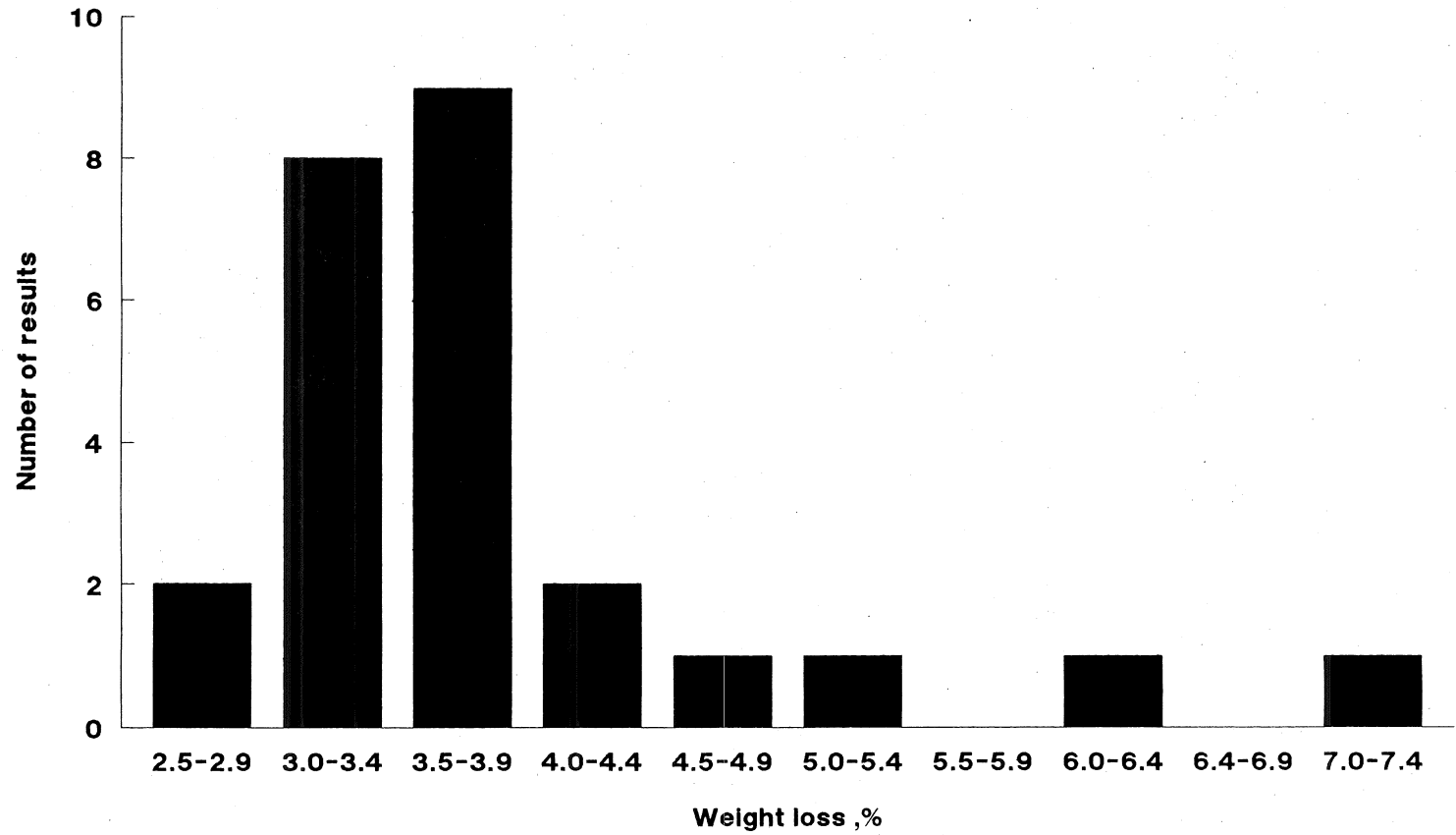

All blocks were tested at the same time.

The establishment of the appropriate level of failures is a matter for consumers and producers to agree and then the agreed value should be specified in the appropriate product standard.

When the decision about the quality of a product is to be based on tests on a sample of the product, both consumers and producers face risks. In respect of type approval testing, the consumer's risk is that of the product being classified as acceptable, when in reality the product contains an unacceptably high proportion of defectives. The producer's risk is that of having a product with an acceptable number of defectives rejected by the type approval test. Operating - characteristic curves are used to display the relative risks to consumers and producers.

The perfect O-C curve, Figure 2, is one where there is a 100% probability of rejecting a product with more defectives than the acceptable quality level (AQL) and a 100% probability of accepting a product with an acceptable quality level. Such curves do not exist in practice and a typical O-C curve is shown in Figure 3. With realistic curves, there is a finite risk of accepting a product containing an unacceptable percentage of defectives, and also a finite risk of rejecting a product containing an acceptable percentage of defectives. By fixing the customer's risk and the producer's risk, the O-C curve information can be presented in a tabular form and Table 1 is an example.

The design of the type approval test thus requires agreement on what the consumer's and producer's risks should be. Once these have been chosen, the sample size and the acceptable criterion that give these risks can be obtained from tables given in ISO 2859. (Ref. 1)

A type approval test is a one-off event, so it is important that a product which the consumer regards as unsatisfactory will have a low probability of acceptance. For the sampling plans given in Table 1, the product qualities that have a low probability of acceptance are given in the consumer's risk column. It can be seen that these product qualities range from 3.1% defectives (with a sample size of 125) to 0.8% defectives (with a sample size of 500).

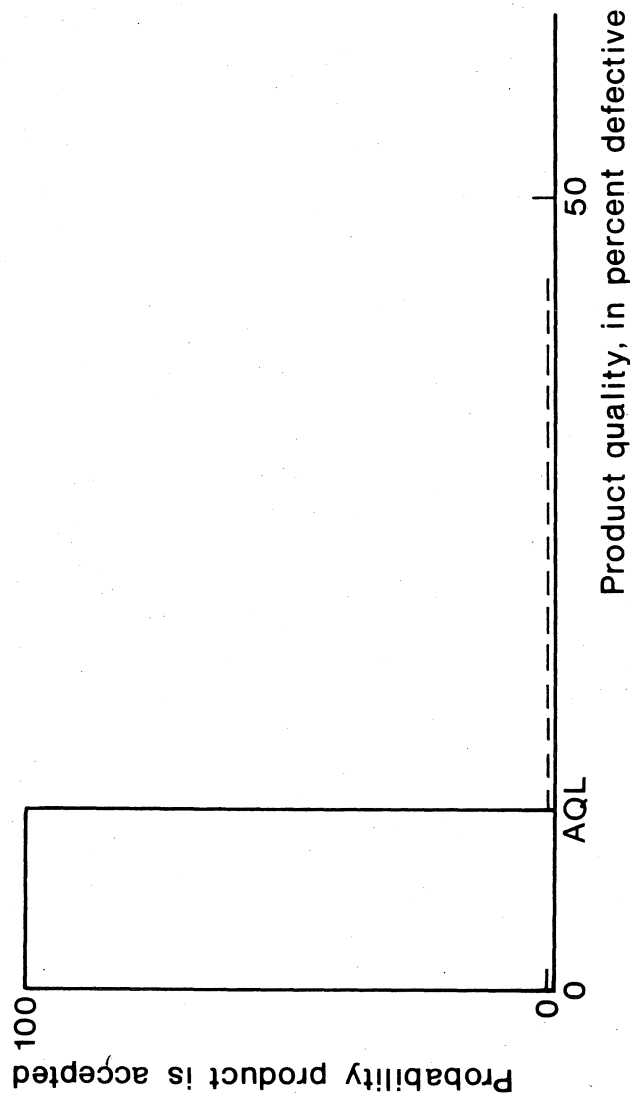

FIGURE 2. A PERFECT OPERATING CHARACTERISTIC

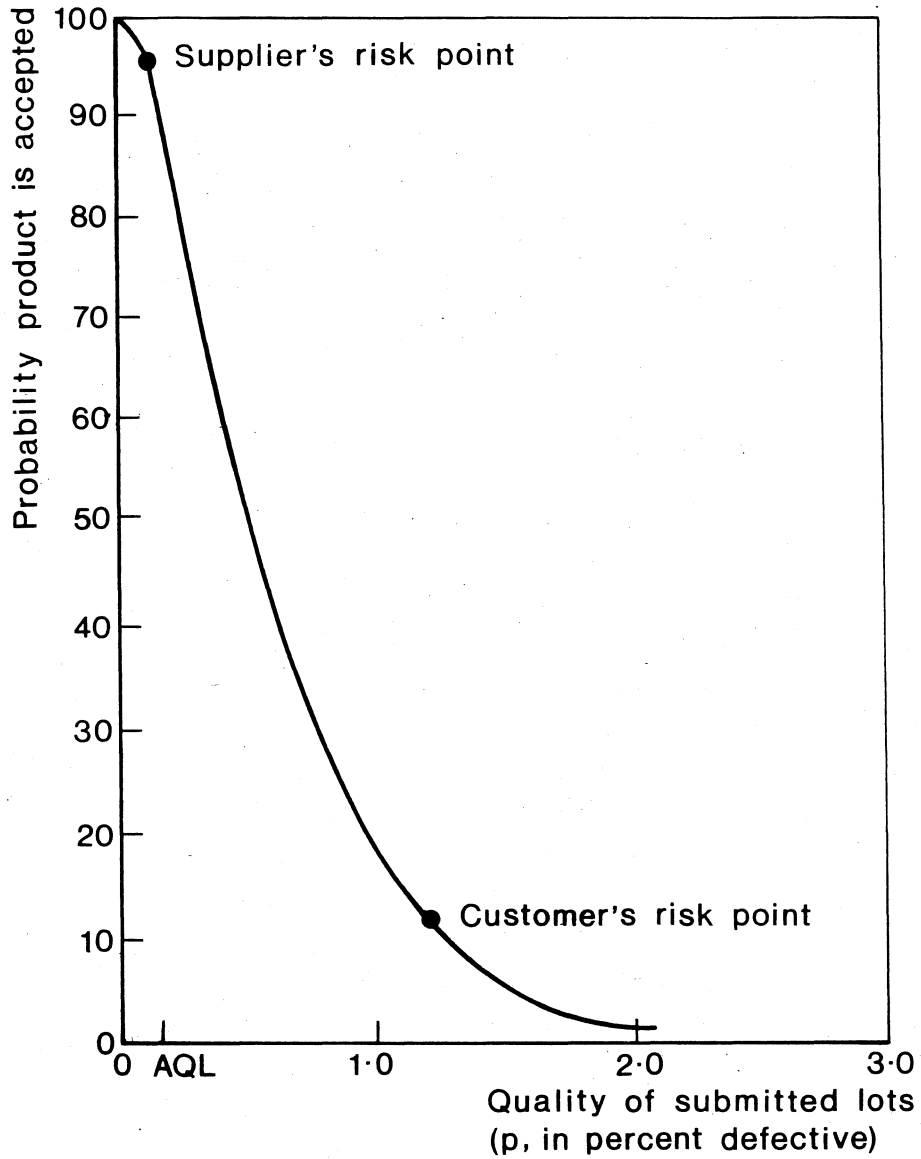

FIGURE 3. OPERATING CHARACTERISTIC CURVE FOR A SAMPLING PLAN, WITH SAMPLE SIZE $N = 315$ AND REJECTION NUMBER 2

Table 1: Percentage defectives in the production for a producer's risk of 5% and a consumer's risk of 10% for type approval testing with a rejection number of 2 (Ref. 1)

Sample size N	Acceptance number	Rejection number	Percentage defectives in the production	
			Consumer's risk Pa = 10%	Producer's risk Pr = 5%
125	1	2	3.1	0.3
200	1	2	1.9	0.2
315	1	2	1.2	0.1
500	1	2	0.8	0.07

Notes

Pa = probability product is accepted
 Pr = probability product is rejected
 N = number of specimens tested

Acceptance number = 1 means that the product is accepted if no more than 1 specimen fails the test

Rejection number = 2 means that the product is rejected if 2 or more specimens fail the test.

If the consumers propose that the level of failures should not be more than about 1% which, for example, translates to a failure level of one paving block per 2m², the sampling plan in Table 1 with a sample size of 315 has acceptable properties from the consumer's point of view.

The right hand column in Table 1 gives the producer's risks, i.e. it shows the product quality (in percent defective) that the producer has to achieve to have a low probability of rejection. It will be seen that the percent defectives in the producer's risk column of Table 1 are much smaller than the percent defectives in the consumer's risk column, for all the sampling plans in the table. For the sampling plan with a sample size of 315, the product should contain no more than 0.1% defectives (1 in 1000) for the producer's risk to be small: this requires the producer to design the product so that it contains only a very small proportion of specimens that might fail the freeze/thaw test.

If these levels of failures are accepted, freeze/thaw tests on 315 to 500 specimens are needed for a type approval test. This will be extremely expensive unless there is some means of selecting from this sample those few specimens that will give the worse performance.

PRE-SELECTION OF SPECIMENS FOR FREEZE/THAW TESTING

If an easily measured parameter can be identified that ranks the freeze/thaw performance of a product, all the large sample N can be assessed and, say, the 10 worse specimens can be selected for freeze/thaw testing. Various parameters may be used for this pre-selection and the best parameter will depend on the actual product. For example, with block paving some initial tests have indicated that dry density or 24 hour water absorption are possible parameters. Further work is in progress to check if this applies to a wider range of mixes.

CONCLUSIONS

1. The number of samples needed for a freeze/thaw type approval test is likely to be several hundred. As it is not practical to test this number of samples, the sample should undergo a pre-selection to identify those products which will perform least well in the freeze/thaw test. Freeze/thaw testing of this small sample can then be used to determine the type approval.
2. A sampling plan that has reasonable statistical properties has an initial sample size of 315 specimens, an acceptance number of 1 and a rejection number of 2. With this plan, a product with 1% defectives has a low probability of being accepted in a type approval test. For the product to have a high probability of acceptance in a type approval test, it must have less than 0.1% defectives.

REFERENCES

- (1) INTERNATIONAL STANDARDS ORGANISATION. Sampling procedures for inspection by attributes. Part 1. Specification for sampling plans indexed by acceptable quality level (AQL) for lot-by-lot inspection. ISO 2859-1: 1989

**EXPERIENCES WITH THE CRITICAL DEGREE OF SATURATION
METHOD TO MEASURE FROST RESISTANCE OF CONCRETE**

Werner Studer

**EMPA
Dübendorf, Switzerland**

Experiences with the critical degree of saturation method to measure frost resistance of concrete

W. Studer, EMPA, Dübendorf, Switzerland

Abstract

At EMPA we started our investigations on the critical degree of saturation method to measure frost resistance of concrete in 1976. Starting from the description by Fagerlund [1], we developed a relatively simple, cheap and effective procedure that provides reliable informations not only on frost-resistance but also on "overall quality" of concrete [2]. The test is approved as standard test in the new (1989) Swiss standard on concrete construction [3].

The contribution presents the basic assumptions on frost resistance and critical degree of saturation, the essential differences between the EMPA-Method and the Fagerlund-RILEM-Method and gives some results on the relation to established frost-resistance-tests. (scaling resistance, E-Modulus as a function of frost-cycles)

Basic assumptions

1. Practically all damages caused by frost action occur at surfaces of on-site concrete where fluid water is present when freezing starts. This situation is created intentionally by using deicing agents. This is the main reason why frost-deicing-salt-damages are much more frequent than "pure" frost-damages.
2. Frost actions causes damages in concrete only at places where the degree of saturation lies above the critical value. The damages consist of an expansion of the capillary pores in which the water is freezing. Thus in each following thaw-freeze-cycle the amount of freezable water at these places is somewhat larger. That makes the damages grow progressively until they finally become visible as chips scaled off the surface.
3. The critical degree of saturation is a materials constant mainly dependent on the structure of the pore system in the hardened cement paste. For "ordinary" Swiss concrete we found the following relation [4] between the mean values of total-porosity (n), airpore content (a) and critical water content U_{cr} ($= n \cdot S_{cr}$) :

$$U_{cr} = 0.94 \cdot n - 0.37 \cdot a + 0.3 \text{ Vol.}\%$$

$$N = 142; s(U_{cr}) = \pm 0.3 \text{ Vol.}\%$$

This equation rather underestimates the critical water content for old concrete and for cover-concrete, whereas it overestimates it for concrete with crushed or "alternative" aggregates, (probably because of the mica content). When air entraining agents are used, the equation fits well.

4. By capillary adsorption the air pores can't be filled although the pore system forms the continuing phase in the concrete and all pores are accessible from the surface. Consequently the mean value of the maximum attainable water content by capillary adsorption $U_{cap \max}$ is

$$U_{cap \max} = n - a$$

5. The ratio between the air pore content and the free pore space at critical water content can be used as a "frost-security factor"

$$FS = \frac{a}{n - U_{cr}}$$

by giving an indication about the "density" of critical places (re.2) where frost damage can start. We found that $FS \geq 1.5$ gives a low probability to get a bad result in an analogous frost resistance test as eg. the test fixed at the first TC 117 - meeting, respectively a low probability to get severe damages due to frost action on site.

6. The extent and the severeness of frost damages is dependent on
 - the state of saturation under freezing
 - the relevant properties of surface concrete
 - the micro climate at the concrete surface (total number of frost cycles, speed of temperature drop, minimum freezing temperature, frequency of frost cycles etc.)

Thus there is no direct correlation between the result of an analogous test and the behaviour of on-site-concrete.

A good result in a analogous test gives a low probability to get severe damages on site only when frost-cycles, state of saturation and the relevant properties of the test specimen are on the "safe side".

There is little known about the pessimal combination of influencing factors in relation to frost action.

Difference between "EMPA" and RILEM - "Fagerlund"-Method

1. The principle of measuring on one side the maximum attainable degree of saturation and on the other side the critical degree of saturation where frost-action starts to cause damages (repeated frost-cycles) is the same.
2. The test is made on cores with dimensions $d = h = 50$ mm because
 - this type of specimens is traditional and well tried in Switzerland to measure on-site concrete-properties.
 - it is difficult to get the same level of vacuum saturation (total porosity) in specimens of different size and shape.
3. The "damage" that defines the critical degree of saturation is a volume change of 1 ‰ after 6 frost-cycles measured by weighing the specimens above and under water. By this the only requirement to meet by this specimens is the total volume.
(balances accuracy = 0.01 g \Rightarrow Volume \cong 100 cm³).
4. The predrying of specimens is more moderate (2 d at 50°C without forced ventilation) to save a "natural" amount of "original" non freezable water in the gelpores.
5. In both parts of the test all degrees of saturation are reached by adsorption because of the hysteresis of sorption isothermes. Total vacuum saturation and total drying at 105°C is done at the end of the test only.
6. Only the maximum attainable degree of saturation defined as saturation after 14 d of capillary suction (3 mm in water) plus 2 d storage under water is considered to estimate the frost resistance. The nick-point and the development of saturation after the nick-point are not taken into account because they seem to be dependent on the procedure.
[eg predrying, shape of specimen etc.]

Experiences Limitations

1. As stated before there is a good but by definition only stochastic relation between the different frost resistance test methods and consequently also between tests and on site behaviour. It has been shown that there occurred large frost-damages on large dams where the critical degree of saturation was lower than the maximum attainable degree of saturation by adsorption and this saturation was attained in practice $S_{cr} < S_{cap\text{-}max} \cong S_{act}$ whereas there were first signs of small damages where $S_{cr} \cong S_{cap\text{-}max} \cong S_{act}$.

2. The critical degree of saturation method doesn't give reliable information on frost resistance of lightweight aggregate concrete. There the degree of saturation of the aggregate in fresh concrete is the determining factor: It should be below the critical value for the aggregate but it can't be determined on hardened concrete.
3. There are close relations between porosity, concrete composition, age and strength. Measuring the porosity therefore completes the informations on overall concrete quality. On the other hand these relations make it possible to measure reliably the frost-resistance on fresh concrete. [4, 5]

Conclusions

Out of all these "findings" we concluded that the critical degree of saturation method is most advantageous to measure the frost resistance of concrete, because

- it gives complementary informations about overall concrete quality.
- it is applicable to cores and is consistent with fresh concrete control.
- it measures the density of critical points where frost action can cause damages under pessimal conditions and hence is adapted to the probabilistic nature of frost-resistance
- it gives frost-resistance as a materials property practically independent on test conditions.

Literature:

- [1] G. Fagerlund : The critical degree of saturation method of assessing the freeze / thaw resistance of concrete. RILEM committee 4 CDC
Materiaux et construction Vol 10 No 58 1977

- [2] EMPA : Testing of water conductivity, frost resistance and frost-thawing salt resistance.
Guidelines for testing
EMPA Concrete / Binders Section CH-8600 Dübendorf

- [3] Norm SN 562 162/1 : Betonbauten Materialprüfung
Ausgabe 1989
Schweizerischer Ingenieur- und Architekten-Verein CH-8039 Zürich 6/1989

- [4] W. Studer : Testing of Frost Resistance on Fresh Concrete
Proc. RILEM Seminar : Durability of Concrete Structures under Normal Outdoor
Exposure (Hannover 26./29. March 1984)

- [5] W. Studer : Determination of Concrete Quality by Means of Small Diameter Cores.
Proc. of International Symposium "Re-evaluation of Concrete Structures"
(Copenhagen 13./15. June 1988)



**THE EFFECTS OF LOW TEMPERATURES AND FREEZE-THAW
CYCLES ON THE STABILITY OF HYDRATION PRODUCT**

**Jochen Stark
and
Horst-Michael Ludwig**

**University of Architecture and Building
Weimar, Germany**

Prof.Dr.-Ing.habil. Jochen Stark
Dipl.-Ing. Horst-Michael Ludwig
University of Architecture and Building, Weimar

The effects of low temperature and freeze-thaw cycles on the stability of hydration products

The influence of the type of cement and the phases of Portland cement on the resistance to freezing and thawing of concrete has been the subject of discussion for a long time. Within this set of problems the assesment of the possibility of phase displacements of AF_m - and AF_t -phases was the intention of the experiments.

1. Materials

Basic cements for the investigations were Portland cement (SRPC 40 A) with a low C_3A -content ($C_3A = 1,7 \%$) and a C_3A -rich white cement ($C_3A = 10,7 \%$).

The experiments were carried out with samples of C_3A and $C_2(A,F)$ obtained by salicylic acid extraction from these technical cements. The results of this extraction are shown in the table 1.

Most of the silicat clinker phases were seperated and the aluminat - and the ferrat phases were concentrated in the extraction residue. Beside this phases most alkalies and sulphates were insoluble in the acid solution too.

The extraction of the basic cements can also be observed by roentgenography (figure 1 and 2). The materials prepared on this way exactly correspond to the clinker aluminates and ferrites both in nature and quantity of incorporated foreign oxides and in their hydraulic activity.

Table 1: Results of the salicylic acid extraction

Chemical analysis before and after the extraction:

	SRPC 40 A		PC White	
	basic PC	after extr.	basic PC	after extr.
SiO ₂ %	19,8	5,6	22,0	7,5
Al ₂ O ₃ %	4,4	14,9	4,2	19,7
Fe ₂ O ₃ %	5,7	20,4	0,2	0,7
CaO %	65,8	44,4	68,2	44,6
MgO %	1,6	3,1	2,3	9,9
K ₂ O %	0,70	2,20	0,32	1,41
Na ₂ O %	0,23	0,51	0,12	0,56
SO ₃ %	2,0	7,8	2,2	13,2
CaO _{fr.} %	1,9	0,1	0,6	0,1

Main phases before and after the extraction:

SRPC 40 A		PC White	
basic PC	after extr.	basic PC	after extr.
C ₃ S = 65,6 %	C ₄ AF = 62,1 %	C ₃ S = 70,8 %	C ₃ A = 51,1 %
C ₂ S = 6,4 %	C ₃ S = 10,3 %	C ₂ S = 8,0 %	C ₃ S = 6,4 %
C ₃ A = 1,7 %	CaSO ₄ = 11,4 %	C ₃ A = 10,7 %	CaSO ₄ = 19,7 %
C ₄ AF = 17,3 %	MgO = 3,1 %	C ₄ AF = 0,6 %	MgO = 9,9 %

2. Experimental investigations

The extraction residues were hydrated by an saturated lime solution at a solution/residue ratio of 1,0 and placed in small closed bottles until the beginning of the experiments after 90 days' hydratation time. Then the water-saturated samples were subjected to following treatments:

- storage at + 20 °C - 30 days
- storage at + 5 °C - 30 days
- storage at - 5 °C - 30 days
- 150 freeze-thaw cycles - 30 days
+ 20 °C/-20 °C

The differential thermo-analysis was used for the examination of the stability of sulfoaluminathydrates during the frost loading. The results of this investigations are exhibited on figure 3 and figure 4. It is discernible that after the temperature treatment a distinct phase displacement from monosulphate respectively AF_m-phase to ettringite respectively Af_t-phase independent of the kind of residue was stated at decreasing temperature. Approximate quantitativ informations about the phase displacement can be obtained by means of thermogravimetry (TG). The results are shown in table 2.

Table 2: Phase content after different treatments

Treatment	SRPC 40 A		PC W	
	AF _m	AF _t	AF _m	AF _t
+ 20 °C	61 %	5 %	40 %	27 %
+ 5 °C	57 %	7 %	36 %	29 %
- 5 °C	47 %	20 %	26 %	40 %
150 ft	53 %	15 %	34 %	32 %

The greatest displacement to ettringite was shown at a constantly negative temperature (- 5 °C).

The investigations by means of roentgenography and electron scan microscope confirmed the results of the thermoanalytical examinations. The roentgenograms of the samples after the temperature treatments are to be seen in figure 5 and figure 6. In the case of roentgenography a quantitative analysis is not possible. The reason is that the ettringite which is arised secondary behaves in amorphous shape partially.

The increasing of the ettringite phase is good to be observed by means of electron scan microscope (figure 7 to 12).

The amount of ettringite needles is raised during the freezing and thawing clearly. However, the morphology of ettringite (AF_t) which was formed at constantly negative temperatures differed considerably from the usual needle - shaped formation.

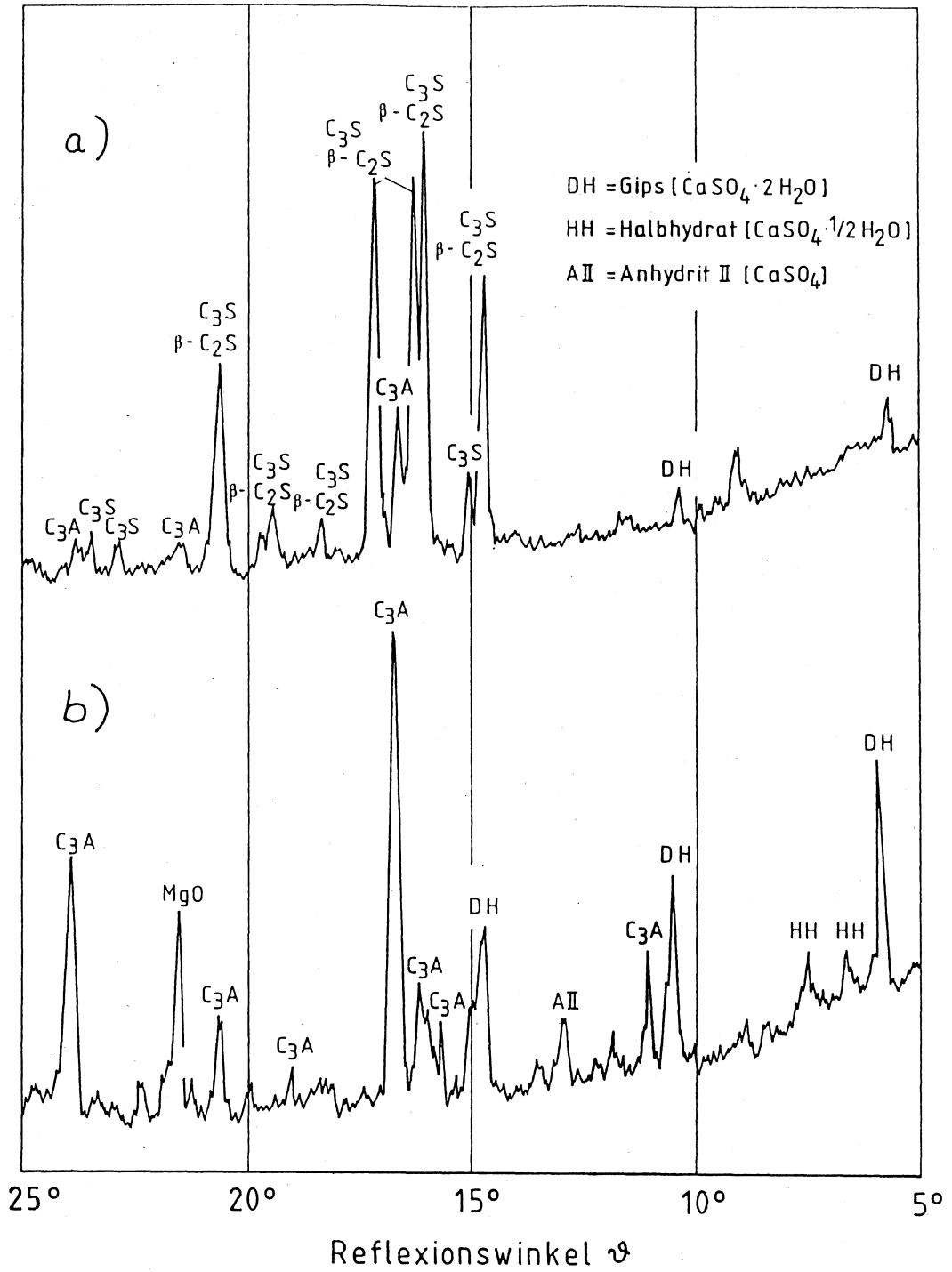

Figure 1: Roentgen spectrums of PC White
a) basic cement
b) extraction residue

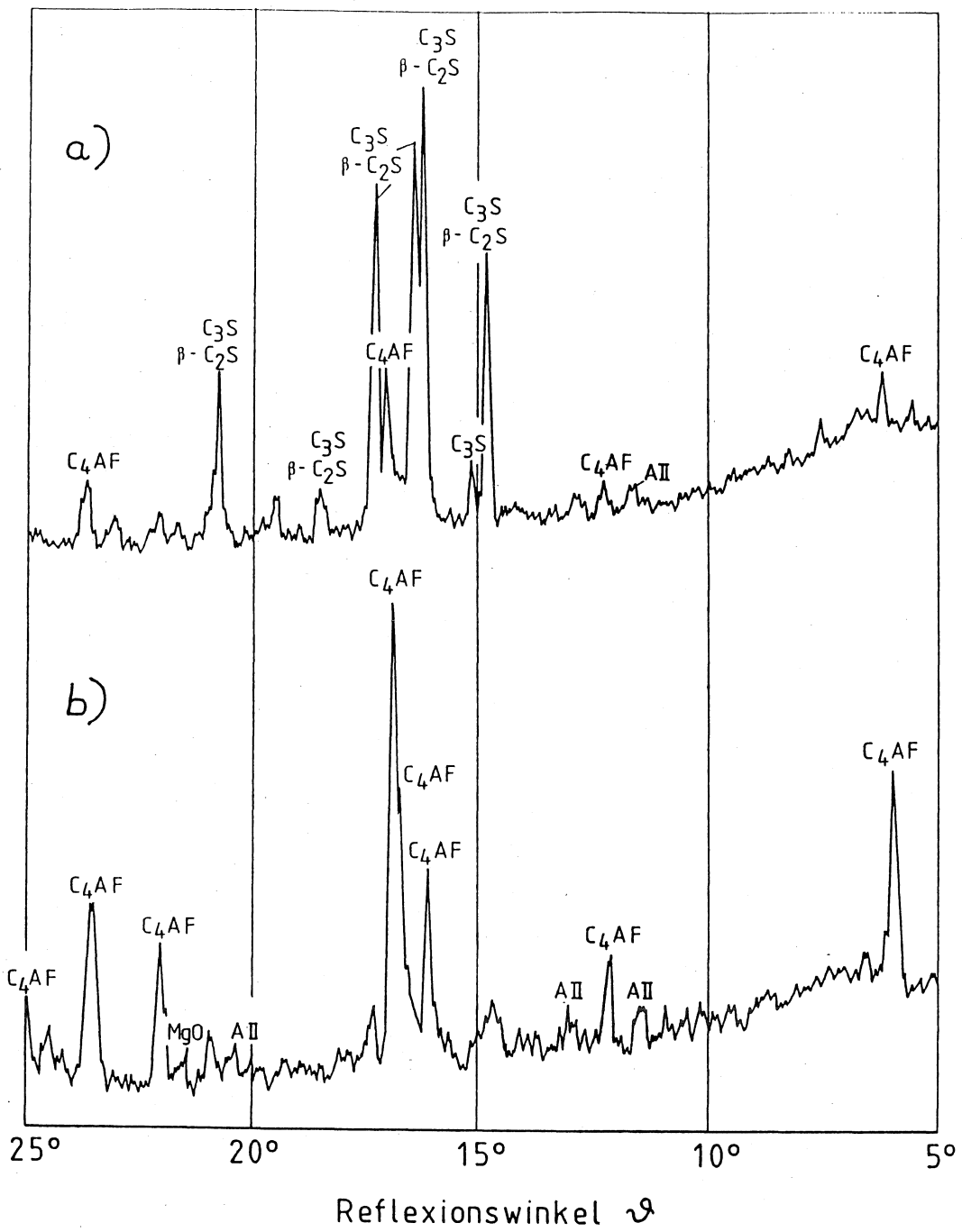

Figure 2: Roentgen spectrums of SRPC 40 A
a) basic cement
b) extraction residue

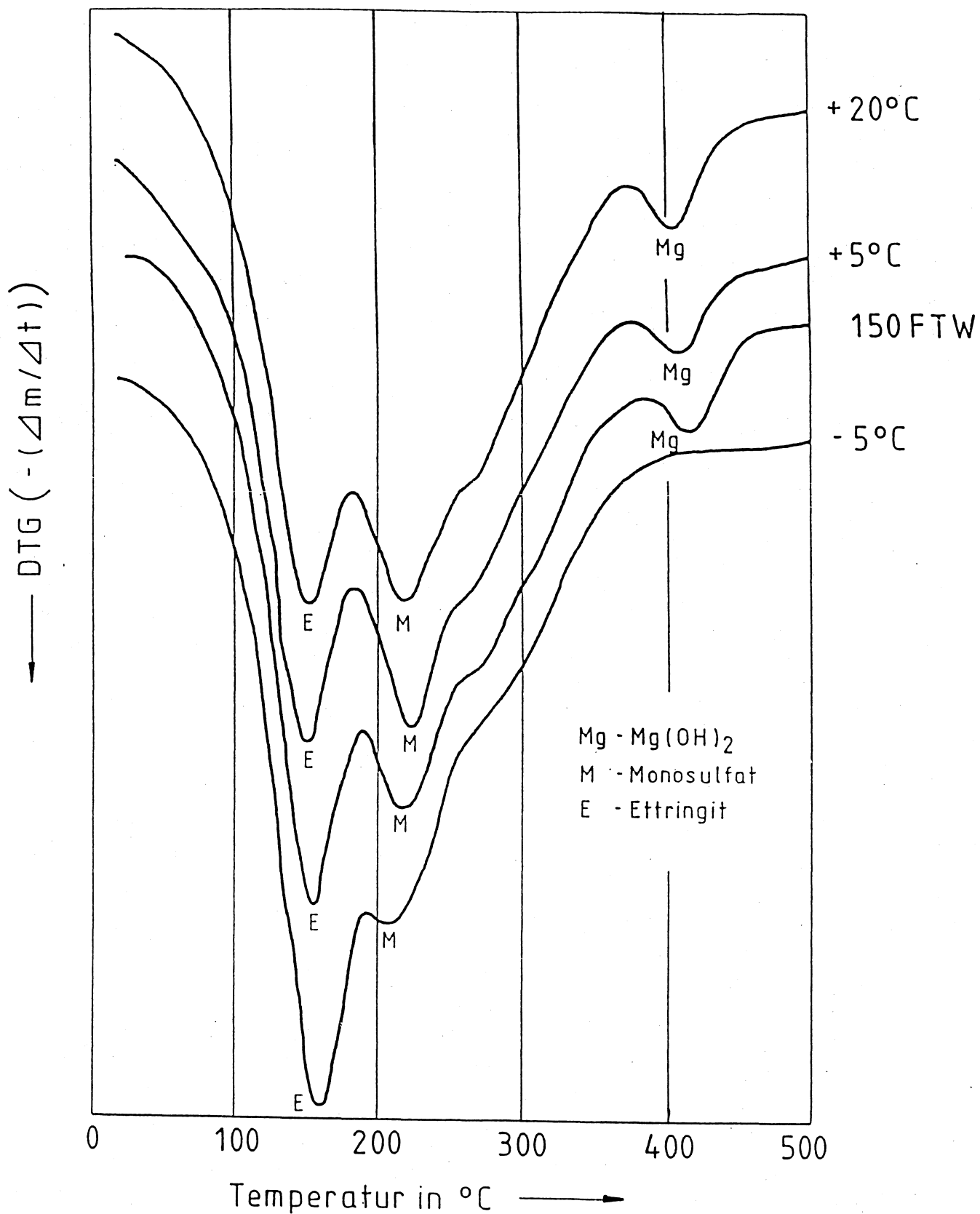

Figure 3: DTG curves of PC White after temperature treatments

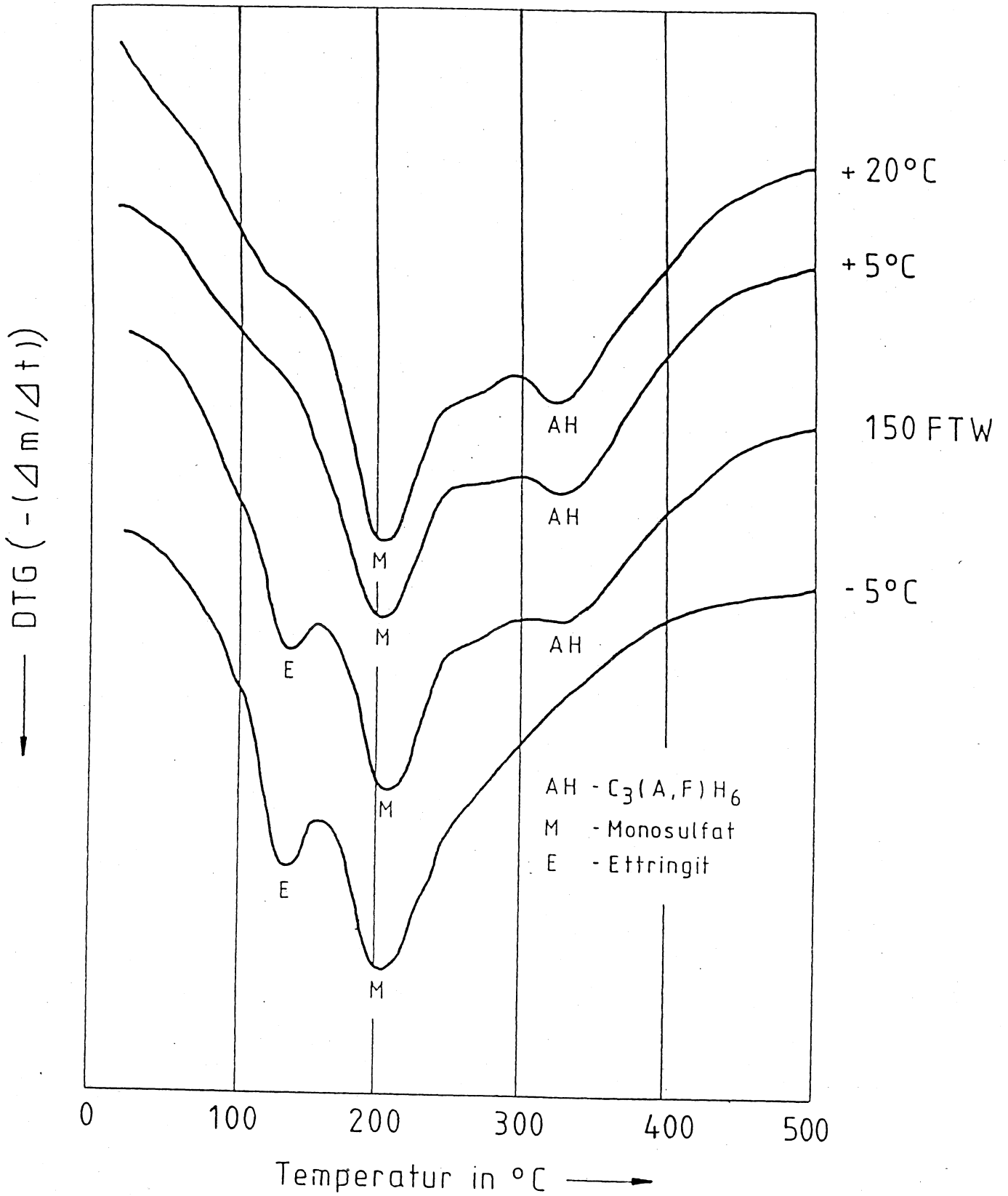

Figure 4: DTG curves of SRPC 40 A after temperature treatments

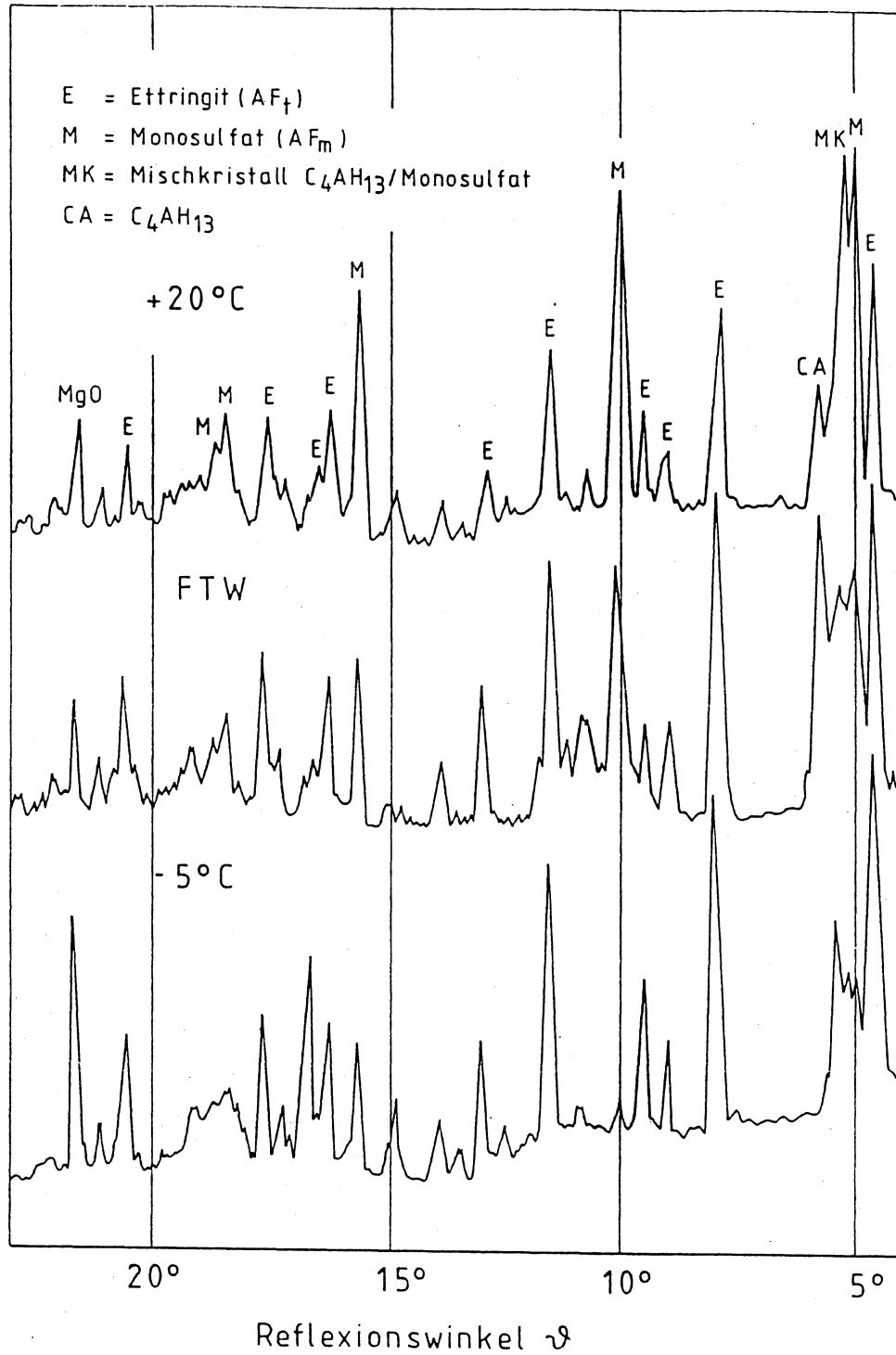

Figure 5: Roentgen spectrums of PC White after temperature treatments

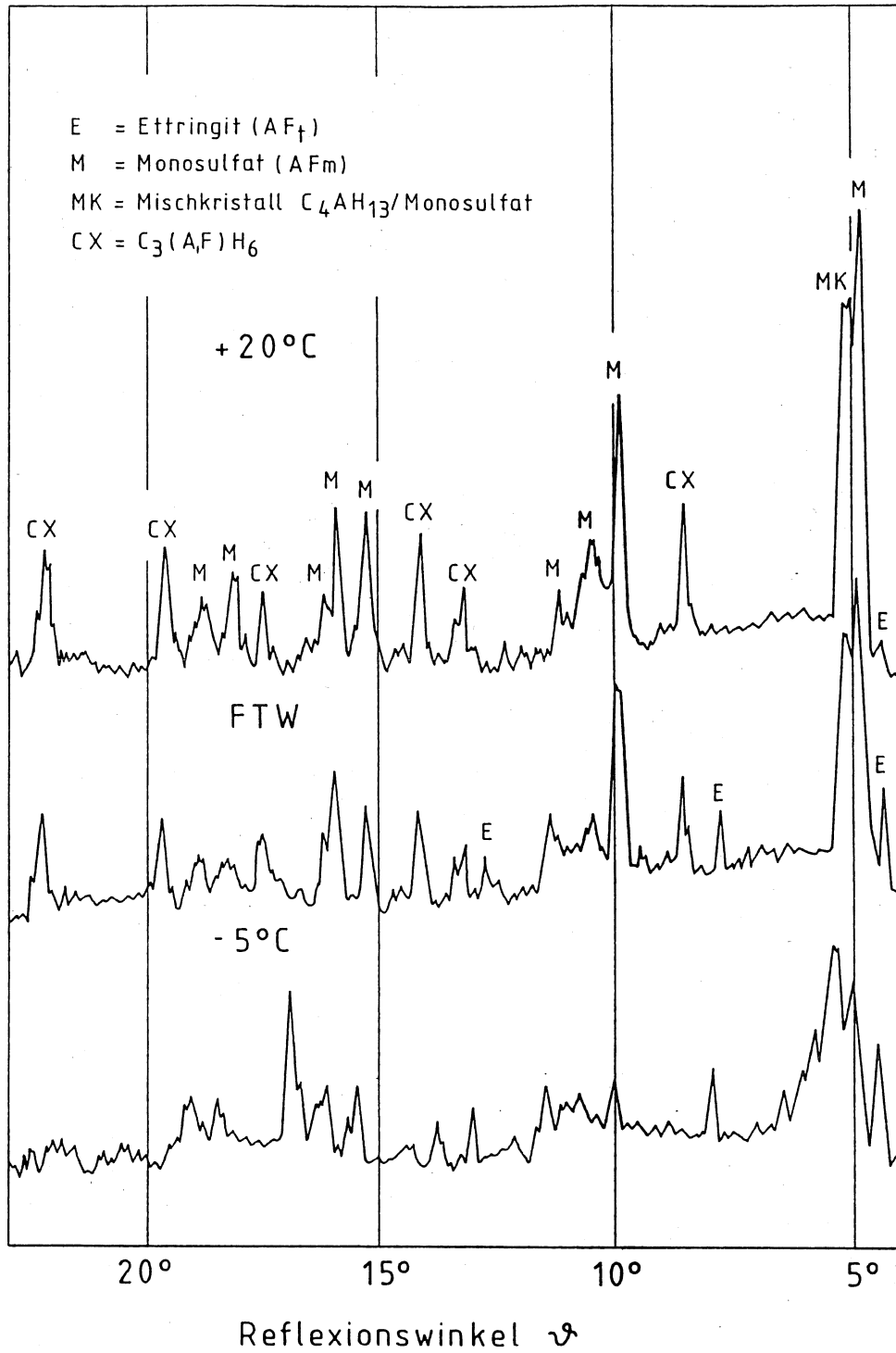

Figure 6: Roentgen spectrums of SRPC 40 A after temperature treatments

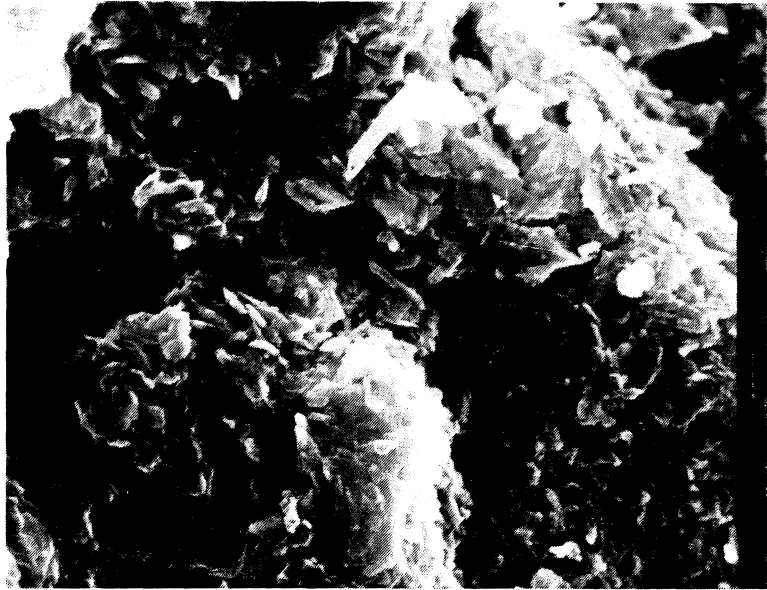

Figure 7: 120 d - hydrated PC White - storage at +20 °C



Figure 8: 120 d - hydrated PC White - 150 freeze - thaw cycles / 30 d

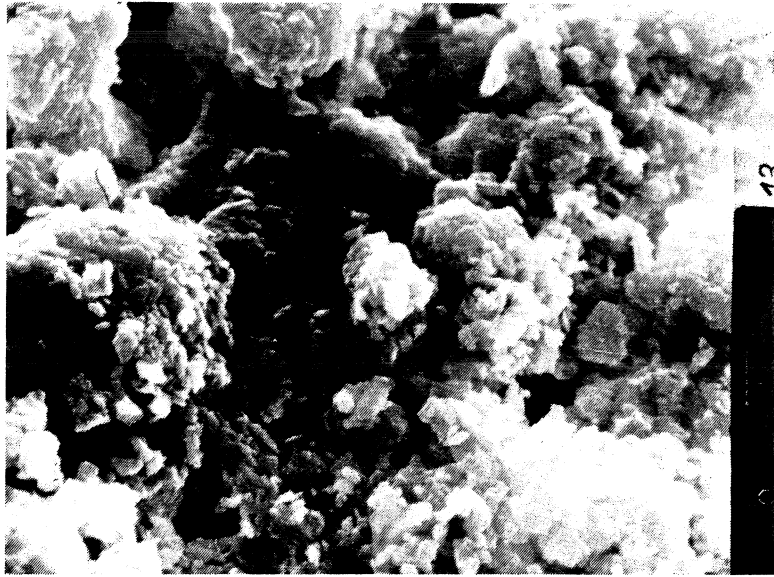

Figure 9: 120 d - hydrated PC White - storage at -5 °C / 30 d

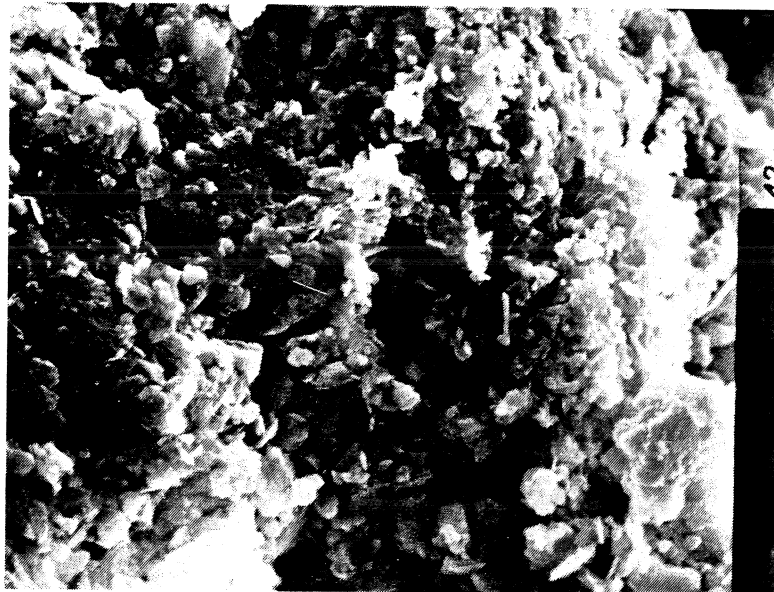

Figure 10: 120 d - hydrated SRPC 40 A - storage at +20 °C

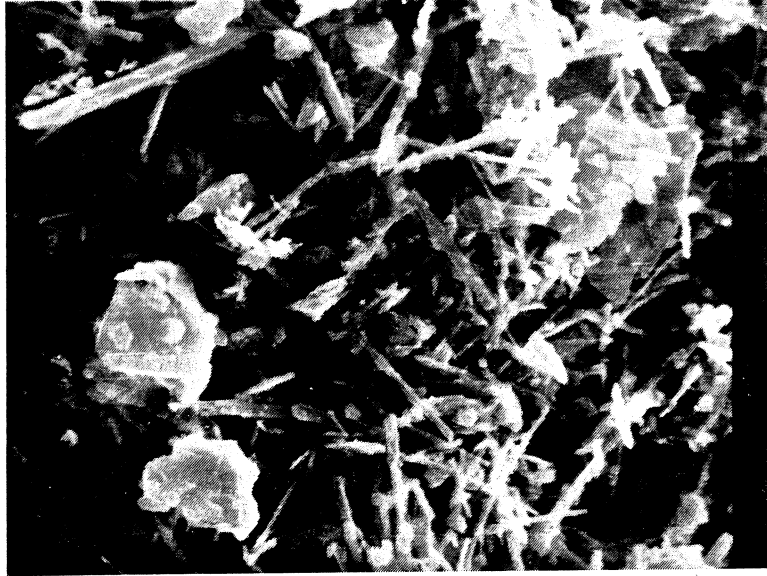

Figure 11: 120 d - hydrated SRPC 40 A - 150 freeze - thaw cycles / 30 d

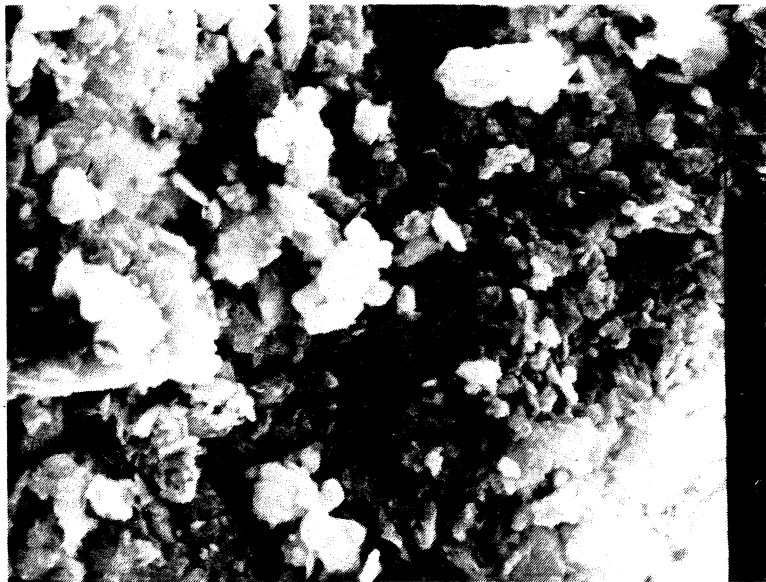
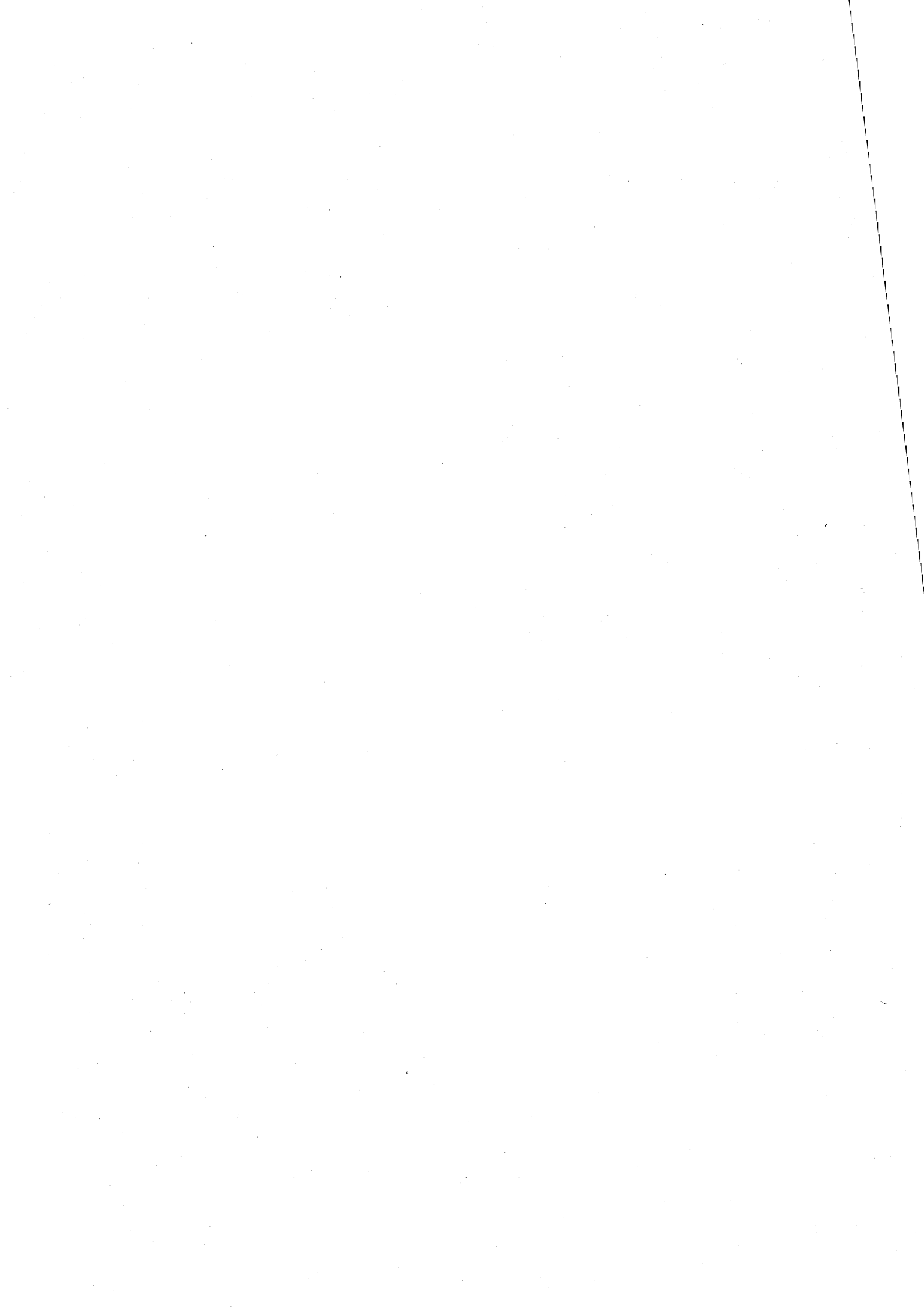

Figure 12: 120 d - hydrated SRPC 40 A - storage at -5°C / 30 d



THE INFLUENCE OF THE C₃A CONTENT ON THE DURABILITY AT
FREEZING AND THAWING

Jochen Stark
and
Sylvia Stürmer

University of Architecture and Building
Weimar, Germany

Prof.Dr.-Ing.habil. Jochen Stark
Dipl.-Ing. Sylvia Stürmer
University of Architecture and Building, Weimar

The influence of the C_3A -content on the durability at
freezing and thawing

1. Introduction

Connected with increasing damages on cementbound concrete in East-Germany and the following investigations about the durability of concrete demands are made on the cements and aggregates. Because of the damages by sulphate attack and late ettringite formation (without supply of sulphate from outside) it was demanded to change the ratio of SO_3 to Al_2O_3 of the cement. A changing of the Al_2O_3 -content is connected with a variation of C_3A -content in cement. Beside the effects of C_3A in cement on:

- heat of hydration
- setting time
- strength development
- shrinkage - and expansion performance and
- sulphate attack

effects on the durability at freezing and thawing will be expected too.

2. Materials

The investigations about influence of C_3A content on the durability at freezing and thawing were carried out with mixtures of commercial Portland cements and with laboratory-made cements.

2.1. Mixtures of commercial Portland Cements

Original materials for the variation of C_3A -content were a sulphate-resisting Portland cement and a white Portland cement. Both are comparable in the contents of Alit and Alkalies, but extreme different in C_3A -content (table 1). The cements were mixed, and cements with following differing C_3A -contents were obtained (figure 1).

Table 1:

Analytical data of basic cements PC-W and PC-SR 40 A

	PC-W	PC-SR 40 A
L.O.I. (%)	2,18	0,65
CaO	66,41	64,91
SiO	21,21	19,14
Al ₂ O ₃	4,17	4,25
Fe ₂ O ₃	0,24	5,64
SO ₃	2,36	2,03
Na ₂ O	0,13	0,11
K ₂ O	0,16	0,27
MgO	2,60	1,38
spec. Area (cm ² /g)	4300	3800
KST	100	99
SM	4,81	1,93
TM	17,38	0,75
C ₃ S (%)	71,6	68,6
C ₂ S	6,8	3,1
C ₃ A	10,6	1,7
C ₂ (A,F)	0,7	17,2

2.2. Laboratory-made cements

Raw mixtures of natural materials with variable TM and almost constant KST, SM and Na₂O-equivalent were burned at 1450 °C for 30 minutes to get clinkers with varying C₃A-contents. The clinkers was ground with gypsum. The gypsum was charged corresponding to the optimum sulphate content by OST/LERCH.

The obtained cements have an uniform specific area of 3500 cm²/g (Blaine). The composition ist shown in table 2. A view about the cements, the conditions of manufacture and storage of standard mortar prism and the measurements shows figure 1.

Table 2: Analytical data of laboratory-made cements

	analytical data				
CaO (%)	68,23	68,14	67,65	68,58	68,95
SiO	21,50	21,38	21,80	22,25	21,63
Al ₂ O ₃	3,42	4,38	5,01	5,56	6,37
Fe ₂ O ₃	5,33	4,79	3,68	2,12	1,92
SO ₃	0,40	0,32	0,27	0,40	0,30
K ₂ O	0,66	0,78	0,88	0,82	0,76
Na ₂ O	0,05	0,07	0,05	0,05	0,05
MgO	0,61	0,20	-	0,20	-
<hr/>					
KST	101	100	98	99	100
TM	0,64	0,92	1,36	2,62	3,32
SM	2,46	2,33	2,51	2,89	2,71
Na ₂ O <i>äq.</i>	0,48	0,58	0,63	0,59	0,55
SG (%)	64	43	33	53	42
<hr/>					
Composition (BOGUE)					
C ₃ S (%)	81,7	81,3	82,9	84,6	82,2
C ₂ S	-	-	-	-	-
C ₃ A	0	3,5	7,0	11,1	13,6
C ₄ AF	16,2	14,6	11,2	6,4	5,8
C ₂ F	-	-	-	-	-
<hr/>					
SO ₃ <i>opt</i> (%)	2,04	2,10	2,21	2,38	2,40
SO ₃ <i>zem</i> (%)	2,10	2,20	2,40	2,50	2,50
SO ₃ / Al ₂ O ₃ <i>incl.</i>	0,78	0,64	0,61	0,57	0,50

3. Results

The standard mortar prism were exposed to freezing and thawing (3 changes per day between -25°C and $+25^{\circ}\text{C}$) after water storage of 90 days.

3.1. Compressive strength

The compressive strengths of mixed cements after 50 and 100 freezing and thawing are compared with those of normal hardened prism after equal time (figure 2). The compressive strength increases with rising of the C_3A -content. On one hand the measured strength increases linearly with C_3A -content. On the other hand the differences of compressive strength between frozen and unfrozen mortar prism becomes smaller with increasing C_3A -content.

Furthermore the influence of the water-cement-ratio at differing C_3A -contents on freezing and thawing was investigated with the original commercial cements.

As Figure 3 a shows, is the hight of loss of compressive strength at frozen and unfrozen prism made of PC-SR practically independent of the water-cement-ratio. It amounts in the examined range $0,4 \leq \text{W/C} \leq 0,6$ to $\Delta R_c = 20 \text{ N/mm}^2$ after 50 freezing and thawing respectively $\Delta R_c = 28 \text{ N/mm}^2$ after 100 freezing and thawing.

As opposed to that the loss of compressive strength at PC-W increases with rising water-cement-ratio (figure 3 b). The PC-W mortar prism made with a water-cement-ratio of 0,4 do not show any loss of compressive strength.

At a water-cement-ratio of 0,6 the loss of compressive strength amounts to $\Delta R_o = 25 \text{ N/mm}^2$ after 50 freezing and thawing respectively $\Delta R_o = 43 \text{ N/mm}^2$ after 100 freezing and thawing. Figure 4 shows the compressive strength of laboratory - made cements after 50, 100 and 150 freezing and thawing and the strength before freezing and after 141 days normal hardening. 141 days correspond to the hardening time of prism exposed to 150 freezing and thawing. The durability at freezing and thawing of laboratory - made cements increases with rising content of C_3A too. The differences of compressive strength between freezed and unfreezed mortar prism become smaller with increasing C_3A -content.

3.2. Expansion measurements

The mortar prism made of C_3A -rich PC-W show after one year of normal hardening a little higher expansions than the mortar prism made of PC-SR with low C_3A -content.

$$\Delta l/l \text{ PC-W 360 d} = 0,19 \text{ mm/m}$$

$$\Delta l/l \text{ PC-HS 360 d} = 0,12 \text{ mm/m}$$

The mortar prism exposed to freezing and thawing expand more strongly than the normal hardened one. The expansion over 10 mm/m lead to the completely damage of prism.

Figure 6 shows the prism after 150 freezing and thawing. The prism made of C_3A -free laboratory cement were completely damaged. The expansion decreases from 13 mm/m ($C_3A = 3,5 \%$) up to 1,7 mm/m ($C_3A = 13,6 \%$).

Summary

The strength performance and the expansion of cements with varying C_3A -content were investigated at normal hardening and at freezing and thawing. On one hand the variation was realised by mixing commercial cements with extreme C_3A -content and on the other hand by manufacturing laboratory cements. The results at freezing and thawing of both cement types with high C_3A -content are substantially better than those of cements with low C_3A -content. The losses of compressive strength of C_3A -rich cements at freezing are clearly connected with increasing porosity. The cement with low C_3A -content is in this experiments not durable at freezing by non air-entrained agents. This result can not be improved by decreasing the water-cement-ratio. In this case the losses of strength are independent of porosity - varied by changing the water-cement-ratio - and that's why it can not only be based on physical phenomena. Chemical processes at freezing must also be taken into account. Further investigation should help to find the causes.

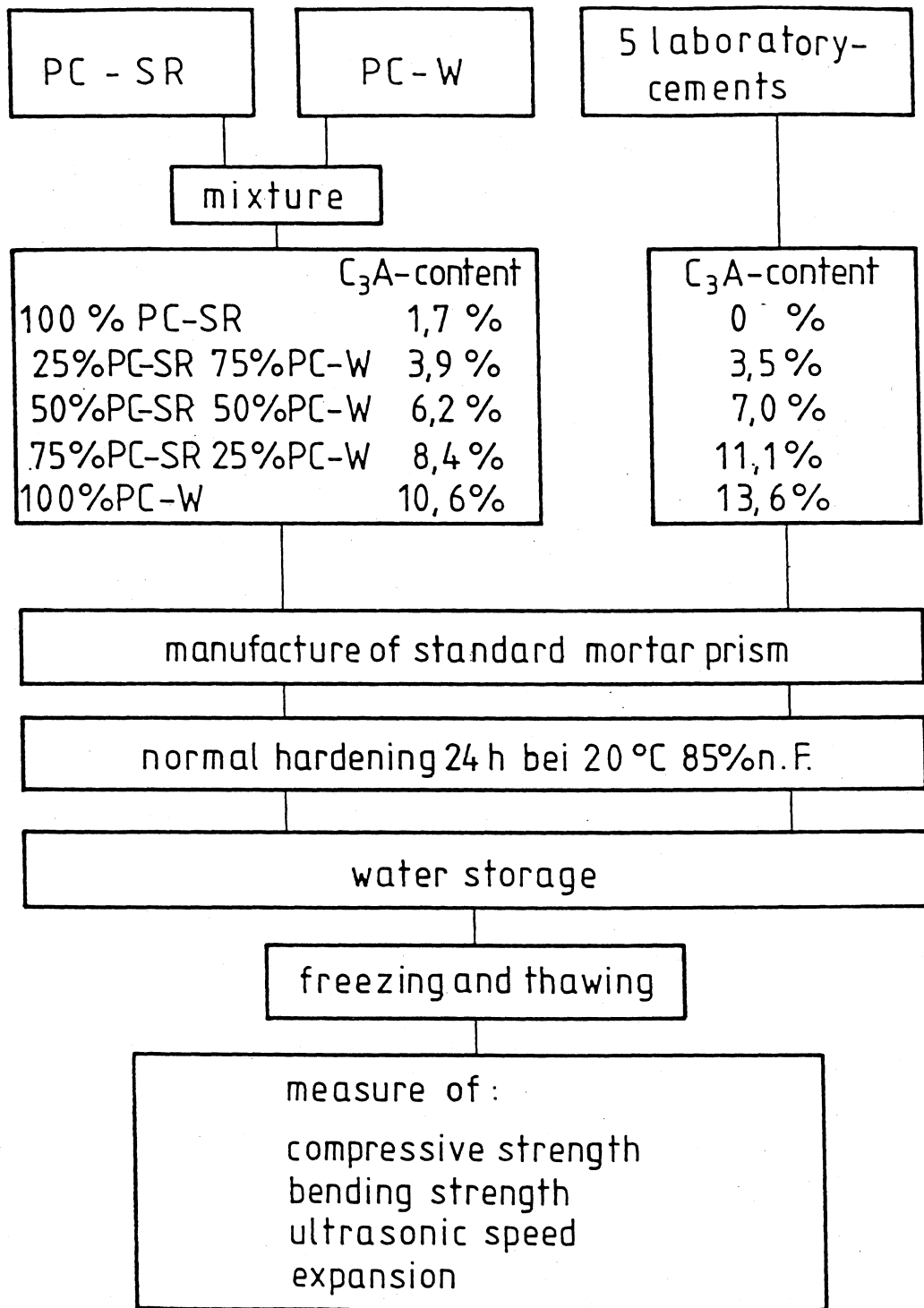

Figure 1: Experimental program

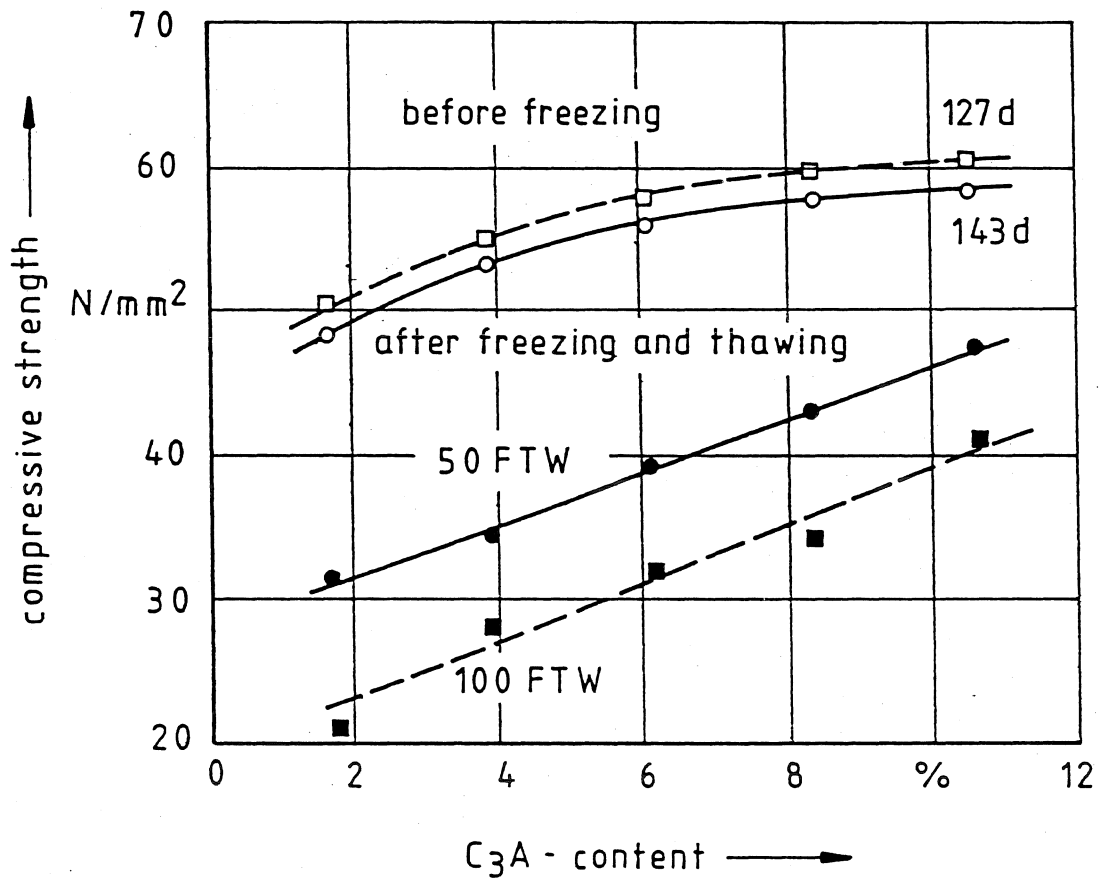

Figure 2: Compressive strength of mixed cements vs the C₃A-content at freezing and thawing

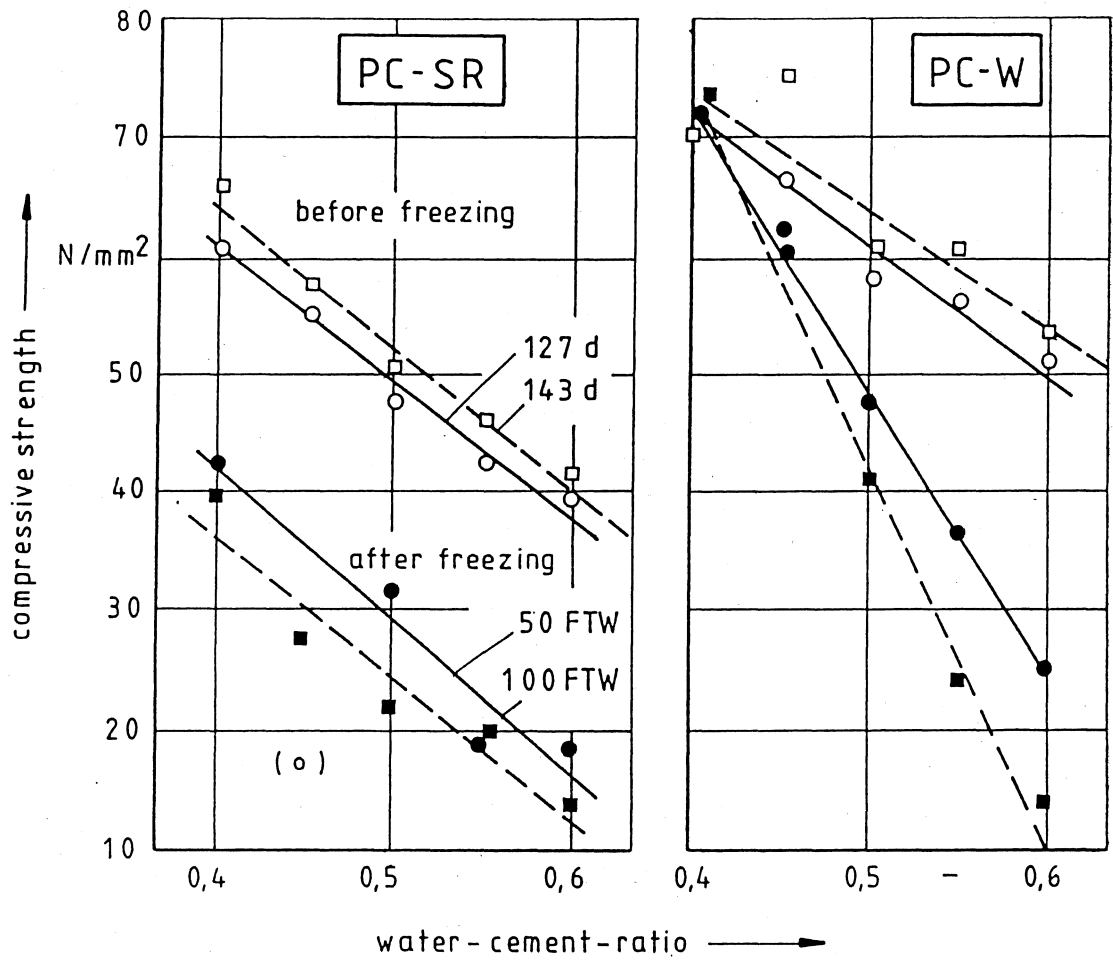

Figure 3: Compressive strength at normal freezing and hardening vs water-cement-ratio
a) of sulphate-resiting PC
b) of white PC

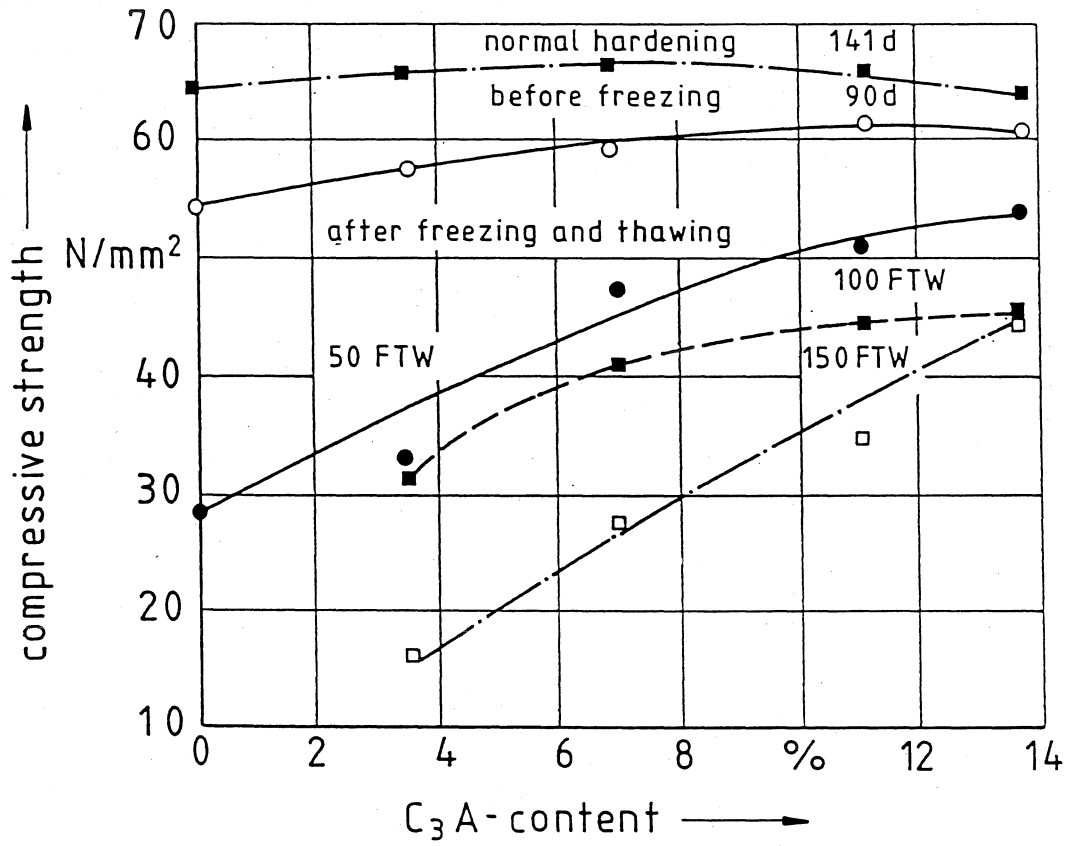

Figure 4: Compressive strength of laboratory-made cements vs the C₃A-content at freezing and thawing

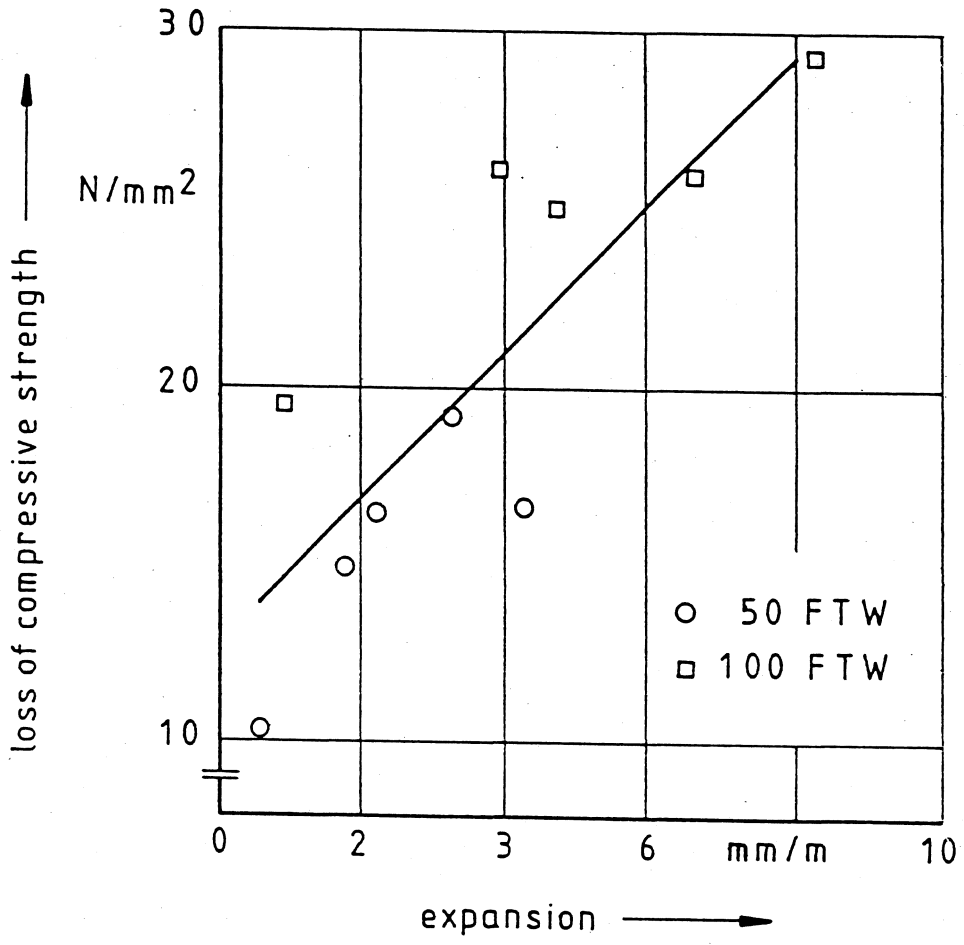

Figure 5: Loss of compressive strength vs expansion

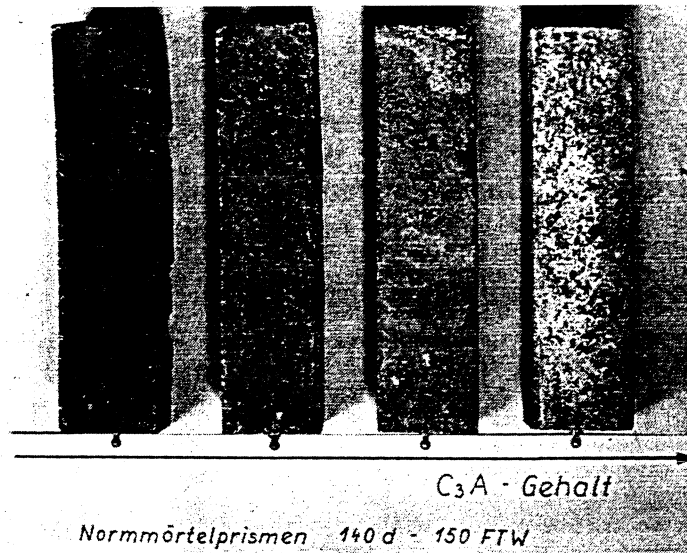

Figure 6: Prism made of laboratory cements after 150 freezing and thawing