



# LUND UNIVERSITY

## Genetic characterization of bone and soft tissue tumors

Mandahl, Nils; Mertens, Fredrik; Panagopoulos, Ioannis; Knuutila, S.

*Published in:*

Acta Orthopaedica Scandinavica. Supplementum

*DOI:*

[10.1080/00016470410001708290](https://doi.org/10.1080/00016470410001708290)

2004

[Link to publication](#)

*Citation for published version (APA):*

Mandahl, N., Mertens, F., Panagopoulos, I., & Knuutila, S. (2004). Genetic characterization of bone and soft tissue tumors. *Acta Orthopaedica Scandinavica. Supplementum*, 75(311), 21-28.  
<https://doi.org/10.1080/00016470410001708290>

*Total number of authors:*

4

### General rights

Unless other specific re-use rights are stated the following general rights apply:

Copyright and moral rights for the publications made accessible in the public portal are retained by the authors and/or other copyright owners and it is a condition of accessing publications that users recognise and abide by the legal requirements associated with these rights.

- Users may download and print one copy of any publication from the public portal for the purpose of private study or research.
- You may not further distribute the material or use it for any profit-making activity or commercial gain
- You may freely distribute the URL identifying the publication in the public portal

Read more about Creative commons licenses: <https://creativecommons.org/licenses/>

### Take down policy

If you believe that this document breaches copyright please contact us providing details, and we will remove access to the work immediately and investigate your claim.

LUND UNIVERSITY

PO Box 117  
221 00 Lund  
+46 46-222 00 00

# Genetic characterization of bone and soft tissue tumors

N. Mandahl<sup>1</sup>, F. Mertens<sup>1</sup>, I. Panagopoulos<sup>1</sup> and S. Knuutila<sup>2</sup>

<sup>1</sup>Dept of Clinical Genetics, Lund University Hospital, Lund, Sweden, <sup>2</sup>Depts of Pathology and Medical Genetics, Haartman Institute and Helsinki University Central Hospital, Helsinki, Finland  
niils.mandahl@klingen.lu.se

During the last 20 years, genetic analyses of bone and soft tissue tumors (BSTT) have revealed that most histopathologic entities investigated in sufficient detail are characterized by acquired, clonal chromosome aberrations. Many of these rearrangements are nonrandom and several of them are strongly associated with specific histopathologic tumor subtypes. Cytogenetic studies using chromosome banding techniques have been an important first mapping step that has guided further efforts to identify mutations at the gene level by fluorescence in situ hybridization (FISH), reverse-transcriptase polymerase chain reaction (RT-PCR) and other molecular techniques. Chromosomal comparative genomic hybridization (CGH), and more recently CGH microarray techniques, have revealed many specific amplicons in various sarcomas. The strong association between chromosome or gene rearrangements and tumor subtype has more and more been exploited to aid the diagnostic work. Less conclusive data are available as regards the role of genetic aberrations for disease progression, but there are reports indicating that some genetic changes may provide prognostically important information. Even less is known about the origin of chromosome mutations and the relation between genetic aberrations and abnormal cellular processes associated with tumorigenesis.

Cytogenetic analysis still holds a strong position as a screening technique to detect previously known as well as new chromosome aberrations. However, the resolution level is low—seemingly identical translocations may affect completely dif-

ferent genes—and the success rate (the finding of clonal chromosome aberrations) after short-term culturing is typically 50-70% at most laboratories. FISH and molecular genetic analyses are sensitive with a high resolution but have no or poor screening capacity. CGH is another powerful screening technique to detect genomic imbalances. CGH allows analysis of large cell populations at a resolution down to the subband level. Imbalances in tumors with multiple, complex aberrations can be identified with much better precision than by cytogenetics. Conversely, in contrast to CGH, cytogenetics allows detection of balanced rearrangements, genetic heterogeneity and clonal evolution. On the other hand, because chromosome banding analysis is dependent on metaphase cells there is a potential risk that cell populations that are not prone to divide in vitro escape detection. So, with the ambition to do both clinical work and research, several techniques need to be applied.

## *Spectrum of genetic aberrations*

The type and complexity of karyotypes among BSTTs vary widely. The following main cytogenetic patterns may be distinguished:

1. Tumor-specific reciprocal translocations, frequently found as the sole chromosomal aberration.
2. Highly recurrent structural and/or numerical aberrations that are not associated with one particular tumor morphology.
3. Moderately or highly complex, partly nonrandom aberrations, often with distinct cytogenetic variation from cell to cell within the same tumor.

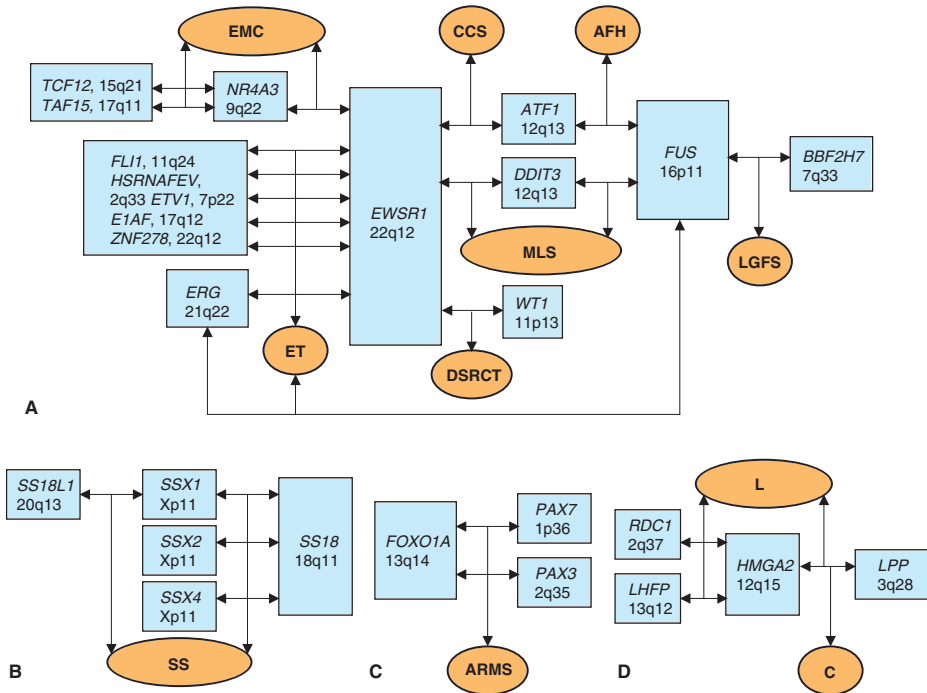

**Figure 1.** Schematic representation of some gene rearrangements in BSTT. Gene symbols and their chromosomal localization are shown in blue boxes. Double-headed arrows indicate translocations. Resulting tumors are specified in orange ellipses. Abbreviations: AFH angiomatoid fibrous histiocytoma, ARMS alveolar rhabdomyosarcoma, C chondroma, CCS clear cell sarcoma, DSRCT desmoplastic small round cell tumor, EMC extraskeletal myxoid chondrosarcoma, ET Ewing tumor, L lipoma, LGFS low grade fibromyxoid sarcoma, MLS myxoid liposarcoma, and SS synovial sarcoma.

In addition, recurrent amplicons associated with particular tumor subtypes have been identified.

Reciprocal translocations specifically associated with a particular tumor histotype have been identified in many BSTTs (Fletcher et al. 2002; Mitelman Database of Chromosome Aberrations in Cancer 2003), including alveolar rhabdomyosarcoma (ARMS), alveolar soft part sarcoma (ASPS), angiomatoid fibrous histiocytoma (AFH), chondroma, clear cell sarcoma (CCS), dermatofibrosarcoma protuberans (DFSP), desmoplastic small round cell tumor (DSRCT), Ewing tumors (ET), extraskeletal myxoid chondrosarcoma (EMC), inflammatory myofibroblastic tumor (IMFT), juvenile fibrosarcoma (JFS), lipoblastoma, lipoma, low grade fibromyxoid sarcoma (LGFS), myxoid liposarcoma (MLS) and synovial sarcoma (SS). Thus, these aberrations are present in both benign and malignant lesions, primarily among soft tissue tumors. At the molecular level, it has been shown that the translocation breakpoints disrupt genes that then form fusion genes as a result of

the exchange of chromosome material. Whereas reciprocal translocations result in the formation of two reciprocal fusion genes, some variant rearrangements give rise to only one fusion gene. This happens in complex translocations, involving three or more chromosomes, and, in rare cases, when a small chromosome segment, usually below the detection level of chromosome banding analysis, from one chromosome is inserted into another one. These novel, presumably oncogenic fusion genes, consisting of the 5'-part of one gene and the 3'-part of the other gene, are then transcribed and translated into chimeric proteins. In most cases, one member of these composite genes is a transcription factor gene (Åman, 1999).

Several tumor types display alternative translocations with one breakpoint in common, each resulting in a specific fusion gene and giving rise to morphologically indistinguishable tumors (Figure 1). Apart from this type of variation, some genes are not only involved with many fusion partners but also in several different tumor types. For exam-

ple, *EWSR1* has been found to fuse with 5 genes in ET, primarily *FLII* in about 90% of the cases (Figure 1). *EWSR1* fusion with four other genes, however, results in the development of MLS, CCS, EMC and DSRCT. Also *FUS*, a gene showing extensive similarity to *EWSR1* (Åman et al. 1996), is promiscuous and fuses with 4 different genes in MLS, LGFS, ES and AFH. Obviously, *EWSR1* and *FUS* are interchangeable to some extent. Both genes have been found to recombine with *DDIT3* in MLS, in which *FUS* is the preferred 5' fusion partner, and with *ERG* in ET where *EWSR1* is by far the most common 5' partner. Admittedly, only few cases of MLS with *EWSR1-DDIT3* and ET with *FUS-ERG* have been reported, so it remains to be seen whether tumors with common and uncommon fusion genes differ clinically or biologically.

Apart from this variation in fusion partners, there is also a heterogeneity at transcript or DNA level, i.e., the exact breakpoint localization within a gene may vary from case to case within the same tumor entity. This gives rise to variants of chimeric transcripts that typically show frequency differences with one or two dominating types. For example, no less than 9 variants of the *FUS/DDIT3* fusion transcript have been identified so far in myxoid and mixed myxoid round cell liposarcomas (Panagopoulos et al. 2000). In the most common variants, type 1 and type 2, *FUS* exons 5 and 7, respectively, are fused to exon 2 of *DDIT3*. Also among EMC, 9 different *EWSR1/NR4A3* fusion transcripts have been reported (Panagopoulos et al. 2002a). The two most common variants have been found in more than 60% and about 20%, respectively, of the cases with this chimeric gene, whereas the remaining types have been seen in only one or two cases. Similar figures are seen for the two dominating variants, out of four reported, of *EWSR1/ATF1* transcripts in CCS (Panagopoulos et al. 2002b). Moreover, more than one chimeric transcript from the same fusion gene may be generated. The presence of different transcripts in the same tumor may be explained by alternative splicing, the significance of which is not known. Different tumor entities that involve *EWSR1*, have different preferred transcript structures. Whereas joining of *EWSR1* exon 7 to one of several alternative exons in the partner gene is dominating in ES, MLS and DSRCT, the most common combinations

in CCS and EMC involve *EWSR1* exon 8 and exon 12, respectively. However, also in CCS and EMC, about ¼ of the cases show joining of exon 7. Additional, rare variants involving other *EWSR1* exons have been found.

Detailed molecular genetic analyses have shown that both of the two chimeric genes generated through a balanced translocation, i.e., 5'-geneA/3'-geneB and 5'-geneB/3'-geneA, may be transcribed. Available evidence strongly indicates that only one of the two fusion genes plays a major role in tumorigenesis. Whereas one transcript is invariably found, the other is only present in a subset of the tumors, and then often at levels that require nested PCR for detection. These observations are further supported by the cytogenetic findings (Figure 2). In cases where one of the two derivative chromosomes from a translocation has been lost it is always the same derivative chromosome that is retained, indicating the position of the pathogenetically important fusion gene. The same story is told by complex translocations involving 3 or more chromosomes.

Whereas much has been learnt about the molecular genetic consequences of sarcoma-associated translocations, little is known about the causes of these rearrangements. Investigations of the breakpoint junctions at the genomic level have demonstrated that breakage and reunion of DNA is often accompanied by more complex rearrangements; deletions, duplications, inversions or insertions of single or stretches of nucleotides are not uncommon. The search for sequence motifs in or in the vicinity of breakpoints that could explain the formation of translocations has not provided unambiguous information although some motifs that may promote recombination events have been identified (Panagopoulos et al. 1997). The preferential formation of some fusion gene variants may be explained by the 5'-3' orientation of genes on the chromosomes involved. This seems to be the case in MLS where a functional *FUS-DDIT3* fusion gene can be formed by a simple translocation, whereas additional rearrangements are required to obtain an in frame *EWSR1-DDIT3* chimeric gene. However, in EMC this is not a valid explanation for the finding of the skewed distribution of *EWSR1-NR4A3* and *TAF15-NR4A3*, respectively (Panagopoulos et al. 2002a).

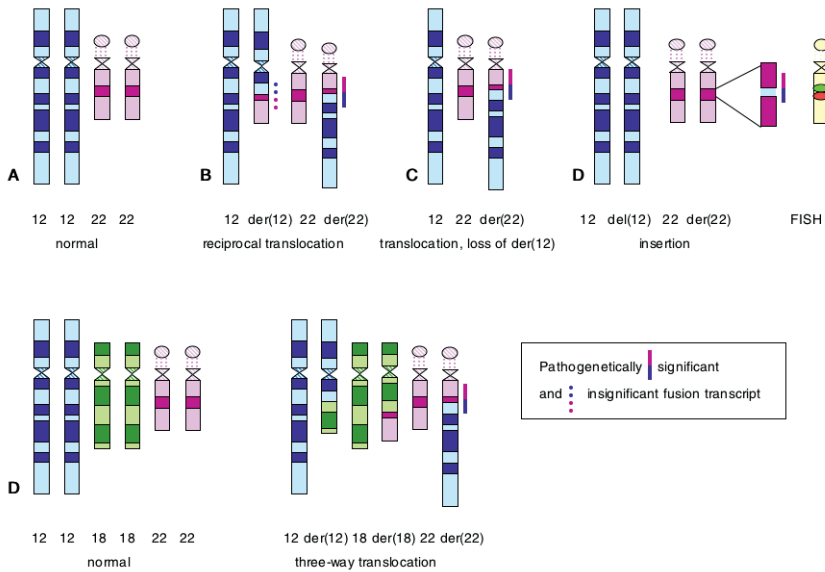

**Figure 2.** Illustration of different rearrangements giving rise to a fusion gene. **A)** normal chromosomes 12 and 22, **B)** balanced translocation resulting in the formation of two reciprocal fusion genes in the derivative chromosomes. Frequently only one of them is expressed (solid line). **C)** translocation followed by loss of the derivative chromosome 12. Only the pathogenetically significant chimeric transcript can be expressed. **D)** insertion of part of chromosome 12 into chromosome 22 resulting in the important fusion gene whose expression can be demonstrated by RT-PCR. By chromosome banding the chromosomes appear to be normal. Using differently labeled probes for the genes involved, the fusion can be demonstrated by FISH. **E,** Three-way-

The *HMGA2/LPP* fusion gene, resulting from a  $t(3;12)(q28;q15)$ , is an example of a rearrangement that is recurrent but not tumor-specific. It is a common aberration in ordinary lipoma, but has also been described in chondroma of soft tissue and pulmonary chondroid hamartoma (Petit et al. 1996; Rogalla et al. 2000; Dahlén et al. 2003). Another example of a characteristic but unspecific cytogenetic aberration is the occurrence of supernumerary ring chromosomes. This has been described, in karyotypes with few or no other aberrations, primarily among atypical lipomatous tumor (ALT), low grade malignant fibrous histiocytoma (MFH), DFSP, LGFS and parosteal osteosarcoma (POS) (Örndal et al. 1992; Szymanska et al. 1996; Panagopoulos et al. 2004). The identification of these rings long remained a challenge. Their composition has been resolved by FISH and molecular genetic analyses, which have shown that the cytogenetic similarity is, at least to some extent, illusory. In ALT, rings regularly contain material from the long arm of chromosome 12 (12q), but frequently also from other chromosomes, in

particular chromosome 1 (Pedeutour et al. 1999; Meza-Zepeda et al. 2001). Also in POS and MFH, rings containing chromosome 12-sequences have been described. The mechanism of ring formation is unknown, but it has been shown that these mitotically unstable structures constantly reshape through breakage-fusion-bridge cycles, which is an effective mechanism for both loss and amplification of genes (Gisselsson et al. 1999, 2000). Practically without exceptions, the *MDM2* gene is included among the amplified sequences. In DFSP, the rings are constructed in another way, which seems to represent a conceptually different genetic mechanism of tumorigenesis. Material from chromosomes 17 and 22 are included in the rings, and the rearrangements of these chromosomes result in a *COL1A1/PDGFB* fusion gene. Occasionally, instead of a  $r(17;22)$  a reciprocal translocation,  $t(17;22)(q22;q13)$ , is seen. The mitotic instability of the rings results in at least low-level amplification of 17q and 22q sequences (Sirvent et al. 2003). A similar situation exists in LGFS where a *FUS/BBF2H7* fusion gene is manifested cytogenetically

either as a balanced or unbalanced t(7;16) or as a supernumerary ring chromosome (Panagopoulos et al. 2004).

The secondary chromosome aberrations in tumors with specific translocations are clearly nonrandom. Many of these aberrations are shared by several tumor types with different primary changes, but the pattern is by no means uniform for all of them. In particular, chromosomes 7, 8 and 12 are frequently involved in numerical changes. Gain of chromosome 8 is seen at frequencies ranging from 67% to 10% in CCS, ES, DFSP, EMC, MLS and SS, respectively, but is rare in ARMS (Mitelman Database of Chromosome Aberrations in Cancer 2003). Extra copies of chromosome 12 are common in ES, ARMS, EMC and SS (20–15%), whereas gain of chromosome 7 is preferentially found among CCS, EMC, SS and ES (38–8%). As for chromosome losses, the pattern is more scattered and the frequencies are lower. Chromosomes 3, 6, 10, 14 and 16 are most frequently involved. The localization of breakpoints of structural rearrangements differs between different tumor types, except for most types showing a clustering of breaks at 1p and/or 1q. Unbalanced 1;16-translocations, often resulting in gain of 1q and loss of 16q, are frequently found in ES and ARMS, but also in MLS, as well as in a variety of other neoplasms. There is a distinct difference in the average number of secondary changes among tumor types, ranging from about 1.5 in MLS to 2 for DFSP, 3–3.5 for EMC and ES, 4–4.5 for SS and ARMS and 7 for CCS. Thus, some of these tumor types seem, for unknown reasons, to be more prone to acquire additional aberrations.

Yet another group of tumors is characterized by complex, mostly unbalanced structural and/or numerical chromosome aberrations, and seemingly lacks specific translocations. This is seen in, for example, pleomorphic liposarcoma, leiomyosarcoma, high-grade MFH, malignant peripheral nerve sheath tumor, osteosarcoma and, to some extent, in chondrosarcoma and embryonal rhabdomyosarcoma. Typically, there is an extensive cytogenetic heterogeneity, sometimes with almost no two cells displaying identical chromosome complements, indicating a marked genetic instability. Usually, there is a core of aberrations seen in all metaphase cells; other aberrations are detected

at varying clonal proportions, whereas still other changes are seemingly non-clonal. Despite this disparate cytogenetic picture, investigation of larger series of tumors of a particular histotype and review of literature data clearly show that there is some nonrandomness as regards breakpoint localization as well as losses and gains of chromosome segments. Many of the imbalances are shared by different subtypes of BSTT, but also by several epithelial tumors. Cytogenetic signs of gene amplification, i.e., double minutes (dmin) and homogeneously staining regions (hsr), are particularly common in this group of tumors, with frequencies at about 10–20% of the cases. This is in sharp contrast to tumors characterized by specific translocations where such gene amplification is rare; an exception is ARMS with t(1;13), which displays dmin or hsr in 10–15% of the cases.

Most sarcomas contain multiple copy number changes, especially gains and amplifications, detectable by chromosomal CGH ([http://www.helsinki.fi/cm/cgh\\_data.html](http://www.helsinki.fi/cm/cgh_data.html); Tarkkanen and Knuutila 2002). Although most of these imbalances are secondary in nature and present not only in several BSTTs but also in other malignancies, some of the amplicons are restricted to certain sarcoma subtypes. For some common, recurrent amplicons, candidate target genes have been identified (Table 1). Recent CGH microarray analyses indicate that there are numerous smaller, novel amplicons that have passed undetected by chromosome CGH (Knuutila 2004). These microarray results have provided evidence that large chromosomal amplicons actually include separate subamplicons, and that the target genes are different in different sarcoma subtypes.

### *Diagnosis and prognosis*

With the delineation of karyotypic patterns in BSTTs, it has become clear that genetic analyses provide significant diagnostic information. Furthermore, for some tumor types the number of investigated cases has been large enough to allow attempts to identify genetic factors that may be used to increase the prognostic precision. As regards the tumor-specific balanced aberrations, the cytogenetic detection of translocations is quite helpful for confirmation of a suspected diagnosis or sometimes to suggest an alternative diagnosis.

Table 1. Common, recurrent amplicons and candidate target genes identified among BSTTs

Amplicon	Target gene	Tumor <sup>a</sup>	Clinical features
1q21-23	FLG, SPRR1, SPRR2, SPRR3, S100A6, COAS1, COAS2, COAS3	OS, LS, LMS, ET	Poor prognosis?
8p23	MFHAS1	MFH	
8q23-24	MYC	Various	Poor prognosis
12q13-15	MDM2, SAS, DDIT3, GLI, HMGA2, LRP1	LS, ARMS, SS, ET, OS	
17p	Under study	OS, LMS	
17q	TOP2A	MPNST	Treatment response?
17q and 22q	Under study	DFSP	

<sup>a</sup> Abbreviations: OS osteosarcoma, LS liposarcoma, LMS leiomyosarcoma, ET Ewing tumor, MFH malignant fibrous histiocytoma, ARMS alveolar rhabdomyosarcoma, SS synovial sarcoma, MPNST malignant peripheral nerve sheath tumor, DFSP dermatofibrosarcoma protuberans.

Also, the presence of characteristic, but non-specific, chromosome aberrations may, together with clinical and histopathologic data, add to the diagnostic accuracy. In contrast, the prognostic power of cytogenetic aberration patterns is negligible; alternative translocations associated with a particular tumor type do not seem to have any predictive value, and the impact of secondary chromosome changes, which may be seen as a sign of tumor progression through clonal evolution, is still unclear. However, preliminary data suggest that loss of distal 1p may be associated with unfavorable outcome in ET (Hattinger et al. 1999), that loss of 13q sequences may be an independent prognostic factor for metastasis in chondrosarcoma (Mandahl et al. 2002), and that breakpoints in chromosome regions 1p1, 1q4, 14q1, and 17q2 and gain of 6p sequences may be associated with increased risk of metastasis in high-grade soft tissue sarcomas (Mertens et al. 2002).

The situation is different and more promising when it comes to the molecular genetic characterization of fusion genes. For example, several studies have shown that the type of fusion gene is associated with clinical outcome in patients with synovial sarcoma (Ladanyi et al. 2002, and references therein). Patients with the *SS18-SSX2* fusion gene had significantly better median and 5-year overall survival than patients with the *SS18-SSX1* variant. Another study where both cytogenetic and molecular genetic analyses had been performed on the same tumors, concluded that the type of gene fusion is a better indicator of clinical outcome than is the tumor karyotype (Panagopoulos et al. 2001).

Similar findings have been reported for ET; the most common transcript, which is found in about 60% of the cases, and that joins *EWSR1* exons 1–7 with *FLII* exons 6–9, is associated with better prognosis than other fusions of *EWSR1* with *FLII* or other genes (e.g., de Alava et al. 1998). This correlation is further corroborated by the finding that alternative chimeric proteins show different transactivation capacities in vitro (Lin et al. 1999). Among patients presenting with metastatic ARMS, the type of fusion gene seems to be useful to identify high-risk patients and patients with favorable outcome (Sorensen et al. 2002). In contrast, no predictive value of fusion transcript type could be demonstrated in MLS (Antonescu et al. 2001).

Hopefully, continued detailed mapping and characterization of genetic changes of BSTTs will provide essential information that can be used clinically. Most likely, new gene fusions, variant transcripts, point mutations, loss and amplification of genes will be identified. It can be expected that CGH microarray will allow a more precise identification of the target genes in amplicons containing multiple genes. These data, alone or in combination with expression analyses and functional studies, could be the basis for improved diagnosis and prognostication and may reveal molecular targets for tailored treatments.

Åman P, Panagopoulos I, Lassen C, Fioretos T, Mencinger M, Toresson H, Höglund M, Forster A, Rabbitts TH, Ron D, Mandahl N, Mitelman F. Expression patterns of the human sarcoma-associated genes FUS and EWS and the genomic structure of FUS. *Genomics* 1996; 37: 1-8.

- Åman P. Fusion genes in solid tumors. *Sem Cancer Biol* 1999; 9: 303-18.
- Antonescu CR, Tschernyavsky SJ, Decuseara R, Leung DH, Woodruff JM, Brennan MF, Bridge JA, Neff JR, Goldblum JR, Ladanyi M. Prognostic impact of P53 status, *TLS-CHOP* fusion transcript structure, and histological grade in myxoid liposarcoma: A molecular and clinicopathologic study of 82 cases. *Clin Cancer Res* 2001; 7: 3977-87.
- Dahlén A, Mertens F, Rydholm A, Brosjö O, Wejde J, Mandahl N, Panagopoulos I. Fusion, disruption and expression of *HMG2* in bone and soft tissue chondromas. *Mod Pathol* 2003; 16: 1132-40.
- de Alava E, Kawai A, Healey JH, Fligman I, Meyers PA, Huvos AG, Gerald WL, Jhanwar SC, Argani P, Antonescu CR, Pardo-Mindan FJ, Ginsberg J, Womer R, Lawlor ER, Wunder J, Andrulis I, Sorensen PHB, Ladanyi M. *EWS-FLI1* fusion transcript structure is an independent determinant of prognosis in Ewing's sarcoma. *J Clin Oncol* 1998; 16: 1248-55.
- Fletcher CDM, Unni KK, Mertens F (eds.): World Health Organization Classification of Tumours. Pathology and Genetics of Tumours of Soft Tissue and Bone. Lyon, IARC Press, 2002.
- Gisselsson D, Höglund M, Mertens F, Johansson B, Dal Cin P, Van den Berghe H, Earnshaw WC, Mitelman F, Mandahl N. The structure and dynamics of ring chromosomes in human neoplastic and non-neoplastic cells. *Hum Genet* 1999; 104: 315-25.
- Gisselsson D, Pettersson L, Höglund M, Heidenblad M, Gorunova L, Wiegant J, Mertens F, Dal Cin P, Mitelman F, Mandahl N. Chromosomal breakage-fusion-bridge events cause genetic intratumor heterogeneity. *Proc Natl Acad Sci (USA)* 2000; 97: 5357-62.
- Hattinger CM, Rumpel S, Strehl S, Ambros IM, Zoubek A, Pötschger U, Gadner H, Ambros PF. Prognostic impact of deletions at 1p36 and numerical aberrations in Ewing tumors. *Genes Chromosomes Cancer* 1999; 24: 243-54.
- Knuutila S. Cytogenetics and molecular pathology in cancer diagnostics. *Ann Med* 2004; in press.
- Ladanyi M, Antonescu CR, Leung DH, Woodruff JM, Kawai A, Healey JH, Brennan MF, Bridge JA, Neff JR, Barr FG, Goldsmith JD, Brooks JSJ, Goldblum JR, Ali SZ, Shipley J, Cooper CS, Fisher C, Skytting B, Larsson O. Impact of *SYT-SSX* fusion type on the clinical behavior of synovial sarcoma: A multi-institutional retrospective study of 243 patients. *Cancer Res* 2002; 62: 135-40.
- Lin PP, Brody RI, Hamelin AC, Bradner JE, Healey JH, Ladanyi M. Differential transactivation by alternative *EWS-FLI1* fusion proteins correlates with clinical heterogeneity in Ewing's sarcoma. *Cancer Res* 1999; 59: 1428-32.
- Mandahl N, Gustafson P, Mertens F, Åkerman M, Baldetorp B, Gisselsson D, Knuutila S, Bauer HCF, Larsson O. Cytogenetic aberrations and their prognostic impact in chondrosarcoma. *Genes Chromosomes Cancer* 2002; 33: 188-200.
- Mertens F, Strömberg U, Mandahl N, Dal Cin P, De Wever I, Fletcher CDM, Mitelman F, Rosai J, Rydholm A, Sciot R, Tallini G, Van den Berghe H, Vanni R, Willén H. Prognostically important chromosomal aberrations in soft tissue sarcomas: A report of the Chromosomes and Morphology (CHAMP) Study Group. *Cancer Res* 2002; 62: 3980-4.
- Meza-Zepeda LA, Berner J-M, Henriksen J, South AP, Pedetour F, Dahlberg AB, Godager LH, Nizetic D, Forus A, Myklebost O. Ectopic sequences from truncated *HMGIC* in liposarcomas are derived from various amplified chromosomal regions. *Genes Chromosomes Cancer* 2001; 31: 264-73.
- Mitelman Database of Chromosome Aberrations in Cancer, 2003. Mitelman F, Johansson B, Mertens F (eds.). <http://cgap.nci.nih.gov/Chromosomes/Mitelman>
- Örndal C, Mandahl N, Rydholm A, Willén H, Brosjö O, Heim S, Mitelman F. Supernumerary ring chromosomes in five bone and soft tissue tumors of low or borderline malignancy. *Cancer Genet Cytogenet* 1992; 60: 170-5.
- Panagopoulos I, Lassen C, Isaksson M, Mitelman F, Mandahl N, Åman P. Characteristic sequence motifs at the breakpoints of the hybrid genes *FUS/CHOP*, *EWS/CHOP* and *FUS/ERG* in myxoid liposarcoma and acute myeloid leukemia. *Oncogene* 1997; 15: 1357-62.
- Panagopoulos I, Mertens F, Isaksson M, Mandahl N. A novel *FUS/CHOP* chimera in myxoid liposarcoma. *Biochem Biophys Res Commun* 2000; 279: 838-45.
- Panagopoulos I, Mertens F, Isaksson M, Limon J, Gustafson P, Skytting B, Åkerman M, Sciot R, Dal Cin P, Samson I, Iliszko M, Ryoe J, Dêbiec-Rychter M, Szadowska A, Brosjö O, Larsson O, Rydholm A, Mandahl N. Clinical impact of molecular and cytogenetic findings in synovial sarcoma. *Genes Chromosomes Cancer* 2001; 31: 362-72.
- Panagopoulos I, Mertens F, Isaksson M, Domanski HA, Brosjö O, Heim S, Bjerkehagen B, Sciot R, Dal Cin P, Fletcher JA, Fletcher CDM, Mandahl N. Molecular genetic characterization of the *EWS/CHN* and *RBP56/CHN* fusion genes in extraskeletal myxoid chondrosarcoma. *Genes Chromosomes Cancer* 2002a; 35: 340-52.
- Panagopoulos I, Mertens F, Debiec-Rychter M, Isaksson M, Limon J, Kardas I, Domanski HA, Sciot R, Perek D, Crnalic S, Larsson O, Mandahl N. Molecular genetic characterization of the *EWS/ATF1* fusion gene in clear cell sarcoma of tendons and aponeuroses. *Int J Cancer* 2002b; 99: 560-7.
- Panagopoulos I, Storlazzi CT, Fletcher CDM, Fletcher JA, Nascimento A, Domanski HA, Wejde J, Brosjö O, Rydholm A, Isaksson M, Mandahl N, Mertens F. The chimeric *FUS/BBF2H7* gene is specific for low grade fibromyxoid sarcoma. *Genes Chromosomes Cancer* 2004; in press.
- Pedetour F, Forus A, Coindre J-M, Berner J-M, Nicolo G, Michiels J-F, Terrier P, Ranchere-Vince D, Collin F, Myklebost O, Turc-Carel C. Structure of the supernumerary ring and giant rod chromosomes in adipose tissue tumors. *Genes Chromosomes Cancer* 1999; 24: 30-41.
- Petit MMR, Schoenmakers EFPM, Huysmans C, Geurts JMW, Mandahl N, Van de Ven WJM. *LPP*, the preferred fusion partner gene of *HMGIC* in lipomas, is a novel member of the LIM protein gene family. *Genomics* 1996; 36: 118-29.



- Rogalla P, Lemke I, Kazmierczak B, Bullerdiek J. An identical HMGIC-LPP fusion transcript is consistently expressed in pulmonary chondroid hamartomas with t(3;12)(q27-28;q14-15). *Genes Chromosomes Cancer* 2000; 29: 363-6.
- Sirvent N, Maire G, Pedeutour F. Genetics of dermatofibrosarcoma protuberans family of tumors: From ring chromosomes to tyrosine kinase inhibitor treatment. *Genes Chromosomes Cancer* 2003; 37: 1-19.
- Sorensen PH, Lynch JC, Qualman SJ, Tirabosco R, Lim JF, Maure HM, Bridge JA, Crist WM, Triche TJ, Barr FG. *PAX3-FKHR* and *PAX7-FKHR* gene fusion are prognostic indicators in alveolar rhabdomyosarcoma: A report from the children's oncology group. *J Clin Oncol* 2002; 20: 2672-79.
- Szymanska J, Mandahl N, Mertens F, Tarkkanen M, Karaharju E, Knuutila S. Ring chromosomes in parosteal osteosarcoma contain sequences from 12q13-15: A combined cytogenetic and comparative genomic hybridization study. *Genes Chromosomes Cancer* 1996; 16: 31-4.
- Tarkkanen M, Knuutila S. The diagnostic use of cytogenetic and molecular genetic techniques in the assessment of small round cell tumours. *Current Diagn Pathol* 2002; 8: 338-48.