



LUND UNIVERSITY

Echo glottography ultrasonic recording of vocal fold vibrations in preparations of human larynges

Kitzing, Peter; Holmer, Nils-Gunnar; Lindström, Kjell

Published in:
Acta Oto-Laryngologica

DOI:
[10.3109/00016487309139775](https://doi.org/10.3109/00016487309139775)

1973

[Link to publication](#)

Citation for published version (APA):

Kitzing, P., Holmer, N.-G., & Lindström, K. (1973). Echo glottography ultrasonic recording of vocal fold vibrations in preparations of human larynges. *Acta Oto-Laryngologica*, 75(2-6), 454-463.
<https://doi.org/10.3109/00016487309139775>

Total number of authors:
3

General rights

Unless other specific re-use rights are stated the following general rights apply:
Copyright and moral rights for the publications made accessible in the public portal are retained by the authors and/or other copyright owners and it is a condition of accessing publications that users recognise and abide by the legal requirements associated with these rights.

- Users may download and print one copy of any publication from the public portal for the purpose of private study or research.
- You may not further distribute the material or use it for any profit-making activity or commercial gain
- You may freely distribute the URL identifying the publication in the public portal

Read more about Creative commons licenses: <https://creativecommons.org/licenses/>

Take down policy

If you believe that this document breaches copyright please contact us providing details, and we will remove access to the work immediately and investigate your claim.

LUND UNIVERSITY

PO Box 117
221 00 Lund
+46 46-222 00 00

ECHO GLOTTOGRAPHY

Ultrasonic Recording of Vocal Fold Vibrations in Preparations of Human Larynges

N.-G. Holmer, P. Kitzing and K. Lindström

From the Department of Electrical Measurements, Lund Institute of Technology, Lund, and the Department of Phoniatics, University ENT-Clinic, General Hospital, Malmö, Sweden

(Received April 11, 1972)

Abstract. Except for the entirely subjective stroboscopy there is no generally accepted clinical method for continuous recording of vocal fold vibrations. In laryngology and phoniatics it is therefore usually difficult to assess vocal fold function objectively. Echoglottography, however, an ultrasonic pulse-echo method for the study of the vibrating vocal folds, meets many of the necessary requirements.

For the recording of vocal fold vibrations a special, highly sensitive ultrasound reflectoscope has been constructed, allowing the use of transducers with different ultrasound frequencies. A pulse repetition frequency of 10 kHz was chosen, sufficient for continuous recording of fast vibratory movements, yet giving an adequate recording depth. In initial experiments an ultrasound frequency of 4 MHz was shown to penetrate even ossified cartilages, this frequency being high enough for high longitudinal and lateral resolution of the ultrasound beam.

As a basis for the development of an echoglotto-graphic method the ultrasound echoes from laryngeal specimens have been recorded. Echoes from the free margin of the vocal folds could be demonstrated and unequivocally identified. Vibrations in these same structures gave rise to characteristic curves, resembling glottograms recorded with other, less convenient methods.

The vibratory pattern of the human vocal folds during phonation is of great interest in laryngeal physiology as well as in clinical laryngology. Because of their high frequency, the vibrations of the folds cannot be visualized

The investigation was supported in part by grants from Swedish Medical Research Council (Project K70-14X-3021-01A) and Swedish Board for Technical Development (Project 70-1364/U1033b).

directly, but during recent decades several methods have come into use to overcome this obstacle. However, since all of these more or less indirect methods have certain drawbacks, none of them has been generally adopted in clinical routine work at departments of laryngology.

The commonest clinical method is synchronostroboscopy, described in detail by Schönhärl (1960). It provides no objective recording but is entirely dependent on the investigator's subjective impression of slow motion, which appears when the human eye observes very short flashed images from consecutive vibratory cycles, and no continuous recording of the vibrations can be made. A great deal of research work on laryngeal physiology has been done with high speed film technique, first described by Farnsworth (1940), but in spite of isolated reports to the contrary (Teter et al., 1969), it must be said to be too expensive and too space- and time-consuming for use in clinical routine. Besides, the employment of a fixed laryngeal mirror as part of this method demands a great deal of cooperation from the subject.

Untrained patients, who, in addition, may present pharynx and larynx with narrow anatomy, are therefore difficult to photograph.

A comparatively easy way to record the

continuous variations of the glottal area during phonation is by photoelectric glottography (Sonesson, 1960). By this method, the intensity variations of a transilluminated light beam directed through the glottis are recorded and visualized as a curve on a cathode ray oscilloscope. However, the method does not allow conclusions concerning the vibratory movements of one single vocal fold, and some authors have pointed out that it yields insufficient information about certain parts of the vibratory cycle (Köster & Smith, 1970).

In electroglottography, described by Fabre (1957), the impedance variations in the tissues of the neck are recorded during phonation. Because of variations in tissue impedance not dependent on vocal fold movements, this method involves a considerable risk of artefacts interfering with recording (Frøkjær-Jensen, 1969).

In studies of laryngeal function many investigators have used acoustic analyses of the emitted voice, such as sound spectrography (Nessel, 1962; Yanagihara, 1962, 1967) or inverse filtering (Fant, 1961). In addition to other disadvantages of these methods in clinical work, only limited conclusions can be drawn from them as regards the vibratory pattern of each vocal fold.

It is obvious from these introductory remarks that an ultrasonic method for recording of vocal fold vibrations would be very convenient in clinical laryngology and phoniatrics, and it would also be very comfortable for the patient. The recording would be continuous, direct and objective—a combination not possible to achieve by any other single method. Besides, it would be possible to develop the method by using two transducers covering both vocal folds simultaneously.

The first to present an ultrasonic recording of a vibrating vocal fold was probably Mensch in 1964. Unfortunately, his traces do not allow any analysis of the vibratory movements involved. In two almost identical papers Kitamura et al. (1968) have published very interesting recordings, and their forthcoming

more detailed report is eagerly looked forward to. Hertz et al. (1970) have presented a preliminary report on vocal fold recordings, prepared at our laboratory with an apparatus originally devised for echocardiography. This type of apparatus has a pulse repetition frequency of 1 000 Hz, which is not high enough to produce clinically usable recordings of vocal fold vibrations with a frequency of 100 Hz or more.

Therefore, an ultrasonic reflectoscope has been constructed with a pulse repetition frequency of 10 000 Hz, which has proved to give satisfactory recordings of vocal fold vibrations. An outline of this new apparatus is given below. Technical details will be given in a special report to be published later.

PHYSICAL PROPERTIES OF ULTRASOUND

Before the technical data and the application of the ultrasonic echo method for studying the vibrating vocal folds are described, a very short description of the physical properties of ultrasound will be presented below and illustrated in Fig. 1. For more detailed information the reader is referred to Hertz (1967).

Reflection

When a plane acoustic wave travelling in a medium impinges upon a boundary of a second medium, part of the wave is reflected into the first medium. The reflected sound intensity, I , resulting from a sound beam of intensity, I_0 , falling perpendicularly on a flat surface, is represented by

$$I = I_0 \left(\frac{\rho_1 v_1 - \rho_2 v_2}{\rho_1 v_1 + \rho_2 v_2} \right)^2$$

where ρ and v are densities and sound velocities in two media on each side of a reflecting boundary (see Fig. 1 *a*). As the larynx is filled with air having an acoustic impedance, ρv , which is much smaller than the surrounding tissues, strong reflection from the boundary vocal fold vs. air is to be expected.

Absorption

The absorption of ultrasound is considerable in biological tissue. If a parallel ultrasound beam travels through a certain medium the intensity of the beam decreases along the beam according to the relation

$$I = I_0 e^{-2kfx}$$

where k is a constant depending on the biological substance, f the sound frequency and x the distance covered by the sound wave in the medium. This phenomenon is illustrated in Fig. 1 b. It appears from this that ultrasound of very high frequency is too much absorbed to be of practical use.

Diffraction

An ultrasound beam, like any wave motion, diverges because of diffraction. In the well-known Fraunhofer diffraction formula, $\sin \varphi = 0.61 \lambda/\alpha$, the angle φ is the divergence angle, λ is the wavelength of sound and α the radius of a circular transducer. From this it is obvious that the use of a very high frequency (short wave length, λ) will result in a small diffraction angle and thus in a well defined beam. The diffraction is illustrated in Fig. 1 c. It is important to notice that a small transducer may generate a poorly defined beam with a high divergence angle.

Angle error

If the reflecting surface is not perpendicular to the transmitter a great deal or all of the transmitted sound will not be reflected back to the transducer, Fig. 1 d.

METHOD

Technical principles

The ultrasonic pulse echo method is used for recording of vocal fold vibrations. The movements of the ultrasound echoes are recorded by the time motion (TM) technique well known from echocardiography. Fig. 2 shows the principle of the time motion technique: A

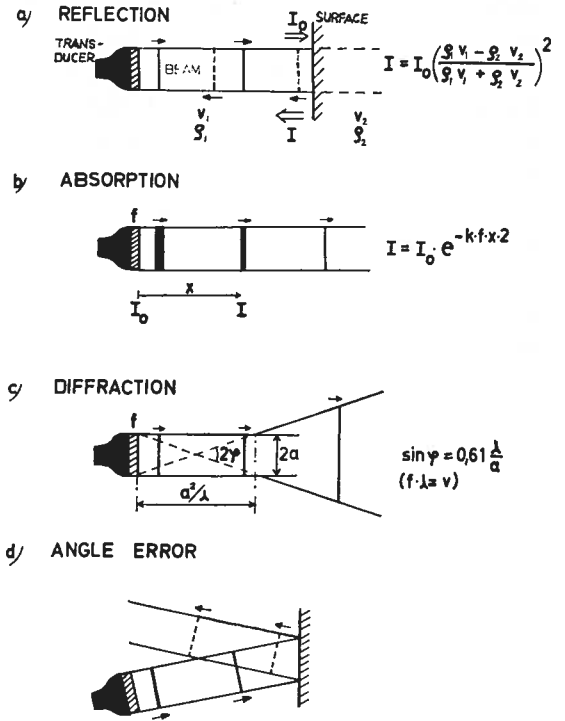

Fig. 1. Physical properties of ultrasound. —, transmitted ultrasound pulse; ---, reflected ultrasound pulse. (a) Reflection of ultrasound beam towards a surface where ρ and v are densities and sound velocities in two media on each side of a reflecting boundary. (b) Absorption of ultrasound, where k is a constant depending on the biological tissue, f the sound frequency and x the distance covered by the sound. (c) Diffraction of an ultrasound beam. In the formula φ is the angle of divergence, λ the wavelength of sound in the medium and α the radius of a circular transducer. (d) Angle error. Loss of echo when beams do not strike reflecting surface at right angles.

saw tooth voltage generated from the ultrasound reflectoscope deflects the electron beam in a cathode ray tube (CRT), along the negative y-axis for every transmitted ultrasound pulse. At the same time, the intensity of the electron beam in the CRT is modulated by the echo signal from the reflectoscope in such a way that it appears on the CRT-screen only when an echo is received. If the time base (x-axis) of the cathode ray oscilloscope runs at a suitable slow deflection speed, the movements of the vocal fold echoes can immediately be observed on the screen. For

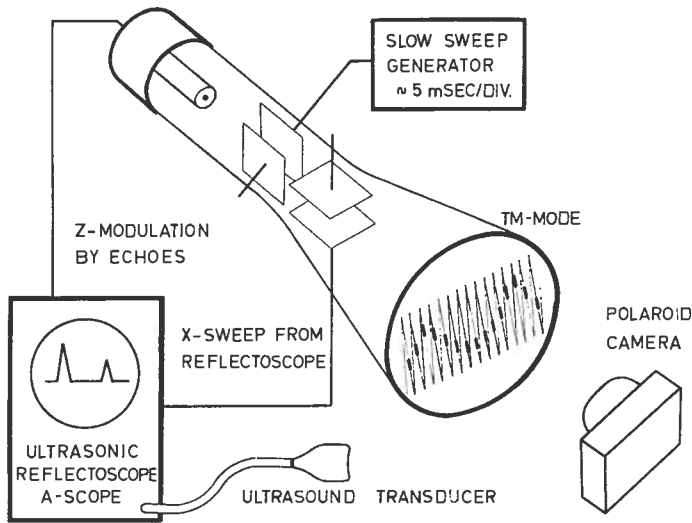

Fig. 2. Principal diagram of the TM-recording method in which the echo-glottographic recording of the vibrating vocal folds are directly displayed on the screen of a cathode ray tube and photographed with a Polaroid camera.

registration and filing the CRT-screen is photographed with a polaroid camera.

Reflectoscope

As mentioned above, commercial ultrasound reflectoscopes with a pulse repetition frequency of 50–1 000 Hz are useless because of the rapid vibratory movements of the vocal folds. Therefore the new ultrasound reflectoscope was built so as to yield a pulse repetition frequency of 10 000 Hz and was especially adapted for recording of the movements of the vocal folds. A block diagram of the apparatus is shown in Fig. 3.

The reflectoscope consists fundamentally of five blocks. The first block, a 10 kHz clock-pulse generator, controls the function of the following three blocks: sweep-generator, transmitter and depth compensation generator. The fifth block is the receiver unit with inputs from the transducer and the depth compensation generator and an output to the oscilloscope (TEK. 549) on which the TM-display is obtained. For control purposes, an A-scope display is achieved on a separate monitor oscilloscope.

The 10 kHz clock triggers the transmitter, which generates 300 V pulses for the ultrasound transducer of only 1.0 μ sec duration.

This has the advantage of permitting the connection of transducers of different sizes and ultrasound frequency.

The 10 kHz clock also initiates the sweep generator, which generates a saw tooth voltage each time an ultrasound pulse is transmitted. The start as well as the slope of the sweep can be adjusted. This makes it possible to select and magnify interesting echoes for TM-display.

By the depth compensation generator losses due to ultrasound absorption in tissue can be neutralized within wide ranges.

The preamplifier of the receiver consists of five cascode amplifiers (Valley & Wallman, 1948) with overload protections. Cascode amplifiers have been chosen because of their excellent ability to amplify signals of very high frequency. The gain of this preamplifier is controlled by the depth compensation generator. Field effect transistors located near the cascode circuits adjust the gain of the receiver. They are operated by remote control which prevents the risk of undesirable oscillations.

For rectification, a new high-sensitive full-wave detector has been constructed. The rectified intensity modulation signal is transferred from a low impedance source via a coaxial cable to an amplifier placed immediately at

the cathode ray oscilloscope. This eliminates signal losses in the coaxial cable.

For TM representation of the vocal fold movements a storage oscilloscope is used. Because of the very high writing speed necessary, a Tektronix 549 storage oscilloscope had to be chosen. The auto erase function of this CRO also makes it possible to discard less interesting echoglottograms, which saves time and film costs.

Depending on the fundamental frequency of the vocal fold vibrations (100–200 Hz) the time base of the oscilloscope is used at a deflection speed of 1–10 msec/div.

The small size of the vibratory movements of the vocal folds puts the apparatus' capacity for resolution to a severe test. The present equipment has experimentally been shown to measure correctly movements of 0.1 mm and less.

As the pulse repetition frequency is as high as 10 000 Hz, the silent period between two consecutive pulses has a duration of only 100 μ sec. This is the time in which returning echoes must be received. As the sound velocity in the tissues is about 1 500 m/sec. the maximum recording depth is calculated at somewhat more than 7 cm. At higher pulse repetition frequencies the recording depth decreases and there is a risk of receiving ghost echoes from earlier pulses.

Transducer

To be able to resolve the complex movements of the vocal folds, a very narrow ultrasonic beam must be used. Therefore the crystal must be selected with great care. A large crystal produces too wide a beam, a small crystal a beam of increasing angle of divergence. These problems are discussed extensively by Edler (1961). As one solution, ultrasound of as high a frequency as possible has been used, the frequency being limited by the sound absorption. Transducers with the frequencies 2, 4 and 6 MHz have been tested.

The transducer crystal is made of a ceramic material which converts an electrical voltage

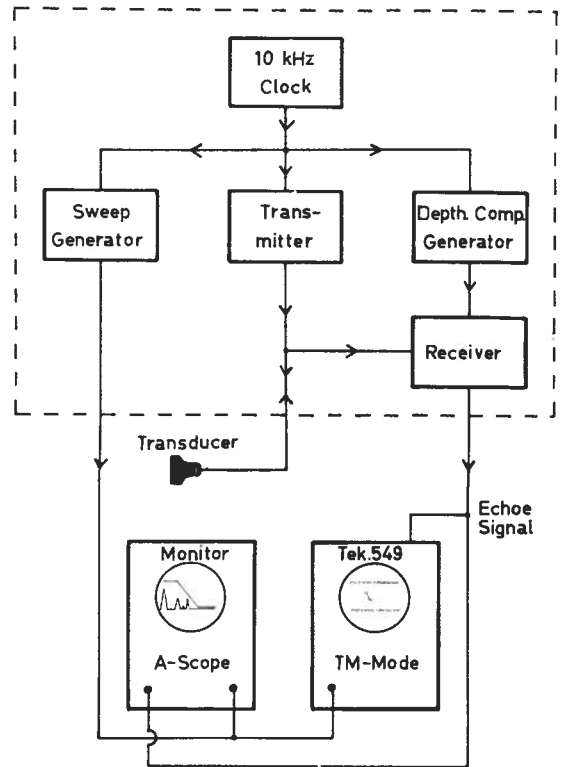

Fig. 3. Block diagram of especially constructed reflectoscope for echoglossography, including a monitor oscilloscope for A-scope and a storage oscilloscope for TM-display.

into sound pressure (pulse transmitter), and sound pressure to an electrical voltage (echo receiver). The material in the transducer (Brush Clevite PZT: 5A), a modified lead zirconate titanate, strikes a mean between transmitting efficiency and receiving sensitivity for the transducer, together with a relatively high mechanical damping. To prevent the transducer from "ringing", it is necessary to mount the ceramic bowl or dish on a backing material which will increase the damping of the disc appreciably. This backing material consists of fine tungsten powder imbedded in Araldite resin, which efficiently scatters and absorbs the sound transmitted into it. The amount of tungsten powder is chosen in such a way that the acoustic impedance of the material is about the same as that required by the transducer to reach optimum damping.

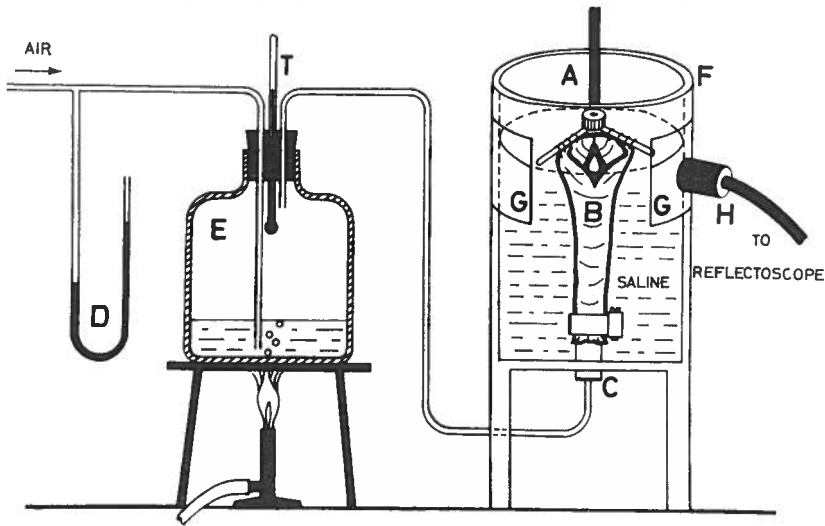

Fig. 4. Arrangement of experiments. Moist and heated air passes through the trachea of a laryngeal preparation suspended in a saline-filled vessel with windows for the transducer.

With this transducer and external electrical damping it is possible to achieve sound pulses as short as 1 μ sec at 4 MHz.

Arrangement of experiments

In preliminary experiments ultrasound penetration of human thyroid cartilage with varying degree of ossification was compared with roentgenograms.

The arrangement shown in Fig. 4 was used for the principal part of our work. On a fork-like stand (A) the upper part of a human larynx preparation (B) was fixed, so that the

trachea was suspended vertically and could be connected to a plastic tube (C) for humidified and heated air (E). The temperature and pressure of the air could be measured by a thermometer (T) and a water-manometer (D) respectively. At certain air pressures and by manipulation of the laryngeal cartilages the vocal folds of the larynx preparation could be made to vibrate, emitting sounds of different pitch and quality. The larynx preparation was inserted into a circular perspex tank (F) with physiological saline or water. Windows (G) were cut in the tank and covered with a thin rubber membrane for application of the ultrasound transducer (H).

The experimental arrangements were made according to the principles developed by van den Berg et al. (1959).

RESULT

The ability of ultrasound to penetrate cartilage with varying degree of ossification was studied by measuring the amplitude attenuation at different frequencies. The results are shown in Table I. Measurements were made at the anterior edge and at the centre of four equally thick thyroid laminae varying in age and sex. The attenuation proved to be in good agree-

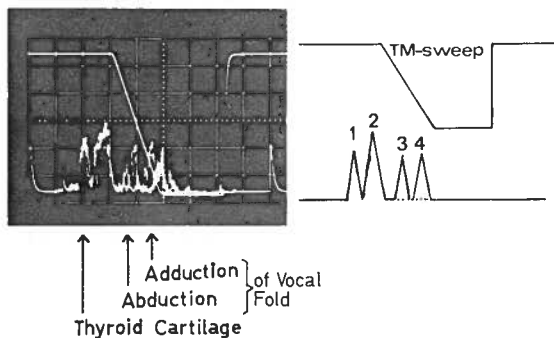

Fig. 5. Ultrasound registration of manipulations with a vocal fold. A-scope. Double exposure with representation of the echoes from the same vocal fold in abducted and adducted position respectively. 1, External lamina; 2, internal lamina of thyroid cartilage; 3, vocal fold in abduction; 4, vocal fold in adduction.

Table I. Attenuation of ultrasound intensity due to absorption in thyroid laminae (measured in dB = $-10 \log I_0/I$)

Age/Sex ...	83/male		43/male		75/female		63/female	
	Anterior edge (-dB)	Centre (-dB)	Anterior edge (-dB)	Centre (-dB)	Anterior edge (-dB)	Centre (-dB)	Anterior edge (-dB)	Centre (-dB)
2	30	6	36	18	10	4	23	6
4	36	16	40	19	20	6	26	10
6	^a	26	^a	21	25	11	29	16

^a Very high absorption, not measurable with the technique used.

ment with the ossification as it appeared on an X-ray from the cartilages. As expected from textbook information about the progression of larynx ossification due to age and sex (e.g. Lanz & Wachsmuth, 1955), absorption was shown to be least in the central part of the thyroid cartilage.

The human vocal folds are comparatively small structures: the size of their lateral excursion during vibration is often less than 1 mm. Therefore the best possible resolution is demanded from the ultrasonic apparatus. This can be achieved with ultrasound of high frequency. But, as pointed out earlier, the higher the frequency the greater the absorption, and there is a frequency limit when it becomes impossible to penetrate the tissues under investigation.

In our experiments the sound beam was in some cases practically entirely absorbed by the thyroid cartilage at a frequency of 6 MHz. The ultrasound frequency of 4 MHz was found to be the highest possible for experiments with larynx preparations, and the present work was carried out mainly with a transducer of this frequency.

At the beginning the experiments with

larynx preparations were carried out without vibrations of the vocal folds. An echo representing the inner and outer surface of the thyroid laminae of the preparation and another representing the free margin of the vocal fold were demonstrated on the monitor oscilloscope (A-mode). This latter echo was unequivocally identified by the insertion of a thin metal needle under the marginal mucosa of the fold, which resulted in a change of the previously demonstrated echo. Further, the echo could be identified by a good correspondence between the distance displayed on the CRT and the actual distance from the transducer to the free edge of the investigated vocal fold.

Manipulation of the fold, resulting in adduction and abduction movements, were followed as corresponding movements of the previously identified echo on the monitor, whereas the remaining echoes did not move (Fig. 5). These slow movements of high amplitude were also demonstrated by TM-recording as an undulating curve (Fig. 6).

When the vocal folds were made to vibrate by application of the moist and heated air stream, the excursions of the echo on the

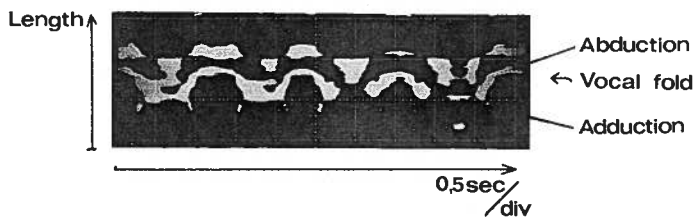

Fig. 6. Ultrasound registration of manipulations with a vocal fold. TM-display. The slow ab- and adductory movements of the vocal fold are represented by an undulating curve.

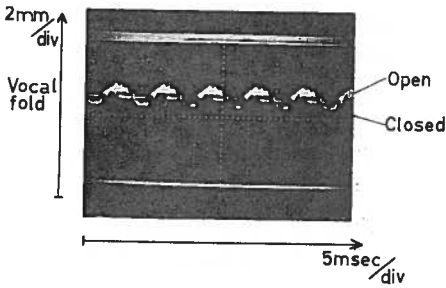

Fig. 7. Echoglottogram of vocal fold vibrating at 110 Hz. Note similarity of curves with the vibratory pattern well-known from high-speed films and photoglottography. The closed, opening- and closing phases can clearly be distinguished.

monitor were of course too fast for the naked eye to follow, and could only be perceived as a blurring of the vocal fold echo. By TM-display however, it was clearly possible to get distinct curves from the vibrating folds (Fig. 7). As seen from the figure, the repetition frequency of about 10 kHz was sufficient to give a continuous representation of vocal folds, vibrating at about 110 Hz.

DISCUSSION

Beach & Kelsey (1969) seem to be the only investigators who have correlated an ultrasonic

vocal cord recording with another sort of recording. They compared ultrasound Doppler signals from the region of the vocal folds with the actual vibratory phase as it appeared on the frames of a high-speed film. Velocities and displacements calculated from the Doppler signal did not always correlate well with the motions of the folds and the Doppler monitoring system proved unsatisfactory. It remains to be seen if this conclusion is valid also for the pulse echo method used in this paper. However, we do not find this very probable in view of the data presented in this report. The complex vibratory movements of the vocal folds with continuously changing surfaces act as sources of multiple echoes which merge into a single Doppler signal. Its integrated velocity curve is not correlated with the motion of any actual part of the vocal fold surface. These problems do not arise with the present method as multiple echoes are not integrated but displayed separated in time. This means that the distance to the echo-emitting structure can be accurately determined and that the most relevant echo can be distinguished.

Unlike earlier authors, we have not confined ourselves to obtaining curves from out-

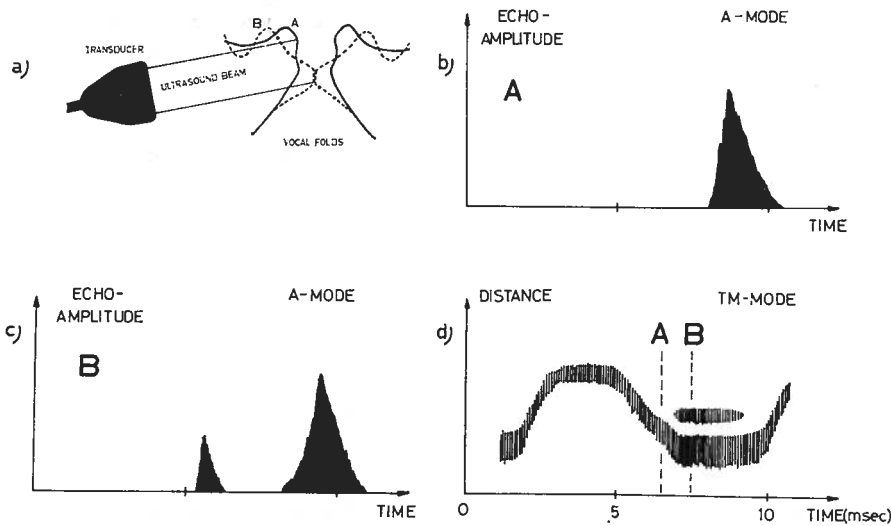

Fig. 8 a-d. Two diagrammatical frontal sections, A and B, showing the complex and changing vocal fold surface during vibration (a), sometimes causing mul-

multiple and irregular echoes displayed in A-mode (b and c) as well as in TM-mode (d).

side the neck. Instead, this paper is meant to be the first report on a systematic development of the method. In studies of laryngeal specimens we have been able to locate the echo-evoking structures directly in the larynx. Further, TM-displayed curves have been correlated to slow abductory and adductory movements as well as to vibrations of this same structure, i.e. the vocal fold.

In initial experiments we tried to apply the transducer directly to the thyroid cartilage of the preparation. These attempts failed as the echoes from the laryngeal structures were overshadowed by the start pulse because of the short distance. Therefore the larynx preparations were suspended in a vessel filled with water or saline.

In a special study, we analysed the ability of the echo to penetrate the laryngeal cartilages when these are more or less ossified. Earlier experience, e.g. from echo-encephalography (Jeppsson, 1961), has shown that cancellous bone can absorb ultrasound to a very high extent. It showed possible to solve this problem by the use of a suitable ultrasound frequency and by directing the ultrasound beam perpendicularly to the glottis and against the central parts of the thyroid cartilage.

In our opinion the greatest difficulty is bound up with the complex movement pattern of the vibrating vocal folds, earlier commented upon by Beach & Kelsey (1969) and described in detail by Schönhärl (1960) in his excellent monograph on laryngeal stroboscopy. The vibratory movements do not consist of single-surface amplitudes in only one, the horizontal, plane. Instead, waves of vibration on the vocal folds can be distinguished in all three dimensions of space, forming perpetually changing surfaces of very irregular configuration, as can be seen for instance from Schönhärl's Fig. 16. This of course will affect the resulting echoes, as is illustrated in Fig. 8.

Certain difficulties may arise in the clinical application of the method. The cranio-caudal movements of the entire larynx during change of phonatory pitch (e.g. Kitzing & Sonesson,

1967) and during deglutition may cause a momentary loss of the echo. Furthermore, the position of the transducer in relation to the vocal folds can be difficult to reproduce from one examination to another.

However, similar problems were encountered and solved in echocardiography when recording mitral valve motion. As shown by Edler (1961), examination with TM-display can be standardized in such a way that clinically important information is obtained in spite of these difficulties. The reason for this is that, unlike surrounding structures, the structure under investigation, i.e. the mitral valve, is in constant motion, which gives rise to characteristic and identifiable curves in TM-display. Conditions are analogous in the larynx.

ACKNOWLEDGMENTS

We are greatly indebted to Professor H. Hertz, Head of the Department of Electrical Measurements, Lund Institute of Technology, and Ass. Professor B. Sonesson, Department of Anatomy, University of Lund, for placing technical and anatomical facilities at our disposal.

ZUSAMMENFASSUNG

Ausser der elektronischen Laryngostroboskopie, die wie bekannt von der subjektiven Auffassung des Untersuchers abhängt, gibt es keine allgemein angewandte Methode zur kontinuierlichen Registrierung von Stimmbandschwingungen. Es ist deshalb schwer für den Laryngologen bzw. Phoniater, den Schwingungsvorgang an den Stimmlippen objektiv zu erfassen. Die vorliegende Arbeit befasst sich mit einer Methode für das Studium der Stimmbandschwingungen mit pulsierendem Ultraschall, der sog. Echoglottografie, die viele wesentliche Voraussetzungen aufweist, um die genannte Lücke in der Diagnostik der Stimmlippenfunktion zu schliessen.

Für die objektive, kontinuierliche Erfassung von Stimmlippenschwingungen wurde ein besonderes, hochempfindliches Ultraschallreflektoskop konstruiert, das die Verwendung von Schallköpfen mit verschiedener Ultraschallfrequenz erlaubt. Die Repetitionsfrequenz für die Ultraschallpulse betrug 10 kHz, womit bei genügender Eindringungstiefe des Ultraschalles ins Gewebe eine vollkommen ununterbrochene Aufzeichnung des schnellen Schwingungsverlaufes gewährleistet werden konnte. In vorbereitenden Versuchen erwies es sich als möglich, sogar verknöcherten Knorpel noch bei Frequenzen bis zu

4 MHz ultraschallmässig durchzudringen. Diese Frequenz gestattet eine gute Auflösung bei der Aufzeichnung von sowohl Entfernungs- als auch Grössenschwankungen eines Objekts.

Als Ausgangspunkt für die weitere Entwicklung einer echoglottografischen Methode sind mit Ultraschall gewonnene Aufzeichnungen von menschlichen Kehlkopfpreparaten studiert worden. Hierbei wurden Aufnahmen der freien Stimmbandkante erzielt, deren Ursprung unzweideutig feststand. Beim Anblasen und Schwingen der Stimmbänder ergaben sich Aufzeichnungen von charakteristischen Kurven, deren Form im Prinzip mit Glottogrammen von anderen, umständlicheren Methoden übereinstimmte.

REFERENCES

- Baker, D. 1970. Pulsed ultrasonic Doppler blood-flow sensing. *IEEE Trans on Sonics and Ultrasonics, SU 17*, 3, 170.
- Beach, J. L. & Kelsey, C. A. 1969. Ultrasonic doppler monitoring of vocal-fold velocity and displacement. *J Acoust Soc Amer* 46, 1045.
- Berg, J. van den et al. 1959. Results of experiments with human larynxes. *Pract Otorhinolaryng* (Basel) 21, 425.
- Edler, I. 1961. Ultrasound cardiography. *Acta Med Scand*, Suppl. 370.
- Fabre, Ph. 1957. Un procédé électrique percutané d'inscription de l'accolement glottique au cours de la phonation: glottographie de haute fréquence. Premiers résultats. *Bull Acad Nat Med* (Par.) 121, 66.
- Fant, G. 1961. A new anti-resonance circuit for inverse filtering. *STL-Quart Progr Stat Report* 4, 1.
- Farnsworth, D. W. 1940. High-speed motion pictures of the human vocal cords. *Bell Telephone Laboratories Record*, 18, 203.
- Frøkjær-Jensen, B. 1969. Construction and comparative tests of two different types of glottographs. Paper delivered at *Scandinavian Otolaryngological Congress*, Helsingör, 1969. From Institute of Phonetics, University of Copenhagen.
- Hertz, C. H. 1967. Ultrasonic engineering in heart diagnosis. *Amer J Cardiol* 19, 6.
- Hertz, C. H. & Edler, I. 1956. Die Registrierung von Herzwandbewegungen mit Hilfe des Ultraschall-Impulsverfahrens. *Acustica* 6, 361.
- Hertz, C. H., Lindström, K. & Sonesson, B. 1970. Ultrasonic recording of the vibrating vocal folds. *Acta Otolaryng* (Stockh.) 69, 223.
- Jeppsson, S. 1961. Echoencephalography. *Acta Chir Scand*, Suppl. 272.
- Kitamura, T. et al. 1968. Ultrasonoglottography. *Jap Soc Ultrasonics in Medicine*, 5, 30.
- 1968. Ultrasonoglottography. A preliminary report. *Ibid* 40.
- Kitzing, P. & Sonesson, B. 1967. Shape and shift of the laryngeal ventricle during phonation. *Acta Otolaryng* (Stockh.) 63, 479.
- Köster, J.-P. & Smith, S. 1970. Zur Interpretation elektrischer und photoelektrischer Glottogramme. *Folia Phoniatri* (Basel) 22, 92.
- Lanz, T. von & Wachsmuth, W. 1955. *Praktische Anatomie*. 1. Band, 2. Teil, Hals. 287. Springer-Verlag, Berlin, Göttingen, Heidelberg.
- Nessel, E. 1962. Über das Tonfrequenzspektrum der pathologisch veränderten Stimme. *Acta Otolaryng* (Stockh.), Suppl. 157.
- Schönhärl, E. 1960. *Die Stroboskopie in der praktischen Laryngologie*, Thieme Verlag, Stuttgart.
- Sonesson, B. 1960. On the anatomy and vibratory pattern of the human vocal folds. With special reference to a photo-electrical method for studying the vibratory movements. *Acta Otolaryng* (Stockh.), Suppl. 156.
- Teter, D. L. et al. 1969. High-speed photography of the larynx in a clinical setting. *Ann Otol* 78, 1227.
- Valley, G. E. & Wallman, H. 1948. Vacuum tube amplifiers. *Massachusetts Institute of Technology Radiation Laboratory Series*, Vol. 18, New York.
- Yanagihara, N. 1962. Acoustic studies on hoarseness. *Otorhinolaryng Clinic* (Kyoto) 55, 357.
- 1967. Significance of harmonic changes and noise components in hoarseness. *J Speech Res* 10, 531.

N.-G. Holmer, D.Sc.
Dept. of Electrical Measurements
Lund Institute of Technology
Box 725
S-220 07 Lund
Sweden

