



LUND UNIVERSITY

Appraisal of strategies to improve thermophilic hydrogen production exploiting *Caldicellulosiruptor* species

Byrne, Eoin

2019

Document Version:

Publisher's PDF, also known as Version of record

[Link to publication](#)

Citation for published version (APA):

Byrne, E. (2019). *Appraisal of strategies to improve thermophilic hydrogen production exploiting Caldicellulosiruptor species*. Department of Applied Microbiology, Lund University.

Total number of authors:

1

General rights

Unless other specific re-use rights are stated the following general rights apply:

Copyright and moral rights for the publications made accessible in the public portal are retained by the authors and/or other copyright owners and it is a condition of accessing publications that users recognise and abide by the legal requirements associated with these rights.

- Users may download and print one copy of any publication from the public portal for the purpose of private study or research.
- You may not further distribute the material or use it for any profit-making activity or commercial gain
- You may freely distribute the URL identifying the publication in the public portal

Read more about Creative commons licenses: <https://creativecommons.org/licenses/>

Take down policy

If you believe that this document breaches copyright please contact us providing details, and we will remove access to the work immediately and investigate your claim.

LUND UNIVERSITY

PO Box 117
221 00 Lund
+46 46-222 00 00



Appraisal of strategies to improve thermophilic hydrogen production exploiting *Caldicellulosiruptor* species

EOIN BYRNE | DIVISION OF APPLIED MICROBIOLOGY | LUND UNIVERSITY



Appraisal of strategies to improve thermophilic hydrogen production exploiting *Caldicellulosiruptor* species

Eoin Byrne



LUND
UNIVERSITY

DOCTORAL DISSERTATION

by due permission of the Faculty of Engineering, Lund University, Sweden.
To be defended in Lecture Hall B, Kemicentrum, Naturvetarvägen 14 on

26th April 2019 at 10:00

Faculty opponent

Professor Jóhann Örlygsson, Faculty of Natural Resource Sciences,
University of Akureyri, Iceland

Organization LUND UNIVERSITY	Document name Doctoral Dissertation	
	Date of issue 2019-04-26	
Author: Eoin Byrne	Sponsoring organization Energimyndigheten	
Title and subtitle Appraisal of strategies to improve thermophilic hydrogen production exploiting <i>Caldicellulosiruptor</i> species		
<p>Abstract</p> <p>The transition from a fossil to a bio-based economy is of vital importance to stem the effects of ongoing climate change. This bio-based economy will necessitate the production of both biofuels and chemical compounds from biological sources. Hydrogen is a promising candidate as a renewable energy carrier due to its high energy density, carbon neutrality when combusted and its potential use as a reducing agent to produce biochemicals. <i>Caldicellulosiruptor</i> is a genus of extreme thermophilic bacteria capable of producing hydrogen close to the theoretical maximum of 4 mol H₂/mol hexose from an array of different mono-, oligo- and polymeric sugars permitting the utilisation of a diverse range of lignocellulose substrates. Although promising, the advancement of <i>Caldicellulosiruptor</i> towards becoming a model organism for hydrogen production relies on overcoming the intrinsic hurdles that exist in this genus, such as osmosensitivity, low Q_{H₂} and the high financial cost of nutrient addition.</p> <p>Throughout this work, techniques for improving the <i>Caldicellulosiruptor</i> process were studied in detail. Adaptive laboratory evolution was employed as a technique to increase osmotolerance by incremental adaption to elevated glucose concentrations, thereby facilitating development of osmotolerant strains belonging to five species of <i>Caldicellulosiruptor</i>. Notably, the degree of adaption to higher osmolarity varies depending on the species. The osmotolerant strain <i>C. owensensis</i> CO80 was demonstrated to grow at glucose concentrations up to 80 g/l; nevertheless, the highest Q_{H₂} values for this strain were observed with lower osmolarity media. <i>C. owensensis</i> CO80 was further implemented with the osmotolerant strain, <i>C. saccharolyticus</i> G5, as a co-culture to produce hydrogen from concentrated hydrolysates, in which the wild-type strains are unable to be cultivated.</p> <p>Several strategies to optimise of nutrient addition to the fermentation process were studied, including designed co-culture with <i>Coprothermobacter proteolyticus</i>, vitamin removal and the design of a new trace element solution. The implementation of a novel trace element solution (EB-1) permitted a phosphorus reduction of 90% compared to previous cultivations. However, further optimisation of the trace elements and vitamin addition are required to increase Q_{H₂}.</p> <p>Process integration was undertaken by further fermentation of the effluent of <i>Caldicellulosiruptor</i> cultivated on lignocellulose hydrolysates to yield methane and polyhydroxybutyrate by a methanogenic consortium and <i>Ralstonia eutropha</i>, respectively. These studies illustrate that acetate produced by <i>Caldicellulosiruptor</i> can be further fermented into industrially relevant compounds.</p> <p>In addition, several key physiological attributes of <i>C. saccharolyticus</i> fermentation were also studied. Although, <i>C. saccharolyticus</i> co-ferments sugars, a diauxic-like production of hydrogen occurs when <i>C. saccharolyticus</i> is batch cultivated with a mixture of glucose, xylose and arabinose. This effect is amplified when wheat straw hydrolysate is used as a substrate. It was also observed that xylose is fully consumed after 25 hours while full glucose consumption requires over 80 hours. In addition, continuous cultivation of osmotolerant strains on the studied hydrolysates displayed full xylose consumption, while a significant portion of glucose remained in the effluent. Co-culturing of <i>C. saccharolyticus</i> with the proteolytic hydrogen-producing <i>Coprothermobacter proteolyticus</i> marginally increased Q_{H₂} compared to the mono-culture. However, a significant reduction in Q_{H₂} was observed when <i>C. saccharolyticus</i> was cultivated at 60°C, due to the lower growth temperature causing a significant metabolic shift from acetate to lactate.</p> <p>The compiled findings of this thesis opens up new avenues of research and will act as a stepping stone for further strain development, media optimisation and process integration exploiting the <i>Caldicellulosiruptor</i> genus.</p>		
Key words <i>Caldicellulosiruptor</i> , hydrogen, biorefinery, osmolarity, osmotolerance, Adaptive laboratory evolution, co-culture, volumetric productivity, methane, polyhydroxybutyrate, <i>Coprothermobacter proteolyticus</i>		
Classification system and/or index terms (if any)		
Supplementary bibliographical information		Language
ISSN and key title		ISBN 978-91-7422-642-3
Recipient's notes	Number of pages 184	Price
	Security classification	

I, the undersigned, being the copyright owner of the abstract of the above-mentioned dissertation, hereby grant to all reference sources permission to publish and disseminate the abstract of the above-mentioned dissertation.

Signature Eoin Byrne Date 2019-03-19

Appraisal of strategies to improve
thermophilic hydrogen production
exploiting *Caldicellulosiruptor* species

Eoin Byrne



LUND
UNIVERSITY

Cover photo by Jim Peaco, Yellowstone National Park

Back cover drawing by Eoin Byrne

Copyright Eoin Byrne

Paper I © by the Authors (Manuscript unpublished)

Paper II © Biotechnology for Biofuels

Paper III © Bioresource Technology

Paper IV © Biotechnology for Biofuels

Paper V © by the Authors (Manuscript unpublished)

Division of Applied Microbiology

Department of Chemistry

Faculty of Engineering

Lund University

P.O. Box 124

SE-221 00 Lund

Sweden

ISBN 978-91-7422-642-3 (Print)

ISBN 978-91-7422-650-8 (Electronic)

Printed in Sweden by Media-Tryck, Lund University

Lund 2019



Media-Tryck is an environmentally certified and ISO 14001:2015 certified provider of printed material. Read more about our environmental work at www.mediatryck.lu.se

MADE IN SWEDEN 

Table of contents

Popular science summary.....	vii
Abstract.....	ix
List of publications.....	xi
My contributions to the papers.....	xii
Abbreviations.....	xiii
List of figures.....	xiv
List of tables.....	xiv
1. Biorefinery Concept.....	1
1.1 Biofuels.....	1
1.1.1 First generation biofuels.....	2
1.1.2 Second generation biofuels.....	2
1.1.3 Lignocellulose.....	3
1.1.4 Third and fourth generation biofuels.....	4
1.2 Biorefinery.....	4
1.3 Lignocellulose pretreatment.....	5
1.3.1 Physical pretreatment.....	5
1.3.2 Chemical pretreatment.....	5
1.3.3 Physiochemical pretreatment.....	6
1.3.4 Biological pretreatment.....	6
1.3.5 Enzymatic hydrolysis.....	7
1.4 Products in biorefinery.....	7
1.4.1 Thermochemical products.....	7
1.4.2 Fermentation products.....	9
1.5 Hydrogen and biorefinery.....	9
2. Biohydrogen.....	11
2.1 Enzymes.....	11
2.2 Mechanisms of biohydrogen production.....	12
2.2.1 Direct biophotolysis.....	12
2.2.2 Indirect biophotolysis.....	14
2.2.3 Photofermentation.....	14

2.2.4 Dark fermentation.....	14
2.2.5 Dark fermentation cultures	16
2.2.6 Thermophilic fermentation	17
3. <i>Caldicellulosiruptor</i>	19
3.1 Substrate utilisation.....	19
3.2 Hydrogen production	22
3.2.1 Hydrogen production from lignocellulose.....	22
3.3 Limitations of <i>Caldicellulosiruptor</i>	26
3.3.1 Hydrogen partial pressure.....	26
3.3.2 Osmolarity	26
3.3.3 Volumetric hydrogen productivity	27
3.3.4 Substrate costs	28
4. Improvement of hydrogen production by <i>Caldicellulosiruptor</i>	29
4.1 Strain improvement.....	29
4.1.1 Adaptive laboratory evolution	29
4.2 Process improvement	32
4.2.1 Designed co-cultures	32
4.2.2 Biofilm.....	34
4.2.3 Substrate optimisation	36
4.2.4 Process coupling.....	37
5. Future development of the <i>Caldicellulosiruptor</i> process	39
5.1 Process design	39
5.1.1 Consolidated bioprocess.....	39
5.1.2 Fermentation processes	41
5.1.3 Additional products	44
5.1.4 Media optimisation.....	45
5.2 Strain development.....	45
5.2.1 Adaptive laboratory evolution	45
5.2.2 Genetic methods	46
5.3 Co-cultivation.....	47
6. Conclusions	49
Acknowledgements	51
References	53

Popular science summary

Climate change is causing an irrevocable alteration to the global environment, weather patterns and ecosystems. In part, our dependence on fossil fuels as our primary source of energy is responsible for global climate change. To mitigate the effects of future climate change, fossil fuels must be substituted with fuels derived from renewable sources. Biofuels can be produced renewably from energy crops such as corn, sugarcane, rapeseed or other plant material. However, the production of biofuel from energy crops has been criticised due to the possible competition with food production. This can be avoided by using lignocellulosic biomass as a source of raw material. Lignocellulose refers to plant material that is largely inedible and can be derived from purposely cultivated sources, such as forestry and grasses or from process by-products such as forestry and agricultural residues.

In addition to energy, compounds derived from fossil fuels are required for the production of a vast array of industrial products, e.g. food additives, pharmaceutical products, textiles, paints, and inks. Future development must focus on producing both sustainable fuel and industrially relevant chemicals using renewable sources, such as biomass. This can be accomplished through a process known as "biorefinery" whereby a selection of fuels and chemical products are produced from lignocellulose via a mixture of fermentation and chemical processes.

Hydrogen is of great interest within the biorefinery concept due to its potential as an energy carrier and its use in chemical reaction to yield additional products. Hydrogen has the additional advantage of being one of the cleanest fuels available as when combusted or used in a fuel cell, water is the sole by-product. Hydrogen can be obtained by using bacteria that grow on lignocellulose.

Caldicellulosiruptor is a group of promising hydrogen producing bacteria that grow on many different types of sugars and lignocellulose. In addition to hydrogen, *Caldicellulosiruptor* produces acetate as a by-product. This acetate can be further fermented using different microorganisms to yield additional products. In this thesis, the production of methane and polyhydroxybutyrate were studied from the effluent of the fermentations with *Caldicellulosiruptor* species. Methane is a combustible gas and is the main constituent of natural gas, whereas polyhydroxybutyrate is a bioplastic generated by bacteria that can be moulded and is biodegradable.

However, *Caldicellulosiruptor* is unable to produce a sufficiently large quantity of hydrogen in respect to the reactor volume and cannot grow in concentrated solutions, thereby limiting its ability to grow on treated lignocellulose. In this thesis several approaches were taken to improve the capability of *Caldicellulosiruptor* to grow in concentrated solutions and produce high quantities of hydrogen. Adaptive laboratory evolution is a process that relies on the principles

of evolution to develop bacteria with improved properties. Adaptive laboratory evolution involves applying a stress to the bacteria; over time, some of these bacteria are capable of adapting to this stress condition, reproducing and out competing the bacteria that have not adapted. This strategy was used to adapt *Caldicellulosiruptor* to overcome its innate sensitivity to high sugar concentrations by adaption to sequentially elevated amounts of sugar. A further approach taken to increase the hydrogen production involved growing different types of bacteria together. When grown together certain bacteria can enhance the metabolisms of others by several mechanisms, including producing nutrients that other organisms can use. In this thesis, two types of adapted *Caldicellulosiruptor*, *Caldicellulosiruptor saccharolyticus* and *Caldicellulosiruptor owensensis*, were grown together as the non-adapted strains have been previously shown to increase hydrogen productivity when cultivated in a mixed culture. In addition, *Caldicellulosiruptor saccharolyticus* and *Coprothermobacter proteolyticus* were cultivated together as *Coprothermobacter proteolyticus* can provide a nitrogen source to *Caldicellulosiruptor saccharolyticus* by the degradation of protein. Additionally, studies also included the creation of new formulations of nutrients and removal of the vitamin solution to minimise process costs while attempting to retain optimal hydrogen production.

This thesis has investigated the enhancement of hydrogen production by *Caldicellulosiruptor*, coupling of hydrogen production to the generation of additional products and reduction or elimination of the addition of high cost compounds such as vitamins and phosphorus, thereby moving the *Caldicellulosiruptor* hydrogen platform towards integration into a biorefinery process.

Abstract

The transition from a fossil to a bio-based economy is of vital importance to stem the effects of ongoing climate change. This bio-based economy will necessitate the production of both biofuels and chemical compounds from biological sources. Hydrogen is a promising candidate as a renewable energy carrier due to its high energy density, carbon neutrality when combusted and its potential use as a reducing agent to produce biochemicals. *Caldicellulosiruptor* is a genus of extreme thermophilic bacteria capable of producing hydrogen close to the theoretical maximum of 4 mol H₂/mol hexose from an array of different mono-, oligo- and polymeric sugars permitting the utilisation of a diverse range of lignocellulose substrates. Although promising, the advancement of *Caldicellulosiruptor* towards becoming a model organism for hydrogen production relies on overcoming the intrinsic hurdles that exist in this genus, such as osmosensitivity, low Q_{H2} and the high financial cost of nutrient addition.

Throughout this work, techniques for improving the *Caldicellulosiruptor* process were studied in detail. Adaptive laboratory evolution was employed as a technique to increase osmotolerance by incremental adaption to elevated glucose concentrations, thereby facilitating development of osmotolerant strains belonging to five species of *Caldicellulosiruptor*. Notably, the degree of adaption to higher osmolarity varies depending on the species. The osmotolerant strain *C. owensensis* CO80 was demonstrated to grow at glucose concentrations up to 80 g/l; nevertheless, the highest Q_{H2} values for this strain were observed with lower osmolarity media. *C. owensensis* CO80 was further implemented with the osmotolerant strain, *C. saccharolyticus* G5, as a co-culture to produce hydrogen from concentrated hydrolysates, in which the wild-type strains are unable to be cultivated.

Several strategies to optimise of nutrient addition to the fermentation process were studied, including designed co-culture with *Coprothermobacter proteolyticus*, vitamin removal and the design of a new trace element solution. The implementation of a novel trace element solution (EB-1) permitted a phosphorus reduction of 90% compared to previous cultivations. However, further optimisation of the trace elements and vitamin addition are required to increase Q_{H2}.

Process integration was undertaken by further fermentation of the effluent of *Caldicellulosiruptor* cultivated on lignocellulose hydrolysates to yield methane and polyhydroxybutyrate by a methanogenic consortium and *Ralstonia eutropha*, respectively. These studies illustrate that acetate produced by *Caldicellulosiruptor* can be further fermented into industrially relevant compounds.

In addition, several key physiological attributes of *C. saccharolyticus* fermentation were also studied. Although, *C. saccharolyticus* co-ferments sugars,

a diauxic-like production of hydrogen occurs when *C. saccharolyticus* is batch cultivated with a mixture of glucose, xylose and arabinose. This effect is amplified when wheat straw hydrolysate is used as a substrate. It was also observed that xylose is fully consumed after 25 hours while full glucose consumption requires over 80 hours. In addition, continuous cultivation of osmotolerant strains on the studied hydrolysates displayed full xylose consumption, while a significant portion of glucose remained in the effluent. Co-culturing of *C. saccharolyticus* with the proteolytic hydrogen-producing *Coprothermobacter proteolyticus* marginally increased Q_{H_2} compared to the mono-culture. However, a significant reduction in Q_{H_2} was observed when *C. saccharolyticus* was cultivated at 60°C, due to the lower growth temperature causing a significant metabolic shift from acetate to lactate.

The compiled findings of this thesis opens up new avenues of research and will act as a stepping stone for further strain development, media optimisation and process integration exploiting the *Caldicellulosiruptor* genus.

List of publications

This thesis is based on the following publications and manuscripts, which will be referred to by Roman numerals:

- I. Characterization and development of osmotolerant *Caldicellulosiruptor* strains targeting enhanced hydrogen production from lignocellulosic hydrolysates**
Byrne, E., Björkmalm J, Bostick J.P., Willquist, K., van Niel, EWJ.
- II. Reduced use of phosphorus and water in sequential dark fermentation and anaerobic digestion of wheat straw and the application of ensiled steam-pretreated lucerne as a macronutrient provider in anaerobic digestion**
Byrne, E., Kovacs, K., van Niel, E.W.J., Willquist, K., Svensson, S.-E., Kreuger, E. 2018 *Biotechnology for Biofuels*, 11(1), 281.
- III. Hydrogen and polyhydroxybutyrate production from wheat straw hydrolysate using *Caldicellulosiruptor* species and *Ralstonia eutropha* in a coupled process**
Soto, L.R., Byrne, E., van Niel, E.W.J., Sayed, M., Villanueva, C.C., Hatti-Kaul, R. 2019. *Bioresource Technology*, 272, 259-266.
- IV. A non-linear model of hydrogen production by *Caldicellulosiruptor saccharolyticus* for diauxic-like consumption of lignocellulosic sugar mixtures.**
Björkmalm, J., Byrne, E., van Niel, E.W.J., Willquist, K. 2018, *Biotechnology for Biofuels*, 11(1), 175.
- V. Assessment of nutrient cost reduction in *Caldicellulosiruptor saccharolyticus* cultivation by designed co-culture and vitamin omission**
Byrne, E., Helgadóttir, H., Willquist, K., van Niel, E.W.J.

I have also contributed to the following book chapter:

- A. Biological hydrogen production from lignocellulosic biomass**
Pawar, S., Byrne, E., van Niel, E.W.J.

My contributions to the papers

- I. I planned, designed and performed all adaptive evolution experiments, continuous fermentations and metabolite analysis fermentations. I planned and designed all batch cultivations. I trained the student, James Bostick, who conducted batch cultivations and metabolite analysis under my supervision. I drafted this manuscript along with Johanna Björkmalm.
- II. I planned, designed and performed all dark fermentation cultivations and metabolite analysis of the dark fermentation process. I designed the trace element solution for dark fermentation. I drafted this manuscript with Dr Emma Kreuger and Dr Krisztina Kovacs.
- III. I planned, designed and performed continuous cultivations and metabolite analysis of the dark fermentation process. I drafted this manuscript with Luis Romero Soto
- IV. I planned, designed and performed all batch cultivations and metabolite analysis. I drafted this manuscript along with Johanna Björkmalm.
- V. I generated the idea behind this study and subsequently planned and designed all cultivations. I trained the students, Anne-Laure Moisson and Helga Helgadóttir, who conducted batch and continuous cultivations, metabolite analysis, flow cytometry and bioinformatics under my supervision. I drafted this entire manuscript.

Abbreviations

ABC	ATP binding cassette
ALE	Adaptive laboratory evolution
ATP	Adenosine triphosphate
CBP	Consolidated bioprocess
COD	Chemical oxygen demand
CSTR	Continuous stirred-tank reactor
Fd _{ox}	Oxidised ferredoxin
Fd _{red}	Reduced ferredoxin
GAP	Glyceraldehyde 3-phosphate
H ₂	Hydrogen
HMF	Hydroxymethylfurfural
NADH	Nicotinamide adenine dinucleotide
PHB	Polyhydroxybutyrate
Q _{H2}	Volumetric hydrogen productivity
SHF	Separate hydrolysis and fermentation
Y _{H2}	Hydrogen yield

List of figures

Figure 1 Potential products and processes in a biorefinery.....	8
Figure 2 Metabolic pathways for hydrogen production via dark fermentation via formation of formate (A) and ferredoxin (B).....	15
Figure 3 Schematic illustration of the Embden Meyerhof pathway in <i>C. saccharolyticus</i>	25
Figure 4 Illustration of subcultivations involved in the stepwise adaption of <i>Caldicellulosiruptor</i> species to higher osmolarity media	31
Figure 5 Development of osmotolerant strains of <i>Caldicellulosiruptor</i>	31
Figure 6 Nutrient recycling during a <i>Caldicellulosiruptor</i> and <i>Coprothomobacter</i> co-cultivation	34
Figure 7 Scanning electron micrograph of a co-culture of <i>C. saccharolyticus</i> and <i>C. owensensis</i> wild types	35
Figure 8 Biofilm formation during co-cultivation of <i>C. saccharolyticus</i> G5 and <i>C. owensensis</i> CO80 cultivated on wheat straw hydrolysate.....	35
Figure 9 Illustration of a separate hydrolysis and fermentation (a) and consolidated bioprocessing (b) involving <i>Caldicellulosiruptor</i>	41

List of tables

Table 1 Fermentation products generated from different sources of lignocellulose and their potential industrial applications	10
Table 2 Comparison of biohydrogen production via different mechanisms.....	13
Table 3 Comparison of the species of the <i>Caldicellulosiruptor</i> genus.....	20
Table 4 Cultivation of <i>Caldicellulosiruptor</i> on various lignocellulose substrates.....	23
Table 5 Production of hydrogen by <i>Caldicellulosiruptor</i> in various reactor configurations	43

1. Biorefinery Concept

Our continuing reliance on fossil based fuels as the primary global source of energy is environmentally unsustainable. The ongoing release of greenhouse gases from the combustion of fuels such as oil, coal and natural gas is resulting in global climate change (United Nations 2018). Global warming has become a high priority with international agreements such as the recent Paris agreement and the Katowice climate package committing to limit global warming to 1.5°C of pre-industrial levels. The EU energy strategies for 2030 and 2050 state that by 2030 renewable energy should be increased to 32% of total energy production and by 2050, the total greenhouse emissions should be decreased by 60% compared to 1990 levels (European Commission 2012, European Commission 2014). To reduce greenhouse gas production and limit global warming into the future, fossil fuels must be superseded with renewable alternative fuels, such as biofuels.

1.1 Biofuels

A biofuel is a solid, liquid or gaseous fuel that can be produced from renewable sources such as plant biomass (Demirbas 2009). Biofuels have a long history and have been used, particularly in the case of solid fuel, since before recorded history as a source of heating, cooking and lighting (Guo et al. 2015). Although, oil is the now predominant fuel in automobiles, the early development of this industry focused on biofuels. Peanut oil was used by Rudolf Diesel in an engine during a demonstration in 1900 while the Ford Model-T was designed to use both petroleum and ethanol (Altn et al. 2001). Currently, transport is responsible for 34% of global energy consumption, while only 4% of transport fuel is sourced from biologically derived biofuels (International Energy Agency 2017a, International Energy Agency 2017b). Biofuels can be derived from a variety of different materials such as dedicated crops, lignocellulose, wastes and algae. Biofuels can be classified into four generations based on the source of raw material.

1.1.1 First generation biofuels

First generation biofuels refer to biofuels that are produced from crop-based plants such as sugar cane, corn and rapeseed (Aro 2016). First generation sources are generally high in fermentable sugars permitting direct conversion to biofuel through fermentation processes (Cherubini 2010). Although, first generation biofuels provide an overall reduction of greenhouse emissions, they could potentially compete with food production in terms of land usage, thereby leading to higher global food prices (Sims et al. 2008). However, the effect that cultivation of these energy crops have on food prices is subject to debate. In principle, the development of first generation biofuels will increase food prices by the displacement of food production and the development of competition between food and biofuel supply (Searchinger et al. 2008, Sims et al. 2008). However, this link between biofuels and food prices has also been described as an over-simplistic argument with other factors such as food subsidisation, trade tariffs and the potential co-usage of crops for both food and biofuel production, also having a significant influence (Ajanovic 2011, Tomei & Helliwell 2016). The expansion of biofuel production could result in direct or indirect change in land usage, i.e. the conversion of previously forested areas to dedicated biofuel cultivation (Elshout et al. 2015, Lapola et al. 2010). Although, the production of biofuels reduces greenhouse gas emissions, the initial loss of the natural ecosystem's carbon stocks results in a large release of greenhouse gases. As a result, the time required to compensate for this initial release of greenhouse gases by carbon offset through the use of biofuels derived from these lands can be between one year to over a century depending on the previous land usage (Elshout et al. 2015). Current EU legislation limits the amount of biofuel that can be produced from land dedicated to biofuel production to 7% of total energy production (European Parliament and Council 2015).

1.1.2 Second generation biofuels

“The fuel of the future is going to come from fruit like that sumac out by the road, or from apples, weeds, sawdust - almost anything. There is fuel in every bit of vegetable matter that can be fermented” – Henry Ford (Associated Press 1925)

Second generation biofuels (advanced biofuels) are fuels generated from lignocelluloses (plant biomass) not suitable for food use. Lignocellulose can be derived from agricultural by-products (wheat straw, sugar cane bagasse, etc.), municipal waste or dedicated biomass (switchgrass, managed forest, etc.) (Sims et al. 2010). Lignocellulose is an ideal feedstock for biofuel production due to its renewable production and the sizable quantity available. It is estimated that annual production of lignocellulose globally is 10-50 Gt and has been described as “the

most abundant and renewable organic component in the biosphere.” (Claassen et al. 1999). Second generation biofuels were industrially produced as early as the beginning of the 20th century; however, the majority of biofuels currently in use are derived from first generation sources with only limited quantities sourced from second generation lignocellulose (International Energy Agency 2017b, Sherrard & Kressman 1945). From 2021, 0.5% of transport fuel in the EU must originate from second generation biomass, increasing to 3.6% by 2030 (European Parliament 2018).

Lignocellulose can be produced from “dedicated biomass”, whereby lignocellulose is cultivated with the sole purpose of producing biofuel, i.e. through managed high turnover forests or perennial grasses such as switchgrass (Naik et al. 2010). As lignocellulose arising from these sources require land for ad hoc biofuel production, they can potentially displace agricultural production similar to first generation sources. This can be somewhat mitigated by the use of marginal or degraded land (Havlik et al. 2011). Similar to first generation biofuels, the quantity of land that can be dedicated to biofuel production from these sources is limited by current EU legislation (European Parliament and Council 2015).

Lignocellulose can also be obtained from the residues of forestry and cereal production, e.g. wheat straw and corn stover. An estimated 40 Mt of lignocellulose residue is generated annually from agriculture, of which a majority goes unutilised (Sanderson 2011). These agricultural residues are ideal biofuel sources as this material is inedible by humans and does not necessitate additional land usage, thereby avoiding direct competition with food production (Mabee et al. 2011, Rogoff & Rawlins 1987).

1.1.3 Lignocellulose

Approximately 90% of the dry weight of lignocellulose comprises of three biopolymers: cellulose, hemicellulose and lignin (Hadar 2013). In contrast to energy crops, lignocellulose generally contains little fermentable monosaccharide sugars. Both cellulose and hemicellulose can be hydrolysed into simple sugars facilitating further fermentation (Hamelinck et al. 2005).

Cellulose is a polysaccharide that constitutes 40-60% of the dry weight of lignocellulose and is typically the most prevalent polysaccharide in lignocellulose biomass (Hamelinck et al. 2005). Cellulose is a linear molecule consisting of glucose units linked by β -1,4 glycosidic bonds (Pérez et al. 2002). Hemicellulose can comprise 20-40% of lignocellulose biomass (Hamelinck et al. 2005). Hemicellulose is a branched polysaccharide with a lower molecular weight compared to that of cellulose (McKendry 2002). Unlike cellulose, hemicellulose can comprise of numerous sugars including glucose, xylose, arabinose, mannose and various uronic units, i.e. 4-O-methyl-glucuronic, D-galacturonic and D-

glucuronic acids (Jermyn 1955, Pérez et al. 2002). The monosaccharide composition of hemicelluloses vary considerably between different plant materials (Schädel et al. 2010). Lignin is a large complex polyphenolic polymer which constitutes up to 10-25% of lignocellulose (Hamelinck et al. 2005).

1.1.4 Third and fourth generation biofuels

Third generation biofuels utilise microalgae for the production of bioethanol and biodiesel. However, in contrast to first and second generation biofuels, third generation biofuels do not involve the use of plant biomass or require the presence of fermentable sugars but rather rely on photosynthesis with CO₂ as a carbon source (Maity et al. 2014). Fourth generation biofuels refer to the improvement of third generation processes by molecular engineering of microalgae to increase efficiency of CO₂ uptake, and the productivity of fermentation and lipid production (Dutta et al. 2014).

1.2 Biorefinery

The current refinement processes for crude oil yields a plethora of industrially valuable products (Vennestrøm et al. 2011). Approximately, 5-10% of crude oil is used for the production of petrochemicals, including ethylene, propylene, benzene, butanediol, methanol and a variety of other olefins (Cherubini 2010, Vennestrøm et al. 2011). These petrochemicals are used in a vast array of industries, e.g. food additives, cosmetics, plastics, pesticides, textiles, pharmaceuticals and intermediates in chemical synthesis (Rinaldi & Schüth 2009). The replacement of fossil fuels with biofuels will also require the development of platforms for the production of biologically derived chemical products to supplant those from petrochemicals.

The biorefinery concept is analogous to current oil refinery, whereby fuel and chemicals or chemical precursors are generated during the refinement process. However, in the case of biorefinery, the input carbon source originates from plant biomass, i.e. lignocellulose (Octave & Thomas 2009). A biorefinery would yield an array of compounds, including intermediate and final chemical products, suitable for a wide range of industrial processes and energy production (de Jong & Jungmeier 2015). Utilising biorefinery rather than linear biofuel production is economically beneficial as it allows the additional production of high value products (de Jong & Jungmeier 2015). Due to the complexity and variation of lignocellulose, both in polymer quantities and the composition of hemicelluloses, many different products can be generated (Cherubini 2010). However, as such

variation exists biorefineries must employ more processing methods than current oil-based refinery (Carvalho et al. 2008).

1.3 Lignocellulose pretreatment

The accessibility of cellulose and hemicellulose is hampered by lignocellulose recalcitrance. Lignocellulose recalcitrance refers to the plant materials natural robustness against degradation by microorganisms, enzymes and higher animals due to presence of waxes on the epidermal tissues, the quantity of lignin and structural heterogeneity of polymers of the cell wall (Himmel et al. 2007). This recalcitrance poses a significant hurdle for the implementation of lignocellulose in a biorefinery system. To overcome this hindrance, it is necessary that the biomass is first pretreated to permit access to these polysaccharides (Kumar et al. 2009b). Biomass pretreatment relies on the degradation of lignin and the alteration of the crystalline structure of cellulose to enable access of enzymes capable of hydrolysing cellulose and hemicellulose into smaller monomeric sugars, thereby allowing fermentation processes (Mosier et al. 2005). Lignocellulose can be pretreated via a number of different mechanisms including: physical, chemical, physicochemical, biological and enzymatic hydrolysis (Cherubini 2010, Kumar & Sharma 2017).

1.3.1 Physical pretreatment

Physical pretreatment relies on techniques that do not change the composition of lignocellulose but rather reduces its particle size by the application of mechanical stress (Cherubini 2010, da Costa Sousa et al. 2009). Milling is a commonly employed method that involves the cutting of the lignocellulose material creating a greater surface area and a decrease in the degree of polymerisation, facilitating greater monosaccharide yields through hydrolysis (Taherzadeh & Karimi 2008). Milling does not lead to the production of inhibitory compounds such as hydroxymethylfurfural (HMF) and furfural as no heating or pH change occurs (Hendriks & Zeeman 2009).

1.3.2 Chemical pretreatment

Chemical pretreatment involves the addition of chemical compounds to degrade lignocellulose into smaller monomers. Compounds employed to degrade cellulose, hemicellulose and lignin include acids, bases, salts and oxidising agents (Behera et al. 2014). The application of basic compounds, e.g. NaOH, results in a decrease

in cellulose crystallinity and degree of polymerisation, whereas acid pretreatment grants greater access to cellulose by degradation of hemicellulose into monomeric sugars (Agbor et al. 2011). Acid pretreatment involves the addition of dilute acids to degrade cellulose and hemicellulose into fermentable monomer sugars at high temperatures. Temperature is a critical parameter in chemical pretreatment as elevated temperatures will result in the decomposition of pentose sugars. On the other hand, higher temperatures are required to promote cellulose degradation (Lenihan et al. 2010). Furthermore, the combination of acid hydrolysis and high temperature promotes the formation of inhibitory compounds such as HMF and furfural from the degradation of monosaccharides (Wyman 1994).

1.3.3 Physiochemical pretreatment

Physiochemical pretreatments rely on a combination of physical and chemical processes to degrade lignocellulose, including steam explosion, liquid hot water and organosolv, of which steam explosion is one of the most widely implemented pretreatment methods for lignocellulose (Behera et al. 2014, da Costa Sousa et al. 2009). Steam explosion entails the heating of a mixture of lignocellulose and water under high pressure for a period of time, after which the pressure is allowed to drop rapidly creating a steam explosion. During the heating phase hemicellulose is hydrolysed, releasing acetate which in turn results in further hydrolysis (Mosier et al. 2005) Steam explosion pretreatment can be further catalysed by the addition of acid (Morjanoff & Gray 1987).

1.3.4 Biological pretreatment

Many microorganisms possess the capacity to directly degrade lignocellulose through the production of various enzymes, e.g. numerous species of fungi can directly depolymerise cellulose by producing extracellular hydrolases or by degrade lignin using enzymes such as laccases (Sánchez 2009, Sindhu et al. 2016). Biological pretreatment can be directly integrated in a combined pretreatment and fermentation process known as a consolidated bioprocess, whereby, cellulose and hemicellulose are degraded with enzymes, e.g. cellulase and xylanase, thereby producing monomeric sugars that can be metabolised by the fermentation organism(s) to produce a desired product (Lynd et al. 1996). An example of consolidated bioprocessing was the fermentation of non-pretreated switchgrass by *Caldicellulosiruptor saccharolyticus* to produce biohydrogen (Talluri et al. 2013). The disadvantage of both biological pretreatment and consolidated bioprocessing is that an increased reaction time is required (Kumar et al. 2009b).

1.3.5 Enzymatic hydrolysis

In enzymatic hydrolysis a mixture of enzymes is added to lignocellulose to degrade the cellulose and hemicellulose fractions into smaller fermentable sugar molecules. A cocktail of cellulases are employed to degrade cellulose to the disaccharide cellubiose, e.g. endoglucanases and exoglucanases. Additionally, β -glucosidase can be added to further degrade cellubiose to glucose. Enzymes such as xylanase, acetyl-esterase and glucomannanase can also be implemented to degrade hemicellulose (Sun & Cheng 2002). Due to the recalcitrance of lignocellulose, generally enzymatic hydrolysis must be implemented after an initial pretreatment step (Chandra et al. 2007).

1.4 Products in biorefinery

The products generated by a biorefinery process can be divided into energy, material, and, energy and material products. Energy products refer to compounds, such as biodiesel, where energy can be derived to produce heat, electricity or a fuel source for transportation or other industrial processes. Material products are compounds derived via the biorefinery process that are not used for energy production but can be utilised as final or intermediate products, e.g. biomaterials, bioplastics, organic acid, chemicals and chemical intermediates. Biohydrogen can be classified as both an energy and material product due to its ability to function as an energy carrier or a reducing agent in chemical synthesis, within and beyond the biorefinery process (Cherubini 2010). In a biorefinery the desired fuels and chemicals can be generated from the lignocellulose feedstock through a variety of methods including chemical, thermochemical and biological transformation (Fig. 1).

1.4.1 Thermochemical products

Thermochemical processes using lignocellulose involve the direct conversion of biomass into products using high temperatures and generally fall into four categories; combustion, liquefaction, gasification and pyrolysis (Demirbas 2009, Kumar et al. 2009a). Liquefaction involves heating the biomass between 250 – 400 °C under high pressure (50-200 Bar) to yield bio-oil, gas residue and a solid residue (Huang & Yuan 2015). Gasification is a process in which the solid biomass is converted into a gaseous fuel (syngas) via heating the biomass to 800–1300 °C and controlling oxygen content to prevent complete combustion (Panwar et al. 2012). In pyrolysis biomass is heated under high pressure and an inert atmosphere to generate oily compounds (Demirbaş 2000)

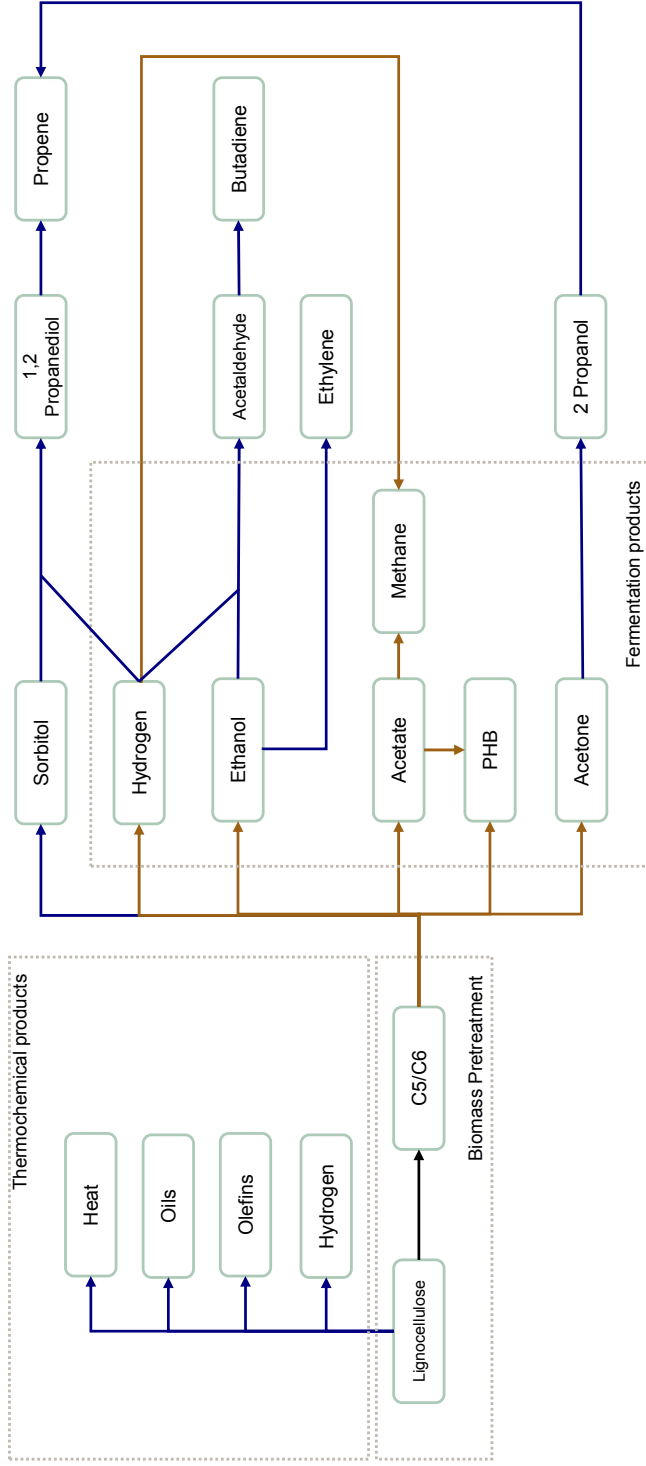

Figure 1 Potential products and processes in a biorefinery. Adapted from Cherubini & Strømman (2011), Menon & Rao (2012) and Venkata Mohan et al. (2016), Bronze arrows indicate fermentative processes while blue arrows signify chemical processes

1.4.2 Fermentation products

The pretreatment of lignocellulose results in the generation of monomeric sugars, which can be utilised as substrates for fermentation processes by microorganisms, thereby yielding various bio-based products (Kawaguchi et al. 2016). Various products can be generated from lignocellulose hydrolysates by an array of organisms such as bacteria, yeast, fungi and methanogen (Table 1).

Additionally, fermentation processes can be coupled in tandem for the simultaneous production of several products using sequential bioreactors. These sequential fermentation processes rely on using two separate bioreactors each containing different microorganisms, which either consume different substrates or utilise a metabolic product of the previous bioreactor. These sequential fermentation processes have been coupled with hydrogen dark fermentation allowing further fermentation of acetate into products such as methane or polyhydroxybutyrate (PHB) (Benemann 1996, Liu et al. 2006, Pawar et al. 2013, **Papers II and III**). Sequential fermentation can be undertaken to utilise different sugars when one of the product forming microorganisms cannot metabolise one or more of the sugars present in the lignocellulosic hydrolysate. This has been demonstrated by the co-production of ethanol and xylitol from corn stover using a two-step process. Initially, corn stover was fermented with *Saccharomyces cerevisiae* utilising glucose to yield ethanol, while a subsequent step produced xylitol from xylose with *Candida tropicalis* (Swain & Krishnan 2015).

Due to the variety of different sugars formed during hydrolysis of hemicellulose, a substantial amount of various sugars are produced, including pentoses such as xylose and arabinose (Kumar et al. 2009b). In wheat straw hydrolysate 30% of the total sugars are pentoses (**Paper II**). Therefore, the implementation of organisms capable of utilising a broad range of sugars is advantageous in a biorefinery system (Kumar et al. 2009b).

1.5 Hydrogen and biorefinery

Hydrogen has that attributes which could classify it as an environmentally ideal energy carrier. Hydrogen has a high energy density (142 MJ/kg) and is the only carbon-free fuel available, as the only end-product from combustion or when used in a hydrogen fuel cell is water vapour (Balat 2008). Hydrogen can be produced by a variety of mechanisms in a biorefinery, i.e. through thermochemical synthesis and via biological hydrogen production (Kleinert & Barth 2008, Levin et al. 2004). Biological hydrogen (biohydrogen) is hydrogen that is produced by certain microorganisms through several possible metabolic pathways (Chapter 2). Although, the vast majority of hydrogen is currently generated from fossil fuels or water splitting, biohydrogen is an emerging technology for the generation of

hydrogen (Balat 2008, Kapdan & Kargi 2006, Nikhil et al. 2017). Biohydrogen, particularly when yielded through dark fermentation, has been previously described as a potential nexus point within a biorefinery whereby both hydrogen and organic acids are yielded during hydrogen fermentation (Venkata Mohan et al. 2016). These organic acids can be further fermented into products such as methane and the bioplastic PHB (**Paper II and III**). Within a biorefinery, hydrogen can be utilised as an energy carrier or yield additional products through chemical processes, e.g. hydrogenolysis (Bozell & Petersen 2010).

Table 1 Fermentation products generated from different sources of lignocellulose and their potential industrial applications

Product	Lignocellulosic substrate	Organism	Potential use	Reference
2,3-butanediol	Corn stover	<i>Bacillus licheniformis</i>	Various bulk chemicals	Li et al. (2014)
Butanol	Napier Grass	<i>Clostridium acetobutylicum</i>	Fuel, Solvent	He et al. (2017)
Butyric acid	Wheat straw	<i>Clostridium tyrobutyricum</i>	Food additives, bioplastics	Baroi et al. (2015)
Citric Acid	Palm oil empty fruit bunches	<i>Aspergillus niger</i> IBO-103MNB	Food additive	Bari et al. (2009)
Fumaric Acid	Corn Straw	<i>Rhizopus oryzae</i>	Food additives polyester resins	Xu et al. (2010)
Hydrogen	Wheat straw	<i>Caldicellulosiraptor saccharolyticus/ owensensis</i>	Fuel, Reducing agent,	Paper II
Itaconic acid	Wheat chaff	<i>Aspergillus terreus</i>	Synthesis of polyesters	Krull et al. (2017)
Lactic acid	Vine shoot trimmings	<i>Lactobacillus pentosus</i>	Polylactic acid, food additives	Bustos et al. (2004)
Polyhydroxybutyrate	Soybean husk, sunflower husk, and wood straw	<i>Ralstonia eutropha</i>	Bioplastic	Saratale and Oh (2015)
Succinic Acid	Corn cob	<i>Corynebacterium glutamicum</i> NC-2	Precursor for plastics, resins, 1,4 butanediol	Wang et al. (2014)
Xylitol	Bamboo culm	<i>Candida magnoliae</i>	Food additive	Miura et al. (2013)

Beyond biorefinery, biohydrogen has the potential to be an ideal green fuel for transport and electricity generation (Meher Kotay & Das 2008). Hydrogen is also used in an array of industries as a reducing agent, including fertiliser production and the refinement of petroleum and metals (Hornung 2014, Luidold & Antrekowitsch 2007).

2. Biohydrogen

“I believe that water will one day be employed as fuel, that hydrogen and oxygen which constitute it, used singly or together, will furnish an inexhaustible source of heat and light, of an intensity of which coal is not capable” Jules Verne, 1874

Hydrogen is used in a variety of industrial processes and has great future potential as an energy carrier. Although, hydrogen is the most abundant element in the universe, hydrogen gas is only present in minute quantities (0.07%) in the atmosphere (Das & Veziroğlu 2001). The vast majority of hydrogen is derived from fossil fuels or through the process of water splitting (Balat & Balat 2009). An alternative to the current production methods is the sustainable production of hydrogen from lignocellulose feedstocks using microorganisms that can metabolically produce hydrogen.

2.1 Enzymes

All biological hydrogen production relies on two enzymes: hydrogenase and nitrogenase (Kovács et al. 2006). Hydrogenases are the most important group of enzymes for the production of biohydrogen. Hydrogenases catalyse the reversible reaction (eq. 1).



The directionality of this reaction is based on the redox potential of compounds interacting with the enzyme (Vignais & Billoud 2007). Hydrogenases are diverse in respect to their size and other attributes and can be classified into three distinct groups based upon the sequence similarities and metal content of their catalytic core: [NiFe]-, [FeFe]- and [Fe]- hydrogenases (Vignais & Billoud 2007, Vignais et al. 2001). [NiFe]- hydrogenases are found in bacteria and archaea whereas the majority of [Fe-Fe] hydrogenases occur in anaerobic bacteria and eukaryotes (Vignais & Billoud 2007). [Fe]- hydrogenases are rare and are only found in certain archaea such as *Methanocaldococcus jannaschii* (Pilak et al. 2006, Vignais & Billoud 2007). Hydrogenases are oxygen sensitive with complete inhibition of hydrogen production at oxygen concentrations as low as 1% (Lukey et al. 2011, Vignais & Billoud 2007). However, both native and engineered oxygen-tolerant

hydrogenases have been identified and developed (Burgdorf et al. 2005, Lukey et al. 2011). In addition, hydrogenases are subject to product inhibition at elevated hydrogen partial pressures (Kengen et al. 2009).

Hydrogen can be generated as a by-product of nitrogen fixation, whereby nitrogen gas (N_2) is converted to ammonia via a nitrogenase enzyme (Tamagnini et al. 2007). Biological production of hydrogen via nitrogenase is costly in terms of ATP, requiring at least 4 ATP molecules to form one H_2 molecule (Asada & Miyake 1999). Hydrogenases are superior to nitrogenases with regard to hydrogen production as hydrogenases allow for up to 1000 times greater hydrogen evolution than nitrogenases and are also ATP independent (Benemann 2000). Nevertheless, nitrogenases yield significant quantities of hydrogen due to large copy numbers of this enzyme being present in the cell (Kovács et al. 2006).

2.2 Mechanisms of biohydrogen production

Hydrogen can be produced metabolically through several different mechanisms. These can be divided into light-depend systems, such as direct biophotolysis, indirect photolysis and photofermentation, and light-independent fermentation, the so-called dark fermentation.

2.2.1 Direct biophotolysis

Direct biophotolysis is a process where hydrogen is generated photosynthetically by the biological splitting of water and is generally performed in anaerobic conditions by green algae (Brentner et al. 2010, Levin et al. 2004). This photosynthesis process relies on two photosystems: photosystem I (PSI) and photosystem II (PSII) (Das & Veziroğlu 2001). Light with an absorbance below 680 nm is absorbed by PSII that oxidises water into O_2 , protons and electrons. PSI absorbs light below 700 nm and produces reducing factors ($NAD(P)^+$) in order to permit the reduction of CO_2 . In direct biophotolysis electrons flow from PSII to PSI to the hydrogenase via the electron carrier ferredoxin (Das & Veziroğlu 2001, Oh et al. 2013).

During biophotolysis, 0.5 mole O_2 is produced per mole H_2 . However, the presence of O_2 negatively affects the production of hydrogen as O_2 irreversibly binds to and inhibits the Fe-Fe hydrogenases as well as acting as a transcriptional repressor for the expression of hydrogenase (Brentner et al. 2010). The great barrier to industrial hydrogen production from direct biophotolysis is the low volumetric productivity (Q_{H_2}) through this mechanism (Table 2) and the safety aspects of co-production of hydrogen and oxygen.

Table 2 Comparison of biohydrogen production via different mechanisms

Biohydrogen process	Organism	Temperature (°C)	Y_{H_2}	Q_{H_2} (mmol/L/h)	Reference
Direct biophotolysis	<i>Chlamydomonas reinhardtii</i>	25	Not stated	0.05 mmol/L/h	Kosourov et al. (2002)
Direct biophotolysis	<i>Chlamydomonas moewusii</i>	24	Not stated	0.005 mmol/L/h	Vargas et al. (2018)
Indirect biophotolysis	<i>Plectonema boryanum</i>	22	Not stated	0.02 mmol/L/h ^a	Huesemann et al. (2010)
Photofermentation	<i>Rhodospseudomonas palustris</i> and <i>Rhodobacter capsulatus</i>	30	Not stated	12.0 mmol/L/h ^b	Machado et al. (2018)
Photofermentation	<i>Rhodobacter capsulatus</i>	30 – 33	39% theoretical maximum	1.1 mmol/L/h	Özgül et al. (2010b)
Dark fermentation	<i>Enterobacter cloacae</i> IIT-BT 08	36	2.2 mol H ₂ /mol glucose	20.0 mmol/L/h	Das (2009), Kumar and Das (2000)
Dark fermentation	<i>Clostridium butyricum</i> CGS5	37	2.9 mol H ₂ /mol sucrose	5.8 mmol/L/h ^c	Chen et al. (2005)
Dark fermentation	Mixed consortium	70	2.47 mol H ₂ /mol glucose	2.1 mmol/L/h ^d	Kotsopoulos et al. (2006)
Dark fermentation	<i>Thermotoga elfii</i>	65	3.3 mol H ₂ /mol glucose	2.7 – 4.5 mmol/L/h	van Niel et al. (2002)
Dark fermentation	<i>Caldicellulosigraptor saccharolyticus</i>	70	2.4-3.4 mol H ₂ /mol hexose	6.2 – 13.0 mmol/L/h	de Vrije et al. (2009)

^a Calculated from 0.44 mL/L/h

^b Calculated from 287.39 mmol H₂/L/D

^c Calculated from 141 mL/h/L

^d Calculated based on a productivity of 11.15 mmol/d and a reactor volume of 220 mL

2.2.2 Indirect biophotolysis

Indirect biophotolysis relies on a similar mechanism as direct biophotolysis but avoids simultaneous O₂ and H₂ formation by the decoupling of photosynthesis and hydrogen formation (Benemann 1996). Indirect biophotolysis is a two-step process where an initial photosynthetic process produces oxygen and fixates carbon which is stored. The second step involves the anaerobic fermentation of this stored carbon into hydrogen (Hallenbeck 2012). This was demonstrated by Huesemann et al. (2010) who initially cultivating *Plectonema boryanum* with a photosynthesis phase (high intensity light) producing intracellular glycogen followed by a hydrogen generation phase requiring nitrogen depletion and reduction of light intensity.

2.2.3 Photofermentation

In photofermentation, biohydrogen is produced from organic substances, such as organic acids, by purple non-sulphur bacteria (Show & Lee 2013). Photofermentation primarily relies on the formation of hydrogen via a nitrogenase. Hydrogen can be generated as a side product of nitrogen fixation, or more significantly, in the absence of N₂ the nitrogenase acts as a hydrogenase, albeit with a specific activity an order of magnitude lower than that of a Ni-Fe hydrogenase (McKinlay & Harwood 2010, Weissman & Benemann 1977). In this system, excess NAD(P)H derived from the utilisation of sugars or organic acids in the central metabolism inhibits growth and are removed by the transfer of electrons to the photosystem (Hallenbeck 2011, McKinlay & Harwood 2010). These electrons are energised by light and are repeatedly cycled to create a proton gradient, that in turn generates both ATP and reduced ferredoxin that drive the nitrogenase reaction yielding hydrogen (Hallenbeck 2011). In photofermentation a maximum hydrogen yield (Y_{H2}) of 4 mol H₂ /mol acetate is possible (Uyar et al. 2009).

2.2.4 Dark fermentation

Although, light-dependent systems can yield hydrogen, they suffer from low Q_{H2} (Table 2), low light utilisation and inhibition from oxygen production, thereby, creating difficulty in industrial implementation for biohydrogen production (Nath & Das 2004). Alternatively, dark fermentation can be utilised to generate hydrogen independently of light by harnessing the metabolisms of particular obligate and facultative anaerobic bacteria or archaea under anoxic conditions (Nandi & Sengupta 1998, Ntaikou et al. 2010). Hydrogen is formed by certain microorganisms due to a lack of external electron acceptors hence requiring the disposal of excess electrons by the reduction of protons (Gray & Gest 1965). There are two possible mechanisms in which hydrogen can be produced via dark fermentation (Fig. 2). In one pathway pyruvate is decarboxylated into acetyl-coA

yielding reduced ferredoxin (Fd_{red}) which is used as an electron donor for a ferredoxin hydrogenase. The second mechanism involves the formation of formate and acetyl-CoA from pyruvate and CoA. Formate is subsequently broken down into H_2 and CO_2 by the formate hydrogenlyase complex (Khanna & Das 2013). Initially, formate is dehydrogenated into CO_2 , protons and electrons followed by conversion to hydrogen using a hydrogenase subunit of this complex (McDowall et al. 2014, Thauer et al. 1977)

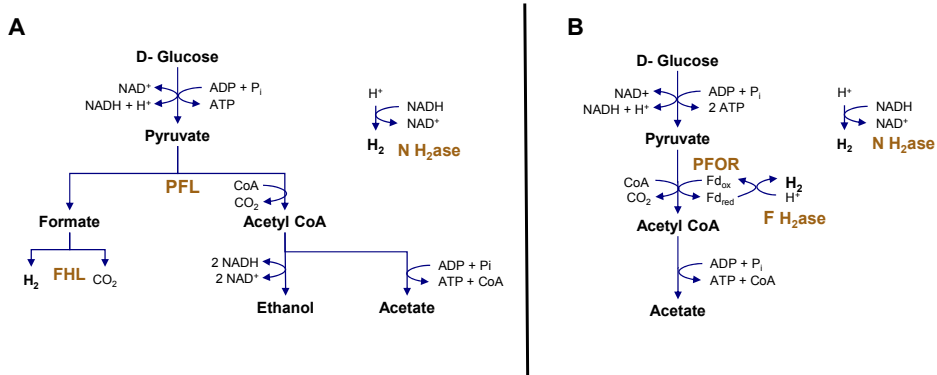

Figure 2 Metabolic pathways for hydrogen production via dark fermentation via formation of formate (A) and ferredoxin (B). F H_2ase , ferredoxin hydrogenase; FHL, formate hydrogenlyase; N H_2ase , NADH dependent hydrogenase, PFL, pyruvate formate lyase; PFOR, pyruvate:ferredoxin oxidoreductase. Adapted from Carere et al. (2012), Hallenbeck (2009) and Liu et al. (2017)

In addition to hydrogen, dark fermentation must yield other metabolic products to synthesise ATP (acetate, butyrate) or to oxidise NADH (butanol, butyrate, ethanol and lactate) (Hallenbeck & Ghosh 2009). Alternatively, NADH can be further oxidised into H_2 and NAD^+ (Jungermann et al. 1973). The maximum Y_{H_2} from glucose (Thauer limit) is 4 mol H_2 /mol hexose when acetate is produced and 2 mol H_2 /mol hexose when butyrate is yielded as a by-product (Jungermann et al. 1973, Thauer et al. 1977).

Dark fermentation and photofermentation can be combined into a two-step process where initial dark fermentation yields hydrogen and organic acids (acetate and butyrate) and the subsequent photofermentative reaction generates hydrogen from these organic acids. A combined dark fermentation and photofermentation process has a theoretical maximum Y_{H_2} of 12 H_2 /mol hexose (Hallenbeck & Benemann 2002, Keasling et al. 1998). In practice, the greatest reported Y_{H_2} from a combined process is 9.4 H_2 mol/mol glucose consisting of a dark fermentation with *T. neapolitana* followed by photofermentation with *Rhodospseudomonas palustris* (Dipasquale et al. 2015).

2.2.5 Dark fermentation cultures

Cultures for biohydrogen production can be divided into defined mono-, co-cultures or undefined enrichment cultures (Pawar & Niel 2013). Mono-cultures refer to fermentation processes where a single known strain is employed to produce hydrogen. Hydrogen can be produced by mono-cultures of numerous species of bacteria (Table 2). As a dark fermentation mono-culture relies on one organism; the limitations of such a process are based on the inherent abilities or idiosyncrasies of the organism, i.e. sugar utilisation profile, Q_{H_2} , oxygen tolerance and nutritional requirements (Elsharnouby et al. 2013).

Co-cultures on the other hand, involve the implementation of two or more organisms in a fermentation but unlike an undefined enriched culture, the identity of organisms are known. The implementation of co-cultures rather than mono-cultures can result in an overall improvement in the production of hydrogen compared to mono-cultures with regard to oxygen tolerance, Q_{H_2} , Y_{H_2} and substrate utilisation (Elsharnouby et al. 2013). Co-cultures of the obligate anaerobic bacterium *Clostridium butyricum* and facultative anaerobe *Enterobacter aerogenes* allowed for greater tolerance to oxygen as *E. aerogenes* was capable of consuming oxygen within the bioreactor. Additionally, as this organism could facilitate the formation of an anaerobic environment, the reducing agent L-cysteine could be omitted (Yokoi et al. 1998). The co-culture of different members of the *Caldicellulosiruptor* genus have been demonstrated to permit greater Q_{H_2} and biofilm formation (Pawar et al. 2015, Zeidan et al. 2010).

Co-cultures can also facilitate a wider range of sugar utilisation from lignocellulosic hydrolysate or permit enhanced degradation of lignocellulose (Elsharnouby et al. 2013). Moreover, co-culturing of microorganisms may have a synergistic effect compared to the respective species in mono-culture. A co-culture of *Clostridium thermocellum* JN4 and *Thermoanaerobacterium thermosaccharolyticum* GD17 displayed a synergistic effect whereby hemicellulose could be consumed, despite neither organism being capable of hemicellulose utilisation in mono-culture. This occurred as the cellulose complex of *Cl. thermocellum* JN4 can also degrade xylan to xylose, however, *Cl. thermocellum* JN4 is unable to metabolise xylose. *T. thermosaccharolyticum* GD17 on the other hand, can utilise xylose but is unable to degrade xylan (Liu et al. 2008). Therefore, xylose yielded by the degradation of xylan to xylose by *Cl. thermocellum* JN4 could be used as a substrate for *T. thermosaccharolyticum* GD17.

An undefined culture is a complex mixture of microorganisms where the identity of the organisms present in the culture is unknown and can be derived from sources such as methanogenic sludge (Svensson et al. 1992). The enrichment of hydrogen producers in undefined methanogenic sludge requires the removal of hydrogen consuming organisms by the treatment of the sludge with temperatures at or above

90°C, exposure to high or low pH or the addition of compounds that inhibit methanogenesis such as 2-bromoethanesulfonic acid (Chen et al. 2002, Dessi et al. 2017, Lay et al. 1999, Zehnder & Brock 1979). As mixed consortia consists of diverse microbial populations, they have the advantage of undergoing a variety of metabolic reactions, such as simultaneous sugar consumption and cycling of nutrients, that may not be possible for a defined mono-culture (Brenner et al. 2008, Paerl & Pinckney 1996). These undefined cultures also demonstrate a high degree of robustness due to the wide variety of species present and as such can adapt to low substrate concentration by shifting the population dynamics within the consortium (LaPara et al. 2002). The advantage of this robustness is that these undefined consortia can be utilised in systems with varying operating parameters. A study by Goud et al. (2012) illustrated that an enriched hydrogen producing consortium can adapt to internal reactor pH as diverse as 4.1 and 7.2.

As these consortia comprise of diverse microbial communities, it is possible to adapt these cultures to operate in both mesophilic and thermophilic conditions. It has been demonstrated that hydrogen production from activated sludge with a xylose substrate could be undertaken at 37°C, 55°C and 70°C using the same culture (Dessi et al. 2017). The adaptation of undefined hydrogen cultures to different temperatures results in a marked alteration to the population dynamics with *Clostridium* becoming dominant at mesophilic temperatures whereas at elevated temperatures *Bacillus* and *Thermoanaerobacter* are majority genera (Carrillo-Reyes et al. 2016, Karadag & Puhakka 2010). Complex consortia can also promote biofilm formation and possess a greater resistance to contamination (Burmølle et al. 2006). However, undefined cultures generally result in lower Y_{H_2} compared to mono- or co-cultures (Pawar 2014). A study by Chaganti et al. (2012) demonstrated that the reduction in Y_{H_2} in mesophilic cultures may occur due to the presence of hydrogen-consuming organisms within the consortium.

2.2.6 Thermophilic fermentation

Hydrogen can be generated through dark fermentation by species of bacteria and archaea at thermophilic, extreme thermophilic and hyperthermophilic temperatures (Levin et al. 2004, Verhaart et al. 2010). At elevated temperatures biological production of hydrogen is more thermodynamically favourable than at mesophilic temperatures with the process also becoming less sensitive to hydrogen partial pressures (Stams 1994). The NADH and the Fd_{red} pathways are sensitive to hydrogen partial pressures with the NADH pathway more sensitive to both parameters than that of the Fd_{red} pathway as formation of hydrogen via NADH is less thermodynamically favourable (Eq. 2 and 3) (Stams 1994).

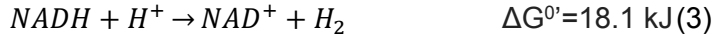
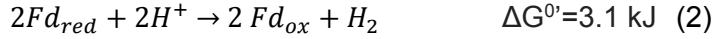

As the generation of hydrogen from NADH is more unfavourable at lower temperatures, mesophilic organisms generally have a Y_{H_2} of approximately 2 mol H_2 / mol hexose (Chou et al. 2008). On the other hand, as hydrogen production at higher temperatures is more exergonic via both NADH and Fd_{red} , thermophilic organisms can potentially possess a Y_{H_2} approaching the Thauer limit of 4 mol H_2 /mol hexose (Kengen et al. 2009, Thauer et al. 1977, Willquist et al. 2010). In addition to a high Y_{H_2} , a large number of studied thermophilic hydrogen producers are capable of metabolising a wide array of sugars or direct consumption of cellulose and hemicellulose (Blumer-Schuette et al. 2008).

The cultivation of thermophilic bacteria also has the advantage of reducing the probability of contamination during fermentation as the high temperature precludes growth by a majority of microbial species (Kodama & Minoda 1977). Although contamination is less likely, contamination of thermophilic cultures of *Caldicellulosiruptor saccharolyticus* with a cultivation temperature of 73°C has been observed when operated in a non-sterile trickle bed. However, in this case the hydrogen producer *C. saccharolyticus* remained as the dominant species in the cultivation despite the contamination (van Groenestijn et al. 2009).

3. *Caldicellulosiruptor*

Caldicellulosiruptor is a genus of gram-positive, obligatory anaerobic bacteria (Rainey et al. 1994, Schleifer 2009). The genus *Caldicellulosiruptor* contains extreme thermophilic species with the optimum growth temperature of most species above 70°C. To date a total of 14 species of *Caldicellulosiruptor* have been identified in literature (Table 3), of which 9 have standing in prokaryote nomenclature (Parte 2014). A majority of *Caldicellulosiruptor* species have been isolated from thermal hot springs. The genus has been demonstrated to be a potential candidate for the industrial production of biohydrogen due to its ability to yield hydrogen close to the maximum stoichiometric ratio of 4 mol H₂/mol hexose and its use of a broad spectrum of carbohydrates (Rainey et al. 1994, van Niel et al. 2002). Although, there are a total of 14 species in the genus *Caldicellulosiruptor*, a great deal of research has focused on two species *C. saccharolyticus* and *C. bescii*.

3.1 Substrate utilisation

The majority of species belonging to the genus *Caldicellulosiruptor*, including *C. saccharolyticus*, are capable of direct utilisation of lignocellulose, namely the cellulose and hemicellulose fractions (Rainey et al. 1994, Schleifer 2009). *C. saccharolyticus* possesses a multitude of glycoside hydrolases capable of degrading multiple polymeric sugars. In *C. saccharolyticus*, these enzymes are either secreted, membrane bound or located in the cytoplasm thereby degrading imported oligosaccharides (VanFossen et al. 2011). Unusually, compared to other cellulolytic Clostridia, *Caldicellulosiruptor* does not possess a cellulosome but contain multi-functional cellulases with multiple catalytic domains specific to different components of lignocellulose (Bergquist et al. 1999, Brunecky et al. 2013, Dam et al. 2011). Although, most members of the *Caldicellulosiruptor* genus demonstrate growth when microcrystalline cellulose (Avicel) is employed as a substrate, this is species dependent with significantly less growth by *C. owensensis* than *C. saccharolyticus*. This is due to the variation of the glycoside hydrolase profile of each species with *C. owensensis* possessing less cellulose glycoside

Table 3 Comparison of the species of the *Caldicellulosiruptor* genus

Species	Area of isolation	Temperature range (°C)	Optimum temperature (°C)	pH range	pH optimum	Major metabolites	Reference
<i>C. acetigenus</i> ^a	Hveragerdi-Hengill geothermal area, Iceland	50-78	65-88	5.2-8.5	7.0	Lactate	Nielsen et al. (1993), Onyienwoke et al. (2006)
<i>C. bescii</i> ^b	Kamchatka, Russia	42-90	78-80	Not stated	7.1-7.3	Acetate, Lactate	Yang et al. (2010)
<i>C. changbaiensis</i>	Changbai Mountains, China	40-90	75	5.6-8.6	7.8	Acetate, Lactate	Bing et al. (2015)
<i>C. danielli</i> ^c	Waimangu, New Zealand	Not stated	Not stated	Not stated	Not stated	Not stated	Lee et al. (2018), Lee et al. (2015)
<i>C. hydrothermalis</i>	Geyser Valley, Kamchatka, Russia	50-80	75	6.0-8.0	7.0	Lactate and Acetate	Miroshnichenko et al. (2008)
<i>C. kristjansonii</i>	Slightly alkaline, hot spring, Iceland	42-82	78	5.8-8.0	7.0	Acetate	Bredholt et al. (1999)
<i>C. kronotskyensis</i>	Geyser Valley, Kamchatka, Russia	45-82	70	6.0-8.0	7.0	Lactate	Miroshnichenko et al. (2008)
<i>C. lactoaceticus</i>	Hveragerdi area on Iceland.	50-78	68	5.8-8.2	7.0	Lactate and Acetate	Mladenovska et al. (1995)
<i>C. morganii</i> ^d	Rotorua, New Zealand	Not stated	Not stated	Not stated	Not stated	Not stated	Lee et al. (2018), Lee et al. (2015)
<i>C. naganoensis</i> ^e	Nagano Prefecture, Japan	50-85	75	6.0-9.5	8.0	Acetate	Lee et al. (2018), Taya et al. (1988)
<i>C. obsidiensis</i>	Obsidian Pool, Yellowstone National Park, United States	55-75	78	6.0-8.0	6.7-7.0	Acetate	Hamilton-Brehm et al. (2010)
<i>C. owensensis</i>	Owens Lake, California, United States	50-80	75	5.5-9.0	7.5	Lactate and Acetate	Huang et al. (1998)
<i>C. saccharolyticus</i>	Hot spring, New Zealand	45-80	70	5.5-8.0	7.0	Acetate	Rainey et al. (1994)
<i>Caldicellulosiruptor</i> sp. F32	Compost, China	55-80	75	5.0-8.0	7.0	Lactate and Acetate	Ying et al. (2013)

^a Originally named *Thermoanaerobium acetigenum*

^b Originally named *Anaerocellum thermophilum*

^c Previous designation *Caldicellulosiruptor* sp. strain Wai35.B

hydrolases but more xylan glycoside hydrolases than *C. saccharolyticus* (Blumer-Schuette et al. 2010). *Caldicellulosiruptor* can also directly adhere to cellulose through by utilising unique proteins known as tāpirins (Blumer-Schuette et al. 2015). These proteins are most likely found on the cell surface of *Caldicellulosiruptor* and facilitate close proximity to the lignocellulose substrate, thereby, increasing the efficiency of the glycoside hydrolases (Lee et al., 2018b). The ability of *Caldicellulosiruptor* to directly catabolise lignocellulose makes it a promising candidate for integration into biorefinery as it would permit consolidated bioprocess, removing the necessity for biomass pretreatment and enzymatic hydrolysis.

One of the defining features of the *Caldicellulosiruptor* genus (with the exception of *C. lactoaceticus*) is the ability to utilise a wide array of sugars and sugar alcohols (Schleifer 2009). The bacterium, *C. saccharolyticus* can metabolise numerous sugars derived from lignocellulose material, including hexoses such as glucose, galactose and mannose as well as pentoses such as xylose and arabinose (Rainey et al. 1994). The importation of soluble sugars (mono-, di-oligosaccharides) occurs via a host of ABC transporters at the expense of ATP (van de Werken et al. 2008). *C. saccharolyticus* possesses at least 177 genes encoding for ABC transporters of which 24 have been identified as having specificity to one or more sugars. Several ABC transporters are proposed to have the capability to import a broad spectrum of monosaccharides (van de Werken et al. 2008, VanFossen et al. 2009).

In *C. saccharolyticus*, multiple carbon sources are simultaneously metabolised without catabolite repression (van de Werken et al. 2008). When cultivated on a sugar mixture, *C. saccharolyticus* will consume each sugar concurrently but at a different rates with a general preference for pentoses (fructose > arabinose > xylose > mannose > glucose). However, it must be noted that the order of sugar preference varies depending on the sugar mixtures employed (VanFossen et al. 2009). Although *C. saccharolyticus* can co-utilise numerous sugars while lacking catabolite repression, a biphasic production of hydrogen can be observed in certain circumstances (**Paper IV**).

The ability of *Caldicellulosiruptor* to use a wide range of sugars without catabolite repression is advantageous within a biorefinery setting as the ability to metabolise multiple sugars simultaneously permits utilisation for both the cellulose and hemicellulose fractions of lignocellulose. Moreover, the lack of carbon catabolite repression increases the efficiency as sequential sugar utilisation is not present (Kim et al. 2010).

3.2 Hydrogen production

The mechanism by which *Caldicellulosiruptor* produces hydrogen has yet to be fully resolved. It has been previously reported that *C. saccharolyticus* possesses two hydrogenases, a [Fe-Fe]¹ hydrogenase and a [Ni-Fe] hydrogenase. The [Fe-Fe] hydrogenase is hypothesised to generate H₂ by the oxidation of NADH, whereas the Ni-Fe hydrogenase produces H₂ from Fd_{red} and likely acts as a proton pump to create a proton motive force (van de Werken et al. 2008). Additionally, *C. bescii* also possesses a [Ni-Fe] and an [Fe-Fe] hydrogenase. In this system, the [Ni-Fe] hydrogenase uses Fd_{red} and acts as a proton pump similar to that described in *C. saccharolyticus* (Cha et al. 2013, van de Werken et al. 2008). The [Fe-Fe] hydrogenase in *C. bescii* is, however, a bifurcating enzyme, simultaneously utilising a 1:1 ratio of NAD(P)H and Fd_{red} to produce H₂. The deletion of the Ni-Fe hydrogenase in *C. bescii* results in an increase in available NADH, nevertheless, no observable decrease in H₂ production occurs, indicating that this hydrogenase is not an essential enzyme for H₂ production (Cha et al. 2013). Bioinformatics studies have postulated that *C. saccharolyticus* could possess a bifurcating [Fe-Fe] hydrogenase similar to *C. bescii* rather than the aforementioned two-enzyme system (Carere et al. 2012, Willquist et al. 2011).

Glycolysis in *C. saccharolyticus* is carried out exclusively by the Embden Meyerhof pathway whereby all sugars with the exception of methylpentoses such as rhamnose and fucose are converted to pyruvate via glyceraldehyde 3-phosphate (Bielen et al. 2013a, de Vrije et al. 2007, Ingvadottir et al. 2017). In an optimal process where the Thauer limit of 4 H₂ mol/mol hexose is obtained, the NADH necessary for hydrogen formation via the [Fe-Fe] hydrogenase is generated by the conversion of GAP to pyruvate. The Fd_{red} required by the Ni-Fe hydrogenase is coupled to the oxidation of pyruvate to acetyl-CoA by the enzyme ferredoxin oxidoreductase (Fig. 2) (Bielen et al. 2013a)

3.2.1 Hydrogen production from lignocellulose

Caldicellulosiruptor has the potential to be integrated into a biorefinery system given its capacity to produce hydrogen close to the theoretical maximum Y_{H₂} while co-consuming multiple sugars, including hexoses and pentoses. The production of hydrogen via *Caldicellulosiruptor* has been studied with a variety of different lignocellulosic materials, both hydrolysates and direct use of lignocellulose (Table 4). In addition, as acetate is the main metabolic by-product, the effluent of

¹ The original paper by van de Werken et al. (2008) refer to this enzyme as an [Fe-] only hydrogenase, however, due to a change in terminology this type of enzyme is now an [Fe-Fe] hydrogenase

Table 4 Cultivation of *Caldicellulosiruptor* on various lignocellulose substrates

Organism	Substrate	Sugar Concentration (g/L)*	Fermentation mode	Y_{H_2} (mol/mol hexose)	Q_{H_2} (mmol/L/h)	Reference
<i>C. saccharolyticus</i>	Miscanthus hydrolysate	G: 7.0; X: 2.7; A 0.3	Batch	3.4	12.6	de Vrije et al. (2009)
<i>C. saccharolyticus</i>	Miscanthus hydrolysate	G: 9.8; X: 3.8; A 0.4	Batch	3.3	10.4	de Vrije et al. (2009)
<i>C. saccharolyticus</i>	Miscanthus hydrolysate	G: 19.6; X: 7.5; A 0.9	Batch	2.4	6.2	de Vrije et al. (2009)
<i>C. saccharolyticus</i>	Sweet sorghum bagasse hydrolysate	G: 6.1 X: 2.3 A 0.3	Batch	2.6	10.6	Panagiotopoulos et al. (2010)
<i>C. saccharolyticus</i>	Sweet sorghum bagasse hydrolysate	G: 11.1 X: 7.5 A 0.9	Batch	2.8	10.2	Panagiotopoulos et al. (2010)
<i>C. saccharolyticus</i>	Wheat straw hydrolysate	G: 6.7 X: 3.7 A 0.4	Continuous D = 0.05 h ⁻¹	3.43	8.7	Pawar et al. (2013)
<i>C. saccharolyticus</i>	Wheat straw hydrolysate	G: 6.7 X: 3.7 A 0.4	Continuous D = 0.15 h ⁻¹	2.08	8.8	Pawar et al. (2013)
<i>C. saccharolyticus</i>	Potato peel hydrolysate	G: 11	Batch	3.4	16.4	Mars et al. (2010)
<i>C. saccharolyticus</i>	Potato peel hydrolysate	G: 30	Batch	1.7	10.2	Mars et al. (2010)
<i>C. saccharolyticus</i>	Potato peel untreated	G: 10	Batch	3.5	13.3	Mars et al. (2010)
<i>C. saccharolyticus</i>	Potato peel untreated	G: 31	Batch	1.1	9.3	Mars et al. (2010)
<i>C. saccharolyticus</i>	Switchgrass untreated	3% switchgrass	Batch	Not stated	0.15	Talluri et al. (2013)
<i>C. saccharolyticus</i>	Wheat straw hydrolysate	G:18.3 X: 8.2 A: 0.6	Continuous D = 0.05 h ⁻¹	1.8	6.7	Paper II
<i>C. saccharolyticus</i>	Wheat straw / lucerne hydrolysate	G: 14.5 X: 6.3 A: 0.4	Continuous D = 0.05 h ⁻¹	1.9	4.2	Paper II

* Glucose, G; Xylose, X; Arabinose, A.

Caldicellulosiruptor fermentations can be utilised to yield additional products. One possible option is to employ a subsequent photofermentation step after dark fermentation with *Caldicellulosiruptor* to increase the Y_{H_2} from the process. When molasses was employed in a two-step process with *C. saccharolyticus* and *Rhodobacter capsulatus* a total Y_{H_2} of 6.85 mol H_2 /mol hexose could be obtained (Özgür et al. 2010a, Özgür et al. 2010b). The effluent from dark fermentation with *C. saccharolyticus* has also been investigated for methane production via methanogenic consortia and the production of the bioplastic PHB through cultivation with *Ralstonia eutropha* (Pawar et al. 2013, **Papers II and III**)

The pretreatment of lignocellulose also yields a large number of compounds that can inhibit fermentation, such as HMF, furfural and phenolics derived from lignin (Palmqvist & Hahn-Hägerdal 2000). *C. saccharolyticus* has been previously demonstrated to be inhibited by HMF and furfural, with a 50% inhibition at concentrations between 1 and 2 g/L of either compound (de Vrije et al. 2009). A study by de Vrije et al. (2010) focused on the generation of hydrogen from *C. saccharolyticus* from *Miscanthus* hydrolysate pretreated with heated NaOH followed by enzymatic hydrolysis. *C. saccharolyticus* was batch cultivated at varying concentrations of the hydrolysate. When compared to defined medium containing the corresponding concentration of sugars to the hydrolysate, no significant differences in either Y_{H_2} or Q_{H_2} were observed with the exception of 28 g/L of hydrolysate. At this concentration, the Y_{H_2} did not deviate substantially compared to the corresponding cultivation on a pure sugar mixture; however, the Q_{H_2} was reduced from 9.7 to 6.2 mmol/L/h when hydrolysate was used as a substrate. On the other hand, when cultivated on wheat straw hydrolysate pretreated with steam explosion followed by enzymatic hydrolysis, *Caldicellulosiruptor* demonstrated both higher cell mass and hydrogen productivities in comparison to a defined medium (Pawar et al. 2013, **Paper III**).

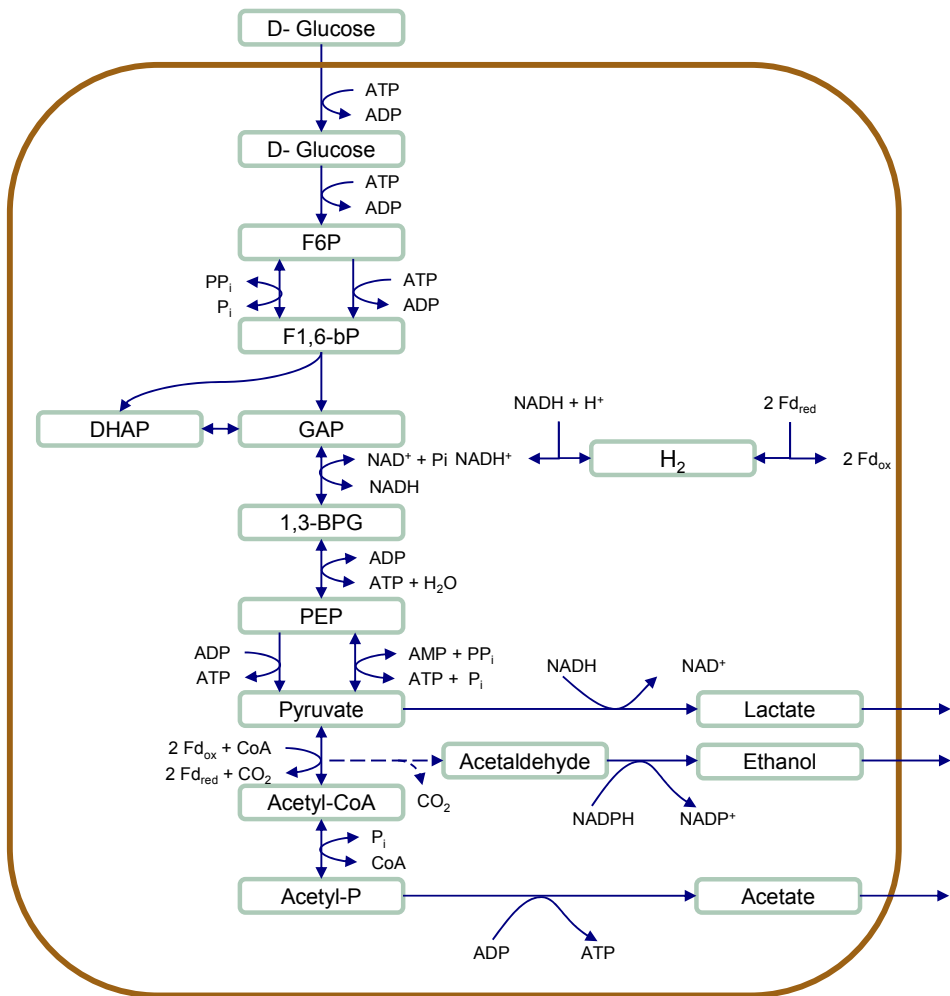

Figure 3 Schematic illustration of the Embden Meyerhof pathway in *C. saccharolyticus*. Dotted lines indicate that the enzyme(s) belonging to the ethanol metabolic pathway have not yet been established. DHAP; Dihydroxyacetone phosphate; F6P, fructose 6-phosphate; F1,6-Bp, Fructose 1,6 bisphosphate; GAP, D-glyceraldehyde 3-phosphate; PEP, Phosphoenolpyruvate; PPi, Pyrophosphate; 1,3-BPG, 1,3-Bisphosphoglycerate. This illustration was adapted from Bielen et al. (2013a)

3.3 Limitations of *Caldicellulosiruptor*

Although, *Caldicellulosiruptor* possesses many attributes of a promising hydrogen producer in an industrial process, such as a wide substrate utilisation and high Y_{H_2} there are several hurdles that need to be overcome to make such a process both technically and economically feasible.

3.3.1 Hydrogen partial pressure

The generation of biohydrogen can suffer from product inhibition by the presence of elevated hydrogen concentrations (Bielen et al. 2013b, Levin et al. 2004, Willquist et al. 2011). *C. saccharolyticus* can tolerate hydrogen partial pressures up to 67 kPa. However, with increasing hydrogen concentrations, the carbon flux is redirected from acetate towards lactate and ethanol, consequently, reducing Y_{H_2} . At these high partial pressures Y_{H_2} is reduced from 3.5 to 1.8 mol/mol hexose with a significant metabolic shift to lactate and ethanol formation (Willquist et al. 2011). This is likely due to the sensitivity of the NADH dependent hydrogenase, as hydrogen produced via the NADH pathway is less thermodynamically favourable, particularly at elevated hydrogen partial pressures (Kengen et al. 2009). Lactate formation is initiated when hydrogen partial pressures reach 2.1 kPa (Willquist et al. 2011). In *C. saccharolyticus*, the ratio between NADH and NAD^+ plays an essential role in lactate formation with elevated concentrations of NADH increasing lactate yield while NAD^+ acts as a competitive inhibitor to the lactate dehydrogenase (Willquist & van Niel 2010).

As hydrogen is poorly soluble in water, the supersaturation of hydrogen in the liquid phase can occur during biological hydrogen production and has been previously observed to exceed the equilibrium concentration (Beckers et al. 2015, Kraemer & Bagley 2006). The supersaturation has been shown to inhibit both mesophilic and thermophilic hydrogen production at 70°C (Kraemer & Bagley 2006, Ljunggren et al. 2011b, Zhang et al. 2013). In *C. saccharolyticus* saturation can range from 4.2 to 52 times that of equilibrium (Ljunggren et al. 2011b).

3.3.2 Osmolarity

C. saccharolyticus is also relatively sensitive to elevated concentrations of solutes with a critical osmolarity of between 0.27 and 0.29 Osmol/kg (Ljunggren et al. 2011b). Additionally, above a concentration of 0.22 Osmol/kg, growth inhibition and cell lysis of *C. saccharolyticus* arises (Willquist et al. 2009). A reduction in Y_{H_2} under high osmolarity conditions due to a metabolic shift of carbon towards

lactate also occurs. Similar osmolarity-based inhibition has been observed in *C. bescii* (Farkas et al. 2013).

When a bacterium is exposed to a hyperosmotic stress, a rapid loss of water from the cytosol occurs (Kempf & Bremer 1998). Bacteria can adapt to osmotic stress by the accumulation of ions, as in the case of halophiles, or by the synthesis and accumulation of compounds known as compatible solutes (Brown 1976, Sleator & Hill 2002). Compatible solutes (osmoprotectants) are compounds that are highly soluble and carry no net charge at physiological conditions. Compatible solutes protect against osmotic stress by balancing the osmolarity between the cytosol and the exterior or the cell (Kempf & Bremer 1998). Additionally, compatible solutes also stabilise enzyme activities at elevated osmolarities (Sleator & Hill 2002). Bioinformatics studies of *C. saccharolyticus* and *C. owensensis* indicate that these species lack the ability to synthesise various compatible solutes with the exception of the amino acids glutamate and proline (Willquist et al. 2009, **Paper I**).

The cultivation of *Caldicellulosiruptor* with concentrated hydrolysates generally results in a reduced Y_{H_2} (Table 4) with *C. saccharolyticus* incapable of growth in wheat straw hydrolysate concentrations above 20% (Pawar et al. 2013). The requirement for substrate dilution invariably increases water demand and hence requires additional heating leading to increased process costs (Foglia et al. 2010). Furthermore, low substrate concentrations can create difficulties in downstream processes. A techno-economic analysis by Ljunggren and Zacchi (2010a) demonstrated that low substrate concentrations would pose a great challenge in the design of a coupled *C. saccharolyticus* dark fermentation and anaerobic digestion process. Due to the dilute nature of the dark fermentation effluent, the anaerobic digestion process would either employ a high organic loading rate that may lead to cell wash out or a larger reactor size at low organic loading rates. Additionally, increasing the substrate concentration by a factor of two would reduce the process costs by 10% (Ljunggren & Zacchi 2010b).

3.3.3 Volumetric hydrogen productivity

Caldicellulosiruptor has many attributes of an ideal candidate for industrial exploitation, such as a high Y_{H_2} , wide substrate palette and a lack of catabolite repression. However, one of the greatest barriers to industrial application of *Caldicellulosiruptor* is its low Q_{H_2} (Ljunggren et al. 2011a, Urbaniec & Grabarczyk 2014). *Caldicellulosiruptor* like many thermophilic hydrogen producers reach a low cell density during cultivation (Chou et al., 2008). Although, *Caldicellulosiruptor* may yield hydrogen close to the Thauer limit, this low cell density limits the overall quantity of hydrogen produced. To date, the highest recorded Q_{H_2} for *Caldicellulosiruptor* is 22 mmol/L/h (van Groenestijn et al. 2009). A model by Ljunggren and Zacchi (2010b) indicated that to reach industrial

viability, a coupled dark fermentation and photofermentation would require a Q_{H_2} of 50 mmol/L/h with a higher substrate concentration.

3.3.4 Substrate costs

The necessity to supplement *Caldicellulosiruptor* fermentation processes with compounds required for growth such as yeast extract and phosphate buffer would greatly increase the financial expense of an industrial process (Ljunggren et al. 2011a). *C. saccharolyticus* can be cultivated without the addition of yeast extract or amino acids but requires vitamin supplementation when yeast extract is omitted (Willquist & van Niel 2012). *Caldicellulosiruptor* produces acetate (or lactate) during fermentation thereby lowering pH. As most species of *Caldicellulosiruptor* do not grow below pH 6.0 (Table 3), pH must be maintained through use of buffering and caustic agents. However, the addition of such agents to a process involving *Caldicellulosiruptor* is a high financial burden and would constitute more than 50% of the total process costs (Ljunggren et al. 2011a).

4. Improvement of hydrogen production by *Caldicellulosiruptor*

As discussed in Chapter 3, the genus *Caldicellulosiruptor* possesses many advantageous properties that would be suitable for its implementation into a biorefinery system i.e. high Y_{H_2} , ability to utilise a wide range of substrates and the lack of catabolite repression. Nevertheless, barriers such as low Q_{H_2} , osmosensitivity and the financial expense of the fermentation process limit the applicability of this genus to an industrial setting. The strategies discussed in this chapter were employed to overcome these limitations and progress *Caldicellulosiruptor* towards becoming a viable option for biorefinery by techniques such as strain improvement, integration of fermentation processes and the reduction of nutrient addition thereby reducing financial costs. It is expected that a combination of these approaches may synergistically lead to improved Q_{H_2} , lower costs and greater feasibility of the biohydrogen process within a biorefinery.

4.1 Strain improvement

One of the greatest limitations to future commercial exploitation of *Caldicellulosiruptor* is its inability to grow on concentrated media due to its susceptibility to elevated osmolarities. One technique for overcoming this limitation is to improve *Caldicellulosiruptor* strains to tolerate higher osmotic potentials.

4.1.1 Adaptive laboratory evolution

Adaptive laboratory evolution (ALE) is a strain development technique that relies on evolutionary adaption conducted under controlled laboratory conditions in order to develop novel strains with improved phenotypes. During ALE, an organism is cultivated under a particular stress condition for a prolonged period of time, either through continuous or sequential batch cultivations. The stress applied to the organism acts as a selective pressure, thereby driving the evolution of the organism towards a desirable phenotype. This change in phenotype develops due

to genomic mutations such as single point mutations, insertion and deletions and movement of transposable elements within the genome (Dragosits & Mattanovich 2013). ALE has been extensively studied in food technology, notably with the adaption of *Lactobacillus* strains to tolerate higher acid conditions and reduce biofilm formation, i.e. to avoid reactor fouling) (Johansen 2018). The principles of ALE have been applied to several hydrogen producing bacteria including *Clostridium tyrobutyricum*, *Thermotoga maritima* and *Caldicellulosiruptor* ssp. The mesophilic hydrogen producer *C. tyrobutyricum* has been previously adapted to grow on wheat straw hydrolysate concentrations of up to 80%, compared to the wild type tolerance of 10%. This was accomplished by sequential batch adaption to incrementally increasing wheat straw hydrolysate concentrations (Baroi et al. 2015). The thermophilic hydrogen producer *T. maritima* was capable of greater glucose consumption rates when adapted to media with increased glucose concentrations over 120 generations. Additionally, the adaption of *T. maritima* resulted in an increased growth rate and cell mass (Latif et al. 2015). ALE has been applied to the *Caldicellulosiruptor* species, *C. bescii*, *C. saccharolyticus* and *C. hydrothermalis*, to develop uracil auxotrophic strains of these organisms by the spontaneous deletion of the *pyrF* gene (Chung et al. 2012, Groom et al. 2014, Pawar 2014).

In the native environments of *Caldicellulosiruptor*, low concentrations of solutes and free sugars are present and therefore *Caldicellulosiruptor* has adapted to catabolise large polymeric sugars such as cellulose and hemicellulose at low osmotic conditions (Blumer-Schuetz et al. 2008, Sissons et al. 1987). This predilection for low osmolarity limits the ability to cultivate *Caldicellulosiruptor* on concentrated hydrolysates and therefore hinders the industrial application of *Caldicellulosiruptor* (Ljunggren et al. 2011b, Ljunggren & Zacchi 2010a, Willquist et al. 2010). Previously, osmotolerant strains of *C. saccharolyticus* were developed by ALE to elevated glucose or acetate concentrations (Pawar 2014). In **Paper I**, several species of *Caldicellulosiruptor*, other than *C. saccharolyticus*, were adapted to elevated osmolarity by sequential batch cultivations with incrementally increasing glucose concentrations (Fig. 4). *C. owensensis* was successfully adapted to grow on 80 g/l glucose (*C. owensensis* CO80).

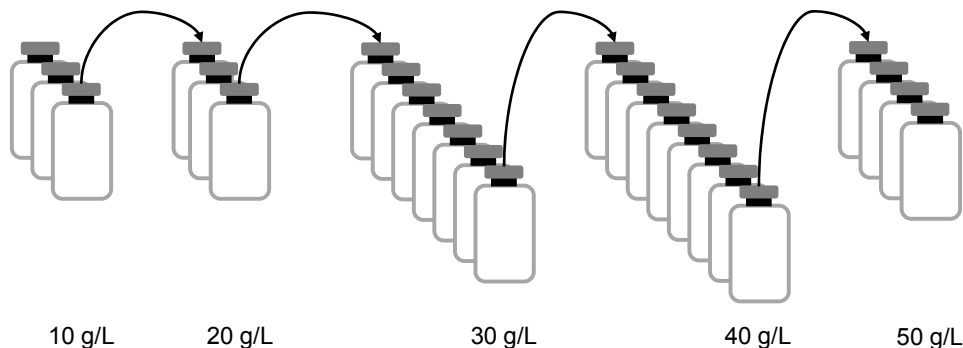

Figure 4 Illustration of subcultivations involved in the stepwise adaption of *Caldicellulosiruptor* species to higher osmolarity media

In **Paper I**, the species *C. acetigenus*, *C. bescii* and *C. kristjanssonii* were more resistant or possessed a limited ability to adaption to higher osmolarity. This was particularly true for *C. kristjanssonii*, where a loss of viability occurred in glucose concentrations as low as 20 g/l. The adapted strain *C. owensensis* CO80 demonstrated the ability to grow at glucose concentrations at 80 g/l. The model from **Paper I**, illustrates that at elevated osmolarities, the strain possessed increased critical osmolarities indicating that adaption had occurred. Although, *C. owensensis* was capable of growing at concentrations as high as 80 g/l glucose, the adapted strain had a significantly reduced Q_{H_2} at 80 g/l compared to observed values at 10 and 30 g/l glucose. In all cases, *C. owensensis* CO80 demonstrated a lower Q_{H_2} than the wild type strain. Additionally, when *C. owensensis* CO80 was cultivated on 30 g/l and 80 g/l glucose, incomplete substrate conversion occurred with significant cell lysis arising towards the end of each cultivation. This could indicate that although ALE resulted in the adaption of *C. owensensis*, this was at the expense of other attributes.

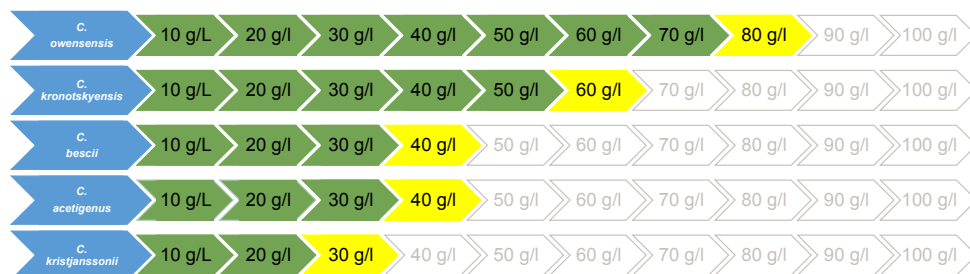

Figure 5 Development of osmotolerant strains of *Caldicellulosiruptor*. Values in green indicate osmotolerant adaption steps completed on stated concentrations of glucose. Values in yellow specify the highest glucose concentration that each species was adapted

Although, ALE is a promising technique for strain improvement, it experiences the limitations commonly associated with asexual evolution, namely, clonal interference and Muller's ratchet (Peabody et al. 2016). Clonal interference refers to the evolution of multiple strains with beneficial attributes when a large population number exists. When one strain develops a beneficial mutation, a relatively long period of time is required for this strain to become dominant in a large population. During this time other strains can develop different beneficial mutations. These evolved strains, can potentially compete with each other for dominance (Muller 1932). This competition could lead to the loss of potential beneficial phenotypes through a process known as the competitive exclusion principle whereby two organisms competing for a limited resource are unable to co-exist (Hardin 1960). Muller's ratchet on the other hand suggests that organisms are more likely to acquire and accumulate deleterious mutations when reproducing asexually eventually leading to a loss of fitness (Felsenstein 1974, Muller 1964). The effects of Muller's ratchet are generally observed in low population densities and can occur due to a bottleneck in population size, i.e. subcultivation with a limited quantity of organisms in the inoculum (De Visser & Rozen 2005, Poon & Otto 2000). In **Paper I**, ALE of *C. owensensis* involved the repeated subcultivation with a medium volume of 25 mL using a starting OD₆₂₀ of 0.02. This low initial inoculum concentration could have resulted in a loss of fitness due to the effects of Muller's ratchet.

4.2 Process improvement

4.2.1 Designed co-cultures

The Q_{H_2} of *Caldicellulosiruptor* cultivations can potentially be increased through utilisation of designed co-cultures. Unlike undefined cultures, such as those derived from anaerobic sludge, in defined co-cultures the identity of the organisms present in the cultivation are known (Chapter 2) and may also demonstrate superior performance to mono-cultures (Zeidan & van Niel, 2009). When *C. saccharolyticus* and *C. kristjanssonii* are cultivated together, a greater Q_{H_2} is obtained compared to when either species is cultivated in mono-culture, indicating that a synergistic effect exists (Zeidan & Van Niel 2009). However, the mechanism in which Q_{H_2} is increased by the co-cultivation of *Caldicellulosiruptor* species has yet to be identified. Furthermore, when *C. saccharolyticus* and *C. kristjanssonii* are cultivated in co-culture in a chemostat at varying dilution rates, both species remain in a stable population dynamic at each dilution rate, even in a medium containing one energy and carbon source (Zeidan et al. 2010). The latter appears to defy the competitive exclusion principle in which two species

competing for a limited resource cannot co-exist (Hardin 1960). Similarly, co-cultures of *C. saccharolyticus* and *C. owensensis* demonstrated that a lower quantity of lactate was formed compared to that of *C. owensensis* mono-cultures (Zeidan & Van Niel 2009). A higher Q_{H_2} occurs when *C. saccharolyticus* and *C. owensensis* were cultivated in each other's supernatants (Pawar et al. 2015). In **Papers II and III**, the osmotolerant strain *C. owensensis* CO80 developed in **Paper I** was cultivated in co-culture with the osmotolerant *C. saccharolyticus* G5 developed by Pawar (2014). However, differing from the aforementioned instances, the co-culture of *C. owensensis* CO80 and *C. saccharolyticus* G5 resulted in a predominantly *C. saccharolyticus* G5 population with only a minute population of *C. owensensis* CO80 being present (**Paper I**). However, significant biofilm was formed.

In nature, consortia of microorganisms are capable of nutrient cycling whereby one organism produces a nutrient that another organism can utilise (Paerl & Pinckney 1996). This principle can also be applied when undertaking designed co-cultures (Zuroff & Curtis 2012). This was previously demonstrated by the cultivation of the cellulolytic *Clostridium thermocellum* and the non-cellulolytic *Clostridium thermopalmarium* in co-culture using cellulose as a substrate. In this case, the cellulolytic activity of *Clostridium thermocellum* provided soluble sugars to the non-cellulolytic bacterium permitting for a two-fold increase in Q_{H_2} compared to mono-cultures (Geng et al., 2010). In **Paper V**, a designed co-culture of *C. saccharolyticus* and the proteolytic bacterium *Coprothermobacter proteolyticus* was investigated to determine if Q_{H_2} could be improved by the addition of *Co. proteolyticus*, facilitating the co-consumption of glucose and proteins while yielding ammonia that could be directly used by *C. saccharolyticus* as a nitrogen source (Fig. 6). The co-culture with *C. saccharolyticus* and *Co. proteolyticus* without the addition of NH_4Cl possessed a significantly higher Q_{H_2} than *Co. proteolyticus* mono-cultures while Q_{H_2} was similar to that of *C. saccharolyticus* cultivated with peptone. This demonstrates that *Co. proteolyticus* can potentially provide a nitrogen source from the degradation of proteins. This would be beneficial when hydrolysates with high protein content are fermented, i.e. lucerne hydrolysate (**Paper II**). However, as *Co. proteolyticus* grows poorly at 70°C (Ollivier et al. 1985), a temperature of 60°C was selected. The cultivation of *C. saccharolyticus* at 60°C resulted in a dramatic reduction in Q_{H_2} and increased lactate formation, likely due to the effects of hydrogenase inhibition (see 3.3.1). This could be potentially overcome by cultivation at an elevated temperature closer to the optimum range of *C. saccharolyticus*.

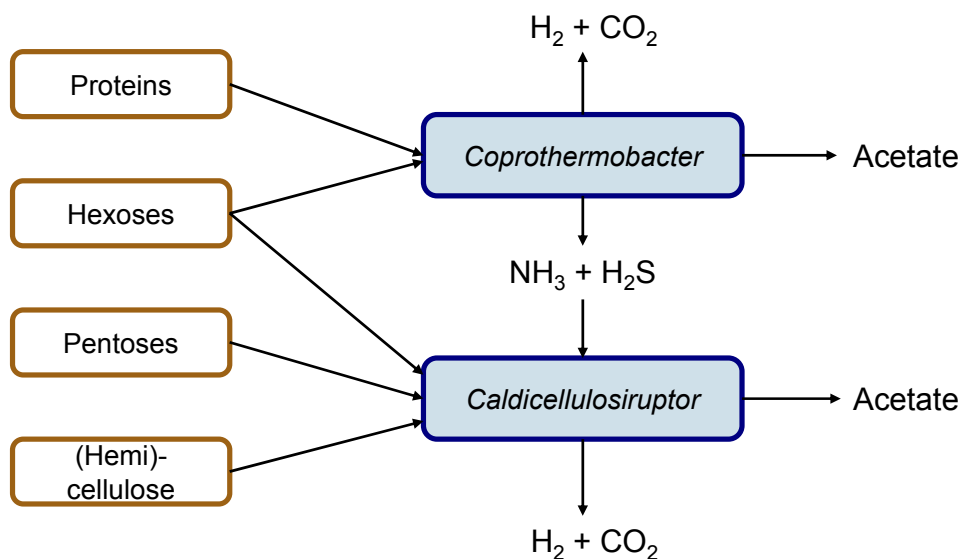

Figure 6 Nutrient recycling during a *Caldicellulosiruptor* and *Coprothermobacter* co-cultivation

4.2.2 Biofilm

As previously stated in Chapter 3, low biomass quantities during the cultivation of *Caldicellulosiruptor* directly leads to low Q_{H_2} . The formation of biofilm has been demonstrated to increase the productivity of a number of industrial processes by enabling cell mass retention and therefore a greater cell density (Qureshi et al. 2005, Van Loosdrecht & Heijnen 1993). Biofilm formation has been established to be advantageous to hydrogen fermentation by enhancing Q_{H_2} due to cell mass retention (Pawar et al. 2015, van Groenestijn et al. 2002, Zhang et al. 2008). Biofilm formation can be promoted in a *Caldicellulosiruptor* process by the addition of *C. owensensis* due to its ability to generate large quantities of biofilm (Pawar et al. 2015, Peintner et al. 2010). This is illustrated by the high Q_{H_2} (20 mmol/L/h) achieved when *C. saccharolyticus* and *C. owensensis* were cultivated in a co-culture (Fig. 7) using an upflow anaerobic reactor (Pawar et al. 2015).

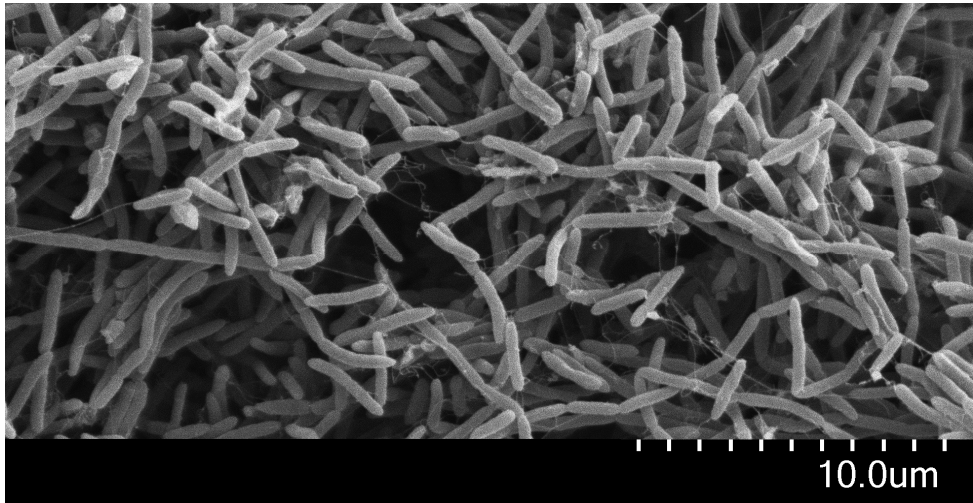

Figure 7 Scanning electron micrograph of a co-culture of *C. saccharolyticus* and *C. owensensis* wild types. Image provided with permission by Sudhanshu Pawar

In **Paper II**, co-cultures of the osmotolerant strains *C. saccharolyticus* G5 and *C. owensensis* CO80 were conducted to generate hydrogen from wheat straw hydrolysate and a blend of wheat straw and lucerne hydrolysates. As stated in **Paper I**, *C. saccharolyticus* G5 was dominant in these co-cultures. Nevertheless, a significant quantity of biofilm was formed during each co-culture indicating that *C. owensensis* CO80 may have been present in higher population numbers but localised to the biofilm (Fig. 8).



Figure 8 Biofilm formation during co-cultivation of *C. saccharolyticus* G5 and *C. owensensis* CO80 cultivated on wheat straw hydrolysate

4.2.3 Substrate optimisation

As discussed in chapter 3, a central monetary cost of an industrial process involving *Caldicellulosiruptor* is the necessity to supplement fermentation processes with compounds required for growth but not available directly from lignocellulose. A process model of *C. saccharolyticus* cultivations illustrated that significant expenditure would be incurred through the addition of buffers to maintain pH and nutrients such as yeast extract (Ljunggren & Zacchi 2010a). It has also been established that yeast extract and amino acids can be substituted with a vitamin solution (Willquist & van Niel 2012). As such, yeast extract was omitted from *Caldicellulosiruptor* cultivations in **Papers I, II, III, IV and V**.

In **Paper II**, a new trace metal medium was developed based on the metal composition of the biomass of *C. saccharolyticus* and was trialled using both defined media and hydrolysates. The total concentration of phosphate in this medium was decreased by 90% compared to the previously described modified DSM 640 medium (Willquist & van Niel 2012). In addition to the higher process costs resulting from phosphate addition due to the addition of phosphate buffers, the utilisation of phosphorus itself is not environmentally sustainable as it is mined from a finite source, already heavily relied upon for agricultural purposes (Dawson & Hilton 2011, Ljunggren & Zacchi 2010a). However, a reduction in Q_{H_2} was observed when EB-1 solution was employed compared to the modified DSM 640 indicating that further nutrient optimisation is required.

As previously stated, yeast extract can be omitted from *Caldicellulosiruptor* cultivations, albeit requiring substitution with a vitamin solution (Willquist & van Niel 2012). The current vitamin solution (with the exception of cobalamin) used in **Papers I, II, III, IV and V** is based on a non-optimised vitamin solution (Wolin et al. 1963). The *Caldicellulosiruptor* genus was previously stated to contain most of the metabolic pathways needed for vitamin synthesis with the exception of cobalamin (vitamin B12) pathways (Kridelbaugh et al. 2013, Willquist & van Niel 2012). In **Paper V**, the cultivation of *C. saccharolyticus* with a cobalamin only vitamin solution resulted in cell wash out during continuous culture, indicating that in addition to cobalamin, at least one other vitamin is required. A further bioinformatic study indicated that incomplete metabolic pathways exist for folate, biotin and riboflavin synthesis (**Paper V**).

As a sulphur source, cysteine can be replaced with sulphate for all *Caldicellulosiruptor* species except *C. owensensis*, *C. obsidiansis* and *C. lactoaceticus* which lack the sulphate assimilation pathway (Pawar & van Niel 2014). Therefore throughout these studies cysteine continued to be supplemented.

Interestingly, the absence of yeast extract resulted in a noticeable biphasic Q_{H_2} during batch fermentation of *C. saccharolyticus* on sugar mixtures in **Paper IV**, with a more pronounced effect when wheat straw hydrolysate was employed. This biphasic Q_{H_2} behaviour has not been previously reported in studies that cultivated

C. saccharolyticus on mixed sugars or hydrolysates, however in these instances yeast extract was also supplemented (de Vrije et al. 2009, de Vrije et al. 2010, Pawar et al. 2015, VanFossen et al. 2009).

4.2.4 Process coupling

The biorefinery concept relies on the generation of a diverse range of higher value products from the lignocellulose substrate (see Chapter 1). During the cultivation of *Caldicellulosiruptor*, in addition to hydrogen, in optimum conditions the major by-product is acetate. At a Y_{H_2} of 4 mol H_2 /mol hexose, a maximum of 33% of electrons are used for hydrogen synthesis while the remaining electrons are contained within the acetate by-product. This acetate can be further fermented into additional products using sequential fermentation processes with a multiple reactor set-up. Acetate derived from dark fermentation has been studied in detail in attempts to further hydrogen evolution via coupled photofermentation (Argun & Kargi 2011, Tao et al. 2007, Özgür et al. 2010b).

Alternatively, the acetate produced during dark fermentation can be used to yield methane. In the process of methanogenesis, acetate or CO_2 and H_2 can be biologically converted to methane by methanogenic archaea (Ferry 1992, Zeikus 1977). Several studies have involved the addition of *Caldicellulosiruptor* to methanogenic consortia to enhance methane production (Bagi et al. 2007, Nielsen et al. 2007). The independent production of hydrogen and methane can be obtained by the implementation of a two-step process where initially a dark fermentation process yields hydrogen and acetate, whereas the second step relies on the conversion of acetate to methane by anaerobic digestion (Benemann 1998, Cooney et al. 2007, Willquist et al. 2012).

As stated in Chapter 3, the inability of *Caldicellulosiruptor* to grow in high substrate concentrations may lead to difficulty in downstream methanogenesis in a two-step process (Ljunggren et al. 2011b, Ljunggren & Zacchi 2010a). In **Paper II**, osmotolerant strains of *C. saccharolyticus* and *C. owensensis* were employed in a two-step dark fermentation and anaerobic digestion of wheat straw hydrolysate yielding both hydrogen and methane. The application of osmotolerant strains facilitated the utilisation of a 30% wheat straw hydrolysate solution, whereas wild-type *C. saccharolyticus* is incapable of growth on 20% wheat straw hydrolysate (Pawar et al. 2013). Similar yields of hydrogen and acetate were observed with the fermentation of wheat straw hydrolysate and the wheat straw/lucerne hydrolysate mixture. However, in both cases the Y_{H_2} was below 2 mol H_2 /mol hexose, likely due to the presence of lignin based inhibitors. Conversely, the Q_{H_2} of the fermentation of wheat straw hydrolysate by *C. saccharolyticus* exceeded that of the defined medium (**Paper I**), confirming a similar observation by Pawar et al. (2013). The effluent from dark fermentation of wheat straw and the hydrolysate

mixtures was further utilised to yield methane via anaerobic digestion with a methanogenic consortium. The anaerobic digestion of both hydrolysates resulted in a 75% yield of methane (theoretical yield of methane from COD) and a total COD reduction of 89%. The analysis of effluent of the methanogenic process established that almost total consumption of acetate produced by the *Caldicellulosiruptor* co-culture occurred during anaerobic digestion. Although, the application of osmotolerant strains of *Caldicellulosiruptor* displayed reduced Y_{H_2} and Q_{H_2} compared to wild type *C. saccharolyticus*, more concentrated hydrolysates could be used for the co-production of hydrogen and methane.

This acetate can also be further utilised to produce the bioplastic PHB. Acetate has been previously demonstrated to be a potential substrate for PHB production (Shirai et al. 1997, Wang & Yu 2001). In **Paper III**, acetate containing effluent from *Caldicellulosiruptor* fermentation of wheat straw hydrolysate was further converted by *Ralstonia eutropha* (*Cupriavidus necator*) to yield PHB. *R. eutropha* is unable to directly utilise xylose; however, as xylose had been preferentially metabolised by the *Caldicellulosiruptor* co-culture both residual glucose and acetate were present. The *Caldicellulosiruptor* fermentation increased the amount of substrate available to *R. eutropha* as a majority of acetate arose from xylose fermentation. Nevertheless, throughout the combined hydrogen and PHB fermentation processes, approximately 30% of glucose and 85% of acetate remained unused. Therefore further optimisation of this process is required to increase carbon utilisation.

5. Future development of the *Caldicellulosiruptor* process

In Chapter 4, techniques to enhance the *Caldicellulosiruptor* hydrogen production process were discussed. Although, these approaches did permit the generation of osmotolerant strains (**Paper I**), the integration of *Caldicellulosiruptor* into a multi-product system (**Paper II and III**) and reduction of phosphate and other nutrients in the culture medium (**Papers II and V**), the primary barriers of *Caldicellulosiruptor*, such as low Q_{H_2} , continue to restrict the applicability of this genus into a biorefinery system. Therefore continued research is needed to progress *Caldicellulosiruptor* to a point of industrial relevance. In this chapter the potential future approaches that could be undertaken to further enhance hydrogen production via *Caldicellulosiruptor* are presented.

5.1 Process design

Although, advancement towards biorefinery have been undertaken, there is still great capacity for further development and improvement of the *Caldicellulosiruptor* hydrogen process. Further investigation into processes such as biomass pretreatment, fermentation, process coupling and nutrient addition could potentially lead to increased Q_{H_2} and reduction of process costs.

5.1.1 Consolidated bioprocess

A consolidated bioprocess (CBP) is a single step-process where lignocellulosic biomass is simultaneously degraded and fermented within a single bioreactor. Unlike separate hydrolysis and fermentation (SHF), where separate enzymatic production, hydrolysis and fermentation of the lignocellulose material are required (**Paper II**), CBP relies on the fermenting organism to directly degrade lignocellulose by the production of cellulases (or hemicellulases), fermentation of hexoses and pentoses and yielding of product within a single process step (Fig. 9) (Lynd et al. 1996). A primary advantage of CBP is the reduced financial cost

associated with the production and addition of enzymes required for cellulose and hemicellulose degradation (Parisutham et al. 2014).

Caldicellulosiruptor is a promising candidate for integration into a CBP, given that numerous members of this genus are capable of degradation of both cellulose and hemicellulose via a host of glycoside hydrolases, unique tāpirins proteins for cellulose adhesion, along with the ability to co-metabolise hexoses and pentoses (Blumer-Schuette et al. 2015, Blumer-Schuette et al. 2010, VanFossen et al. 2009). This is exemplified by the capacity of *C. bescii* to solubilise and directly ferment unpretreated switchgrass with substrate concentration as high as 200 g/l, i.e., almost three-fold higher than discussed in **Paper I**. This CBP displayed less substrate inhibition compared to pretreated switchgrass through a SHF process, likely due to a lower osmolarity with non-pretreated biomass as most sugars were present in polymeric form. Additionally, the presence of lignin based inhibitors were mitigated as acid hydrolysis was substituted for CBP (Basen et al. 2014). It must be noted that the fermentation time required for CBP is considerably longer than that of hydrolysates. With *C. bescii*, the maximum solubilisation of poplar cellulose and hemicellulose required 10 days with hydrogen production continuing for 20 days (Yang et al. 2009). Product inhibition due to the formation of acetate during CBP arose with *C. bescii*, at concentrations of between 150 and 200 mM similar to those previously described for *C. saccharolyticus* (Basen et al. 2014, van Niel et al. 2003). Despite the higher reaction time required for CBP, a reduction of capital and operational expenditure could be as high as 50% compared to that of SHF as both pretreatment and enzyme production are avoided (Olson et al. 2012, Talluri et al. 2013). Future studies of CBP could focus on the use of *C. kronotskyensis* as it possesses the greatest array of glycoside hydrolases in the *Caldicellulosiruptor* genus (Blumer-Schuette et al. 2010). In addition, designed co-cultures of *Caldicellulosiruptor* could also be studied due to the potential for synergistic enhancement of Q_{H2}.

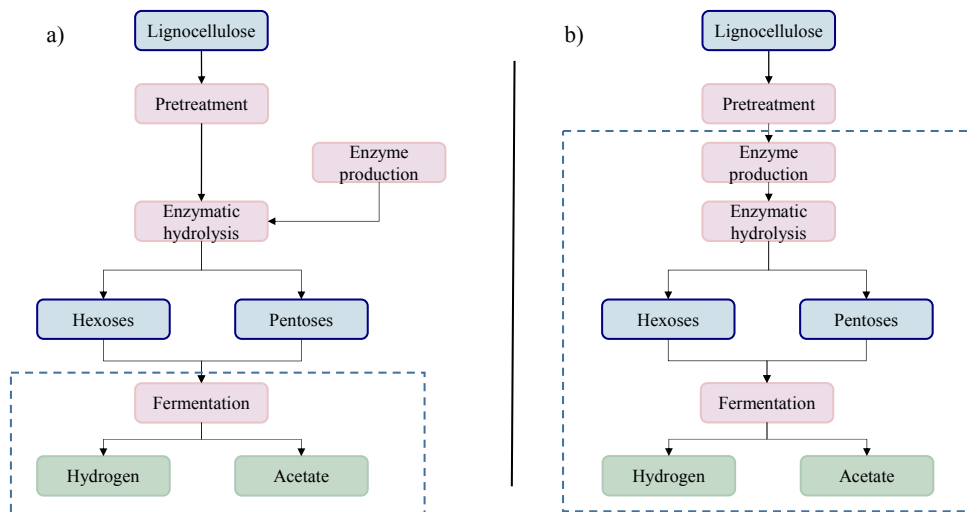

Figure 9 Illustration of a separate hydrolysis and fermentation (a) and consolidated bioprocessing (b) involving *Caldicellulosiruptor*. The dotted box indicates the processes and materials within a bioreactor. Compounds are denoted by blue colouration, processes are depicted in red and fermentation products are green. Adapted from Parisutham et al. (2014)

5.1.2 Fermentation processes

The optimisation of Q_{H_2} is an essential element of future development of processes involving *Caldicellulosiruptor* fermentation. Currently, a vast number of studies focusing on hydrogen production from *Caldicellulosiruptor* have relied on cultivations in continuous stirred tank reactors (CSTR). CSTRs are particularly susceptible to the supersaturation of hydrogen within the liquid phase as particularly high concentrations of hydrogen accumulate close to the liquid-gas interface (Ding et al. 2010, Kraemer & Bagley 2006). During the operation of a fermentation in a continuous configuration for hydrogen production, a balance must be made between Q_{H_2} , substrate conversion and dilution rate (Ljunggren & Zacchi 2010a). It is recommended that to enhance Q_{H_2} , a dilution rate of 0.1 h^{-1} or greater (hydraulic retention time of 10 h or less) should be employed (Martinez-Porqueras et al. 2013). However, it must be recognised that fermentations conducted at elevated dilution rates will increase the rate of cell washout (Wang & Wan 2009). When *C. saccharolyticus* was cultivated in chemostat with 4.2 g/l glucose, the highest cell density was observed at a dilution rate of 0.1 h^{-1} , whereas the highest Q_{H_2} occurred at a dilution rate of 0.35 h^{-1} . A drawback of operating at this higher dilution rate is that greater quantities of glucose remain in the effluent, demonstrating incomplete substrate conversion (de Vrije et al. 2007). Cell wash out can be averted by the implementation of a reactor system that permits recycling of cell mass (Holst et al. 1997, Martinez-Porqueras et al. 2013). One such system

implemented with a mesophilic hydrogen producing consortium involved modifying a CSTR in a continuous mode to include cell mass retention by employing a microfiltration system for the reactor effluent. This resulted in a significant improvement in Q_{H_2} , particularly at lower dilution rates (Bakonyi et al. 2015).

As illustrated in Table 5, the highest Q_{H_2} by *Caldicellulosiruptor* have been reported when alternative reactor systems are used other than a CSTR. Reactor designs that facilitate high Q_{H_2} broadly depend on increasing the liquid gas surface area, thereby increasing the mass transfer rate and avoiding hydrogen supersaturation. In addition, reactor design that facilitate biofilm formation within the bioreactor results in cell mass retention and further increases Q_{H_2} . The operation of a horizontal rotating cylinder reactor gave rise to higher Q_{H_2} with the mesophilic hydrogen producer *Clostridium butyricum*. This improvement in Q_{H_2} was due to the combination of an increase in the liquid-gas surface area generated by continuous rotation and the facilitation of biofilm production (Beckers et al. 2012). Q_{H_2} of an undefined hydrogen producing consortium can be enhanced by up to a factor of twenty with the implementation of an anaerobic fluidised bed reactor in comparison to a CSTR system, primarily through enhanced granule and biofilm formation (Zhang et al. 2008). A combined cultivation of *C. saccharolyticus* and *C. owensensis*, in an upflow anaerobic reactor produced a Q_{H_2} of over 20 mmol/L/h. This high Q_{H_2} was facilitated by cell mass retention due to biofilm formation by *C. owensensis* and the addition of a sterilised granular sludge matrix for biofilm adhesion. This reactor configuration could be operated at a very high dilution rate (1.25 h^{-1}), well beyond the critical dilution rate (Pawar et al. 2015). Further study is required into hydrogen production by *Caldicellulosiruptor* with alternative reactor configurations. The developed osmotolerant strains of *C. saccharolyticus* G5 and *C. owensensis* CO80 could be implemented into alternative reactors allowing more concentrated hydrolysates to be utilised (**Paper I**, Pawar 2014). In particular *C. owensensis* CO80 could potentially be used for biofilm formation and hence cell mass retention in systems with high substrate concentrations. Additionally further study is required into mechanisms to promote biofilm formation by particular *C. owensensis*.

Table 5 Production of hydrogen by *Caldicellulosiruptor* in various reactor configurations

Organism	Substrate (g/l)*	Reactor Type	Fermentation mode	Hydrogen productivity (mmol/L/h)**	Hydrogen yield mol/mol hexose	Reference
<i>C. saccharolyticus</i> <i>C. kristjanssonii</i>	G: 5 g/l X: 5 g/l	CSTR	Continuous	3.8 – 11.6	2.5 – 3.7	Zeidan et al. (2010)
<i>C. saccharolyticus</i>	G: 4.4 g/l	CSTR	Continuous	2.4 – 12.4	2.9 - 3.6	de Vrije et al. (2007)
<i>C. saccharolyticus</i>	G: 8.7g/l X: 3.4 g/l A: 0.4 g/l	CSTR	Batch	13.7	3.2	Paper IV
<i>C. saccharolyticus</i>	<i>Miscanthus</i> hydrolysate	CSTR	Batch	6.2 – 12.2	2.4 – 3.4	de Vrije et al. (2009)
<i>C. saccharolyticus</i>	Potato stem peels	CSTR	Batch	5.5 – 16.0	1.7 – 3.4	Mars et al. (2010)
<i>C. owensensis</i>	G: 10 g/l or X: 10 g/l	CSTR	Batch	9- 19	3.5 – 4.0	Zeidan and van Niel (2010)
<i>C. saccharolyticus</i> <i>C. owensensis</i>	G: 10 g/l	UA	Continuous	20	2.0 – 3.3	Pawar et al. (2015)
<i>C. saccharolyticus</i>	G: 2.7 g/l - 5.4 g/l	Trickle bed reactor	Continuous	22	2.8	van Groenestijn et al. (2009)

* Glucose, G; Xylose, X; Arabinose, A.

** Q_{H_2} during batch cultivation is denoted by the maximum value attained throughout cultivation

In addition, further enhancement of a two-step process involving *Caldicellulosiruptor* could be investigated by recycling of effluent from the second reactor to the dark fermentation reactor to function as a diluent. Such recycling has been modelled to permit a significant saving in both water (up to 90%) and the energy requirements for heating in a coupled dark and photofermentation process (Foglia et al. 2010). A recycling system can enhance a process by facilitating the retention of nutrients within the system particularly at high organic loading rates (Aslanzadeh et al. 2013). This type of effluent recycling could be implemented into two-step processes, illustrated in **Papers II and III**. As osmotolerant strains were utilised in both studies, further concentration of hydrolysates could be explored. Further studies are required concerning whether the recirculation itself would affect the overall osmolarity of the system and if the accumulation of inhibitory compounds would affect overall efficiency. As the implementation of a recycling system with osmotolerant strains would permit the use of even more concentrated hydrolysates, a significant reduction in operating costs could be achieved (Foglia et al. 2010, Ljunggren & Zacchi 2010a).

5.1.3 Additional products

The acetate product of *Caldicellulosiruptor* fermentation can be further fermented to generate additional products such as methane and PHB, as illustrated in **Papers II and III**. This acetate production platform can be expanded to yield additional compounds relevant for biorefinery purposes. One potential avenue of future research could focus on the production of lipids through a two-step process. Several species of fungi including *Mortierella isabellina* and *Cryptococcus curvatus* have been confirmed to accumulate high quantity of lipids when co-utilising glucose and acetate (Gong et al. 2016, Ruan et al. 2013). This type of lipid producing system could be coupled with a *Caldicellulosiruptor* fermentation in a two-step process, permitting the simultaneous formation of hydrogen and lipids. Such a system would be compatible with *Caldicellulosiruptor* as acetate and glucose are both present in effluent from wheat straw hydrolysate (**Paper II**). Furthermore, since *C. saccharolyticus* preferably converts xylose (**Paper IV**) a sizeable glucose residue remains and therefore the hydrogen reactor can be operated to produce an effluent rich in glucose and acetate. Another product that can be produced from acetate is caproate (Steinbusch et al. 2011). Caproate is of interest to biorefinery due to its potential use as a precursor for high value products in chemical synthesis (Chen et al. 2017). Organisms such as *Clostridium kluyveri* can produce caproate by fermenting a mixture of acetate and ethanol (Barker et al. 1945). In terms of biorefinery, ethanol could be derived from a parallel ethanol producing process or could be generated through a co-culture of *Caldicellulosiruptor* with a high yielding thermophilic ethanol producer such as *Thermoanaerobacter* J1 (Jessen & Orlygsson 2012).

Additional products could be generated by a two-step cultivation process with *Caldicellulosiruptor* based on its sugar utilisation pattern as *Caldicellulosiruptor* shows a general preference for pentoses over hexoses (VanFossen et al. 2009). In **Paper IV**, it was demonstrated that during *C. saccharolyticus* fermentation on mixed sugars, xylose depletion in a batch cultivation occurs before glucose is consumed at its optimal uptake rate. The fermentation of hydrolysates described in **Paper II**, demonstrated that a large proportion of xylose was utilised by the *Caldicellulosiruptor* co-culture while a significant quantity of glucose remained. This residual glucose could be used as a carbon source to yield an array of additional products, thereby permitting production of hydrogen from xylose and additional products from glucose. A two-step process involving independent glucose and xylose utilisation was illustrated by sequential inoculation of *Zymomonas mobilis* and *Pachysolen tannophilus* on mixed sugars to yield ethanol (Fu & Peiris 2008). Alternatively, a three-step reactor system could be designed, in the initial fermentation glucose would be consumed, followed by a xylose fermentation with, followed by a xylose fermentation with *Caldicellulosiruptor*

yielding hydrogen and acetate and finally an acetate utilisation fermentation (such as methane or PHB).

5.1.4 Media optimisation

In **Paper II**, a new trace element solution was determined based upon the composition of the biomass of *C. saccharolyticus*, however the implementation of this novel trace element solution resulted in lower Q_{H_2} . Further evaluation of the trace element solution is required to determine the optimum concentrations of each compound to ensure that excess nutrients are not added while also preventing a reduction in Q_{H_2} by nutrient limitations. Essentially, studies are required to ensure that quantities of micronutrients used in a modified trace element solution do not reach inhibitory concentrations. Additionally, further investigation into the vitamin requirements of *Caldicellulosiruptor* is required with respect to the addition of folate, biotin and riboflavin, and if the elimination or reduction of vitamin quantities has an effect on Q_{H_2} .

One of the most expensive compounds used in *Caldicellulosiruptor* cultivations is cysteine. The function of cysteine is to act as a reducing agent and as the sulphur source in *Caldicellulosiruptor* fermentation processes (Pawar & van Niel 2014). However, in most cases cysteine can be substituted with either sulphate or yeast extract as a sulphur source with the exception of several *Caldicellulosiruptor* species, notably *C. owensensis* that lacks the sulphate assimilation pathway (Bredholt et al. 1999, Pawar & van Niel 2014). Further studies could focus on the survival of *C. owensensis* in a co-culture environment during cysteine depletion.

5.2 Strain development

In **Paper I**, several species of *Caldicellulosiruptor* were adapted to survive in high osmolarity conditions through an ALE process. Further strain improvement can be achieved by continued adaption or molecular engineering.

5.2.1 Adaptive laboratory evolution

Although, the developed osmotolerant strain *C. owensensis* CO80 was capable of growth on more concentrated glucose solutions, a reduction in Q_{H_2} was observed at elevated osmolarities (**Paper I**). Further improvement of this strain could be accomplished through ALE by a more prolonged adaption to elevated osmolarities. An alternative strategy to that investigated in **Paper I**, is to apply the principles of ALE to continuous cultivation as the population with the most appropriate fitness

will remain in the system. Moreover, additional ALE strategies could be implemented that enable production of strains with beneficial properties. A promising avenue of investigation could involve direct adaption of *Caldicellulosiruptor* to the lignocellulosic hydrolysates as was illustrated by adaption of *Clostridium tyrobutyricum* to higher concentrations of wheat straw hydrolysate (Baroi et al. 2015). *Caldicellulosiruptor* could be adapted via ALE to tolerate inhibitors commonly found within hydrolysates, similar to the approach taken to adapt the ethanol-producing bacterium *Zymomonas mobilis*, to elevated furfural and acetate concentrations (Shui et al. 2015). As noted previously, in CBP inhibition occurs due to the formation of acetate during *Caldicellulosiruptor* fermentation. To overcome this hindrance, *Caldicellulosiruptor* species can be adapted through ALE to tolerate higher acetate concentrations, which has been previously demonstrated with *C. saccharolyticus* (Pawar 2014). Further ALE of strains developed in **Paper I** could permit additional adaption to higher concentrations of hydrolysates and inhibitors.

5.2.2 Genetic methods

Metabolic engineering of *Caldicellulosiruptor* has been previously hindered by a general lack of genetic tools for thermophilic organisms. Within the *Caldicellulosiruptor* genus only two species, *C. bescii* and *C. hydrothermalis*, have been engineered (Chung et al. 2013a, Chung et al. 2012).

One of the main difficulties with the development of genetic methods for *Caldicellulosiruptor* is the restriction-modification system, where non-methylated DNA is degraded by endogenous restriction enzymes (Chung et al. 2012, Pawar 2014). All studied *Caldicellulosiruptor* species possess a minimum of three different restriction-modification systems (Chung et al. 2013b). In addition, only *C. bescii* and *C. kristjanssonii* are known to possess native plasmids (Blumer-Schuette et al. 2011, Clausen et al. 2004). Further advances in engineering of other *Caldicellulosiruptor* species could involve a similar approach as previously described, whereby endogenous methylases are expressed in *E. coli*, purified and used to methylate plasmids to be transformed into a *Caldicellulosiruptor* species (Chung et al. 2012). After this initial process is designed, the deletion of restriction enzymes within the genome as was previously undertaken *C. bescii*, thereby removing the restriction-modification barriers for future engineering (Chung et al. 2013b). This approach has also been attempted with *C. saccharolyticus* (results not shown), however the *C. saccharolyticus* methylases expressed in *E. coli* did not demonstrate any functionality and were unable to methylate plasmids. Significant research is required to allude the methylation systems, clone and produce endogenous methylases to undertake in vivo methylation and demonstrate if

existing plasmids present in the *Caldicellulosiruptor* genus are capable of replication in other members of the genus.

The metabolic engineering of *Caldicellulosiruptor* could be implemented to enhance hydrogen production through numerous mechanisms, such as the expression of additional glycoside hydrolases to enhance lignocellulose degradation and alteration of sugar uptake by ABC transporters. In addition, genomic sequencing of osmotolerant strains developed in **Paper I**, could discern the osmotolerant mechanism in *Caldicellulosiruptor* and be used to enhance other strains through metabolic engineering. Furthermore, the application of genetic methods can permit the understanding of the metabolism of *Caldicellulosiruptor*. The prime example of this was that the deletion of the glycoside hydrolase CelA in *C. bescii*, revealed the essential role of this enzyme in cellulose degradation (Young et al. 2014).

5.3 Co-cultivation

Co-cultures of varying *Caldicellulosiruptor* species can enhance Q_{H_2} by synergistic effects and biofilm formation (Pawar et al. 2015, Zeidan & Van Niel 2009). The selection of additional organisms, both within and outside the *Caldicellulosiruptor* genus for co-cultures could permit improvement of hydrogen fermentation processes. One potential candidate for co-culture within the *Caldicellulosiruptor* genus is *C. kronotskyensis*. *C. kronotskyensis* is noted for possessing the most diverse range of glycoside hydrolases of the *Caldicellulosiruptor* genus and its ability to solubilise cellulose and lignocellulose. (Blumer-Schuette et al. 2010, Zurawski et al. 2015) Therefore, *C. kronotskyensis* would be particularly well suited for development of a *Caldicellulosiruptor* based CBP. Future studies should focus on the performance of *C. kronotskyensis* in co-culture with other members of the *Caldicellulosiruptor* genus.

The addition of *Co. proteolyticus* to a cultivation with a mixture of sugar and peptone, increased Y_{H_2} (**Paper V**) compared to a *C. saccharolyticus* mono-culture. One possibility would be to implement a co-culture of *Caldicellulosiruptor* species with *Co. proteolyticus* with lignocellulose hydrolysates or as part of a consolidated bioprocess. In the case of a consolidated bioprocess, a symbiotic relationship could be formed, whereby *Caldicellulosiruptor* degrades cellulose yielding glucose that in turn can be utilised by *Co. proteolyticus*. Complementary, *Co. proteolyticus* would degrade protein yielding ammonia that would be utilised by *Caldicellulosiruptor* as a nitrogen source. This approach could be used to degrade protein to provide cysteine as a sulphur source to *C. owensensis*, permitting the omission of cysteine from the culture medium. Future studies in this area would also need to be focused on temperature optimisation to ensure high Q_{H_2} .

An alternative approach to the addition of vitamins to *Caldicellulosiruptor* fermentation processes could rely on co-cultures where one member would produce the lacking vitamins. This was previously demonstrated in mesophilic cultures where co-cultivation of *Clostridium thermocellum*, lacking the ability to synthesise cobalamin, and *Thermoanaerobacter*, capable of de novo cobalamin synthesis, demonstrated higher ethanol productivity than in mono-culture, indicating that the synthesis of cobalamin by *Thermoanaerobacter* stimulated *Cl. thermocellum* (He et al., 2011). It was also revealed that although cobalamin was produced, it remained a limiting factor for *C. thermocellum*. Therefore, further studies are required in this area to optimise the process such as molecular engineering of *Thermoanaerobacter* to yield higher quantities of cobalamin, thereby meeting the vitamin requirement of *Cl. thermocellum*.

Future studies of *Caldicellulosiruptor* could focus on the use of designed mixed consortia that would allow for the generation of biofilm and nutrients, permitting higher Q_{H_2} through enhanced cell mass retention and a more efficient and cost-effective fermentation process. This could also be coupled with CBP to allow for an efficient system, whereby a limited amount of inexpensive input material, other than the lignocellulose, is added.

6. Conclusions

The main conclusions of this thesis are:

- The application of ALE permitted the adaptation of five *Caldicellulosiruptor* species to elevated osmolarities (**Paper I**)
- Strain improvement through ALE has various degrees of success for the improvement of *Caldicellulosiruptor* species with *C. owensensis* capable of adaption to 80 g/l glucose while *C. kristjanssonii* could only be adapted to 30 g/l (**Paper I**)
- The strain *C. owensensis* CO80 developed via ALE can grow in concentrations of 80 g/l glucose, albeit with reduced Q_{H_2} at elevated substrate concentrations (**Paper I**). Further research is needed to enable both high substrate concentrations and high Q_{H_2}
- Osmotolerant strains of *Caldicellulosiruptor* can produce hydrogen from more concentrated hydrolysates than wild type species (**Paper II**)
- The developed trace element solution EB-1 enables a phosphorus reduction of 90%, although this also results in a lower Q_{H_2} than the previous modified DSM640 medium (**Paper II**)
- Co-cultures of osmotolerant strains *C. owensensis* CO80 and *C. saccharolyticus* demonstrated that *C. saccharolyticus* was the dominant species in the co-culture, with only a low *C. owensensis* CO80 population remaining (**Paper I**), however, significant biofilm was observed indicating that *C. owensensis* CO80 may have been localised to the biofilm.
- The critical osmolarity of *C. owensensis* CO80 increases with higher osmolarity (**Paper I**)
- Maillard reactions at 70°C results in inhibition of *Caldicellulosiruptor* (**Paper I**)
- Cultivation of *Caldicellulosiruptor* on hydrolysates results in a higher Q_{H_2} than on defined medium (**Paper II**)
- Significant concentrations of glucose remain after continuous cultivation with hydrolysates while xylose is depleted (**Paper II**)
- *Caldicellulosiruptor* effluent can be further fermented into methane and PHB and coupled into a two-step process (**Papers II and III**)
- A coupled process with *Caldicellulosiruptor* and *Ralstonia eutropha* can allow the indirect utilisation of xylose by *R. eutropha* through the formation of acetate by *Caldicellulosiruptor*

- A diauxic pattern in hydrogen production is observed when *C. saccharolyticus* is cultivated on a sugar mixture (**Paper IV**)
- This diauxic-like effect is more pronounced with hydrolysate than artificial medium (**Paper IV**)
- Co-culture of *C. saccharolyticus* and *Co. proteolyticus* can potentially provide a nitrogen source to *C. saccharolyticus* through protein degradation by *Co. proteolyticus* (**Paper V**)
- A significant metabolic shift to lactate is observed by reduction of cultivation temperature from 70°C to 60°C, while Y_{H_2} is decreased to 1.75 mol H₂/ mol hexose (**Paper V**)
- Although Q_{H_2} did not significantly increase with the addition of *Coprothermobacter proteolyticus*, an increase in hydrogen yield was observed (**Paper V**)

Acknowledgements

Over the last four years, this PhD has been filled with a lot of hard work, learning and fun enjoyable times. I would like to take this opportunity to express my sincere gratitude to all the people who supported and offered me guidance throughout my PhD.

My main supervisor, Ed van Niel, I would like to thank you so much for giving me the amazing opportunity to carry out research in such an interesting area. Thank you for all the guidance, support and always finding the time to discuss both scientific and non-scientific subjects. Most of all, thank you for all the laughs over the years.

My co-supervisor, Karin Willquist, thank you for your scientific guidance and support throughout my PhD. Thank you for teaching me so much about research. I have really enjoyed the many interesting chats we've had together.

Thank you to the partners involved in this research, Emma Kreuger, Johanna Björkmalm, Luis Romero Soto, Krishnan Sreenivas, Krisztina Kovacs and Rajni Hatti-Kaul, for your dedication, hard work and for sharing your knowledge with me.

My master thesis supervisor, Sudhanshu, thank you so much for bringing me into TMB, introducing me and piquing my interest in "Caldi" and starting me on my PhD journey.

I would like to thank Anette for all your hard work with the administrative aspects of the research. Especially, thank you for your kindness and willingness to solve any problem.

My sincere thanks to Christer for all your help with any technical problems that arose and for your amazing ability to fix any piece of equipment, particularly the bane of my life, the HPLC.

I would also like to thank my students, Lisa, Anne-Laure, Khalid, Helga and James not only for your invaluable contribution to this research but for also creating a great atmosphere in the lab.

A special thanks to Thitiwut, for your friendship over the entirety of my master's degree and PhD. Thank you for the many interesting discussions and the help with the bioreactors in the lab

Thank you to Javier, Karen, Marie and Yasmine for all the great moments both in and outside TMB and for all the jokes and laughter, often (deservedly) at my expense.

Thank you to all the members of the lunch group, Alex, Diogo, Javier, João, Venkat, Yasmine and Yusak, for all the fun, laughter and the totally random conversations at IKDC.

My current and former office mates, Alex, Arne, Daniel, Catherine, Lisa and Malin, thank you for all the scientific and random discussions. Also, sorry to you all for my very untidy desk.

Thank you to Celina, Christer, Daniel and Kristjan for the great times teaching the lab courses.

Thanks to Jenny Schelin for the many interesting conversations at TMB during the evenings and weekends when I was working with the bioreactors.

Thank you Celina for all the interesting conversations and for always being willing to offer advice in the lab.

Thanks to Maja and Karen for all the important thesis writing discussions.

To all the current and former members of TMB, thank you for creating a great work environment and making my PhD an enjoyable experience. I will really miss the fikas.

My friends, Johnny, Sarah, Ann, Dawn and Chloe, back home in Ireland. Thank you so much for all the great times and the many years of friendship.

My sister, Cliona, thank you for your love, support and being the best sister ever. I promise I will go and visit you and Alastair soon in Paris.

Last but definitely not least, my parents, Joe and Niamh, thank you so much for your unwavering support, encouragement and love and for giving me so many opportunities throughout my life.

References

- Agbor, V.B., Cicek, N., Sparling, R., Berlin, A., Levin, D.B. 2011. Biomass pretreatment: Fundamentals toward application. *Biotechnology Advances*, **29**(6), 675-685.
- Ajanovic, A. 2011. Biofuels versus food production: Does biofuels production increase food prices? *Energy*, **36**(4), 2070-2076.
- Altın, R., Çetinkaya, S., Yücesu, H.S. 2001. The potential of using vegetable oil fuels as fuel for diesel engines. *Energy Conversion and Management*, **42**(5), 529-538.
- Argun, H., Kargi, F. 2011. Bio-hydrogen production by different operational modes of dark and photo-fermentation: An overview. *International Journal of Hydrogen Energy*, **36**(13), 7443-7459.
- Aro, E.-M. 2016. From first generation biofuels to advanced solar biofuels. *Ambio*, **45**(1), 24-31.
- Asada, Y., Miyake, J. 1999. Photobiological hydrogen production. *Journal of Bioscience and Bioengineering*, **88**(1), 1-6.
- Aslanzadeh, S., Rajendran, K., Jeihanipour, A., Taherzadeh, M.J. 2013. The Effect of Effluent Recirculation in a Semi-Continuous Two-Stage Anaerobic Digestion System. *Energies*, **6**(6), 2966.
- Associated Press. 1925. Ford predicts fuel from vegetation. in: *New York Times*, Vol. LXVII, New York Times. New York, pp. 24.
- Bagi, Z., Ács, N., Bálint, B., Horváth, L., Dobó, K., Perei, K.R., Rákhely, G., Kovács, K.L. 2007. Biotechnological intensification of biogas production. *Applied Microbiology and Biotechnology*, **76**(2), 473-482.
- Bakonyi, P., Nemestóthy, N., Lankó, J., Rivera, I., Buitrón, G., Bélafi-Bakó, K. 2015. Simultaneous biohydrogen production and purification in a double-membrane bioreactor system. *International Journal of Hydrogen Energy*, **40**(4), 1690-1697.
- Balat, M. 2008. Potential importance of hydrogen as a future solution to environmental and transportation problems. *International Journal of Hydrogen Energy*, **33**(15), 4013-4029.
- Balat, M., Balat, M. 2009. Political, economic and environmental impacts of biomass-based hydrogen. *International Journal of Hydrogen Energy*, **34**(9), 3589-3603.
- Bari, M.N., Alam, M.Z., Muyibi, S.A., Jamal, P., Abdullah Al, M. 2009. Improvement of production of citric acid from oil palm empty fruit bunches: Optimization of media by statistical experimental designs. *Bioresource Technology*, **100**(12), 3113-3120.
- Barker, H.A., Kamen, M.D., Bornstein, B.T. 1945. The synthesis of butyric and caproic acids from ethanol and acetic acid by *Clostridium kluyveri*. *Proceedings of the National Academy of Sciences of the United States of America*, **31**(12), 373-381.

- Baroi, G.N., Baumann, I., Westermann, P., Gavala, H.N. 2015. Butyric acid fermentation from pretreated and hydrolysed wheat straw by an adapted *Clostridium tyrobutyricum* strain. *Microbial Biotechnology*, **8**(5), 874-882.
- Basen, M., Rhaesa, A.M., Kataeva, I., Prybol, C.J., Scott, I.M., Poole, F.L., Adams, M.W.W. 2014. Degradation of high loads of crystalline cellulose and of untreated plant biomass by the thermophilic bacterium *Caldicellulosiruptor bescii*. *Bioresource Technology*, **152**, 384-392.
- Beckers, L., Hiligsmann, S., Masset, J., Hamilton, C., Thonart, P. 2012. Effects of Hydrogen Partial Pressure on Fermentative Biohydrogen Production by a Chemotropic *Clostridium Bacterium* in a New Horizontal Rotating Cylinder Reactor. *Energy Procedia*, **29**, 34-41.
- Beckers, L., Masset, J., Hamilton, C., Delvigne, F., Toye, D., Crine, M., Thonart, P., Hiligsmann, S. 2015. Investigation of the links between mass transfer conditions, dissolved hydrogen concentration and biohydrogen production by the pure strain *Clostridium butyricum* CWBI1009. *Biochemical Engineering Journal*, **98**, 18-28.
- Behera, S., Arora, R., Nandhagopal, N., Kumar, S. 2014. Importance of chemical pretreatment for bioconversion of lignocellulosic biomass. *Renewable and Sustainable Energy Reviews*, **36**, 91-106.
- Benemann, J. 1996. Hydrogen biotechnology: Progress and prospects. *Nature Biotechnology*, **14**, 1101.
- Benemann, J.R. 2000. Hydrogen production by microalgae. *Journal of Applied Phycology*, **12**(3), 291-300.
- Benemann, J.R. 1998. The Technology of Biohydrogen. in: *BioHydrogen*, (Eds.) O.R. Zaborsky, J.R. Benemann, T. Matsunaga, J. Miyake, A. San Pietro, Springer US. Boston, MA, pp. 19-30.
- Bergquist, P.L., Gibbs, M.D., Morris, D.D., Te'o, V.S.J., Saul, D.J., Morgan, H.W. 1999. Molecular diversity of thermophilic cellulolytic and hemicellulolytic bacteria. *FEMS Microbiology Ecology*, **28**(2), 99-110.
- Bielen, A.A.M., Verhaart, M.R.A., Oost, J., Kengen, S.V.M. 2013a. Biohydrogen production by the thermophilic bacterium *Caldicellulosiruptor saccharolyticus*: current status and perspectives. *Life*, **3**.
- Bielen, A.A.M., Verhaart, M.R.A., VanFossen, A.L., Blumer-Schuette, S.E., Stams, A.J.M., van der Oost, J., Kelly, R.M., Kengen, S.W.M. 2013b. A thermophile under pressure: Transcriptional analysis of the response of *Caldicellulosiruptor saccharolyticus* to different H₂ partial pressures. *International Journal of Hydrogen Energy*, **38**(4), 1837-1849.
- Bing, W., Wang, H., Zheng, B., Zhang, F., Zhu, G., Feng, Y., Zhang, Z. 2015. *Caldicellulosiruptor changbaiensis* sp. nov., a cellulolytic and hydrogen-producing bacterium from a hot spring. *International Journal of Systematic and Evolutionary Microbiology*, **65**(1), 293-297.
- Blumer-Schuette, S.E., Alahuhta, M., Conway, J.M., Lee, L.L., Zurawski, J.V., Giannone, R.J., Hettich, R.L., Lunin, V.V., Himmel, M.E., Kelly, R.M. 2015. Discrete and structurally unique proteins (tāpirins) mediate attachment of extremely thermophilic *Caldicellulosiruptor* species to cellulose. *Journal of Biological Chemistry*.

- Blumer-Schuette, S.E., Kataeva, I., Westpheling, J., Adams, M.W.W., Kelly, R.M. 2008. Extremely thermophilic microorganisms for biomass conversion: status and prospects. *Current Opinion in Biotechnology*, **19**(3), 210-217.
- Blumer-Schuette, S.E., Lewis, D.L., Kelly, R.M. 2010. Phylogenetic, Microbiological, and Glycoside Hydrolase Diversities within the Extremely Thermophilic, Plant Biomass-Degrading Genus *Caldicellulosiruptor*. *Applied and Environmental Microbiology*, **76**(24), 8084-8092.
- Blumer-Schuette, S.E., Ozdemir, I., Mistry, D., Lucas, S., Lapidus, A., Cheng, J.-F., Goodwin, L.A., Pitluck, S., Land, M.L., Hauser, L.J., Woyke, T., Mikhailova, N., Pati, A., Kyrpides, N.C., Ivanova, N., Detter, J.C., Walston-Davenport, K., Han, S., Adams, M.W.W., Kelly, R.M. 2011. Complete Genome Sequences for the Anaerobic, Extremely Thermophilic Plant Biomass-Degrading Bacteria *Caldicellulosiruptor hydrothermalis*, *Caldicellulosiruptor kristjanssonii*, *Caldicellulosiruptor kronotskyensis*, *Caldicellulosiruptor owensensis*, and *Caldicellulosiruptor lactoaceticus*. *Journal of Bacteriology*, **193**(6), 1483-1484.
- Bozell, J.J., Petersen, G.R. 2010. Technology development for the production of biobased products from biorefinery carbohydrates—the US Department of Energy’s “Top 10” revisited. *Green Chemistry*, **12**(4), 539-554.
- Bredholt, S., Sonne-Hansen, J., Nielsen, P., Mathrani, I.M., Ahring, B.K. 1999. *Caldicellulosiruptor kristjanssonii* sp. nov., a cellulolytic, extremely thermophilic, anaerobic bacterium. *International Journal of Systematic and Evolutionary Microbiology*, **49**(3), 991-996.
- Brenner, K., You, L., Arnold, F.H. 2008. Engineering microbial consortia: a new frontier in synthetic biology. *Trends in Biotechnology*, **26**(9), 483-489.
- Brentner, L.B., Peccia, J., Zimmerman, J.B. 2010. Challenges in Developing Biohydrogen as a Sustainable Energy Source: Implications for a Research Agenda. *Environmental Science & Technology*, **44**(7), 2243-2254.
- Brown, A.D. 1976. Microbial water stress. *Bacteriological reviews*, **40**(4), 803-846.
- Brunecky, R., Alahuhta, M., Xu, Q., Donohoe, B.S., Crowley, M.F., Kataeva, I.A., Yang, S.-J., Resch, M.G., Adams, M.W.W., Lunin, V.V., Himmel, M.E., Bomble, Y.J. 2013. Revealing Nature’s Cellulase Diversity: The Digestion Mechanism of *Caldicellulosiruptor bescii* CelA. *Science*, **342**(6165), 1513-1516.
- Burgdorf, T., Löscher, S., Liebisch, P., Van der Linden, E., Galander, M., Lenzian, F., Meyer-Klaucke, W., Albracht, S.P.J., Friedrich, B., Dau, H., Haumann, M. 2005. Structural and Oxidation-State Changes at Its Nonstandard Ni–Fe Site during Activation of the NAD-Reducing Hydrogenase from *Ralstonia eutropha* Detected by X-ray Absorption, EPR, and FTIR Spectroscopy. *Journal of the American Chemical Society*, **127**(2), 576-592.
- Burmølle, M., Webb, J.S., Rao, D., Hansen, L.H., Sørensen, S.J., Kjelleberg, S. 2006. Enhanced Biofilm Formation and Increased Resistance to Antimicrobial Agents and Bacterial Invasion Are Caused by Synergistic Interactions in Multispecies Biofilms. *Applied and Environmental Microbiology*, **72**(6), 3916-3923.
- Bustos, G., Moldes, A.B., Cruz, J.M., Domínguez, J.M. 2004. Production of fermentable media from vine-trimming wastes and bioconversion into lactic acid by *Lactobacillus pentosus*. *Journal of the Science of Food and Agriculture*, **84**(15), 2105-2112.

- Carere, C.R., Rydzak, T., Verbeke, T.J., Cicek, N., Levin, D.B., Sparling, R. 2012. Linking genome content to biofuel production yields: a meta-analysis of major catabolic pathways among select H₂ and ethanol-producing bacteria. *BMC Microbiology*, **12**(1), 295.
- Carrillo-Reyes, J., Trably, E., Bernet, N., Latrille, E., Razo-Flores, E. 2016. High robustness of a simplified microbial consortium producing hydrogen in long term operation of a biofilm fermentative reactor. *International Journal of Hydrogen Energy*, **41**(4), 2367-2376.
- Carvalho, F., Duarte, L.C., Girio, F.M. 2008. Hemicellulose biorefineries: a review on biomass pretreatments. *Journal of Scientific & Industrial Research*, 849-864.
- Cha, M., Chung, D., Elkins, J.G., Guss, A.M., Westpheling, J. 2013. Metabolic engineering of *Caldicellulosiruptor bescii* yields increased hydrogen production from lignocellulosic biomass. *Biotechnology for Biofuels*, **6**(1), 85.
- Chaganti, S.R., Lalman, J.A., Heath, D.D. 2012. 16S rRNA gene based analysis of the microbial diversity and hydrogen production in three mixed anaerobic cultures. *International Journal of Hydrogen Energy*, **37**(11), 9002-9017.
- Chandra, R.P., Bura, R., Mabee, W.E., Berlin, A., Pan, X., Saddler, J.N. 2007. Substrate Pretreatment: The Key to Effective Enzymatic Hydrolysis of Lignocelluloses? in: *Biofuels*, (Ed.) L. Olsson, Springer Berlin Heidelberg. Berlin, Heidelberg, pp. 67-93.
- Chen, C.-C., Lin, C.-Y., Lin, M.-C. 2002. Acid-base enrichment enhances anaerobic hydrogen production process. *Applied Microbiology and Biotechnology*, **58**(2), 224-228.
- Chen, W.-M., Tseng, Z.-J., Lee, K.-S., Chang, J.-S. 2005. Fermentative hydrogen production with *Clostridium butyricum* CGS5 isolated from anaerobic sewage sludge. *International Journal of Hydrogen Energy*, **30**(10), 1063-1070.
- Chen, W.-S., Strik, D.P.B.T.B., Buisman, C.J.N., Kroeze, C. 2017. Production of Caproic Acid from Mixed Organic Waste: An Environmental Life Cycle Perspective. *Environmental science & technology*, **51**(12), 7159-7168.
- Cherubini, F. 2010. The biorefinery concept: Using biomass instead of oil for producing energy and chemicals. *Energy Conversion and Management*, **51**(7), 1412-1421.
- Chou, C.-J., Jenney Jr, F.E., Adams, M.W.W., Kelly, R.M. 2008. Hydrogenesis in hyperthermophilic microorganisms: Implications for biofuels. *Metabolic Engineering*, **10**(6), 394-404.
- Chung, D., Cha, M., Farkas, J., Westpheling, J. 2013a. Construction of a Stable Replicating Shuttle Vector for *Caldicellulosiruptor* Species: Use for Extending Genetic Methodologies to Other Members of This Genus. *PLOS ONE*, **8**(5), e62881.
- Chung, D., Farkas, J., Huddleston, J.R., Olivar, E., Westpheling, J. 2012. Methylation by a Unique α -class N4-Cytosine Methyltransferase Is Required for DNA Transformation of *Caldicellulosiruptor bescii* DSM6725. *PLOS ONE*, **7**(8), e43844.
- Chung, D., Farkas, J., Westpheling, J. 2013b. Overcoming restriction as a barrier to DNA transformation in *Caldicellulosiruptor* species results in efficient marker replacement. *Biotechnology for Biofuels*, **6**(1), 82.
- Claassen, P.A.M., van Lier, J.B., Lopez Contreras, A.M., van Niel, E.W.J., Sijtsma, L., Stams, A.J.M., de Vries, S.S., Weusthuis, R.A. 1999. Utilisation of biomass for

- the supply of energy carriers. *Applied Microbiology and Biotechnology*, **52**(6), 741-755.
- Clausen, A., Mikkelsen, M.J., Schröder, I., Ahring, B.K. 2004. Cloning, sequencing, and sequence analysis of two novel plasmids from the thermophilic anaerobic bacterium *Anaerocellum thermophilum*. *Plasmid*, **52**(2), 131-138.
- Cooney, M., Maynard, N., Cannizzaro, C., Benemann, J. 2007. Two-phase anaerobic digestion for production of hydrogen–methane mixtures. *Bioresource Technology*, **98**(14), 2641-2651.
- da Costa Sousa, L., Chundawat, S.P.S., Balan, V., Dale, B.E. 2009. ‘Cradle-to-grave’ assessment of existing lignocellulose pretreatment technologies. *Current Opinion in Biotechnology*, **20**(3), 339-347.
- Dam, P., Kataeva, I., Yang, S.-J., Zhou, F., Yin, Y., Chou, W., Poole, F.L., 2nd, Westpheling, J., Hettich, R., Giannone, R., Lewis, D.L., Kelly, R., Gilbert, H.J., Henrissat, B., Xu, Y., Adams, M.W.W. 2011. Insights into plant biomass conversion from the genome of the anaerobic thermophilic bacterium *Caldicellulosiruptor bescii* DSM 6725. *Nucleic acids research*, **39**(8), 3240-3254.
- Das, D. 2009. Advances in biohydrogen production processes: An approach towards commercialization. *International Journal of Hydrogen Energy*, **34**(17), 7349-7357.
- Das, D., Veziroğlu, T.N. 2001. Hydrogen production by biological processes: a survey of literature. *International Journal of Hydrogen Energy*, **26**(1), 13-28.
- Dawson, C.J., Hilton, J. 2011. Fertiliser availability in a resource-limited world: Production and recycling of nitrogen and phosphorus. *Food Policy*, **36**, S14-S22.
- de Jong, E., Jungmeier, G. 2015. Chapter 1 - Biorefinery Concepts in Comparison to Petrochemical Refineries. in: *Industrial Biorefineries & White Biotechnology*, (Eds.) A. Pandey, R. Höfer, M. Taherzadeh, K.M. Nampoothiri, C. Larroche, Elsevier. Amsterdam, pp. 3-33.
- De Visser, J.A.G.M., Rozen, D.E. 2005. Limits to adaptation in asexual populations. *Journal of Evolutionary Biology*, **18**(4), 779-788.
- de Vrije, T., Bakker, R.R., Budde, M.A., Lai, M.H., Mars, A.E., Claassen, P.A. 2009. Efficient hydrogen production from the lignocellulosic energy crop *Miscanthus* by the extreme thermophilic bacteria *Caldicellulosiruptor saccharolyticus* and *Thermotoga neapolitana*. *Biotechnology for Biofuels*, **2**(1), 12.
- de Vrije, T., Budde, M.A.W., Lips, S.J., Bakker, R.R., Mars, A.E., Claassen, P.A.M. 2010. Hydrogen production from carrot pulp by the extreme thermophiles *Caldicellulosiruptor saccharolyticus* and *Thermotoga neapolitana*. *International Journal of Hydrogen Energy*, **35**(24), 13206-13213.
- de Vrije, T., Mars, A.E., Budde, M.A.W., Lai, M.H., Dijkema, C., de Waard, P., Claassen, P.A.M. 2007. Glycolytic pathway and hydrogen yield studies of the extreme thermophile *Caldicellulosiruptor saccharolyticus*. *Applied Microbiology and Biotechnology*, **74**(6), 1358.
- Demirbas, A. 2009. Biofuels securing the planet’s future energy needs. *Energy Conversion and Management*, **50**(9), 2239-2249.
- Demirbaş, A. 2000. Mechanisms of liquefaction and pyrolysis reactions of biomass. *Energy Conversion and Management*, **41**(6), 633-646.

- Dessi, P., Lakaniemi, A.-M., Lens, P.N.L. 2017. Biohydrogen production from xylose by fresh and digested activated sludge at 37, 55 and 70 °C. *Water Research*, **115**, 120-129.
- Ding, J., Wang, X., Zhou, X.-F., Ren, N.-Q., Guo, W.-Q. 2010. CFD optimization of continuous stirred-tank (CSTR) reactor for biohydrogen production. *Bioresource Technology*, **101**(18), 7005-7013.
- Dipasquale, L., Adessi, A., d'Ippolito, G., Rossi, F., Fontana, A., De Philippis, R. 2015. Introducing capnophilic lactic fermentation in a combined dark-photo fermentation process: a route to unparalleled H₂ yields. *Applied Microbiology and Biotechnology*, **99**(2), 1001-1010.
- Dragosits, M., Mattanovich, D. 2013. Adaptive laboratory evolution – principles and applications for biotechnology. *Microbial Cell Factories*, **12**(1), 64.
- Dutta, K., Daverey, A., Lin, J.-G. 2014. Evolution retrospective for alternative fuels: First to fourth generation. *Renewable Energy*, **69**, 114-122.
- Elsharnouby, O., Hafez, H., Nakhla, G., El Nagggar, M.H. 2013. A critical literature review on biohydrogen production by pure cultures. *International Journal of Hydrogen Energy*, **38**(12), 4945-4966.
- Elshout, P.M.F., van Zelm, R., Balkovic, J., Obersteiner, M., Schmid, E., Skalsky, R., van der Velde, M., Huijbregts, M.A.J. 2015. Greenhouse-gas payback times for crop-based biofuels. *Nature Climate Change*, **5**, 604.
- European Commission. 2012. *Energy roadmap 2050*. Publications Office of the European Union.
- European Commission. 2014. A policy framework for climate and energy in the period from 2020 to 2030. *Technical Report COM (2014) 15*.
- European Parliament. 2018. *Promoting renewable energy sources in the EU after 2020*.
- European Parliament and Council. 2015. Directive (EU) 2015/1513 of the European parliament and of the council of 9 September 2015 amending Directive 98/70/EC relating to the quality of petrol and diesel fuels and amending Directive 2009/28/EC on the promotion of the use of energy from renewable sources, Official Journal of the European Union.
- Farkas, J., Chung, D., Cha, M., Copeland, J., Grayeski, P., Westpheling, J. 2013. Improved growth media and culture techniques for genetic analysis and assessment of biomass utilization by *Caldicellulosiruptor bescii*. *Journal of Industrial Microbiology & Biotechnology*, **40**(1), 41-49.
- Felsenstein, J. 1974. The evolutionary advantage of recombination. *Genetics*, **78**(2), 737-756.
- Ferry, J.G. 1992. Methane from acetate. *Journal of Bacteriology*, **174**(17), 5489-5495.
- Foglia, D., Ljunggren, M., Wukovits, W., Friedl, A., Zacchi, G., Urbaniec, K., Markowski, M. 2010. Integration studies on a two-stage fermentation process for the production of biohydrogen. *Journal of Cleaner Production*, **18**, S72-S80.
- Fu, N., Peiris, P. 2008. Co-fermentation of a mixture of glucose and xylose to ethanol by *Zymomonas mobilis* and *Pachysolen tannophilus*. *World Journal of Microbiology and Biotechnology*, **24**(7), 1091-1097.
- Gong, Z., Zhou, W., Shen, H., Yang, Z., Wang, G., Zuo, Z., Hou, Y., Zhao, Z.K. 2016. Co-fermentation of acetate and sugars facilitating microbial lipid production on acetate-rich biomass hydrolysates. *Bioresource Technology*, **207**, 102-108.

- Goud, R.K., Raghavulu, S.V., Mohanakrishna, G., Naresh, K., Mohan, S.V. 2012. Predominance of Bacilli and Clostridia in microbial community of biohydrogen producing biofilm sustained under diverse acidogenic operating conditions. *International Journal of Hydrogen Energy*, **37**(5), 4068-4076.
- Gray, C.T., Gest, H. 1965. Biological Formation of Molecular Hydrogen. A "hydrogen valve" facilitates regulation of anaerobic energy metabolism in many microorganisms, **148**(3667), 186-192.
- Groom, J., Chung, D., Young, J., Westpheling, J. 2014. Heterologous complementation of a pyrF deletion in *Caldicellulosiruptor hydrothermalis* generates a new host for the analysis of biomass deconstruction. *Biotechnology for Biofuels*, **7**(1), 132.
- Guo, M., Song, W., Buhain, J. 2015. Bioenergy and biofuels: History, status, and perspective. *Renewable and Sustainable Energy Reviews*, **42**, 712-725.
- Hadar, Y. 2013. Sources for Lignocellulosic Raw Materials for the Production of Ethanol. in: *Lignocellulose Conversion: Enzymatic and Microbial Tools for Bioethanol Production*, (Ed.) V. Faraco, Springer Berlin Heidelberg. Berlin, Heidelberg, pp. 21-38.
- Hallenbeck, P.C. 2009. Fermentative hydrogen production: Principles, progress, and prognosis. *International Journal of Hydrogen Energy*, **34**(17), 7379-7389.
- Hallenbeck, P.C. 2012. Hydrogen Production by Cyanobacteria. in: *Microbial Technologies in Advanced Biofuels Production*, (Ed.) P.C. Hallenbeck, Springer US. Boston, MA, pp. 15-28.
- Hallenbeck, P.C. 2011. Microbial paths to renewable hydrogen production. *Biofuels*, **2**(3), 285-302.
- Hallenbeck, P.C., Benemann, J.R. 2002. Biological hydrogen production: fundamentals and limiting processes. *International Journal of Hydrogen Energy*, **27**.
- Hallenbeck, P.C., Ghosh, D. 2009. Advances in fermentative biohydrogen production: the way forward? *Trends in Biotechnology*, **27**.
- Hamelinck, C.N., Hooijdonk, G.v., Faaij, A.P.C. 2005. Ethanol from lignocellulosic biomass: techno-economic performance in short-, middle- and long-term. *Biomass and Bioenergy*, **28**(4), 384-410.
- Hamilton-Brehm, S.D., Mosher, J.J., Vishnivetskaya, T., Podar, M., Carroll, S., Allman, S., Phelps, T.J., Keller, M., Elkins, J.G. 2010. *Caldicellulosiruptor obsidiansis* sp. nov., an Anaerobic, Extremely Thermophilic, Cellulolytic Bacterium Isolated from Obsidian Pool, Yellowstone National Park. *Applied and Environmental Microbiology*, **76**(4), 1014.
- Hardin, G. 1960. The Competitive Exclusion Principle. *Science*, **131**(3409), 1292-1297.
- Havlík, P., Schneider, U.A., Schmid, E., Böttcher, H., Fritz, S., Skalský, R., Aoki, K., Cara, S.D., Kindermann, G., Kraxner, F., Leduc, S., McCallum, I., Mosnier, A., Sauer, T., Obersteiner, M. 2011. Global land-use implications of first and second generation biofuel targets. *Energy Policy*, **39**(10), 5690-5702.
- He, C.-R., Kuo, Y.-Y., Li, S.-Y. 2017. Lignocellulosic butanol production from Napier grass using semi-simultaneous saccharification fermentation. *Bioresource Technology*, **231**, 101-108.
- Hendriks, A.T.W.M., Zeeman, G. 2009. Pretreatments to enhance the digestibility of lignocellulosic biomass. *Bioresource Technology*, **100**(1), 10-18.

- Himmel, M.E., Ding, S.Y., Johnson, D.K., Adney, W.S., Nimlos, M.R., Brady, J.W., Foust, T.D. 2007. Biomass recalcitrance: engineering plants and enzymes for biofuels production. *Science*, **315**(5813), 804-7.
- Holst, O., Manelius, Å., Krahe, M., Märkl, H., Raven, N., Sharp, R. 1997. Thermophiles and fermentation technology. *Comparative Biochemistry and Physiology Part A: Physiology*, **118**(3), 415-422.
- Hornung, A. 2014. Bio-Hydrogen from Biomass. in: *Transformation of Biomass*.
- Huang, C.-Y., Patel, B.K., Mah, R.A., Baresi, L. 1998. *Caldicellulosiruptor owensensis* sp. nov., an anaerobic, extremely thermophilic, xylanolytic bacterium. *International Journal of Systematic and Evolutionary Microbiology*, **48**(1), 91-97.
- Huang, H.-j., Yuan, X.-z. 2015. Recent progress in the direct liquefaction of typical biomass. *Progress in Energy and Combustion Science*, **49**, 59-80.
- Huesemann, M.H., Hausmann, T.S., Carter, B.M., Gerschler, J.J., Benemann, J.R. 2010. Hydrogen Generation Through Indirect Biophotolysis in Batch Cultures of the Nonheterocystous Nitrogen-Fixing Cyanobacterium *Plectonema boryanum*. *Applied Biochemistry and Biotechnology*, **162**(1), 208-220.
- Ingvadottir, E.M., Scully, S.M., Orlygsson, J. 2017. Evaluation of the genus of *Caldicellulosiruptor* for production of 1,2-propanediol from methylpentoses. *Anaerobe*, **47**, 86-88.
- International Energy Agency. 2017a. Key world energy statistics 2017, International Energy Agency.
- International Energy Agency. 2017b. Tracking Clean Energy Progress 2017, International Energy Agency.
- Jermyn, M.A. 1955. Cellulose and Hemicelluloses. in: *Modern Methods of Plant Analysis / Moderne Methoden der Pflanzenanalyse*, (Eds.) K. Paech, M.V. Tracey, Springer Berlin Heidelberg. Berlin, Heidelberg, pp. 197-225.
- Jessen, J.E., Orlygsson, J. 2012. Production of ethanol from sugars and lignocellulosic biomass by *Thermoanaerobacter* J1 isolated from a hot spring in Iceland. *Journal of biomedicine & biotechnology*, **2012**, 186982-186982.
- Johansen, E. 2018. Use of Natural Selection and Evolution to Develop New Starter Cultures for Fermented Foods. *Annual Review of Food Science and Technology*, **9**(1), 411-428.
- Jungermann, K., Thauer, R.K., Leimenstoll, G., Decker, K. 1973. Function of reduced pyridine nucleotide-ferredoxin oxidoreductases in saccharolytic Clostridia. *Biochimica et Biophysica Acta (BBA) - Bioenergetics*, **305**(2), 268-280.
- Kapdan, I.K., Kargi, F. 2006. Bio-hydrogen production from waste materials. *Enzyme and Microbial Technology*, **38**(5), 569-582.
- Karadag, D., Puhakka, J.A. 2010. Effect of changing temperature on anaerobic hydrogen production and microbial community composition in an open-mixed culture bioreactor. *International Journal of Hydrogen Energy*, **35**(20), 10954-10959.
- Kawaguchi, H., Hasunuma, T., Ogino, C., Kondo, A. 2016. Bioprocessing of bio-based chemicals produced from lignocellulosic feedstocks. *Current Opinion in Biotechnology*, **42**, 30-39.
- Keasling, J.D., Benemann, J., Pramanik, J., Carrier, T.A., Jones, K.L., Van Dien, S.J. 1998. A Toolkit for Metabolic Engineering of Bacteria. in: *BioHydrogen*, (Eds.)

- O.R. Zaborsky, J.R. Benemann, T. Matsunaga, J. Miyake, A. San Pietro, Springer US. Boston, MA, pp. 87-97.
- Kempf, B., Bremer, E. 1998. Stress responses of *Bacillus subtilis* to high osmolarity environments: Uptake and synthesis of osmoprotectants. *Journal of Biosciences*, **23**(4), 447-455.
- Kengen, S.W.M., Goorissen, H.P., Verhaart, M., Stams, A.J.M., van Niel, E.W.J., Claassen, P.A.M. 2009. Biological hydrogen production by anaerobic microorganisms. in: *Biofuels*, (Eds.) W. Soetaert, E.J. Vandamme, Sons. Chichester, UK.
- Khanna, N., Das, D. 2013. Biohydrogen production by dark fermentation. *Wiley Interdisciplinary Reviews: Energy and Environment*, **2**(4), 401-421.
- Kim, J.-H., Block, D.E., Mills, D.A. 2010. Simultaneous consumption of pentose and hexose sugars: an optimal microbial phenotype for efficient fermentation of lignocellulosic biomass. *Applied Microbiology and Biotechnology*, **88**(5), 1077-1085.
- Kleinert, M., Barth, T. 2008. Towards a Lignocellulosic Biorefinery: Direct One-Step Conversion of Lignin to Hydrogen-Enriched Biofuel. *Energy & Fuels*, **22**(2), 1371-1379.
- Kodama, T., Minoda, Y. 1977. Isolation and Culture Conditions of Thermophilic Hydrogen Bacteria AU - Goto, Eiji. *Agricultural and Biological Chemistry*, **41**(4), 685-690.
- Kosourov, S., Tsygankov, A., Seibert, M., Ghirardi, M.L. 2002. Sustained hydrogen photoproduction by *Chlamydomonas reinhardtii*: Effects of culture parameters. *Biotechnology and Bioengineering*, **78**(7), 731-740.
- Kotsopoulos, T.A., Zeng, R.J., Angelidaki, I. 2006. Biohydrogen production in granular up-flow anaerobic sludge blanket (UASB) reactors with mixed cultures under hyper-thermophilic temperature (70°C). *Biotechnology and Bioengineering*, **94**(2), 296-302.
- Kovács, K.L., Maróti, G., Rákhely, G. 2006. A novel approach for biohydrogen production. *International Journal of Hydrogen Energy*, **31**(11), 1460-1468.
- Kraemer, J.T., Bagley, D.M. 2006. Supersaturation of Dissolved H₂ and CO₂ During Fermentative Hydrogen Production with N₂ Sparging. *Biotechnology Letters*, **28**(18), 1485-1491.
- Kridelbaugh, D.M., Nelson, J., Engle, N.L., Tschaplinski, T.J., Graham, D.E. 2013. Nitrogen and sulfur requirements for *Clostridium thermocellum* and *Caldicellulosiruptor bescii* on cellulosic substrates in minimal nutrient media. *Bioresource Technology*, **130**, 125-135.
- Krull, S., Eidt, L., Hevekerl, A., Kuenz, A., Prübe, U. 2017. Itaconic acid production from wheat chaff by *Aspergillus terreus*. *Process Biochemistry*, **63**, 169-176.
- Kumar, A., Jones, D., Hanna, M. 2009a. Thermochemical Biomass Gasification: A Review of the Current Status of the Technology. *Energies*, **2**(3), 556.
- Kumar, A.K., Sharma, S. 2017. Recent updates on different methods of pretreatment of lignocellulosic feedstocks: a review. *Bioresources and Bioprocessing*, **4**(1), 7.
- Kumar, N., Das, D. 2000. Enhancement of hydrogen production by *Enterobacter cloacae* IIT-BT 08. *Process Biochemistry*, **35**(6), 589-593.

- Kumar, P., Barrett, D.M., Delwiche, M.J., Stroeve, P. 2009b. Methods for Pretreatment of Lignocellulosic Biomass for Efficient Hydrolysis and Biofuel Production. *Industrial & Engineering Chemistry Research*, **48**(8), 3713-3729.
- LaPara, T.M., Zakharova, T., Nakatsu, C.H., Konopka, A. 2002. Functional and Structural Adaptations of Bacterial Communities Growing on Particulate Substrates under Stringent Nutrient Limitation. *Microbial Ecology*, **44**(4), 317-326.
- Lapola, D.M., Schaldach, R., Alcamo, J., Bondeau, A., Koch, J., Koelking, C., Priess, J.A. 2010. Indirect land-use changes can overcome carbon savings from biofuels in Brazil. *Proceedings of the National Academy of Sciences*, **107**(8), 3388-3393.
- Latif, H., Sahin, M., Tarasova, J., Tarasova, Y., Portnoy, V.A., Nogales, J., Zengler, K. 2015. Adaptive Evolution of *Thermotoga maritima*; Reveals Plasticity of the ABC Transporter Network. *Applied and Environmental Microbiology*, **81**(16), 5477.
- Lay, J.-J., Lee, Y.-J., Noike, T. 1999. Feasibility of biological hydrogen production from organic fraction of municipal solid waste. *Water Research*, **33**(11), 2579-2586.
- Lee, L.L., Blumer-Schuette, S.E., Izquierdo, J.A., Zurawski, J.V., Loder, A.J., Conway, J.M., Elkins, J.G., Podar, M., Clum, A., Jones, P.C., Piatek, M.J., Weighill, D.A., Jacobson, D.A., Adams, M.W.W., Kelly, R.M. 2018. Genus-Wide Assessment of Lignocellulose Utilization in the Extremely Thermophilic Genus *Caldicellulosiruptor* by Genomic, Pangenomic, and Metagenomic Analyses. *Applied and Environmental Microbiology*, **84**(9).
- Lee, L.L., Izquierdo, J.A., Blumer-Schuette, S.E., Zurawski, J.V., Conway, J.M., Cottingham, R.W., Huntemann, M., Copeland, A., Chen, I.-M.A., Kyrpides, N., Markowitz, V., Palaniappan, K., Ivanova, N., Mikhailova, N., Ovchinnikova, G., Andersen, E., Pati, A., Stamatis, D., Reddy, T.B.K., Shapiro, N., Nordberg, H.P., Cantor, M.N., Hua, S.X., Woyke, T., Kelly, R.M. 2015. Complete Genome Sequences of *Caldicellulosiruptor* sp. Strain Rt8.B8, *Caldicellulosiruptor* sp. Strain Wai35.B1, and “*Thermoanaerobacter cellulolyticus*”. *Genome Announcements*, **3**(3).
- Lenihan, P., Orozco, A., O’Neill, E., Ahmad, M.N.M., Rooney, D.W., Walker, G.M. 2010. Dilute acid hydrolysis of lignocellulosic biomass. *Chemical Engineering Journal*, **156**(2), 395-403.
- Levin, D.B., Pitt, L., Love, M. 2004. Biohydrogen production: prospects and limitations to practical application. *International Journal of Hydrogen Energy*, **29**(2), 173-185.
- Li, L., Li, K., Wang, K., Chen, C., Gao, C., Ma, C., Xu, P. 2014. Efficient production of 2,3-butanediol from corn stover hydrolysate by using a thermophilic *Bacillus licheniformis* strain. *Bioresource Technology*, **170**, 256-261.
- Liu, D., Liu, D., Zeng, R.J., Angelidaki, I. 2006. Hydrogen and methane production from household solid waste in the two-stage fermentation process. *Water Research*, **40**(11), 2230-2236.
- Liu, D., Sun, Y., Li, Y., Lu, Y. 2017. Perturbation of formate pathway and NADH pathway acting on the biohydrogen production. *Scientific Reports*, **7**(1), 9587.
- Liu, Y., Yu, P., Song, X., Qu, Y. 2008. Hydrogen production from cellulose by co-culture of *Clostridium thermocellum* JN4 and *Thermoanaerobacterium thermosaccharolyticum* GD17. *International Journal of Hydrogen Energy*, **33**.

- Ljunggren, M., Wallberg, O., Zacchi, G. 2011a. Techno-economic comparison of a biological hydrogen process and a 2nd generation ethanol process using barley straw as feedstock. *Bioresource Technology*, **102**.
- Ljunggren, M., Willquist, K., Zacchi, G., van Niel, E.W. 2011b. A kinetic model for quantitative evaluation of the effect of hydrogen and osmolarity on hydrogen production by *Caldicellulosiruptor saccharolyticus*. *Biotechnology for Biofuels*, **4**(1), 31.
- Ljunggren, M., Zacchi, G. 2010a. Techno-economic analysis of a two-step biological process producing hydrogen and methane. *Bioresource Technology*, **101**(20), 7780-7788.
- Ljunggren, M., Zacchi, G. 2010b. Techno-economic evaluation of a two-step biological process for hydrogen production. *Biotechnol Prog*, **26**.
- Luidold, S., Antrekowitsch, H. 2007. Hydrogen as a reducing agent: State-of-the-art science and technology. *JOM*, **59**(6), 20-26.
- Lukey, M.J., Roessler, M.M., Parkin, A., Evans, R.M., Davies, R.A., Lenz, O., Friedrich, B., Sargent, F., Armstrong, F.A. 2011. Oxygen-Tolerant [NiFe]-Hydrogenases: The Individual and Collective Importance of Supernumerary Cysteines at the Proximal Fe-S Cluster. *Journal of the American Chemical Society*, **133**(42), 16881-16892.
- Lynd, L.R., Elamder, R.T., Wyman, C.E. 1996. Likely features and costs of mature biomass ethanol technology. *Applied Biochemistry and Biotechnology*, **57**(1), 741-761.
- Mabee, W.E., McFarlane, P.N., Saddler, J.N. 2011. Biomass availability for lignocellulosic ethanol production. *Biomass and Bioenergy*, **35**(11), 4519-4529.
- Machado, R.G., Moreira, F.S., Batista, F.R.X., Ferreira, J.S., Cardoso, V.L. 2018. Repeated batch cycles as an alternative for hydrogen production by co-culture photofermentation. *Energy*, **153**, 861-869.
- Maity, J.P., Bundschuh, J., Chen, C.-Y., Bhattacharya, P. 2014. Microalgae for third generation biofuel production, mitigation of greenhouse gas emissions and wastewater treatment: Present and future perspectives – A mini review. *Energy*, **78**, 104-113.
- Mars, A.E., Veuskens, T., Budde, M.A.W., van Doeveren, P.F.N.M., Lips, S.J., Bakker, R.R., de Vrije, T., Claassen, P.A.M. 2010. Biohydrogen production from untreated and hydrolyzed potato steam peels by the extreme thermophiles *Caldicellulosiruptor saccharolyticus* and *Thermotoga neapolitana*. *International Journal of Hydrogen Energy*, **35**(15), 7730-7737.
- Martinez-Porqueras, E., Wechselberger, P., Herwig, C. 2013. Effect of medium composition on biohydrogen production by the extreme thermophilic bacterium *Caldicellulosiruptor saccharolyticus*. *International Journal of Hydrogen Energy*, **38**(27), 11756-11764.
- McDowall, J.S., Murphy, B.J., Haumann, M., Palmer, T., Armstrong, F.A., Sargent, F. 2014. Bacterial formate hydrogenlyase complex. *Proceedings of the National Academy of Sciences*, **111**(38), E3948-E3956.
- McKendry, P. 2002. Energy production from biomass (part 1): overview of biomass. *Bioresource Technology*, **83**(1), 37-46.
- McKinlay, J.B., Harwood, C.S. 2010. Photobiological production of hydrogen gas as a biofuel. *Current Opinion in Biotechnology*, **21**(3), 244-251.

- Meher Kotay, S., Das, D. 2008. Biohydrogen as a renewable energy resource—Prospects and potentials. *International Journal of Hydrogen Energy*, **33**(1), 258-263.
- Miroshnichenko, M.L., Kublanov, I.V., Kostrikina, N.A., Tourova, T.P., Kolganova, T.V., Birkeland, N.-K., Bonch-Osmolovskaya, E.A. 2008. *Caldicellulosiruptor kronotskyensis* sp. nov. and *Caldicellulosiruptor hydrothermalis* sp. nov., two extremely thermophilic, cellulolytic, anaerobic bacteria from Kamchatka thermal springs. *International Journal of Systematic and Evolutionary Microbiology*, **58**(6), 1492-1496.
- Miura, M., Watanabe, I., Shimotori, Y., Aoyama, M., Kojima, Y., Kato, Y. 2013. Microbial conversion of bamboo hemicellulose hydrolysate to xylitol. *Wood Science and Technology*, **47**(3), 515-522.
- Mladenovska, Z., Mathrani, I.M., Ahring, B.K. 1995. Isolation and characterization of *Caldicellulosiruptor lactoaceticus* sp. nov., an extremely thermophilic, cellulolytic, anaerobic bacterium. *Archives of Microbiology*, **163**(3), 223-230.
- Morjanoff, P.J., Gray, P.P. 1987. Optimization of steam explosion as a method for increasing susceptibility of sugarcane bagasse to enzymatic saccharification. *Biotechnology and Bioengineering*, **29**(6), 733-741.
- Mosier, N., Wyman, C.E., Dale, B., Elander, R., Lee, Y.Y., Holtzapple, M., Ladisch, M. 2005. Features of promising technologies for pretreatment of lignocellulosic biomass. *Bioresource Technology*, **96**.
- Muller, H.J. 1964. The relation of recombination to mutational advance. *Mutation Research/Fundamental and Molecular Mechanisms of Mutagenesis*, **1**(1), 2-9.
- Muller, H.J. 1932. Some Genetic Aspects of Sex. *The American Naturalist*, **66**(703), 118-138.
- Naik, S.N., Goud, V.V., Rout, P.K., Dalai, A.K. 2010. Production of first and second generation biofuels: A comprehensive review. *Renewable and Sustainable Energy Reviews*, **14**(2), 578-597.
- Nandi, R., Sengupta, S. 1998. Microbial Production of Hydrogen: An Overview. *Critical Reviews in Microbiology*, **24**(1), 61-84.
- Nath, K., Das, D. 2004. Improvement of fermentative hydrogen production: various approaches. *Applied Microbiology and Biotechnology*, **65**(5), 520-529.
- Nielsen, H.B., Mladenovska, Z., Ahring, B.K. 2007. Bioaugmentation of a two-stage thermophilic (68°C/55°C) anaerobic digestion concept for improvement of the methane yield from cattle manure. *Biotechnology and Bioengineering*, **97**(6), 1638-1643.
- Nielsen, P., Mathrani, I.M., Ahring, B.K. 1993. *Thermoanaerobium acetigenum* spec. nov., a new anaerobic, extremely thermophilic, xylanolytic non-spore-forming bacterium isolated from an Icelandic hot spring. *Archives of Microbiology*, **159**(5), 460-464.
- Nikhil, G.N., Sarkar, O., Venkata Mohan, S. 2017. Biohydrogen Production: An Outlook of Fermentative Processes and Integration Strategies. in: *Optimization and Applicability of Bioprocesses*, (Eds.) H.J. Purohit, V.C. Kalia, A.N. Vaidya, A.A. Khardenavis, Springer Singapore. Singapore, pp. 249-265.
- Ntaikou, I., Antonopoulou, G., Lyberatos, G. 2010. Biohydrogen Production from Biomass and Wastes via Dark Fermentation: A Review. *Waste and Biomass Valorization*, **1**(1), 21-39.

- Octave, S., Thomas, D. 2009. Biorefinery: Toward an industrial metabolism. *Biochimie*, **91**(6), 659-664.
- Oh, Y.-K., Raj, S.M., Jung, G.Y., Park, S. 2013. Chapter 3 - Metabolic Engineering of Microorganisms for Biohydrogen Production. in: *Biohydrogen*, (Eds.) A. Pandey, J.-S. Chang, P.C. Hallenbeck, C. Larroche, Elsevier. Amsterdam, pp. 45-65.
- Ollivier, B.M., Mah, R.A., Ferguson, T.J., Boone, D.R., Garcia, J.L., Robinson, R. 1985. Emendation of the Genus *Thermobacteroides*: *Thermobacteroides proteolyticus* sp. nov., a Proteolytic Acetogen from a Methanogenic Enrichment. *International Journal of Systematic and Evolutionary Microbiology*, **35**(4), 425-428.
- Olson, D.G., McBride, J.E., Joe Shaw, A., Lynd, L.R. 2012. Recent progress in consolidated bioprocessing. *Current Opinion in Biotechnology*, **23**(3), 396-405.
- Onyenwoke, R.U., Lee, Y.-J., Dabrowski, S., Ahring, B.K., Wiegel, J. 2006. Reclassification of *Thermoanaerobium acetigenum* as *Caldicellulosiruptor acetigenus* comb. nov. and emendation of the genus description. *International Journal of Systematic and Evolutionary Microbiology*, **56**(6), 1391-1395.
- Paerl, H.W., Pinckney, J.L. 1996. A Mini-Review of Microbial Consortia: Their Roles in Aquatic Production and Biogeochemical Cycling. *Microbial Ecology*, **31**(3), 225-247.
- Palmqvist, E., Hahn-Hägerdal, B. 2000. Fermentation of lignocellulosic hydrolysates. II: inhibitors and mechanisms of inhibition. *Bioresource Technology*, **74**(1), 25-33.
- Panagiotopoulos, I.A., Bakker, R.R., de Vrije, T., Koukios, E.G., Claassen, P.A.M. 2010. Pretreatment of sweet sorghum bagasse for hydrogen production by *Caldicellulosiruptor saccharolyticus*. *International Journal of Hydrogen Energy*, **35**(15), 7738-7747.
- Panwar, N.L., Kothari, R., Tyagi, V.V. 2012. Thermo chemical conversion of biomass – Eco friendly energy routes. *Renewable and Sustainable Energy Reviews*, **16**(4), 1801-1816.
- Parisutham, V., Kim, T.H., Lee, S.K. 2014. Feasibilities of consolidated bioprocessing microbes: From pretreatment to biofuel production. *Bioresource Technology*, **161**, 431-440.
- Parte, A.C. 2014. LPSN--list of prokaryotic names with standing in nomenclature. *Nucleic acids research*, **42**(Database issue), D613-D616.
- Pawar, S.S. 2014. *Caldicellulosiruptor saccharolyticus*: an Ideal Hydrogen Producer? *Faculty of Engineering, LTH, PhD Thesis*
- Pawar, S.S., Niel, E.W.J. 2013. Thermophilic biohydrogen production: how far are we? *Applied Microbiology and Biotechnology*, **97**.
- Pawar, S.S., Nkemka, V.N., Zeidan, A.A., Murto, M., van Niel, E.W.J. 2013. Biohydrogen production from wheat straw hydrolysate using *Caldicellulosiruptor saccharolyticus* followed by biogas production in a two-step uncoupled process. *International Journal of Hydrogen Energy*, **38**(22), 9121-9130.
- Pawar, S.S., van Niel, E.W.J. 2014. Evaluation of assimilatory sulphur metabolism in *Caldicellulosiruptor saccharolyticus*. *Bioresource Technology*, **169**, 677-685.
- Pawar, S.S., Vongkumpeang, T., Grey, C., van Niel, E.W. 2015. Biofilm formation by designed co-cultures of *Caldicellulosiruptor* species as a means to improve hydrogen productivity. *Biotechnology for Biofuels*, **8**(1), 19.

- Peabody, G., Winkler, J., Fountain, W., Castro, D.A., Leiva-Aravena, E., Kao, K.C. 2016. Benefits of a Recombination-Proficient *Escherichia coli* System for Adaptive Laboratory Evolution. *Applied and environmental microbiology*, **82**(22), 6736-6747.
- Peintner, C., Zeidan, A.A., Schnitzhofer, W. 2010. Bioreactor systems for thermophilic fermentative hydrogen production: evaluation and comparison of appropriate systems. *Journal of Cleaner Production*, **18**, S15-S22.
- Pérez, J., Muñoz-Dorado, J., de la Rubia, T., Martínez, J. 2002. Biodegradation and biological treatments of cellulose, hemicellulose and lignin: an overview. *International Microbiology*, **5**(2), 53-63.
- Pilak, O., Mamat, B., Vogt, S., Hagemeyer, C.H., Thauer, R.K., Shima, S., Vonrhein, C., Warkentin, E., Ermler, U. 2006. The Crystal Structure of the Apoenzyme of the Iron–Sulphur Cluster-free Hydrogenase. *Journal of Molecular Biology*, **358**(3), 798-809.
- Poon, A., Otto, S.P. 2000. Compensating for our load of mutations: Freezing the meltdown of small populations. *Evolution*, **54**(5), 1467-1479.
- Qureshi, N., Annous, B.A., Ezeji, T.C., Karcher, P., Maddox, I.S. 2005. Biofilm reactors for industrial bioconversion processes: employing potential of enhanced reaction rates. *Microbial Cell Factories*, **4**(1), 24.
- Rainey, F.A., Donnison, A.M., Janssen, P.H., Saul, D., Rodrigo, A., Bergquist, P.L., Daniel, R.M., Stackebrandt, E., Morgan, H.W. 1994. Description of *Caldicellulosiruptor saccharolyticus* gen. nov., sp. nov: An obligately anaerobic, extremely thermophilic, cellulolytic bacterium. *FEMS Microbiology Letters*, **120**(3), 263-266.
- Rinaldi, R., Schüth, F. 2009. Design of solid catalysts for the conversion of biomass. *Energy & Environmental Science*, **2**(6), 610-626.
- Rogoff, M.H., Rawlins, S.L. 1987. Food Security: A Technological Alternative. *BioScience*, **37**(11), 800-807.
- Ruan, Z., Zanotti, M., Zhong, Y., Liao, W., Ducey, C., Liu, Y. 2013. Co-hydrolysis of lignocellulosic biomass for microbial lipid accumulation. *Biotechnology and Bioengineering*, **110**(4), 1039-1049.
- Sánchez, C. 2009. Lignocellulosic residues: Biodegradation and bioconversion by fungi. *Biotechnology Advances*, **27**(2), 185-194.
- Sanderson, K. 2011. Lignocellulose: A chewy problem. *Nature*, **474**, S12.
- Saratale, G.D., Oh, M.-K. 2015. Characterization of poly-3-hydroxybutyrate (PHB) produced from *Ralstonia eutropha* using an alkali-pretreated biomass feedstock. *International Journal of Biological Macromolecules*, **80**, 627-635.
- Schleifer, K.-H. 2009. Phylum XIII. Firmicutes Gibbons and Murray 1978, 5 (Firmacutes [sic] Gibbons and Murray 1978, 5). in: *Bergey's Manual® of Systematic Bacteriology*, Springer, pp. 19-1317.
- Schädel, C., Blöchl, A., Richter, A., Hoch, G. 2010. Quantification and monosaccharide composition of hemicelluloses from different plant functional types. *Plant Physiology and Biochemistry*, **48**(1), 1-8.
- Searchinger, T., Heimlich, R., Houghton, R.A., Dong, F., Elobeid, A., Fabiosa, J., Tokgoz, S., Hayes, D., Yu, T.-H. 2008. Use of U.S. Croplands for Biofuels Increases Greenhouse Gases Through Emissions from Land-Use Change. *Science*, **319**(5867), 1238-1240.

- Sherrard, E.C., Kressman, F.W. 1945. Review of Processes in the United States Prior to World War II. *Industrial & Engineering Chemistry*, **37**(1), 5-8.
- Shirai, Y., Umeki, H., Yamazumi, H., Jin, S., Yamamoto, S., Karim, M.I.A., Nakanishi, K., Hashimoto, K. 1997. Acetic Acid Separation from Anaerobically Treated Palm Oil Mill Effluent by Ion Exchange Resins for the Production of Polyhydroxyalkanoate by *Alcaligenes eutrophus* AU - Hassan, Mohd. Ali. *Bioscience, Biotechnology, and Biochemistry*, **61**(9), 1465-1468.
- Show, K.-Y., Lee, D.-J. 2013. Chapter 13 - Bioreactor and Bioprocess Design for Biohydrogen Production. in: *Biohydrogen*, (Eds.) A. Pandey, J.-S. Chang, P.C. Hallenbeck, C. Larroche, Elsevier. Amsterdam, pp. 317-337.
- Shui, Z.-X., Qin, H., Wu, B., Ruan, Z.-y., Wang, L.-s., Tan, F.-R., Wang, J.-L., Tang, X.-Y., Dai, L.-C., Hu, G.-Q., He, M.-X. 2015. Adaptive laboratory evolution of ethanologenic *Zymomonas mobilis* strain tolerant to furfural and acetic acid inhibitors. *Applied Microbiology and Biotechnology*, **99**(13), 5739-5748.
- Sims, R., Taylor, M., Saddler, J., Mabee, W. 2008. From 1st-to 2nd-generation biofuel technologies. *Paris: International Energy Agency (IEA) and Organisation for Economic Co-Operation and Development*.
- Sims, R.E.H., Mabee, W., Saddler, J.N., Taylor, M. 2010. An overview of second generation biofuel technologies. *Bioresource Technology*, **101**(6), 1570-1580.
- Sindhu, R., Binod, P., Pandey, A. 2016. Biological pretreatment of lignocellulosic biomass – An overview. *Bioresource Technology*, **199**, 76-82.
- Sissons, C.H., Sharrock, K.R., Daniel, R.M., Morgan, H.W. 1987. Isolation of cellulolytic anaerobic extreme thermophiles from new zealand thermal sites. *Applied and environmental microbiology*, **53**(4), 832-838.
- Sleator, R.D., Hill, C. 2002. Bacterial osmoadaptation: the role of osmolytes in bacterial stress and virulence. *FEMS Microbiology Reviews*, **26**(1), 49-71.
- Stams, A.J.M. 1994. Metabolic interactions between anaerobic bacteria in methanogenic environments. *Antonie van Leeuwenhoek*, **66**(1), 271-294.
- Steinbusch, K.J.J., Hamelers, H.V.M., Plugge, C.M., Buisman, C.J.N. 2011. Biological formation of caproate and caprylate from acetate: fuel and chemical production from low grade biomass. *Energy & Environmental Science*, **4**(1), 216-224.
- Sun, Y., Cheng, J. 2002. Hydrolysis of lignocellulosic materials for ethanol production: a review. *Bioresource Technology*, **83**(1), 1-11.
- Swain, M.R., Krishnan, C. 2015. Improved conversion of rice straw to ethanol and xylitol by combination of moderate temperature ammonia pretreatment and sequential fermentation using *Candida tropicalis*. *Industrial Crops and Products*, **77**, 1039-1046.
- Svensson, B.H., Dubourguier, H.-C., Prensier, G., Zehnder, A.J.B. 1992. *Clostridium quinii* sp. nov., a new saccharolytic anaerobic bacterium isolated from granular sludge. *Archives of Microbiology*, **157**(2), 97-103.
- Taherzadeh, M.J., Karimi, K. 2008. Pretreatment of lignocellulosic wastes to improve ethanol and biogas production: a review. *International journal of molecular sciences*, **9**(9), 1621-1651.
- Talluri, S., Raj, S.M., Christopher, L.P. 2013. Consolidated bioprocessing of untreated switchgrass to hydrogen by the extreme thermophile *Caldicellulosiruptor saccharolyticus* DSM 8903. *Bioresource Technology*, **139**, 272-279.

- Tamagnini, P., Leitão, E., Oliveira, P., Ferreira, D., Pinto, F., Harris, D.J., Heidorn, T., Lindblad, P. 2007. Cyanobacterial hydrogenases: diversity, regulation and applications. *FEMS Microbiology Reviews*, **31**(6), 692-720.
- Tao, Y., Chen, Y., Wu, Y., He, Y., Zhou, Z. 2007. High hydrogen yield from a two-step process of dark- and photo-fermentation of sucrose. *International Journal of Hydrogen Energy*, **32**(2), 200-206.
- Taya, M., Hinoki, H., Yagi, T., Kobayashi, T. 1988. Isolation and characterization of an extremely thermophilic, cellulolytic, anaerobic bacterium. *Applied Microbiology and Biotechnology*, **29**(5), 474-479.
- Thauer, R.K., Jungermann, K., Decker, K. 1977. Energy conservation in chemotrophic anaerobic bacteria. *Bacteriological reviews*, **41**(1), 100-180.
- Tomei, J., Helliwell, R. 2016. Food versus fuel? Going beyond biofuels. *Land Use Policy*, **56**, 320-326.
- United Nations. 2018. Climate Change, United Nations.
- Urbaniec, K., Grabarczyk, R. 2014. Hydrogen production from sugar beet molasses – a techno-economic study. *Journal of Cleaner Production*, **65**, 324-329.
- Uyar, B., Eroglu, I., Yücel, M., Gündüz, U. 2009. Photofermentative hydrogen production from volatile fatty acids present in dark fermentation effluents. *International Journal of Hydrogen Energy*, **34**(10), 4517-4523.
- van de Werken, H.J.G., Verhaart, M.R.A., VanFossen, A.L., Willquist, K., Lewis, D.L., Nichols, J.D., Goorissen, H.P., Mongodin, E.F., Nelson, K.E., van Niel, E.W.J., Stams, A.J.M., Ward, D.E., de Vos, W.M., van der Oost, J., Kelly, R.M., Kengen, S.W.M. 2008. Hydrogenomics of the Extremely Thermophilic Bacterium *Caldicellulosiruptor saccharolyticus*. *Applied and Environmental Microbiology*, **74**(21), 6720-6729.
- van Groenestijn, J.W., Geelhoed, J.S., Goorissen, H.P., Meesters, K.P.M., Stams, A.J.M., Claassen, P.A.M. 2009. Performance and population analysis of a non-sterile trickle bed reactor inoculated with *Caldicellulosiruptor saccharolyticus*, a thermophilic hydrogen producer. *Biotechnology and Bioengineering*, **102**(5), 1361-1367.
- van Groenestijn, J.W., Hazewinkel, J.H.O., Nienoord, M., Bussmann, P.J.T. 2002. Energy aspects of biological hydrogen production in high rate bioreactors operated in the thermophilic temperature range. *International Journal of Hydrogen Energy*, **27**.
- Van Loosdrecht, M.C.M., Heijnen, S.J. 1993. Biofilm bioreactors for waste-water treatment. *Trends in Biotechnology*, **11**(4), 117-121.
- van Niel, E.W.J., Budde, M.A.W., de Haas, G.G., van der Wal, F.J., Claassen, P.A.M., Stams, A.J.M. 2002. Distinctive properties of high hydrogen producing extreme thermophiles, *Caldicellulosiruptor saccharolyticus* and *Thermotoga elfii*. *International Journal of Hydrogen Energy*, **27**(11), 1391-1398.
- van Niel, E.W.J., Claassen, P.A.M., Stams, A.J.M. 2003. Substrate and product inhibition of hydrogen production by the extreme thermophile, *Caldicellulosiruptor saccharolyticus*. *Biotechnol Bioeng*, **81**.
- VanFossen, A.L., Ozdemir, I., Zelin, S.L., Kelly, R.M. 2011. Glycoside hydrolase inventory drives plant polysaccharide deconstruction by the extremely thermophilic bacterium *Caldicellulosiruptor saccharolyticus*. *Biotechnology and Bioengineering*, **108**(7), 1559-1569.

- VanFossen, A.L., Verhaart, M.R.A., Kengen, S.M.W., Kelly, R.M. 2009. Carbohydrate Utilization Patterns for the Extremely Thermophilic Bacterium *Caldicellulosiruptor saccharolyticus* Reveal Broad Growth Substrate Preferences. *Applied and Environmental Microbiology*, **75**(24), 7718-7724.
- Wang, C., Zhang, H., Cai, H., Zhou, Z., Chen, Y., Chen, Y., Ouyang, P. 2014. Succinic Acid Production from Corn Cob Hydrolysates by Genetically Engineered *Corynebacterium glutamicum*. *Applied Biochemistry and Biotechnology*, **172**(1), 340-350.
- Wang, J., Wan, W. 2009. Factors influencing fermentative hydrogen production: A review. *International Journal of Hydrogen Energy*, **34**(2), 799-811.
- Wang, J., Yu, J. 2001. Kinetic analysis on formation of poly(3-hydroxybutyrate) from acetic acid by *Ralstonia eutropha* under chemically defined conditions. *Journal of Industrial Microbiology and Biotechnology*, **26**(3), 121-126.
- Vargas, S.R., Santos, P.V.d., Giraldi, L.A., Zaiat, M., Calijuri, M.d.C. 2018. Anaerobic phototrophic processes of hydrogen production by different strains of microalgae *Chlamydomonas* sp. *FEMS Microbiology Letters*, **365**(9), fny073-fny073.
- Weissman, J.C., Benemann, J.R. 1977. Hydrogen production by nitrogen-starved cultures of *Anabaena cylindrica*. *Applied and environmental microbiology*, **33**(1), 123-131.
- Venkata Mohan, S., Nikhil, G.N., Chiranjeevi, P., Nagendranatha Reddy, C., Rohit, M.V., Kumar, A.N., Sarkar, O. 2016. Waste biorefinery models towards sustainable circular bioeconomy: Critical review and future perspectives. *Bioresource Technology*, **215**, 2-12.
- Vennestrøm, P.N.R., Osmundsen, C.M., Christensen, C.H., Taarning, E. 2011. Beyond Petrochemicals: The Renewable Chemicals Industry. *Angewandte Chemie International Edition*, **50**(45), 10502-10509.
- Verhaart, M.R.A., Bielen, A.A.M., Oost, J.v.d., Stams, A.J.M., Kengen, S.W.M. 2010. Hydrogen production by hyperthermophilic and extremely thermophilic bacteria and archaea: mechanisms for reductant disposal. *Environmental Technology*, **31**(8-9), 993-1003.
- Vignais, P.M., Billoud, B. 2007. Occurrence, Classification, and Biological Function of Hydrogenases: An Overview. *Chemical Reviews*, **107**(10), 4206-4272.
- Vignais, P.M., Billoud, B., Meyer, J. 2001. Classification and phylogeny of hydrogenases1. *FEMS Microbiology Reviews*, **25**(4), 455-501.
- Willquist, K., Claassen, P.A.M., van Niel, E.W.J. 2009. Evaluation of the influence of CO₂ on hydrogen production by *Caldicellulosiruptor saccharolyticus*. *International Journal of Hydrogen Energy*, **34**(11), 4718-4726.
- Willquist, K., Nkemka, V.N., Svensson, H., Pawar, S., Ljunggren, M., Karlsson, H., Murto, M., Hultberg, C., van Niel, E.W.J., Liden, G. 2012. Design of a novel biohythane process with high H₂ and CH₄ production rates. *International Journal of Hydrogen Energy*, **37**(23), 17749-17762.
- Willquist, K., Pawar, S.S., Niel, E.W.J. 2011. Reassessment of hydrogen tolerance in *Caldicellulosiruptor saccharolyticus*. *Microbial Cell Factories*, **10**.
- Willquist, K., van Niel, E.W.J. 2012. Growth and hydrogen production characteristics of *Caldicellulosiruptor saccharolyticus* on chemically defined minimal media. *International Journal of Hydrogen Energy*, **37**(6), 4925-4929.

- Willquist, K., van Niel, E.W.J. 2010. Lactate formation in *Caldicellulosiruptor saccharolyticus* is regulated by the energy carriers pyrophosphate and ATP. *Metab Eng*, **12**.
- Willquist, K., Zeidan, A.A., van Niel, E.W.J. 2010. Physiological characteristics of the extreme thermophile *Caldicellulosiruptor saccharolyticus*: an efficient hydrogen cell factory. *Microbial Cell Factories*, **9**, 89-89.
- Wolin, E.A., Wolin, M.J., Wolfe, R.S. 1963. Formation of Methane by Bacterial Extracts. *Journal of Biological Chemistry*, **238**(8), 2882-2886.
- Wyman, C.E. 1994. Ethanol from lignocellulosic biomass: Technology, economics, and opportunities. *Bioresource Technology*, **50**(1), 3-15.
- Xu, Q., Li, S., Fu, Y., Tai, C., Huang, H. 2010. Two-stage utilization of corn straw by *Rhizopus oryzae* for fumaric acid production. *Bioresource Technology*, **101**(15), 6262-6264.
- Yang, S.-J., Kataeva, I., Hamilton-Brehm, S.D., Engle, N.L., Tschaplinski, T.J., Doepcke, C., Davis, M., Westpheling, J., Adams, M.W.W. 2009. Efficient degradation of lignocellulosic plant biomass, without pretreatment, by the thermophilic anaerobe "*Anaerocellum thermophilum*" DSM 6725. *Applied and environmental microbiology*, **75**(14), 4762-4769.
- Yang, S.-J., Kataeva, I., Wiegel, J., Yin, Y., Dam, P., Xu, Y., Westpheling, J., Adams, M.W.W. 2010. Classification of '*Anaerocellum thermophilum*' strain DSM 6725 as *Caldicellulosiruptor bescii* sp. nov. *International Journal of Systematic and Evolutionary Microbiology*, **60**(9), 2011-2015.
- Ying, Y., Meng, D., Chen, X., Li, F. 2013. An extremely thermophilic anaerobic bacterium *Caldicellulosiruptor* sp. F32 exhibits distinctive properties in growth and xylanases during xylan hydrolysis. *Enzyme and Microbial Technology*, **53**(3), 194-199.
- Yokoi, H., Tokushige, T., Hirose, J., Hayashi, S., Takasaki, Y. 1998. H₂ production from starch by a mixed culture of *Clostridium butyricum* and *Enterobacter aerogenes*. *Biotechnology Letters*, **20**(2), 143-147.
- Young, J., Chung, D., Bomble, Y.J., Himmel, M.E., Westpheling, J. 2014. Deletion of *Caldicellulosiruptor bescii* CelA reveals its crucial role in the deconstruction of lignocellulosic biomass. *Biotechnology for Biofuels*, **7**(1), 142.
- Zehnder, A.J., Brock, T.D. 1979. Methane formation and methane oxidation by methanogenic bacteria. *Journal of bacteriology*, **137**(1), 420-432.
- Zeidan, A., Rådström, P., Niel, E. 2010. Stable coexistence of two *Caldicellulosiruptor* species in a de novo constructed hydrogen-producing co-culture. *Microbial Cell Factories*, **9**.
- Zeidan, A.A., Van Niel, E.W.J. 2009. Developing a thermophilic hydrogen-producing co-culture for efficient utilization of mixed sugars. *International Journal of Hydrogen Energy*, **34**(10), 4524-4528.
- Zeidan, A.A., van Niel, E.W.J. 2010. A quantitative analysis of hydrogen production efficiency of the extreme thermophile *Caldicellulosiruptor owensensis* OLT. *International Journal of Hydrogen Energy*, **35**(3), 1128-1137.
- Zeikus, J.G. 1977. The biology of methanogenic bacteria. *Bacteriological reviews*, **41**(2), 514-541.

- Zhang, Y., Zhang, F., Chen, M., Chu, P.-N., Ding, J., Zeng, R.J. 2013. Hydrogen supersaturation in extreme-thermophilic (70°C) mixed culture fermentation. *Applied Energy*, **109**, 213-219.
- Zhang, Z.-P., Show, K.-Y., Tay, J.-H., Liang, D.T., Lee, D.-J. 2008. Enhanced Continuous Biohydrogen Production by Immobilized Anaerobic Microflora. *Energy & Fuels*, **22**(1), 87-92.
- Zurawski, J.V., Conway, J.M., Lee, L.L., Simpson, H.J., Izquierdo, J.A., Blumer-Schuette, S., Nookaew, I., Adams, M.W.W., Kelly, R.M. 2015. Comparative Analysis of Extremely Thermophilic *Caldicellulosiruptor* Species Reveals Common and Unique Cellular Strategies for Plant Biomass Utilization. *Applied and Environmental Microbiology*, **81**(20), 7159-7170.
- Zuroff, T.R., Curtis, W.R. 2012. Developing symbiotic consortia for lignocellulosic biofuel production. *Applied Microbiology and Biotechnology*, **93**(4), 1423-1435.
- Özgür, E., Afsar, N., de Vrije, T., Yücel, M., Gündüz, U., Claassen, P.A.M., Eroglu, I. 2010a. Potential use of thermophilic dark fermentation effluents in photofermentative hydrogen production by *Rhodobacter capsulatus*. *Journal of Cleaner Production*, **18**, S23-S28.
- Özgür, E., Mars, A.E., Peksel, B., Louwse, A., Yücel, M., Gündüz, U., Claassen, P.A.M., Eroğlu, İ. 2010b. Biohydrogen production from beet molasses by sequential dark and photofermentation. *International Journal of Hydrogen Energy*, **35**(2), 511-517.

Hydrogen, the number one element on the periodic table

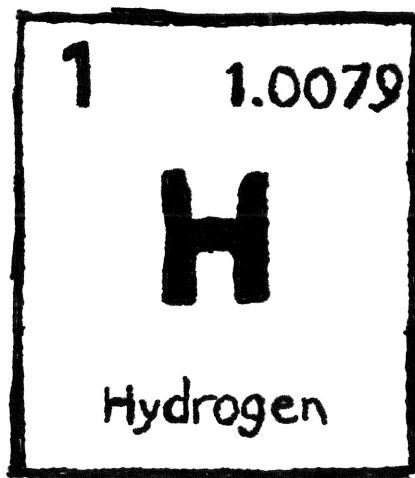

International Year of the Periodic Table, 2019