



# LUND UNIVERSITY

## Modelling and Simulation of the Fifth-Generation District Heating and Cooling

Abugabbara, Marwan

2021

*Document Version:*

Publisher's PDF, also known as Version of record

[Link to publication](#)

*Citation for published version (APA):*

Abugabbara, M. (2021). *Modelling and Simulation of the Fifth-Generation District Heating and Cooling*. [Licentiate Thesis, Division of Building Services]. Division of Building Services, LTH, Lund University.

*Total number of authors:*

1

### General rights

Unless other specific re-use rights are stated the following general rights apply:

Copyright and moral rights for the publications made accessible in the public portal are retained by the authors and/or other copyright owners and it is a condition of accessing publications that users recognise and abide by the legal requirements associated with these rights.

- Users may download and print one copy of any publication from the public portal for the purpose of private study or research.
- You may not further distribute the material or use it for any profit-making activity or commercial gain
- You may freely distribute the URL identifying the publication in the public portal

Read more about Creative commons licenses: <https://creativecommons.org/licenses/>

### Take down policy

If you believe that this document breaches copyright please contact us providing details, and we will remove access to the work immediately and investigate your claim.

LUND UNIVERSITY

PO Box 117  
221 00 Lund  
+46 46-222 00 00

# Modelling and Simulation of the Fifth-Generation District Heating and Cooling

MARWAN ABUGABBARA

FACULTY OF ENGINEERING | LUND UNIVERSITY

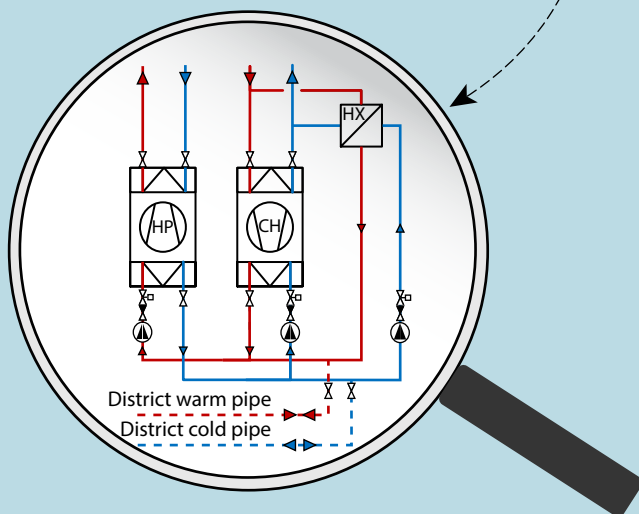
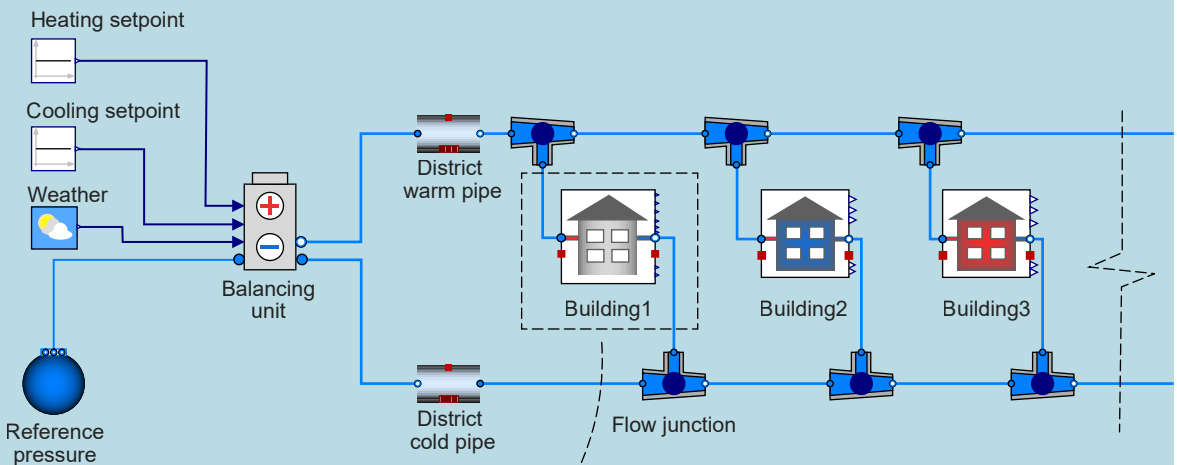





# Modelling and Simulation of the Fifth- Generation District Heating and Cooling

Marwan Abugabbara



**LUND**  
UNIVERSITY

LICENTIATE DISSERTATION

by due permission of the Faculty of Engineering, Lund University, Sweden.  
To be defended at lecture hall V:C, building V-huset, John Ericssons väg 1,  
Lund on 11 June 2021 at 13:00.

*Faculty opponent*

Peter Sorknæs

Associate Professor, Department of Planning  
Aalborg University, Denmark

<b>Organization</b> LUND UNIVERSITY Faculty of Engineering Department of Building and Environmental Technology Division of Building Services  <b>Author</b> Marwan Abugabbara	<b>Document name</b> LICENTATE DISSERTATION	
	<b>Date of issue</b> 2021-05-11	
	<b>Sponsoring organizations</b> See acknowledgments section	
<b>Title and subtitle</b> Modelling and Simulation of the Fifth-Generation District Heating and Cooling		
<b>Abstract</b> District heating and cooling are efficient systems for distributing heat and cold in urban areas. They are a key solution for planning future urban energy-efficient systems due to their high potential for integrating renewable energy sources. The systems also play an important role in community resilience, which makes them a multidisciplinary research topic. The continuous development of these systems has now reached the fifth-generation whereby end-customers can benefit from the intrinsic synergies this generation offers. A typical Fifth-Generation District Heating and Cooling (5GDHC) system consists of connected buildings that together have simultaneous heating and cooling demands. Local heat pumps and chillers in decentralised substations modulate the low network temperature to the desired building supply temperatures. The demands are potentially balanced by the means of recovering local waste heat from chillers, while also utilising heat pumps to provide direct cooling. The heat carrier fluid in the distribution pipes can therefore flow in either direction in the so-called bidirectional low-temperature network. A balancing unit is incorporated to compensate for network energy imbalances. The exchange of energy flows is realised at different stages within the individual building and across connected buildings. Numerous factors influence the quantity and quality of the exchanged energy flows. Demand profiles in each building, the efficiency of building energy systems, and control logics of system components are some examples of these factors. Investigating this generation using traditional computational tools developed using imperative programming languages is no longer suitable due to system complexity, size variability, and changes adopted in different use cases. Modelica is a free open-source equation-based object-oriented language used for the modelling and simulation of multi-domain physical systems. Models are described by differential-algebraic and discrete equations. The mathematical relations between model variables are encapsulated inside an icon that represents the model. Different component models interface variables through standardised interfaces and connection lines. Large complex systems are composed by the visual assembly of components in a Lego-like approach. Models developed in Modelica can be easily inherited for rapid virtual prototyping and/or edited to adopt changes in the model use. This dissertation has a fourfold objective. Firstly, it demonstrates the development of a simulation model for an installed 5GDHC system located in Lund, Sweden. Secondly, it characterises the components that constitute a 5GDHC system. Thirdly, it unravels the exchange of energy flows at different system levels and describes, in a logical progression, the modelling of 5GDHC with Modelica. Fourthly, it presents ethical risk analyses of the different role-combinations that may arise in 5GDHC business models. The developed model is used in performing annual simulations and to evaluate the system performance under two different substation design cases. The results indicate that adding a direct cooling heat exchanger in each substation can reduce the electric energy consumption at both substation and system levels by about 10 and 7 %, respectively. Moreover, the annual waste heat to ambient air can be decreased by about 17 %. The dissertation fosters an ethical discourse that engages the public and all who take part in the multidisciplinary research on 5GDHC to guarantee safe operation and appropriate services. Future research will build on the models presented in this dissertation to investigate different network temperature and pressure control strategies, in addition to adopting several design concepts for balancing units and thermal energy storage systems.		
<b>Key words</b> Waste heat recovery; Heat pumps; 5GDHC; Modelica; Ethical risk analyses		
<b>ISRN</b> LUTVDG/TVIT-21/1004-SE(138)		<b>Language</b> English
<b>ISSN</b> 1652-6783		<b>ISBN</b> 978-91-85415-14-4 (printed) <b>ISBN</b> 978-91-85415-15-1 (e-published)
Recipient's notes	<b>Number of pages</b> 138	Price
	Security classification	

I, the undersigned, being the copyright owner of the abstract of the above-mentioned dissertation, hereby grant to all reference sources permission to publish and disseminate the abstract of the above-mentioned dissertation.

Signature



Date 2021-05-11

# Modelling and Simulation of the Fifth- Generation District Heating and Cooling

Marwan Abugabbara



**LUND**  
UNIVERSITY

Cover illustration by Marwan Abugabbara

© copyright pp 1-78 Marwan Abugabbara  
Paper 1 © The Authors (Open access)  
Paper 2 © The Authors (Open access)  
Paper 3 © The Authors (Submitted manuscript)

Lund University, Faculty of Engineering  
Department of Building and Environmental Technology  
Division of Building Services  
SE-221 00 Lund  
Sweden

ISBN 978-91-85415-14-4 (printed)  
ISBN 978-91-85415-15-1 (e-published)  
ISRN LUTVDG/TVIT-21/1004-SE(138)  
ISSN 1652-6783

Printed in Sweden by Media-Tryck, Lund University  
Lund 2021



Media-Tryck is a Nordic Swan Ecolabel  
certified provider of printed material.  
Read more about our environmental  
work at [www.mediatryck.lu.se](http://www.mediatryck.lu.se)

**MADE IN SWEDEN** 



*To my mother,*

*Maisa Farrag  
(1954 - 2013)*

*To my father,*

*Yakoub Abujbara  
(1946 - 1999)*



“The psyche is the greatest of all cosmic wonders and the *sine qua non* of the world as an object. [...] Swamped by the knowledge of external objects, the subject of all knowledge has been temporarily eclipsed to the point of seeming non-existence.”

– Carl Jung, *The Spirit of Psychology*



# Acknowledgments

A research project is a fruitful collaboration between many individuals and organisations. I would like to take this opportunity to acknowledge the impact the following individuals and organisations have had on this research.

## Institutional

The work behind this research was carried out at the Division of Building Services, Department of Building and Environmental Technology, Faculty of Engineering, Lund University. I would like to begin by thanking my supervisors for their involvement during the past two years. To my main supervisor Dennis Johansson for making my research environment conducive to concentrated and productive work. I have learned a great deal from Dennis about the management and coordination of research projects by observing his work methods. To my assistant supervisor Saqib Javed for providing me with invaluable feedback that has greatly influenced my academic development. Saqib gives multiple rounds of critical feedback on every single written word, which is an incredible asset for any PhD student at the beginning of their academic career. To my assistant supervisor Hans Bagge for the comments and advice especially on the writing about engineering ethics.

I would like to extend my thanks to my colleague Jonas Lindhe for kindly sharing the spreadsheet he has developed for sizing fifth-generation district heating and cooling systems. I consider that spreadsheet as the first reference that revealed to me much about the principles of these systems. Thanks to all my fellow PhD students at Building Services and Building Physics for generously imparting knowledge during the frequent PhD student meetings.

I would like to thank Bitte Rosencrantz for inviting me to join the department JäLM group that promotes equality and diversity. Promoting equal opportunities and autonomous diversity will continue to occupy the heart of discovering innovative solutions for global problems.

## Technical

Modelling of fifth-generation district heating and cooling with Modelica was possible thanks to inheriting and reusing existing component models from the Modelica *Buildings* library. I would like to thank Michael Wetter for developing the free open-source Modelica *Buildings* library which supports model-based research on building and community energy systems.

All the figures presented in this dissertation were produced as scalable vector graphics. The colours in most of these graphics were adjusted to include a wider audience with different forms of colour vision deficiency. It was possible to imagine how it looks like to have a colour vision deficiency thanks to the developers of the online Color BLIndness Simulator.

## Financial

This research was financially supported by the following organisations: the Swedish Energy Agency (Energimyndigheten) under grant number 45952-1; E.ON Sverige AB; Danfoss Värmepumpar AB; Enertech AB; Lambertsson Sverige AB; NIBE Industrier AB; Quantum Energi AB; and SKVP Info & Service AB. The research was partially funded by the European Regional Development Fund, program Interreg Öresund-Kattegat-Skagerrak, project COOLGEOHEAT. I would like to thank these organisations for their generous contribution.

## Personal

I owe much to Nils and Sofia Bergendal for their kindness, understanding, and tremendous support in adversity.

Special thanks go to Kali Olsson for infinite patience and encouragement throughout the writing of this dissertation.

Lund, 1 May 2021

Marwan Abugabbara

# Contents

<b>Acknowledgments</b>	<b>i</b>
<b>Contents</b>	<b>iii</b>
<b>Abstract</b>	<b>v</b>
<b>Sammanfattning</b>	<b>vii</b>
<b>الْمَلَأَصْرُ الْعِلْمِيَّة</b>	<b>ix</b>
<b>Nomenclature</b>	<b>xi</b>
<b>List of Papers</b>	<b>xiii</b>
<b>Summary of Included Papers</b>	<b>xv</b>
<b>1 Introduction</b>	<b>1</b>
1.1 Energy outlook	1
1.2 Energy and climate policies	4
1.3 Background of district heating and cooling	5
1.3.1 Evolution of district heating and cooling	5
1.3.2 Benefits and drawbacks	7
1.4 District heating and cooling markets	8
1.5 Objectives of the dissertation	9
1.6 Research method and limitations	10
1.7 Deliberation about engineering ethics	12
1.8 Overview of the dissertation	13
<b>2 Model-Based System Engineering</b>	<b>15</b>
2.1 The concept of modelling and simulation	16
2.2 Computational tools for modelling district heating and cooling	17
2.3 Modelling of district heating and cooling with Modelica	18
2.4 Modelica simulation environments	19
2.5 Best practice	20
<b>3 System Architecture</b>	<b>21</b>
3.1 System components	21
3.2 Substation operating modes	23
3.2.1 Only heating mode	26

3.2.2	Only cooling mode	27
3.2.3	Dominant heating mode	28
3.2.4	Dominant cooling mode	29
<b>4</b>	<b>Models for System Analyses</b>	<b>31</b>
4.1	Fluid ports	31
4.2	Model for heat pumps	32
4.3	Model for circulation pumps	36
4.4	Model for direct cooling heat exchangers	37
4.5	Model for decentralised substations	38
4.6	Model for balancing unit	39
4.7	Model for 5GDHC district systems	41
<b>5</b>	<b>Case Study</b>	<b>43</b>
5.1	Classification of buildings	43
5.2	Acquisition of heat meter data	45
5.3	Assessment of building clusters	47
5.4	Simulation cases	48
5.5	Assumptions and design parameters	50
<b>6</b>	<b>Case Results and Discussion</b>	<b>51</b>
6.1	Rapid prototyping of models developed in Modelica	51
6.2	Cluster demand profiles	52
6.3	Substation performance	53
6.4	Balancing unit performance	55
6.5	Network temperature oscillation	56
6.6	District supply-demand structure	58
6.7	Sensitivity analyses	60
6.8	Simulation performance	62
6.9	Ethical risk analyses	62
<b>7</b>	<b>Conclusions and Future Research</b>	<b>67</b>
7.1	Conclusions	67
7.2	Future research	68
7.2.1	Model calibration and empirical validation	68
7.2.2	Templates for balancing units	69
7.2.3	Network temperature and pressure control strategies	69
	<b>References</b>	<b>71</b>
	<b>Paper I</b>	<b>79</b>
	<b>Paper II</b>	<b>93</b>
	<b>Paper III</b>	<b>103</b>



# Abstract

District heating and cooling are efficient systems for distributing heat and cold in urban areas. They are a key solution for planning future urban energy-efficient systems due to their high potential for integrating renewable energy sources. The systems also play an important role in community resilience, which makes them a multidisciplinary research topic. The continuous development of these systems has now reached the fifth-generation whereby end-customers can benefit from the intrinsic synergies this generation offers.

A typical Fifth-Generation District Heating and Cooling (5GDHC) system consists of connected buildings that together have simultaneous heating and cooling demands. Local heat pumps and chillers in decentralised substations modulate the low network temperature to the desired building supply temperatures. The demands are potentially balanced by the means of recovering local waste heat from chillers, while also utilising heat pumps to provide direct cooling. The heat carrier fluid in the distribution pipes can therefore flow in either direction in the so-called bidirectional low-temperature network. A balancing unit is incorporated to compensate for network energy imbalances.

The exchange of energy flows is realised at different stages within the individual building and across connected buildings. Numerous factors influence the quantity and quality of the exchanged energy flows. Demand profiles in each building, the efficiency of building energy systems, and control logics of system components are some examples of these factors. Investigating this generation using traditional computational tools developed using imperative programming languages is no longer suitable due to system complexity, size variability, and changes adopted in different use cases.

Modelica is a free open-source equation-based object-oriented language used for the modelling and simulation of multi-domain physical systems. Models are described by differential-algebraic and discrete equations. The mathematical relations between model variables are encapsulated inside an

icon that represents the model. Different component models interface variables through standardised interfaces and connection lines. Large complex systems are composed by the visual assembly of components in a Lego-like approach. Models developed in Modelica can be easily inherited for rapid virtual prototyping and/or edited to adopt changes in the model use.

This dissertation has a fourfold objective. Firstly, it demonstrates the development of a simulation model for an installed 5GDHC system located in Lund, Sweden. Secondly, it characterises the components that constitute a 5GDHC system. Thirdly, it unravels the exchange of energy flows at different system levels and describes, in a logical progression, the modelling of 5GDHC with Modelica. Fourthly, it presents ethical risk analyses of the different role-combinations that may arise in 5GDHC business models. The developed model is used in performing annual simulations and to evaluate the system performance under two different substation design cases.

The results indicate that adding a direct cooling heat exchanger in each substation can reduce the electric energy consumption at both substation and system levels by about 10 and 7 %, respectively. Moreover, the annual waste heat to ambient air can be decreased by about 17 %. The dissertation fosters an ethical discourse that engages the public and all who take part in the multidisciplinary research on 5GDHC to guarantee safe operation and appropriate services. Future research will build on the models presented in this dissertation to investigate different network temperature and pressure control strategies, in addition to adopting several design concepts for balancing units and thermal energy storage systems.

# Sammanfattning

Fjärrvärme och fjärrkyla är ändamålsenliga system för distribution av värme och kyla i tätbebyggda områden. Dessa system är viktiga vid planeringen av framtida energieffektiva system på grund av deras höga potential för att integrera förnybara energikällor. Systemen spelar också en viktig roll i samhällets energiförsörjningssäkerhet, vilket gör dem till ett tvärvetenskapligt forskningsområde. Den kontinuerliga utvecklingen av dessa system har nu nått sin, som man uttrycker det, femte generation där slutkunder kan dra nytta av de inneboende synergier som denna generation erbjuder.

Ett typiskt femte generations fjärrvärme- och kylsystem (5GDHC) består av anslutna byggnader som tillsammans har samtidigt värme- och kylbehov. Lokala värmepumpar och kylmaskiner i decentraliserade undercentraler använder den låga nättemperaturen för att förse byggnaderna med nödvändig temperatur. Energibehovet balanseras genom att återvinna lokal spillvärme från kylmaskiner, samtidigt som man använder värmepumpar för direkt kylning. Värmebärandevätskan i distributionsrören kan därför strömma i båda riktningarna i det så kallade dubbelriktade lågtemperaturnätet. En balanseringsenhet införs för att kompensera för energiobalanser i nätet.

Utbytet av effekt sker i olika delsystem inom den enskilda byggnaden och också mellan anslutna byggnader. Många faktorer påverkar kvantiteten och kvaliteten på de utbytta effekterna. Behovsprofiler i varje byggnad, effektiviteten i byggnadens energisystem och reglerinställningar för systemkomponenter är några exempel på dessa faktorer. Att undersöka femte generationens fjärrvärme och fjärrkyla med traditionella beräkningsverktyg som utvecklats med konventionella programmeringsspråk är inte längre lämpligt på grund av systemkomplexitet, storleksvariation och variationer som uppstår i olika användningsfall.

Modelica är ett gratis ekvationbaserat objektorienterat språk baserat på öppen källkod. Modelicavaldes för modellering och simulering av fysiska

system med flera domäner. Modeller beskrivs med differentialalgebraiska ekvationer och diskreta ekvationer. De matematiska förhållandena mellan modellvariabler är inkapslade i en ikon som representerar modellen. Olika komponentmodeller har standardiserade gränssnitt till andra komponentmodeller. Stora komplexa system består av en visuell sammansättningen av komponenter på ett Lego-liknande tillvägagångssätt. Modeller som utvecklats i Modelica kan enkelt ärvas för snabba virtuella prototypbyggen eller redigeras om förändringar i modellen behövs.

Denna licentiatavhandling har ett fyra mål. För det första beskrivs utvecklingen av en simuleringsmodell för ett installerat 5GDHC-system i Lund, Sverige. För det andra karakteriseras komponenterna som utgör ett 5GDHC-system. För det tredje beskrivs utbytet av energiförflyttningar på olika systemnivåer och visas utvecklingen av modelleringen av 5GDHC med Modelica. För det fjärde presenteras etiska riskanalyser av de olika aktörsrollskombinationerna som kan uppstå i 5GDHC-affärsmodeller. Den utvecklade modellen används för att utföra årliga simuleringar och för att utvärdera systemets prestanda under två olika fall av undercentraler.

Resultaten indikerar att tillsats av en direktkylningsvärmexlare i varje undercentral kan minska den elanvändningen vid både undercentralen och i hela systemet med cirka 10 respektive 7 %. Dessutom kan den årliga spillvärmens till omgivande luft minska med cirka 17%. Avhandlingen främjar en etisk diskurs som engagerar allmänheten och alla som deltar i den tvärvetenskapliga forskningen om 5GDHC för att garantera säker drift och lämpliga tjänster. Framtida forskning kommer att bygga på modellerna som presenteras i denna avhandling för att undersöka olika nättertemperatur- och tryckregleringsstrategier, förutom att testa fler konstruktionerslösningar för balanseringsenheter och lagringssystem för termisk energi.

# الْمَلَخَصُ الْعِلْمِيُّ

شَبَكَاتُ تَدْفِئَةٍ وَتَبْرِيدِ الْمَبْنِيِّ هِيَ نُظْمٌ فَعَالَةٌ لِتَوْزِيعِ الْأَحْمَالِ الْحَرَارِيَّةِ الْأَازِمَةِ لِتَدْفِئَةٍ وَتَبْرِيدِ الْمَبْنِيِّ فِي الْمَنَاطِقِ الْحَضَرِيَّةِ الْمَكْتَنَّةِ بِالسَّكَّانِ. نَظَرًا لِإِمْكَانِيَّاتِهَا الْعَالِيَةِ فِي دَمَجِ مَصَادِرِ الطَّاقَةِ الْمُتَجَدِّدَةِ، تُشَكِّلُ هَذِهِ الشَّبَكَاتُ حَلًّا رَئِيسِيًّا فِي التَّخْطِيطِ لِأَنْظِمَةِ حَضَرِيَّةٍ مُسْتَقْبَلِيَّةٍ مُوقِرَةٍ لِلطَّاقَةِ. كَمَا تَلْعَبُ أَيْضًا دَوْرًا هَامًا فِي مُرُونَةِ الْمُجْتَمَعِ، مِمَّا يَجْعَلُهَا مَوْضُوعَ بَحْثٍ مُتَعَدِّدِ التَّخْصُّصَاتِ. التَّطْوِيرُ الْمُسْتَمْتِرُ لِهَذِهِ الشَّبَكَاتِ وَصَلَ الْآنَ إِلَى الْجِيلِ الْخَامِسِ حَيْثُ يُمَكِّنُ لِلْعَمَلَاءِ الْمُتَّصِلِينَ بِنَفْسِ الشَّبَكَةِ الْإِسْتِفَادَةَ مِنَ التَّأَثُّرِ الْجَوْهَرِيِّ الَّذِي يَقْدَمُهُ هَذَا الْجِيلُ.

تَتَكَوَّنُ شَبَكَاتُ التَّدْفِئَةِ وَالتَّبْرِيدِ مِنَ الْجِيلِ الْخَامِسِ مِنْ مَبْنِيٍّ مُتَّصِلَةٍ وَالَّتِي تُشَكِّلُ مَعًا مُتَّصَلَاتٍ مُتَرَامِنَةً لِلتَّدْفِئَةِ وَالتَّبْرِيدِ. يُوجَدُ فِي الْحَطَّاتِ الْفَرْعِيَّةِ دَاخِلَ كُلِّ بِنَايَةٍ مَصْخَّاتٌ حَرَارِيَّةٌ وَوَحْدَاتٌ تَبْرِيدٍ تَقُومُ بِتَعْدِيلِ دَرَجَاتِ الْحَرَارَةِ فِي الشَّبَكَةِ إِلَى دَرَجَاتِ الْحَرَارَةِ الْمَطْلُوبِ إِمْدَادُهَا فِي كُلِّ بِنَايَةٍ. الْجِيلُ الْخَامِسُ يَتَّبِعُ إِمْكَانِيَّةَ تَبَادُلٍ وَمُوازِنَةِ الْمُتَّصَلَاتِ الْحَرَارِيَّةِ فِي كُلِّ بِنَايَةٍ وَبَيْنَ كَافَّةِ الْمَبْنِيِّ الْمُتَّصِلَةِ بِنَفْسِ الشَّبَكَةِ. يَتَحَقَّقُ هَذَا التَّبَادُلُ مِنْ خِلَالِ اسْتِزْدَادِ الْحَرَارَةِ الْمُتَّبَعَةِ مِنْ وَحْدَاتِ التَّبْرِيدِ وَالَّتِي عَالِيًا مَا يَمُ هَدْرُهَا، بِالإِضَافَةِ لِاسْتِخْدَامِ الْمِصْخَّاتِ الْحَرَارِيَّةِ لِإِمْدَادِ تَبْرِيدٍ بِشَكْلِ مُبَاشِرٍ دُونَ الْحَاجَةِ لِلْحَمَلِ الْكَهْرِبَائِيِّ الْمَبْدُولِ فِي صَوَاعِظِ الْغَازَاتِ دَاخِلَ وَحْدَاتِ التَّبْرِيدِ. يَنْتُجُ مِنْ عَمَلِيَّةِ الْمُبَادَلَةِ السَّابِقَةِ إِمْكَانِيَّةٌ تَدْفِئُ الْمَائِعِ دَاخِلَ أَنْبِيَبِ التَّوْزِيعِ فِي أَيِّ اتِّجَاهٍ فِي مَا يُطْلَقُ عَلَيْهِ بِ شَبَكَاتِ دَرَجَاتِ الْحَرَارَةِ الْمُنْخَفِضَةِ ثَنَائِيَّةِ الْإِتِّجَاهِ. مِنْ أَجْلِ تَعْوِضِ الْإِحْتِيَاجَاتِ بَيْنَ مُتَّصَلَاتِ الْحَرَارَةِ وَالتَّبْرِيدِ عَبْرَ الشَّبَكَةِ بِكُلِّهَا، يَمُ دَمَجُ وَحْدَةٍ تَوَازُنٍ مَكْمُونٍ أَخِيرٍ لِمُرَكَّبَاتِ شَبَكَاتِ الْجِيلِ الْخَامِسِ.

يَمُ تَحْقِيقُ تَبَادُلِ الطَّاقَةِ الْمُنْدَقَّةِ عَبْرَ مَرَاجِلَ مُخْتَلِفَةٍ دَاخِلِ الْبِنَايَةِ وَبَيْنَ كَافَّةِ الْمَبْنِيِّ الْمُتَّصِلَةِ. الْعَدِيدُ مِنَ الْعَوَامِلِ تُؤَثِّرُ فِي كَيْفِيَّةِ وَنَوْعِيَّةِ الطَّاقَةِ الْمُنْدَقَّةِ وَالْمُبَادَلَةِ. فَعَلَى سَبِيلِ الْمِثَالِ لَا الْحَصْرَ، تُعَدُّ مُتَّصَلَاتُ الطَّاقَةِ فِي كُلِّ بِنَايَةٍ، وَكَهَاءَةُ نُظْمِ الطَّاقَةِ فِي الْمَبْنِيِّ، وَمَعَايِيرُ التَّحَكُّمِ فِي مَكْمُونَاتِ النِّظَامِ مِنْ بَعْضِ تِلْكَ الْعَوَامِلِ. التَّحْقِيقُ وَالبَحْثُ فِي هَذَا الْجِيلِ مِنَ الشَّبَكَاتِ لَمْ يَعُدْ مُنَاسِبًا بِاسْتِخْدَامِ

الأدوات الحاسوبية التقليدية والمطورة باستخدام لغات برمجة مألوفة وذلك بسبب مستوى تعقيد النظام والتغير المعيارى في حجمه والتغيرات التي يتم تبنيها في حالات الاستخدام المختلفة.

موديلكا هي لغة برمجة مجالية مفتوحة المصدر وتعتمد على المعادلات والبرمجة كائنية التوجه وتستخدم في نمذجة ومحاكاة الأنظمة الفيزيائية متعددة المجالات. يتم وصف التماذج في موديلكا بواسطة معادلات تفاضلية جبرية ومعادلات منفصلة. يتم تغليف العلاقات الرياضية بين متغيرات النموذج داخل رمز مرئي يمثل ذلك النموذج. تتبادل التماذج المختلفة المتغيرات في ما بينها من خلال واجهات قياسية موحدة وخطوط اتصال. يتم بناء الأنظمة الفيزيائية المعقدة من خلال تجميع مرئي للتماذج في نهج يشبه بناء مجسمات باستخدام مكعبات الليجو. التماذج المطورة باستخدام موديلكا يمكن أن توارث من أجل تكوين نماذج افتراضية سريعة كما يمكن أيضاً تحرير تلك التماذج لاعتماد تغيرات في حالات استخدام مختلفة.

تهدف هذه الأطروحة لتحقيق أربعة أهداف. أولاً، توضيح كيفية تطوير نموذج محاكاة لنظام من شبكات الجيل الخامس والذي يقع في مدينة لوند في السويد. ثانياً، تمييز المركبات التي تكون شبكات الجيل الخامس لتدفئة وتبريد المباني في المناطق المكتظة بالسكان. ثالثاً، الكشف عن الكيفية التي يتم من خلالها تبادل الطاقة المتدفقة عبر مستويات النظام المختلفة والتوضيح وبأسلوب يتدرج من السهل إلى المعقد الكيفية التي يتم من خلالها نمذجة ومحاكاة شبكات الجيل الخامس باستخدام لغة موديلكا. رابعاً، تقديم تحليل للمخاطر الأخلاقية المحتملة نتيجة الأدوار المختلفة للأفراد والمنظمات والتي قد تنشأ في نماذج الأعمال الجديدة في الجيل الخامس. يُستخدم النموذج المطور في إجراء محاكاة سنوية لتقييم أداء النظام في حالتين مختلفتين من تصميم المحطات الفرعية في كل بنائة.

تشير النتائج إلى أن إضافة مبادل حراري للتبريد المباشر في كل محطة فرعية يمكن أن يقلل من استهلاك الطاقة الكهربائية على مستوى كل من المحطات الفرعية والنظام بحوالي ١٠ و ٧ بالمئة على التوالي. علاوة على ذلك، يمكن تقليل الحرارة المهدرة سنوياً إلى الهواء المحيط بحوالي ١٧ بالمئة. تُعزز هذه الأطروحة الخطاب الأخلاقي الذي يهدف لإشراك الجمهور وكل من يقوم بالبحث في الجيل الخامس من شبكات تدفئة وتبريد المباني في المناطق المكتظة بالسكان لضمان التشغيل الآمن وتقديم الخدمات المناسبة. الأبحاث المستقبلية ستبني على النماذج المقدمة في هذه الأطروحة لتحقيق في استراتيجيات مختلفة للتحكم في هبوط الضغط ودرجات الحرارة في الشبكة بالإضافة لاعتماد العديد من التصاميم لوحدات التوازن وتُلم تخزين الطاقة الحرارية.

# Nomenclature

## Terminology

*District heating and cooling systems, district heating and cooling networks, and district heating and cooling grids:* terms that are used interchangeably throughout the dissertation. It is considered sufficient to use only *district heating and cooling* as an all-encompassing term, such as in the title of the dissertation.

*Bidirectional pipe networks:* thermal pipe networks used to supply heating and cooling and where the flow of the heat carrier can reverse its direction.

*Substation:* a technical room that serves as the link between the district network side and the building demand side. The room consists of technical installations such as heat pumps, chillers, circulation pumps, valves, and domestic distribution pipes.

*Balancing unit:* an external energy system that compensates network energy imbalance due to demand disturbances. It injects heat into the network in case connected buildings have dominant heating demand. It extracts heat from the network when connected buildings have dominant cooling demand, which results in excess waste heat from chillers.

## Latin letters

$T$	Temperature	K
$\dot{Q}$	Heat flow	W
$\dot{V}$	Volume flow rate	m <sup>3</sup> /s
$c_p$	Specific heat capacity	J/kg·K
$\dot{m}$	Mass flow rate	kg/s
$h$	Specific enthalpy	J/kg
$P$	Power	W
$t$	Time	s

$x$  Humidity ratio  $\text{kg}_{\text{water}}/\text{kg}_{\text{air}}$

### Greek letters

$\eta$  Efficiency %  
 $\Delta p$  Pressure difference Pa  
 $\Delta T$  Temperature difference K  
 $\Phi$  Demand Overlap Coefficient –

### Abbreviations

5GDHC Fifth-Generation District Heating and Cooling  
BES Building Energy System  
CHP Combined Heat and Power  
CH Chiller  
COP Coefficient of Performance  
DOC Demand Overlap Coefficient  
HP Heat Pump  
FMI Functional Mock-up Interface  
MBSE Model-Based System Engineering

### Subscripts

b Building  
c Cooling  
comp Compressor  
cond Condenser  
evap Evaporator  
h Heating  
nom Nominal  
ret Return  
w Water

### Mathematical operators, sets and indices

$\forall$  For all elements in a set  
 $\in$  Element of a set  
 $b \in B$  Buildings  
 $t \in \mathcal{T}$  Time steps



# List of Papers

This dissertation is synthesised around the three papers listed below. The papers are appended at the end of the dissertation and will be referred to by their Roman numerals throughout the following chapters.

## **Paper I**

Bibliographic analysis of the recent advancements in modeling and co-simulating the fifth-generation district heating and cooling systems.

Abugabbara, M., Javed, S., Bagge, H., & Johansson, D.

*Energy and Buildings*. Elsevier Ltd. Volume 224, 1 October 2020, 110260

DOI: [10.1016/j.enbuild.2020.110260](https://doi.org/10.1016/j.enbuild.2020.110260)

## **Paper II**

A Novel Method for Designing Fifth-Generation District Heating and Cooling Systems.

Abugabbara, M., & Lindhe, J.

*In Proceedings of The 10th International Cold Climate Conference, 20-21 April 2021, Tallinn, Estonia*

DOI: [10.1051/e3sconf/202124609001](https://doi.org/10.1051/e3sconf/202124609001)

## **Paper III**

Modelica-based simulations of decentralised substations to support decarbonisation of district heating and cooling.

Abugabbara, M., Lindhe, J., Javed, S., Bagge, H., & Johansson, D.

*The 17th International Symposium on District Heating and Cooling, 6-9 September 2021, Nottingham, United Kingdom*

(Submitted manuscript).

My contributions to each paper are presented in the below table:

---

	Conceptualisation	Methodology	Software	Formal analyses	Investigation	Data curation	Writing – original draft	Writing – review & editing	Visualisation
Paper I	3	3	3	3	3	3	3	3	3
Paper II	3	3	3	3	3	3	3	3	3
Paper III	3	3	3	3	3	3	3	3	3
No contribution	0								
Limited contribution	1								
Moderate contribution	2								
Significant contribution	3								

---

# Summary of Included Papers

**Paper I** establishes the foundation of the research project. The paper is in line with the objectives of the International Energy Agency Annex 60 that aims to develop next generation building and community energy grids based on the Modelica language and the Functional Mock-up Interface standard. Several studies that have reported successful use of Modelica and FMI in modelling and co-simulating district heating and cooling systems are reviewed. Bibliographic maps are presented to link the literature based on different bibliometrics. Control strategies for fifth-generation district heating and cooling and simulation performance of district energy systems in Modelica are discussed.

**Paper II** demonstrates a design method for sizing the main components in a fifth-generation district heating and cooling system. Quantification of the exchanged energy flows between connected buildings is presented through three different stages. The paper explores the possibility of integrating fifth-generation district heating and cooling system into existing buildings. Detailed assessment of building clusters is also provided.

**Paper III** investigates two different design cases for decentralised substations. The paper main contribution is the analyses of substation energy systems performance before and after the implementation of a direct cooling heat exchanger. Adding a direct cooling heat exchanger in each substation with cooling demand is essential to improve energy efficiency. Simulation results showed that the annual electric energy consumption is reduced by 10 % when the direct cooling heat exchanger is added.

The connection between the three included papers is shown in the below illustration. Firstly, employing Modelica as a suitable modelling paradigm for fifth-generation district heating and cooling is reviewed and motivated in Paper I. Secondly, the design method for sizing the system components is implemented in a flat Modelica model and reported in Paper II. Thirdly, detailed modelling and simulation of substation components with Modelica is presented in Paper III.

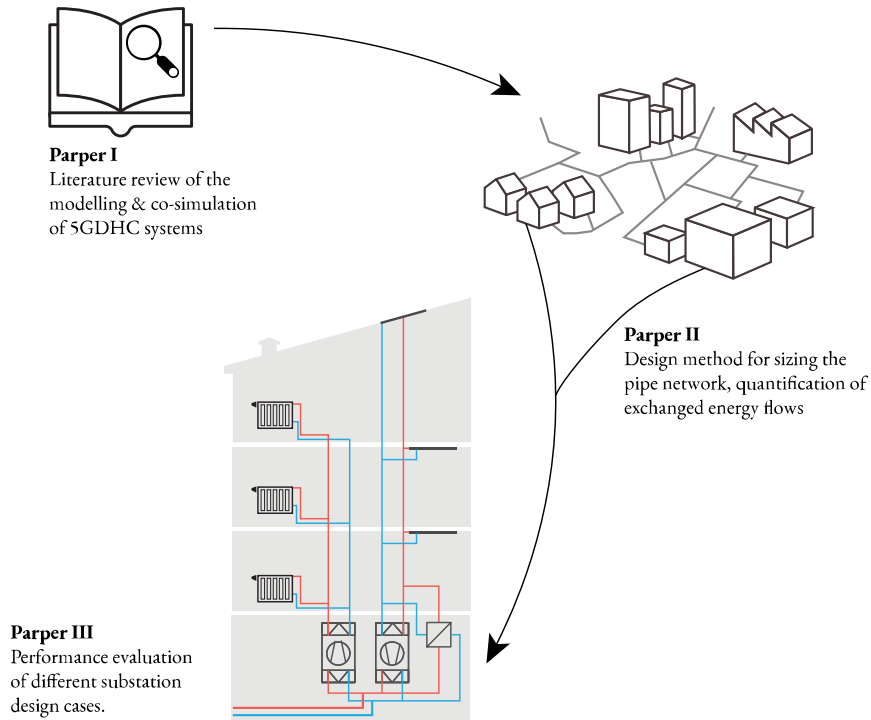

**Fig A.** The connection between the included papers in relation to the research main objective of developing a simulation model for a fifth-generation district heating and cooling system.

# 1 Introduction

This chapter begins with an overview of the world and Swedish energy situation and climate policies. Then, it sheds some light on the important role of district heating and cooling in the planning of future energy systems. Research objectives, method, and limitations are then presented. A deliberation about engineering ethics is provided as a background of the ethical risk analyses. The chapter closes with an overview of the structure of the dissertation.

## 1.1 Energy outlook

An energy system consists mainly of four parts: primary energy supply, central conversion, local conversion, and end-use (Frederiksen & Werner, 2013). Part of the total primary energy supplied to the energy system goes through central conversion processes to refine fuels and to generate electricity and heat. The converted energy is then delivered to the end-users where it can be used directly or go through local conversion. The previous parts of the energy system constitute complex flows between energy supply and energy consumption. In a world where the energy sector has seen unprecedented development during the past decades, investigating the energy balance starting from primary energy supply to final energy consumption becomes increasingly important. The investigation offers some important insights into several indicators, such as the energy situation of a country.

The Total Final Consumption (TFC) of energy in the world and Sweden is shown in Fig. 1.1. The measured TFC for the last three decades is categorised based on the energy sources explained in the legend. One can clearly see the continuous increase in global energy consumption. This increase is inextricably associated with global economic growth. For instance, the impact of the 2008 global economic crisis can be seen in the sudden drop of TFC in

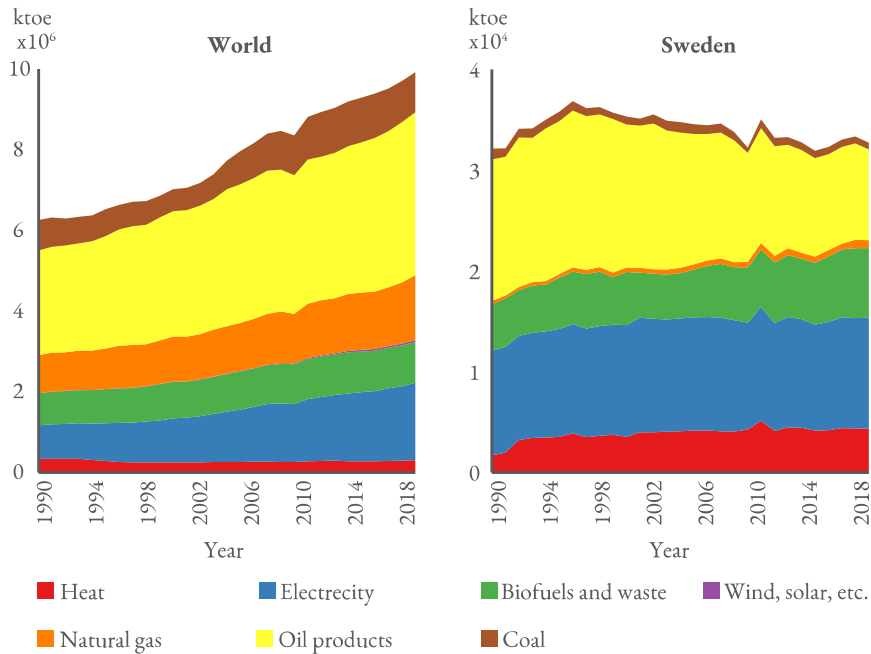

**Fig. 1.1** Total final energy consumption in the world (left) and in Sweden (right). The abscissa shows the year and the ordinate shows the energy consumption measured in kilotons of oil equivalent (ktoc), where 1 ktoc equals 11.63 Gigawatt hours. Data source: (International Energy Agency, 2020). Note that the two charts do not have a uniform scale.

the sum of 150 countries and regions included in the presented data. Moreover, the TFC in the world between 1990 and 2018 increased by an average of 1.6 %. In the same period, the world average Gross Domestic Product (GDP) increased by a similar rate with about 1.4 % increase (The World Bank, 2021). The association between energy consumption and economic growth is substantiated by the sharp increase in TFC in Sweden in 2010. The Swedish GDP per capita in 2010 peaked at 5 % following the 2008 economic crisis. However, the rate of energy consumption in Sweden has been decreasing during the last decade. One of the main causes attributed to this decrease is that Sweden is moving towards achieving its promising energy and climate goals, a topic that will be discussed in Section 1.2.

The strong association between energy consumption and economic growth remains evident during the COVID-19 pandemic. As the global economy has been severely affected by the lockdown, the primary energy consumption during 2020 decreased by almost 4 % (IEA, 2021b). Consequently, energy-related carbon emissions dropped by 5.8 % to mark the largest annual

percentage decline since the Second World War. To better understand the magnitude of this decline, we would need to remove all the European Union's carbon emissions from the global total to reach the same decline. Half of the decline in 2020 emissions was related to the drop in oil demands in the transportation sector. On the contrary, the residential sector faced an unprecedented increase in energy demand due to the imposed restrictions and changes in daily habits. A recent study compared measurements of energy consumption before and during COVID lockdown in 40 Canadian dwellings. The study showed that electricity and hot water use were increased by 46 % and 103 %, respectively (Rouleau & Gosselin, 2021). The large variation in energy consumption between the transport and residential sectors reveals the impact of the energy-consuming sectors on future energy markets.

Fig. 1.2 shows the percentage of the TFC by the different energy-consuming sectors. The percentages are almost similar between those in the world and Sweden. The energy sources presented earlier in Fig. 1.1 are used for various applications by different sectors. Heating and cooling are common

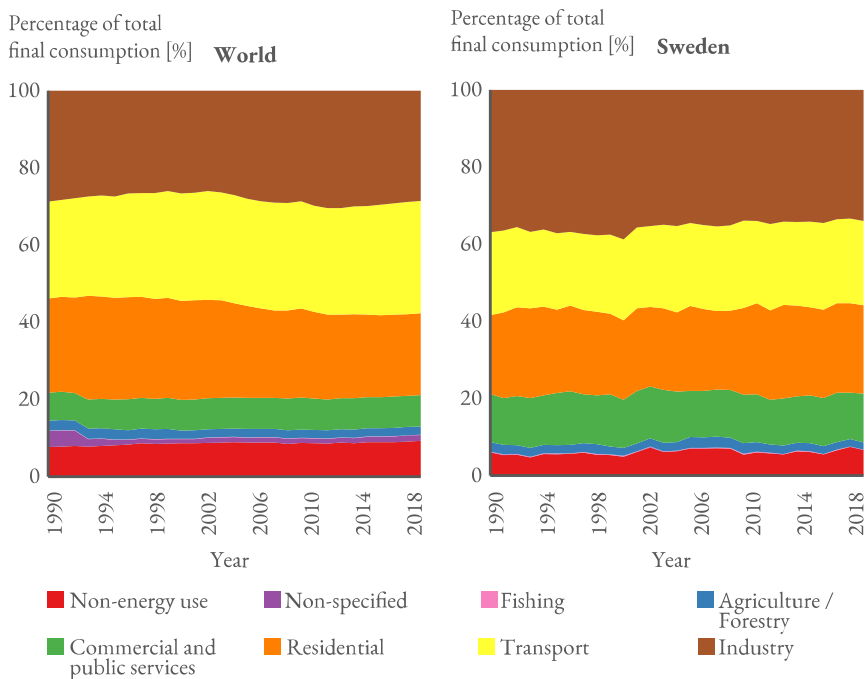

**Fig. 1.2** Percentage of total final energy consumption by different sectors in the world (left) and in Sweden (right). Data source: (International Energy Agency, 2020). Non-energy use includes fuels that are used as raw materials in the different sectors but are not used to produce energy.

applications in almost all energy-consuming sectors. Heating applications in the industrial sector involve, for example, producing steel, paper, glass, etc. About half of all industrial heat demand requires temperatures below 400 °C, where a share of about 60 % is related to heat demand below 250 °C (Hess, 2016). This demand includes low to medium temperature (< 100 °C) heat to reach a comfortable indoor climate inside industrial premises. The building sector requires low to medium temperature heat mainly for space heating and to produce domestic hot water. Cooling applications in the industrial and building sectors include, for example, space cooling for indoor thermal comfort, food storage, and cooling of computer data centres. The industrial and building sectors are responsible for one-third of the global TFC and 50 % of Europe's TFC (European Commission, 2016; IEA, 2021a). These numbers show that there are large potentials for achieving significant reductions in carbon emissions by improving the energy efficiency of heating and cooling systems.

## 1.2 Energy and climate policies

The world population is projected to reach 9.7 billion by 2050, where about 68 % are expected to reside in urban areas (United Nations, 2017). As a consequence, the number of households is projected to increase by 88 % between 2009 and 2050 (IEA, 2012). In light of these figures and the energy outlook discussed in the previous section, governments have enacted energy and climate policies aiming at reducing the environmental impact of carbon emissions. According to the Swedish Energy Ministry, “energy policy encompasses the production, distribution and use of energy. It aims to reconcile ecological sustainability, competitiveness and security of supply. It includes issues related to electricity, heating and gas markets, energy efficiency and renewable energy such as bioenergy, solar energy, and wind and hydropower.” (Government Offices of Sweden, 2021). The coming paragraphs introduce some of the important international and national policies related to the energy sector.

The Paris agreement adopted in 2015 aims to limit global warming to well below 2 °C (UNFCCC, 2015). The European Commission climate action framed a long term strategy to become climate-neutral by 2050 (European Commission, 2020). On a Swedish national level, the country has a target of becoming carbon-neutral by 2045 (Government Offices of Sweden, 2018). This national target goes in parallel with the energy policy agreement reached



in 2016, which stipulates that all electricity production should be 100 % from renewable sources by 2040 (Government Offices of Sweden, 2016). The previous policies have accentuated the role of the energy sector in the planning of future sustainable societies.

Achieving energy and climate targets entails developing innovative solutions for future building and community energy systems. These future systems should address technical challenges such as the integration of low-heat renewable sources, energy supply during extreme weather events, and energy conversion and utilisation between several sectors. District heating and cooling systems offer a range of possibilities to efficiently supply thermal energy and to be integrated with the electricity and transport sectors (Lund et al., 2014). In the Sustainable Development Scenario outlined by the International Energy Agency, district heating and cooling are seen as an integral part of future energy systems (IEA, 2020). The development of new generations of district heating and cooling networks increases the potential of integrating renewable energy sources as well as the utilisation of locally available waste heat.

## 1.3 Background of district heating and cooling

This section reviews the development of district heating and cooling and lists their possible benefits and drawbacks.

### *1.3.1 Evolution of district heating and cooling*

The evolution of district heating and cooling throughout five different development stages is depicted in Fig. 1.3. The first district heating network was realised in the 1870s in Lockport in the United States, where steam was used as a heat carrier (Frederiksen & Werner, 2013; Pellegrini & Bianchini, 2018). The steam had high risk of explosion and was therefore replaced by pressurized water in the second generation. Because traditional radiators in buildings were designed to cover space heating at about 80 °C, a new generation was developed with lower supply temperatures. The new third generation, also known as the Scandinavian district heating, was designed to operate with a network temperature of around 80 °C. Despite the current wide use of this generation, it has several challenges. For example, the centralised

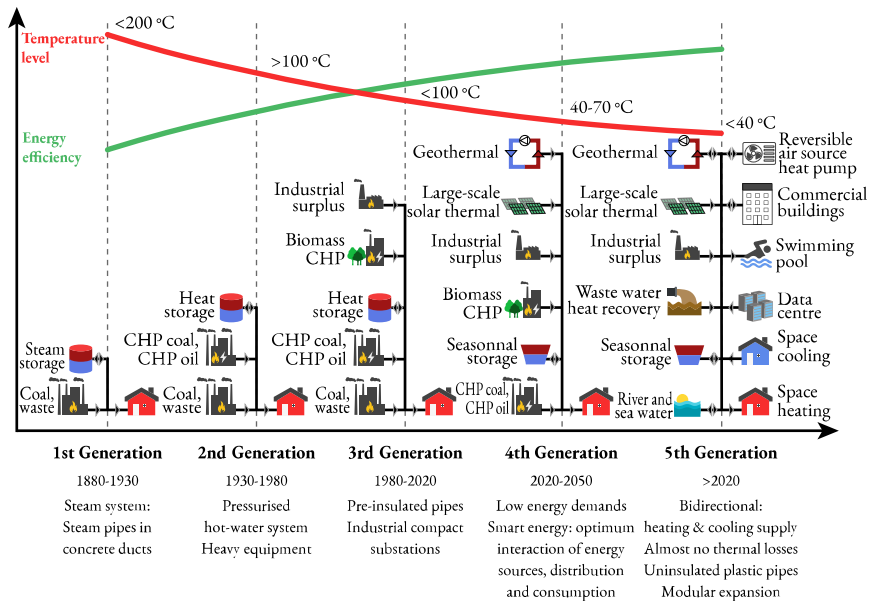

**Fig. 1.3** Evolution of district heating and cooling networks. The abscissa shows the evolution through five different generations and the ordinate shows the corresponding temperature level and energy efficiency. Black lines in each generation represent the pipe network, while arrows denote the direction of heat flow. A few examples of different energy sources and end-customers are depicted. Adopted from Lund et al. (2018) and Wirtz et al. (2020b).

heat production causes high network thermal losses. Moreover, the third generation limits integrating low-heat renewables sources such as shallow geothermal and solar thermal, which can reduce carbon emissions (Çomakli et al., 2004; Keebaş et al., 2011). The fourth generation addressed these issues by reducing the network operating temperature down to 40 °C. Despite the significant network temperature reduction, the fourth generation has yet two main issues. First, the network does not supply both heating and cooling through the same pipe network. Second, the centralised heat production limits the network expansion (Buffa et al., 2019). These challenges are addressed by today’s state-of-the-art fifth-generation district heating and cooling.

Fifth-generation district heating and cooling (5GDHC) leverages the synergies between connected buildings with simultaneous heating and cooling demands. Due to demand simultaneity, the heat carrier in the pipes can flow in either direction, resulting in a bidirectional network. The network in this generation is not designed to provide the required supply temperature at each connected building. Instead, decentralised heat pumps and/or chillers modulate the network temperature to the building temperature supply level.

Such network design enables supplying both heating and cooling through the same pipe network and reduces the network operating temperature close to the ground temperature. Moreover, 5GDHC can utilise the available waste heat from decentralised chillers condenser by supplying it to other connected buildings with heating demand. Detailed explanation about the system components and thermal interactions between connected buildings is provided in Section 3.

### *1.3.2 Benefits and drawbacks*

District heating and cooling systems have various technical, environmental and social benefits and few drawbacks that are reported in references (Frederiksen & Werner, 2013; Mazhar et al., 2018; Reinbold et al., 2019; Sepponen & Heimonen, 2016).

Benefits of district heating and cooling include:

- Economic feasibility in urban areas with high heat density.
- Increased potential of integrating low-heat renewable energy sources such as geothermal and solar thermal in comparison to individual building energy systems.
- High security of heat and cold supply to end-customers.
- Less floor areas for heating and cooling installations in connected buildings.
- Lower investment and maintenance costs for end-customers.
- Increasing social collaboration by connecting buildings suffering from energy poverty.

Drawbacks of district heating and cooling include:

- The natural monopoly of networks restricts price negotiation for individual customers.
- System failures will affect all buildings connected to the same network.
- System knowledge is exclusive to experts. The general users, therefore, have neither awareness nor control over their heat and cold supply.
- The selection of newly connected buildings to 5GDHC networks may involve ethical risks. Selection criteria based solely on demand balancing will favour certain types of buildings and exclude others. We shall explore the state of affairs surrounding this risk in Section 6.9.

## 1.4 District heating and cooling markets

The first commercial district heating networks were introduced in Lockport and New York in the United States in the 1870s and 1880s (Werner, 2017b). Nowadays, there are an estimated 80 000 district heating systems around the world (ibid). About 6000 of these systems exist in Europe, supplying about 12 % of the total heat (Euroheat & Power, 2017). District cooling, on the other hand, has much smaller deliveries compared to district heating. District cooling systems deliver about 7 % of the total cooling demand in residential buildings in the Middle East. While cooling of service buildings in the United States and Europe provided by district cooling is about 4 and 0.7 %, respectively.

In Sweden, the first district heating system was found in Karlstad in 1948 (Werner, 2017a). Today, there are about 500 district heating systems in Sweden with a market share of about 55 % of all heat supply to buildings. The total pipe length of these networks in 2014 was about 23 400 km. The annual distribution losses from the network in the same year was about 12 % of the heat supplied into the networks. By contrast, the total pipe length of district cooling in Sweden was 506 km in 2013. The latest figures in 2019 show that the total deliveries of district heating to final consumers was about 50 TWh, whereas only 1 TWh was delivered by district cooling (Statistics Sweden, 2019).

The Sankey diagram shown in Fig. 1.4 provides an understanding of the Swedish district heating energy balance in 2019. From left to right direction, the diagram shows three main stages of district heating energy balance. These are: 1) fuel and electricity input, 2) heat generation, and 3) heat delivery. It can be clearly seen that biomass accounts for most of the input fuel in the Swedish district heating. About 42 % of the fuel input to Combined Heat and Power plants (CHP) comes from biomass, whereas the share increases to 74 % of all input fuel to Heat-only-plants. Burning municipal solid waste comes after with about 37 % and 14 % of total fuel input to CHP and Heat-only-plants, respectively. Heat generation in Swedish district heating comes mainly from CHP and Heat-only-plants. However, there are other heat generation sources such as industrial excess heat, centralised heat pumps, electric boilers, and flue-gas condensation. Taken together, these heat sources have a share of 29 % of total heat generation to district heating. About half of the district heating final deliveries goes to multi-family houses. District heating also delivers low to

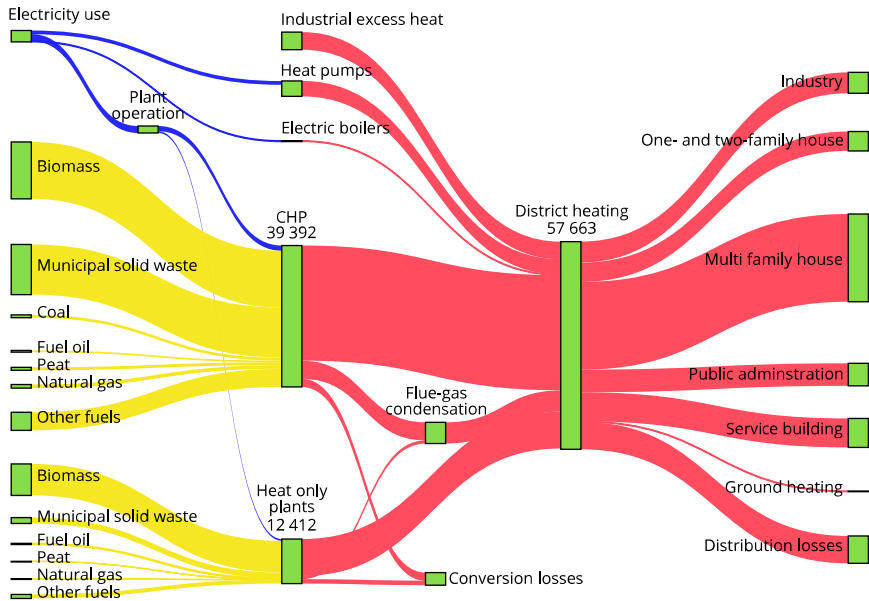

**Fig. 1.4** Sankey diagram for the Swedish district heating energy balance in 2019. The width of connecting bars is proportional to the quantity of heat flow measured in GWh. Different nodes in the energy balance are illustrated in green rectangles. Yellow and blue bars correspond to fuel and electricity input, while red bars denote heat flows from heat sources to final deliveries. Data source: Statistics Sweden and the Swedish Energy Agency (Statistics Sweden, 2019), while conversion losses are estimated by the author to complement the energy balance of CHP and Heat-only-plants.

medium temperature heat to the industry and for other purposes such as the de-icing of roads in winter. Large network distribution losses appear in the diagram with about 13 % of the final deliveries. Network losses remain similar to measurements in previous years.

## 1.5 Objectives of the dissertation

The dissertation has a fourfold objective. The main objective is to develop a simulation model for the fifth-generation district heating and cooling system installed in Lund, Sweden and presented in the Case Study section. A second objective is to characterise the components that constitute 5GDHC systems. A third objective is to demonstrate the modelling of system components using an equation-based object-oriented modelling approach with Modelica. A major contribution to research on 5GDHC systems is provided by unravelling the exchange of energy flows at different system levels. Deeper insights into the system are offered in two ways. First, visual illustrations of the flow

diagrams in building substations are presented. Second, the composition of the large district system in Modelica is demonstrated by assembling small component models. A fourth objective of the dissertation is to present ethical risk analyses of the different personal and organisational roles that may arise in 5GDHC business models.

## 1.6 Research method and limitations

This research follows the systems engineering process referred to as the V-diagram and presented in Fig. 1.5. In the context of 5GDHC systems, the process of developing a model to simulate the system is carried out at different levels. Level 0 represents the highest level of abstraction for specifying system requirements. The requirements for a 5GDHC system can include, for example, the choice for a suitable modelling paradigm, decentralised energy systems, external energy source(s), and distribution pipes. These requirements are discussed extensively in Section 2 and Section 3.1 as a part of the research background and method. At level 1, a preliminary design of the system is carried out where network design temperatures are considered, and capacities of energy systems are estimated. It is not necessary to examine design details at this level as these will be considered at later stages in the design process.

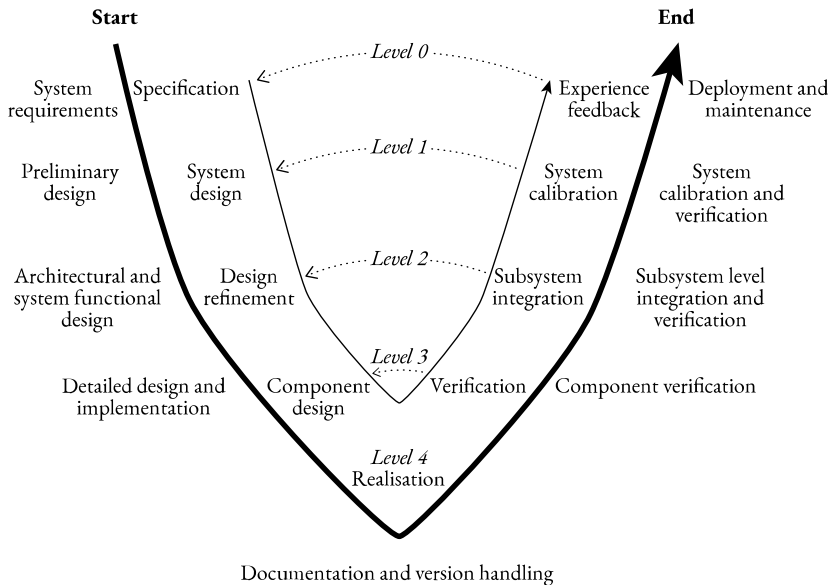
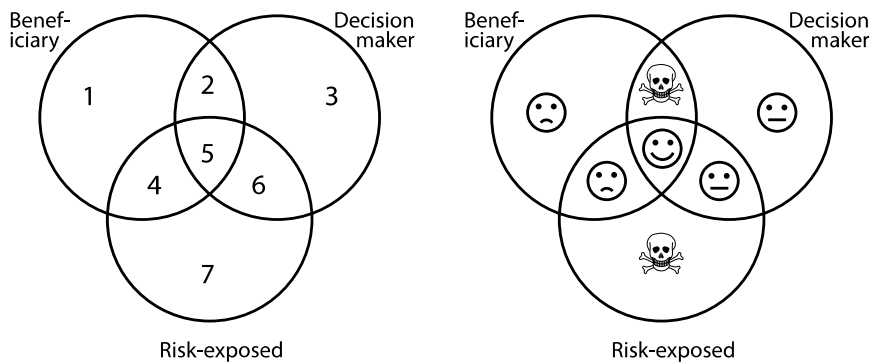

Fig. 1.5 The V-diagram for systems engineering process. Adopted from Fritzson (2004).

Preliminary system design is also related to the contents of Section 3.1. Functional design occurs at level 2 where technical aspects of the system are refined. One of these aspects can be, for example, the procedure of balancing demands within a building and between connected buildings. This procedure is described in detail in Section 3.2 related to substation operating modes. Level 3 focuses on component design and implementation that are presented in Section 4. The previous steps describe the design process of the system model from high to low level of details. Once the system model has been realised in the chosen modelling environment, verification takes place as seen in the upward arrow in the right half of the V-diagram. Verification involves internal consistency in the model and is applied on the lowest component level up to the system level where the system model is finally deployed. The process is repeated based on experience from end-users and when new design choices are adopted.

The method for the ethical risk analyses was adopted from the three-role analyses proposed by Hansson (2018) and is shown in Fig. 1.6. This kind of analyses aims at evaluating the role of each participant in the new business models that may arise in 5GDHC systems. The role of each individual or organisation can have various forms that are marked in seven numbers shown on the left side of Fig. 1.6. These forms are evaluated based on their role combinations as shown on the right side. When the distribution of the different roles between all individuals and organisations is not balanced, problematic roles occur. The ideal position for an individual or organisation to be in is field 5 where all participants make informed decisions by themselves, expose themselves to the business risks, and benefit from them. Performing ethical risk analyses is an attempt to ensure a fair role distribution among all



**Fig. 1.6** The seven forms of risk roles (left) and their evaluation (right). Adopted from Hansson (2018).

participants in 5GDHC business models.

Research limitations are classified into three main areas concerning connected buildings, the pipe network, and the balancing unit. First, the research does not engage with the building side of the substation. This implies that only building hourly demands, supply and return design temperatures are considered in the model and the building itself is left out of the scope. Second, the research does not aim to examine the heat losses between the pipe network and the ground nor implementing temperature and pressure control strategies. Straightforward free-floating temperature control was implemented with predefined lower and upper bounds. Third, the research is unable to encompass the entire possible design configurations of a balancing unit. The presented balancing unit model consists of heating and cooling plants that are realised in an air-source heat pump and chiller. This model reflects the physical behaviour of a reversible air-source heat pump that provides heating or cooling depending on the demand type. Following this approach, thermal energy storage in the balancing unit is considered beyond the scope of this research.

## 1.7 Deliberation about engineering ethics

As new research areas are being investigated and new technologies are developed, a science of ethics is necessary to ensure developing societies safely. Besides, researchers experience constant pressure to achieve energy targets and to innovate energy-efficient systems with competitive prices. Such a situation entails fostering an ethical discourse in the engineering domain to remind engineers to hold paramount the safety of the public before achieving any other goals. During the development of a new technology, new design choices are adopted, and advanced software controls are incorporated. These can lead to design or software flaws that may result in harmful consequences if the flaws are somehow masked and are not fully disclosed. Examples of problems related to design or software flaws can be found in different engineering domains, including the crashes of the Boeing 737 Max (Herkert et al., 2020), the massive radiation overdose in the Therac-25 radiation therapy machine (Leveson & Turner, 1993), the unintended acceleration in Toyota vehicles (Cummings & Britton, 2020), and the Deepwater Horizon oil spill (Kanso et al., 2020). Ethical lessons (re)learned from the previous examples reveal much about the need to foster ethical discourse between the public, engineers, and



decision-makers. Revitalising ethical-related issues between engineers during the design stage can help reduce potential design problems. In a new technology such as the fifth-generation district heating and cooling, new system designs and advanced control logics are incorporated. New business and price models also emerge in this generation, which can create new possibilities and, sometimes, conflict between the involved parties. Due to the changes in roles between the involved parties in a 5GDHC system, this study presents ethical risk analyses in Section 6.9 as an attempt to open more future discussions about the values of the technology and to ensure safe operation.

## 1.8 Overview of the dissertation

The dissertation is composed of seven themed chapters. A short description of the coming chapters is presented below.

### *Chapter 2. Model-Based System Engineering*

This chapter partly belongs to the research background and partly to the research method. First, it describes the equation-based object-oriented modelling approach used in model-based system engineering. Second, it reviews the available computational tools for modelling district heating and cooling systems. The use of Modelica for modelling district energy system is motivated and a short description of the modelling methodology is provided.

### *Chapter 3. System Architecture*

This chapter is part of the research method. The components that constitute a 5GDHC system are vetted and a detailed demonstration of the possible thermal interactions between substation components is presented.

### *Chapter 4. Models for System Analyses*

A significant part of the research method is presented in this chapter. It describes the physical behaviour of system components following a logical progression from small and easy-to-understand components to the assembly of large-scale complex district models.

### *Chapter 5. Case Study*

This chapter presents the research materials which consists of a cluster of 11 buildings located in Lund, Sweden. Lessons from the acquisition of heat meter data are first shared. The design specifications for the case study are then

presented. The description of the simulation cases and sensitivity analyses of network setpoints are introduced in this chapter.

*Chapter 6. Case Results and Discussion*

Results from the analyses performed on the case study are presented and discussed in this chapter. A comparison between two substation design cases is given based on different indicators such as Seasonal Coefficient of Performance, balancing unit performance, network temperature oscillation, and simulation performance. Results from the sensitivity analyses are presented and the impact of network setpoints is discussed. A categorisation of the district supply-demand structure at different system levels is also provided. Ethical analyses of an emerging business model in 5GDHC systems are also presented.

*Chapter 7. Conclusions and Future Research*

The dissertation closes by concluding the study findings and by listing future research areas.

## 2 Model-Based System Engineering

The International Council on Systems Engineering defines *Model-Based System Engineering* (MBSE) as: “the formalized application of modelling to support system requirements, design, analyses, verification and validation, beginning in the conceptual design phase and continuing throughout development and later life cycle phases.” (Friedenthal et al., 2007). One can view MBSE as a methodology that facilitates our exploration and understanding of the physical world around us. In modelling applications that follow the MBSE methodology, the behaviour of physical systems is described in mathematical models. When these mathematical models are implemented in a computer program, their artefacts are referred to as *virtual prototypes* (Fritzson, 2004).

The equation-based object-oriented Modelica language supports MBSE with a distinctive feature compared to imperative programming languages such as C/C++, Fortran or MATLAB/Simulink. The behaviour of the physical model developed in Modelica is described by equations where the computer assignments need not be specified to simulate the model (Wetter et al., 2016). Instead, a simulation environment analyses these equations and finds an optimal solution sequence by employing symbolic algebra. Therefore, model-based research with Modelica allows us to explain, control, and predict future events of complex physical systems that have not been built yet.

In this chapter, the general concept of modelling and simulation is first described. Thereafter, a literature review on the available computational tools for modelling district heating and cooling is presented. Lastly, the use of Modelica for modelling fifth-generation district heating and cooling systems is motivated, and the modelling approach is briefly explained.

## 2.1 The concept of modelling and simulation

A *model* is a representation of system entities that enables answering questions about the system (Fritzson, 2004; Hafner & Popper, 2017). Various experiments with a set of prescribed conditions can be applied to the model. These experiments are often called *simulations*. Each simulation is designed to answer specific questions about the system. For example, one simulation on a model representing a 5GDHC system can be used to answer design questions such as components sizes and investment cost. The majority of experiments aiming at sizing a particular system do not necessarily require a large simulation time scale. This is because most design problems are based on worst-case scenarios that usually occur at a single point in time. Alternatively, optimising system design and operation would require much more complex experiments, i.e., simulations. These involve manipulation of system parameters and controlling system variables during a larger simulation time scale.

Simulations have several advantages. It would be too expensive to perform empirical experiments on large physical systems to understand how they behave. Simulation is a feasible approach to study whether or not a particular system should be built. To build a model where simulations are performed, two types of knowledge are required. The first is concerned with the knowledge of the system itself including its functional requirements and expected behaviour. The second type of required knowledge is centred around the software where the simulations are performed. During the early stages of model development, the modeller needs to be aware of the model assumptions and its uncertainties. These have their impact on model accuracy and model management.

Fig. 2.1 shows the relationship between model management, degree of model capacity to reflect the real system, and knowledge of model parameter and uncertainty. First, the figure shows that significant efforts are required to handle models with detailed and complex equations. This would increase the risk of inadvertent errors which would impact the model accuracy negatively. Second, the right abscissa illustrated in the dashed line shows that both simplified and complex models decrease the level of knowledge about model parameters and their uncertainty. The previous two facts indicate that there exists an optimal for the aforementioned relationships. Within this optimal

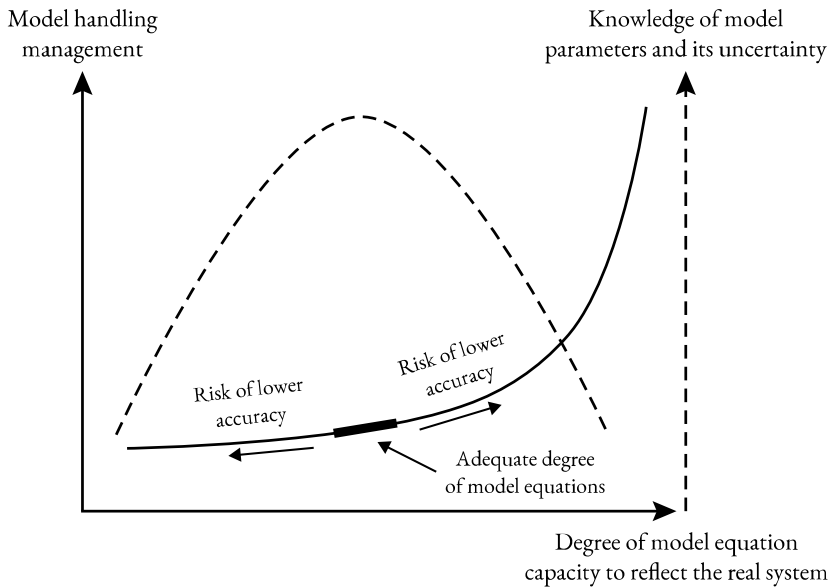

**Fig. 2.1** The optimal range of model accuracy concerning model management, degree of model equation capacity to reflect the real system, and knowledge of model parameter and uncertainty. Adopted from Steinkellner (2011).

range, the modeller has sufficient knowledge about model parameters and their uncertainty and where an appropriate level of model handling is required. The main goal for the modeller is to build models within this optimal range. This includes models for district heating and cooling systems.

## 2.2 Computational tools for modelling district heating and cooling

The introduction chapter presented the fundamental idea of district heating and cooling systems. These systems are substantially large and involve complex heat flows between system components. With such large-scale systems, it would be difficult to run experiments using physical prototypes to understand their behaviour. Computer-based modelling and simulation offer possibilities to design, analyse, and optimise complex physical systems. Nevertheless, the worldwide implementation of district heating and cooling systems is often neglected due to the lack of suitable tools dedicated to system design and optimisation (Talebi et al., 2016). This section focuses on the provision of suitable modelling frameworks for district heating and cooling systems.

Schweiger et al. (2018) compared four modelling tools that can be used to model district energy systems. The four tools include Simulink (MathWorks Inc, 2021), TRNSYS (Klein et al., 1976), IDA ICE (EQUA, 2021), and Modelica (Mattsson & Elmqvist, 1997). Dahash et al. (2019) compared eight tools for modelling district heating systems. They concluded that EBSILON®Professional (Steag-System Technologies, 2021) can serve as a tool for the initial design stage due to its fast computation time. For integrating renewable energy sources with district heating and cooling, Connolly et al. (2010) reviewed 37 tools that can be used for this purpose. A comprehensive online list of these tools is available in reference (Other tools - EnergyPlan, 2021).

Because each computational tool has its designated applications, features, and limitations, large district systems can be divided into subsystems that are modelled separately in individual tools. The analyses of the district system can then be performed using co-simulation. Many co-simulation frameworks have emerged over time and can be viewed in the work of Thomas et al. (2017). Appended Paper I reviews different studies that utilised co-simulation for building and district energy models. Currently, the most used framework for model exchange and co-simulation is the Functional Mock-up Interface (FMI) standard. Over 100 tools support the FMI standard, including tools for building and district energy simulations. A list of these tools is available in reference (Tools - Functional Mock-up Interface, 2019).

## 2.3 Modelling of district heating and cooling with Modelica

An international project was launched in 2012 by the International Energy Agency Energy in Buildings and Communities Programme (IEA-EBC) and aimed to develop free open-source, new generation computational tools for building and community energy systems based on the Modelica, Functional Mock-up Interface and Building Information Modelling Standards (Wetter et al., 2013). The Modelica language was developed through an international effort in 1996 and is being warmly received by the world community in modelling and simulation (Fritzson, 2004; Mattsson & Elmqvist, 1997).

Modelica is an equation-based object-oriented modelling language that supports acausal modelling of multi-domain complex physical systems. System models are built by a visual component programming method. An

icon represents a physical component where its behaviour is described by differential-algebraic and discrete equations. Each icon has a standardised interface that enables interfacing variables with other components through connector lines. This approach allows composing large systems in a Lego-like style.

Several studies reported successful use of Modelica for modelling district heating and cooling systems. Schweiger et al. (2017) presented a thermo-hydraulic dynamic optimisation of district heating and cooling systems based on the Modelica language. Modelica was used as a simulation executive in the recent study by Long et al. (2021) where a 5GDHC use case was applied on a developed metamodeling framework for building energy models. Appended Paper I motivates the use of Modelica for modelling and simulation of 5GDHC systems (Abugabbara et al., 2020). Sommer et al. (2020) used Modelica simulations to compare the novel single-pipe reservoir network to a bidirectional double-pipe network.

To model 5GDHC systems in Modelica, a top-down object-oriented approach based on finished library component models is recommended. The Modelica *Buildings* Library (Wetter et al., 2014) contains robust and validated models for buildings and community energy systems. These component models can be used to assemble large system models for applications related to 5GDHC systems.

## 2.4 Modelica simulation environments

Solving actual problems using the Modelica language requires the use of a Modelica simulation environment. The Modelica Association (2021) states three tasks performed by a Modelica simulation environment. Firstly, it transforms the graphical editing from the graphical user interface into a textual description in Modelica format. Secondly, it employs symbolic manipulation techniques to translate the Modelica model into a form that can be efficiently simulated. Thirdly, the simulation environment visualises the simulation results after the selection of an appropriate integration algorithm. In this research, the simulation environment DYNAMIC MOdelling LABoratory (Dymola) version 2020x (Brück et al., 2002) has been used. A complete list of the available free and commercial Modelica simulation environments can be seen in reference (Tools - Modelica, 2021)

## 2.5 Best practice

Modelling large physical systems has a relatively higher risk for inadvertent errors. It is, therefore, necessary to follow a practice that reduces this risk and ensures internal consistency in the model. Solving the problem of modelling large systems is no different than solving any other problem. We can find problem-solving best practices stored in books that preceded computer-based modelling, such as in the following approach explained by René Descartes:

“If we perfectly understand a problem, we must abstract it from every superfluous conception, reduce it to its simplest terms and, by means of an enumeration, divide it up into the smallest possible parts.”

– René Descartes, *Rules for the Direction of the Mind, Rule XIII*

In the context of modelling 5GDHC systems, the large system must be first divided into smaller and easy-to-understand subsystems. This process is described extensively in Section 3.1 in which the system is decomposed into three subsystems representing decentralised substations, balancing unit, and pipe network. Each of these subsystems can now be studied in isolation and can be divided up into even smaller parts to analyse the included components. For example, modelling decentralised substations can be reduced to the following three parts: 1) local energy systems for supplying building’s heating and cooling demands, 2) internal demand balancing between local energy systems, and 3) energy delivery from external sources to the substation.

The upshot of studying each small problem in isolation is that epistemic uncertainty about the large system is reduced. This includes knowledge about the system and its associated parameters. As presented earlier in Fig. 2.1, model accuracy increases as the knowledge of model parameters and their uncertainty increase. We shall see in the following two chapters how 5GDHCS systems can be modelled by following this practice.



## 3 System Architecture

This chapter characterises the components that constitute a fifth-generation district heating and cooling system. The different substation operating modes to supply building heating and cooling demands are then vetted schematically.

### 3.1 System components

A typical Fifth-Generation District Heating and Cooling (5GDHC) system enables connected buildings to exchange energy flows with each other. Looking at the system level depicted in Fig. 3.1, one can see how these energy flows are exchanged. The building with cooling demand located on the far left has a chiller that extracts water from the district cold pipe to provide space cooling. The chiller modulates the temperature of the extracted water to the desired supply temperature. The chiller operates through a typical refrigeration cycle where heat is removed from the building at the chiller evaporator and rejected to the district network at the chiller condenser. The rejected heat by chillers in conventional individual cooling processes is often referred to as waste heat. However, the waste heat in 5GDHC systems is rejected to the district warm pipe and exchanged with other buildings. Buildings with heat demands, such as the illustrated residential building, have heat pumps that extract water from the district warm pipe. Heat pumps in the building lift the temperature to the desired supply temperature for space heating and domestic hot water. Buildings with simultaneous demands for heating and cooling have both heat pumps and chillers that extract/reject energy flows from/to the network in the same process described earlier. In these kinds of buildings with simultaneous demands, heating and cooling are balanced internally within the building substation. The amount of extracted/rejected energy from/to the network depends on which category is dominant between heating and cooling. If the exchanged energy flows

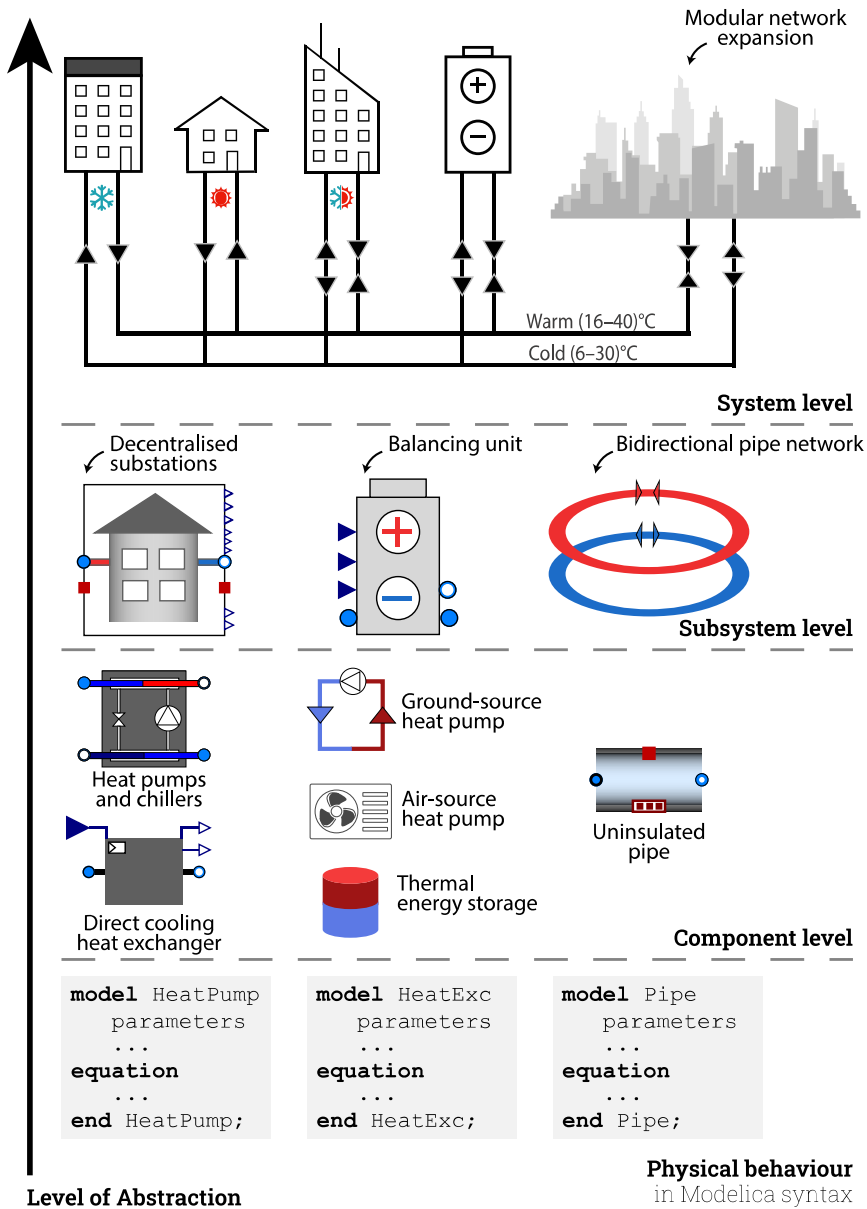

**Fig. 3.1** The architecture of a fifth-generation district heating and cooling system. At the lowest level of abstraction, component physical behaviour is described by differential-algebraic and discrete equations. At the highest level of abstraction, components are assembled to compose the large system.

between all connected buildings are not ideally balanced, a balancing unit is realised. The balancing unit injects heat into the network in case of dominant heat demand. It extracts energy out from the network when cooling demand

dominates. When a set of buildings are connected to this kind of district networks, they form a module that is commonly referred to as a cluster.

System modularity provides high flexibility for future network expansion. Unlike previous generations, the size of the network is no longer constrained by the capacity of the heat production units. Instead, the network is perceived as a modular unit that can be easily expanded and integrated with other modules, since heat production is decentralised. From a purely technical perspective, the main factor that decides if a network can be expanded is the impact of newly connected buildings on the efficiency of the network. However, Zarin et al. (2018) argue that district systems are also built for community resilience where energy efficiency is not always the sole deciding factor.

The different levels of abstraction shown in Fig. 3.1 also represent the hierarchical modelling approach considered in Modelica. Component models are described by differential-algebraic and discrete equations and represented by icons. Several components are assembled to compose a subsystem model. Subsystem models are finally configured to build the system model. Decentralised substations, for example, are composed of several components such as heat pumps, chillers, and direct cooling heat exchangers. The design of the substation may differ from one case to another and additional components may be required. Another example of a balancing unit may involve different components. The primary function of the balancing unit is to compensate for energy imbalances in the network due to mismatches between heating and cooling demands. This can be achieved by injecting heat into the network when network heat demand dominates. Conversely, it extracts heat when cooling demand dominates. The balancing unit may include a thermal energy storage system that utilises available excess heat for later use. It can also include components such as a ground-source heat pump, air-source heat pump, or cooling towers. Finally, a pipe component model with no insulation and where the flow direction can be reversed complements the main components in a 5GDHC system. Section 4 describes the main equations that reflect the behaviour of most of these components.

## 3.2 Substation operating modes

Demand balancing in 5GDHC networks takes place first inside each substation. The quantity of heating and cooling demands at a particular point in time determine the amount of energy extracted/rejected from/to the

network. As mentioned earlier, heat pumps and chillers in substations modulate the network temperature to the desired supply temperature. This means that the performance of heat pumps and chillers plays a significant role in balancing the substation demands. Moreover, different operating modes between substation components influence the demand balancing process.

The substation illustrated in Fig. 3.2 shows the flows between substation components. The connections between the heat pump, the chiller, and the direct cooling heat exchanger make the substation act as a district system that exchanges energy flows when seen from within. Energy flows are exchanged between the different components according to demand type and operated components. For example, the heat pump condenser provides the heat demand. Simultaneously, the low-temperature heat at the evaporator is utilised to provide direct cooling through the heat exchanger. In this operating

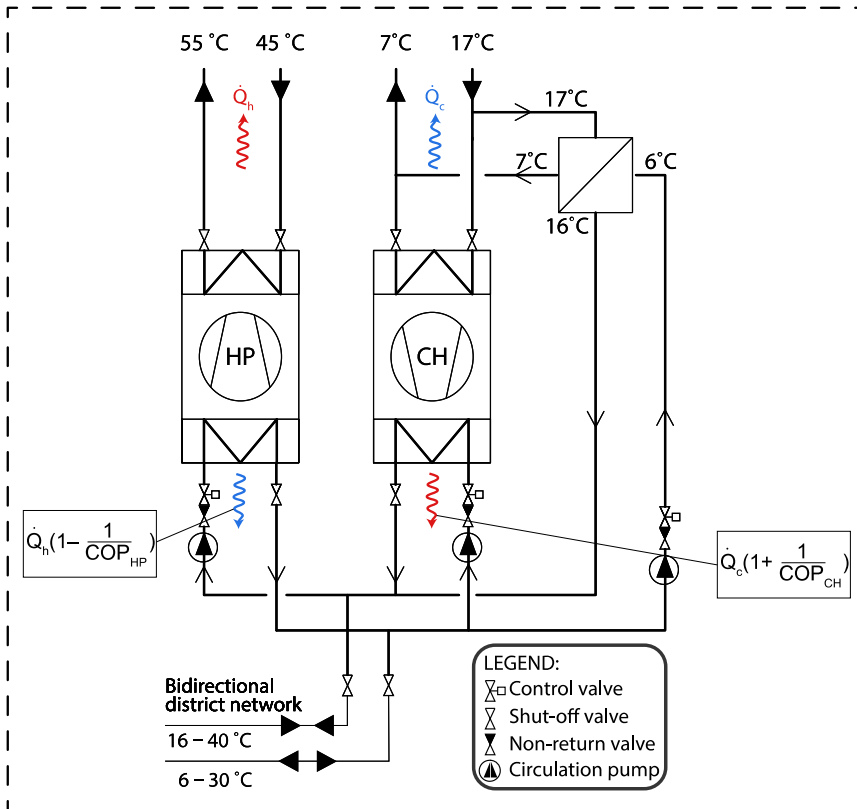

Fig. 3.2 Demonstration of demand balancing in a substation with installed heat pump, chiller, and direct cooling heat exchanger. Temperature levels are provided for guidance.

mode, demand balance occurs when:

$$\dot{Q}_c = \dot{Q}_h \left(1 - \frac{1}{COP_{HP}}\right) \quad \forall t \in \mathcal{T} \quad \text{Eq. 3.1}$$

where  $\dot{Q}_c$  and  $\dot{Q}_h$  are the respective building cooling and heating demands. The capacity of the direct cooling heat exchanger and the temperature levels at the heat exchanger primary and secondary sides determine whether direct cooling is realised or not. In case the conditions to utilise direct cooling are not satisfied, the chiller instead provides all required cooling. The demand balance in Eq. 3.1 is then adapted to include the chiller COP and is expressed as:

$$\dot{Q}_h \left(1 - \frac{1}{COP_{HP}}\right) = \dot{Q}_c \left(1 + \frac{1}{COP_{CH}}\right) \quad \forall t \in \mathcal{T} \quad \text{Eq. 3.2}$$

The following sections provide more insights into the different possible operating modes that appear in a substation.

### 3.2.1 Only heating mode

This operating mode is the simplest and most straightforward. The heat pump illustrated in Fig. 3.3 first absorbs heat in the evaporator from the low-temperature district source. The heat pump transfers thermal energy from the low-temperature district source to the high-temperature building sink. Temperatures at the source and the sink determine the performance of the heat pump. The heat pump COP increases with decreasing temperature difference between the heat sink and heat source.

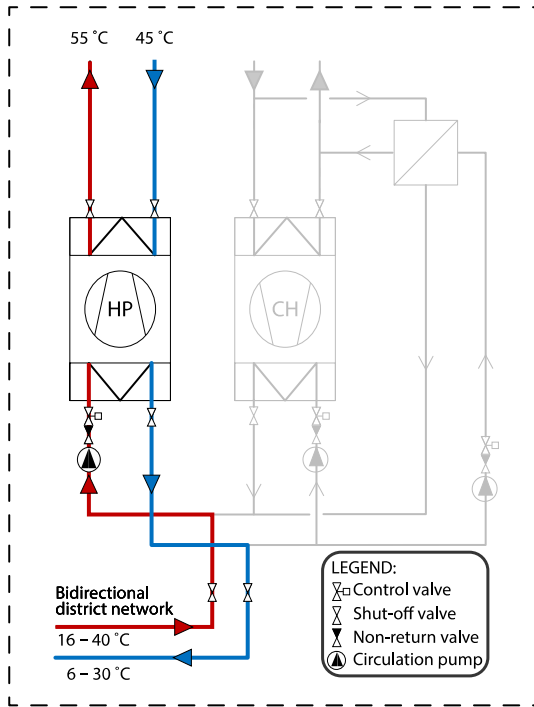

**Fig. 3.3** Schematic diagram of the water flows in a substation with only heating demand at a particular point in time.

### 3.2.2 Only cooling mode

Cooling demand can be supplied by the direct cooling heat exchanger, or by the chiller, or by a combination of both. When the temperature of the district cold pipe is lower than the building cooling return temperature, direct cooling can be possible (Wirtz et al., 2020a). The water flow diagram in this operating mode is depicted in Fig. 3.4(A). When direct cooling is not possible, electric work in the chiller modulates the district source temperature to the desired supply level. Connections between the chiller and the district network are shown in Fig. 3.4(B). It is possible for the direct cooling heat exchanger and the chiller to operate in a combined mode. This operating mode occurs when the conditions to utilise direct cooling are fulfilled, but the capacity of the heat exchanger is lower than the required cooling demand.

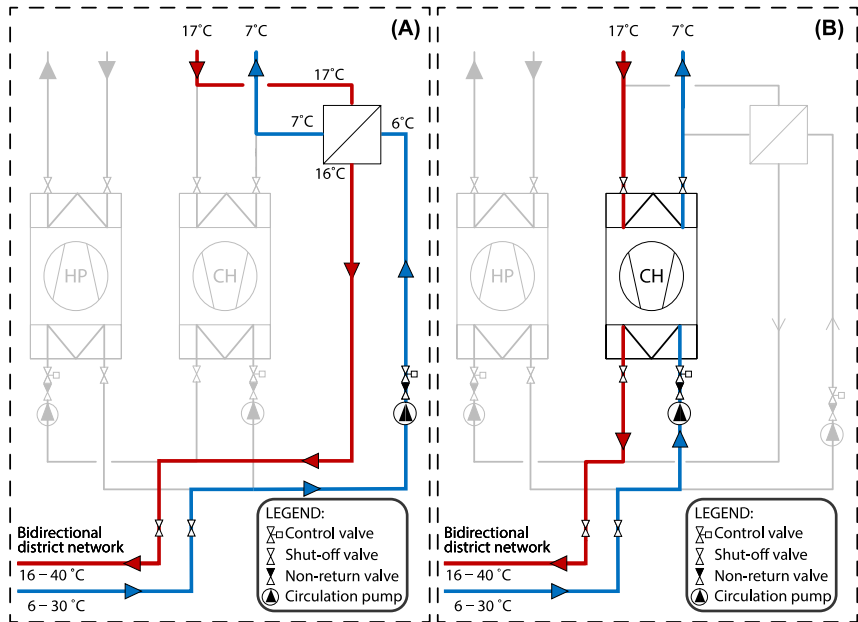

**Fig. 3.4** Schematic diagram of the water flows in a substation with only cooling demand at a particular point in time. The diagram shows water flows when direct cooling is utilised (A) versus when a chiller is in operation (B).

### 3.2.3 Dominant heating mode

Fig. 3.5 shows the water flows in a substation with simultaneous heating and cooling demands and where heating dominates. Here, the available energy at the evaporator is sufficient to cover the cooling demand through the direct cooling heat exchanger. If the evaporator outlet temperature is lower than the building cooling return temperature, direct cooling can be utilised as shown in the figure. If the previous condition does not hold, the chiller operates in connection with the heat pump such that the outlet from the heat pump evaporator flows into the chiller condenser inlet. The amount of balanced energy between the heat pump and the direct cooling heat exchanger can be derived from Eq. 3.1, whereas when the chiller operates Eq. 3.2 is used instead.

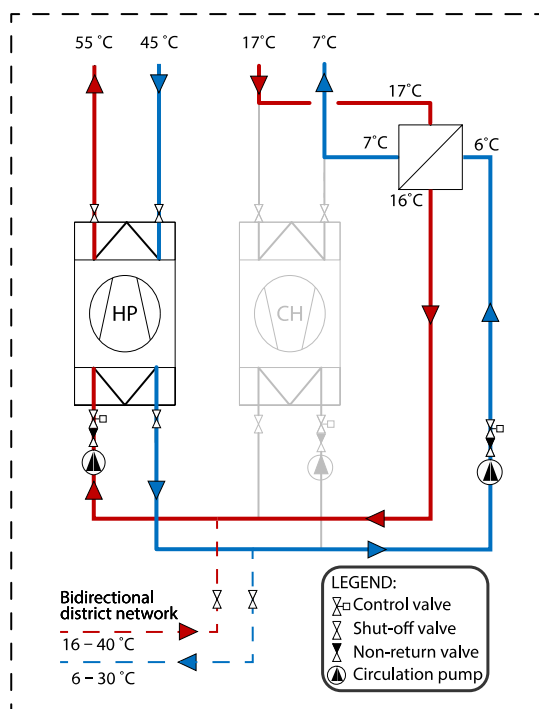
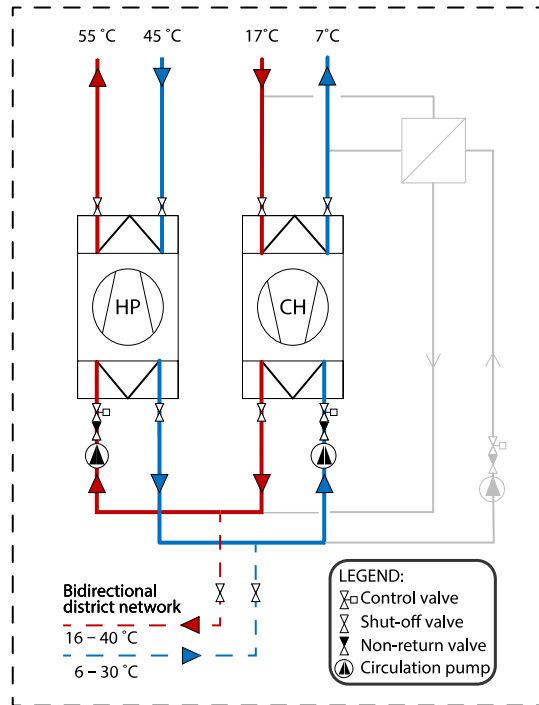

**Fig. 3.5** Schematic diagram of the water flows in a substation with simultaneous heating and cooling demands and where heating demand dominates at a particular point in time. The heat pump is also utilised for direct cooling.



### 3.2.4 Dominant cooling mode

In this operating mode, the chiller operates first to supply the required cooling in addition to exchanging the heat at the condenser with the heat pump evaporator, as illustrated in Fig. 3.6. The heat rejected by the chiller condenser is used as a source for the heat pump. The rejected heat can have a higher temperature than the district warm pipe, which consequently increases the heat pump COP. This operating mode occurs frequently in the summer season where space cooling is required and when simultaneous demand for domestic hot water exists.



**Fig. 3.6** Schematic diagram of the water flows in a substation with simultaneous heating and cooling demands and where cooling demand dominates at a particular point in time. Chiller's waste heat is used as a source for the heat pump.



# 4 Models for System Analyses

This chapter describes the physical behaviour of the models used for analysing fifth-generation district heating and cooling systems. First, the derivation of thermo-fluid properties at fluid ports is explained. Component models from the Modelica *Buildings* library are then presented. The chapter closes with a demonstration of components assembly to compose a district grid model.

## 4.1 Fluid ports

The notion of component standardised interfaces in Modelica has been briefly touched in Section 2.3. These interfaces propagate variables between *connected* components when models of complex physical systems are assembled. Connectors are also referred to as ports and have two distinct kinds of variables that are exchanged between components. The first is *potential* variables that change the system behaviour based on their value (Tiller, 2014). Typical examples of potential variables in the thermal and fluid domains are temperature and pressure. The other kind of variables is *flow* variables that represent a time derivative of a conserved quantity. In the thermal domain, *heat* is the time derivative of the conserved quantity *energy*. In the fluid domain, *mass flow* is the time derivative of the conserved quantity *mass*. Depending on the kind of variable, two types of coupling can be established by connections (Fritzson, 2004). The first kind of coupling is equality coupling for potential variables. The second kind of coupling is sum-to-zero coupling for flow variables. Consider an example of a pipe model connected to a tank where water is drawn from the tank and flows through the pipe until supplied to an infinite sink. The connection line between the pipe and the tank satisfies the conditions that the sum of mass flows across the connected ports returns zero, and that the pressure at the connected ports is equal. Assigning

positive and negative values to the mass flow based on its direction is, therefore, necessary for the sum-to-zero coupling of flow variables. In the models explained in the remaining sections of this chapter, the relationship between mass flow rate and pressure drop is defined as:

$$\dot{m} = \text{sign}(\Delta p) k \sqrt{\Delta p} \quad \forall t \in \mathcal{T} \quad \text{Eq. 4.1}$$

The constant  $k$  is derived from nominal design parameters and is equivalent to:

$$k = \frac{\dot{m}_{nom}}{\sqrt{\Delta p_{nom}}} \quad \text{Eq. 4.2}$$

The fluid temperature and enthalpy are also computed at each port. For water medium, specific enthalpy is expressed as:

$$h_w = c_{p,w} T \quad \forall t \in \mathcal{T} \quad \text{Eq. 4.3}$$

While specific enthalpy for moist air is formulated as:

$$h_{moist\ air} = c_{p,dry\ air} T + x[c_{p,w} T + h_{vapor}] \quad \forall t \in \mathcal{T} \quad \text{Eq. 4.4}$$

The previous variables establish the standard connections between the different components included in a 5GDHC system.

## 4.2 Model for heat pumps

Heat pumps are modelled as a Carnot cycle with unlimited capacity. The heating supply temperature is prescribed at the condenser. Depending on the heat pump type, the medium at the source and sink sides can be selected from a predefined list of medium properties. For heat pumps located in the decentralised substations and presented in this section, water-to-water heat pumps are considered. The heat pump model is shown in Fig. 4.1 and a description of the presented components is provided in Table 4.1. The mass flow rate at fluid port A1 represents the return from the building heating water loop and is equivalent to:

$$\dot{m}_{ret,b} = \frac{\dot{Q}_h}{\Delta T_{cond} c_{p,w}} \quad \forall t \in \mathcal{T} \quad \text{Eq. 4.5}$$

After the condenser exchanges thermal energy with the building heating water loop, water is supplied to the building sink with the corresponding prescribed temperature at fluid port B1. On the district side at fluid port A2, the circulation pump draws water to the evaporator inlet in the amount of:

$$\dot{m}_{evap} = \frac{\dot{Q}_{evap}}{\Delta T_{evap} c_{p,w}} \quad \forall t \in \mathcal{T} \quad \text{Eq. 4.6}$$

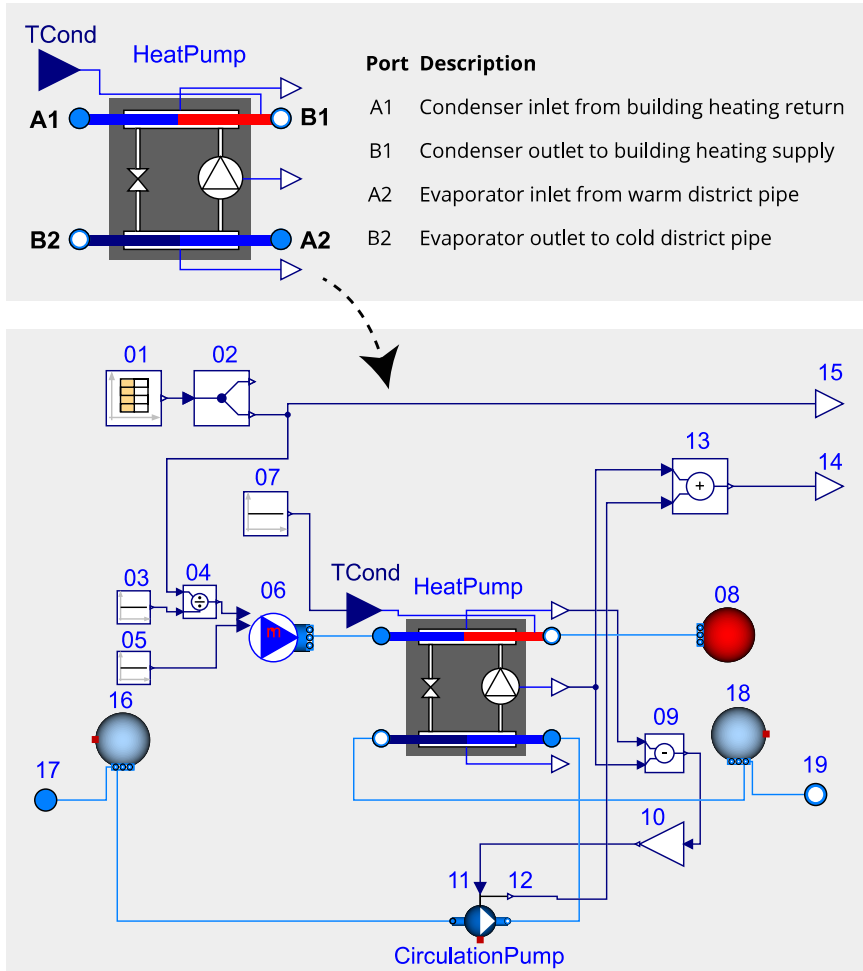

**Fig. 4.1** An instance of a heat pump model with prescribed condenser leaving temperature (top). Parametrised and connected heat pump model in a model that represents a substation with only heating demand (Bottom). Actual component names are substituted with ID numbers that are described in Table 4.1.

**Table 4.1** Description of components shown in Fig. 4.1.

Component ID	Description
01	Matrix with building heating and cooling demands
02	Split of building demands and output the heating demand
03	$Heating\ gain = \Delta T_{cond} c_{p,w}$
04	$\dot{m}_{cond} = \dot{Q}_h / Heating\ gain$
05	Building heating return temperature
06	Mass flow source with input signals and prescribed temperature
07	Prescribed condenser leaving temperature
08	Building heating sink
09	$\dot{Q}_{evap} = \dot{Q}_{cond} - P_{comp}$
10	$\dot{m}_{evap} = \dot{Q}_{evap} / (\Delta T_{evap} c_{p,w})$
11	Circulation pump mass flow rate input
12	Circulation pump electric power output
13	Compressor and circulation pump electric power
14	Substation total electric power
15	Substation heating demand
16	Substation delay from warm district pipe
17	Fluid port for external connection with warm district pipe
18	Substation delay from cold district pipe
19	Fluid port for external connection with cold district pipe

The heat flow in the evaporator is expressed as:

$$\dot{Q}_{evap} = \dot{Q}_h - P_{comp} \quad \forall t \in \mathcal{T} \quad \text{Eq. 4.7}$$

The compressor power in the heat pumps is computed as:

$$P_{comp} = \frac{\dot{Q}_h}{COP_{HP}} \quad \forall t \in \mathcal{T} \quad \text{Eq. 4.8}$$

To better understand the behaviour of the heat pump model, we will consider the example shown in the bottom diagram in Fig. 4.1 for which the description of components is provided in Table 4.1. The diagram shows the internal structure of a substation model with only heating demand. Starting from the top left corner of the diagram, the building hourly annual heating demand is prescribed in component 01. Because this substation model has only heating demand, component 02 splits the matrix and takes only the vector of the heat demand. Mass flow from the building return is described in

components 03 to 06 according to Eq. 4.5. The desired condenser leaving temperature is defined in component 07 where a controlled leaving temperature based on the outdoor weather can be defined. Mass flow at the evaporator inlet is described in components 09 to 11 as the formulation in Eq. 4.6 and Eq. 4.7. The remaining components are used to connect the substation with the district pipes and to present the results of the heat pump performance. The heat pump COP is adjusted in the model according to a prescribed Carnot efficiency as:

$$COP_{HP} = \eta_{Carnot} \frac{T_{cond}}{T_{cond} - T_{evap}} \quad \forall t \in \mathcal{T} \quad \text{Eq. 4.9}$$

The actual condenser and evaporator temperatures consider the pinch temperature between the fluid and the refrigerant as an input parameter. Moreover, the part load ratio of the heat pump at a particular point in time has an impact on the condenser and evaporator temperatures. The actual condenser temperature is expressed as:

$$T_{cond} = T_{portB1} + \left( \frac{\dot{Q}_h}{\dot{Q}_{cond,nom}} T_{pinch,cond} \right) \quad \forall t \in \mathcal{T} \quad \text{Eq. 4.10}$$

Nominal condenser  $\dot{Q}_{cond,nom}$  load is equivalent to the building peak heating demand. At nominal operating mode, the actual condenser temperature is equal to the required heating supply temperature at port B1 while taking into account the rise due to pinch temperature. Similarly, the actual evaporator temperature is formulated as:

$$T_{evap} = T_{portB2} - \left( \frac{\dot{Q}_{evap}}{\dot{Q}_{evap,nom}} T_{pinch,evap} \right) \quad \forall t \in \mathcal{T} \quad \text{Eq. 4.11}$$

Chillers are modelled in a similar way to the heat pump model described in this section. The main difference is that the condenser now represents the source and is connected to the district pipes. On the other hand, the evaporator represents the building sink and is connected to the building cooling circuit.

### 4.3 Model for circulation pumps

This model has the following three options to describe the mass flow rate input: 1) constant mass flow rate, 2) multiple stages, and 3) continuously varying mass flow rates. The latter is shown in Fig. 4.2 where the circulation pump power is derived from continuous mass flow rate input as:

$$P_{pump} = \frac{\dot{V} \Delta p}{\eta_h \eta_m} \quad \forall t \in \mathcal{T} \tag{Eq. 4.12}$$

where  $\eta_h$  and  $\eta_m$  denote the pump hydraulic and motor efficiencies, respectively. The pressure rise is derived as expressed in Eq. 4.1 with a default reference pressure for water equals 300 000 Pa. The reference pressure is prescribed as a default value in the water package included in the Modelica *Buildings* library. Default values can be easily modified by the user to specify the system design requirements in different cases.

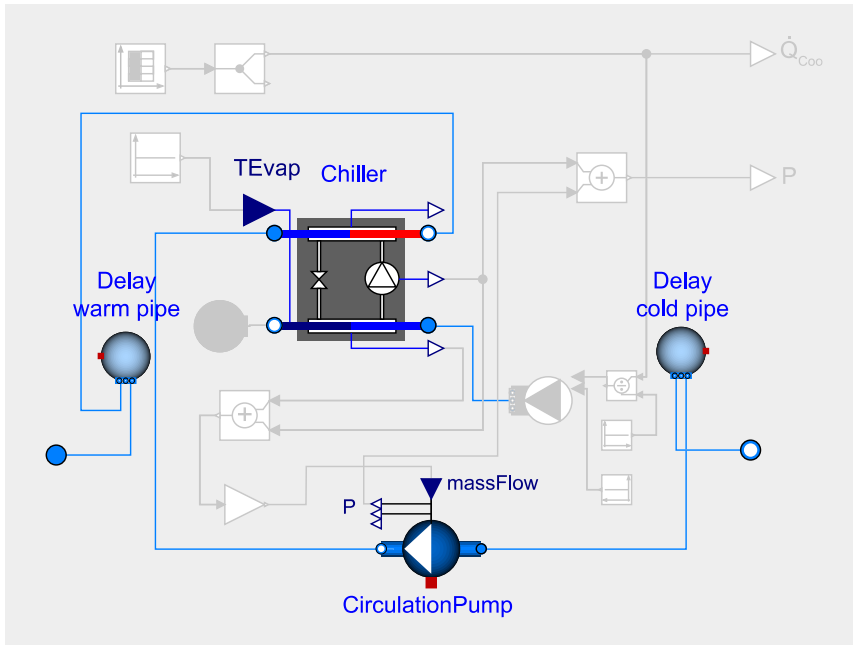
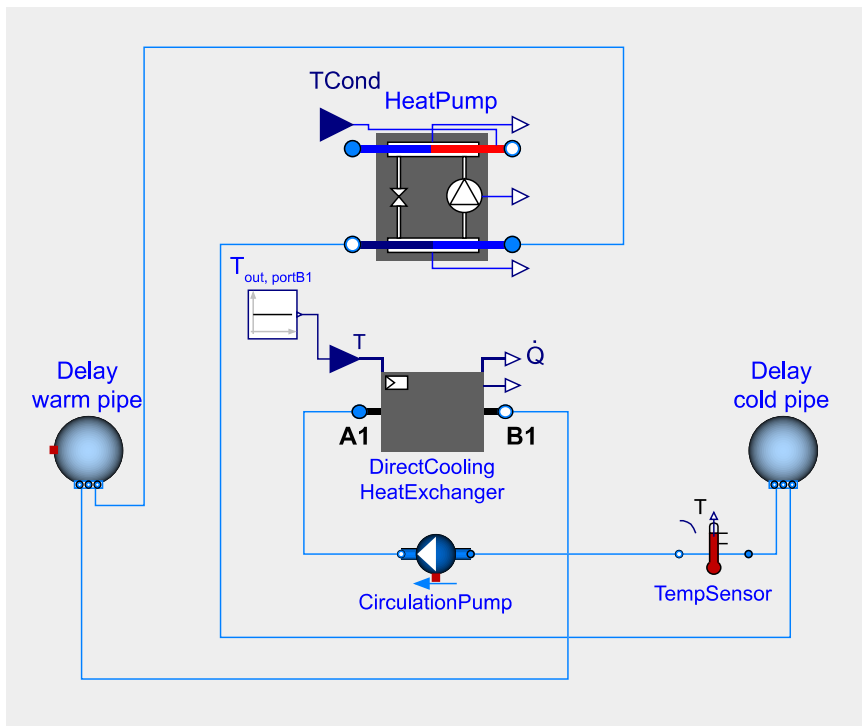

**Fig. 4.2** Model of a substation with only cooling demand. The highlighted components demonstrate how the circulation pump continuously draws water from the cold district pipe to the chiller condenser inlet to meet the demand for space cooling.



## 4.4 Model for direct cooling heat exchangers

The conditions for operating the direct cooling heat exchanger have been explained in Section 3.2.2. The model diagram depicted in Fig. 4.3 shows the connections between the direct cooling heat exchanger and the heat pump evaporator. The diagram demonstrates the operating mode presented previously in Fig. 3.5. The water in the evaporator outlet flows into the mixing volume where the district cold pipe is connected from the outside. The temperature sensor measures the temperature in the evaporator to determine whether the conditions to realise direct cooling are fulfilled. When direct cooling can be utilised, the circulation pump draws water to the heat exchanger inlet. The presented model of the heat exchanger requires a prescribed outlet temperature as an input. In the example shown in Fig. 4.3,



**Fig. 4.3** A snippet of a model diagram showing how the heat pump evaporator is utilised for direct cooling. The diagram does not show all components and connections in the real model to demonstrate the flows in the direct cooling heat exchanger as shown in the schematic in Fig. 3.5.

the temperature difference between the heat exchanger inlet and outlet is constant at 10 K. Therefore, the outlet temperature can be prescribed based on the measured inlet temperature. The mass flow rate in the primary side of the heat exchanger is identical to the mass flow rate in the heat pump evaporator, and the rate of transferred heat is equivalent to:

$$\dot{Q} = \dot{m}_{evap}(h_{out} - h_{in}) \quad \forall t \in \mathcal{T} \quad \text{Eq. 4.13}$$

As the model diagram shows, the building side of the heat exchanger is not modelled. It was sufficient to model the direct cooling heat exchanger following the approach explained earlier. Modelling the direct cooling heat exchanger without modelling the building side was also reported in the modelling of the reservoir network in reference (Sommer et al., 2020).

## 4.5 Model for decentralised substations

The previous sections provided insights into using existing Modelica components to build new models. Fig. 4.1 and Fig. 4.2 presented model diagrams of substations with only heating or cooling demand. The diagrams demonstrated the internal structure of the substation and the connections between model components. The icon view of the substation model illustrates how the model is connected from the outside when variables are exchanged with other components. Fig. 4.4 shows substation icon views in the Modelica simulation environment Dymola. The substation depicted in the red building represents a building with only heating demand. Similarly, the blue building icon denotes a building with only cooling demand. For a building with heating

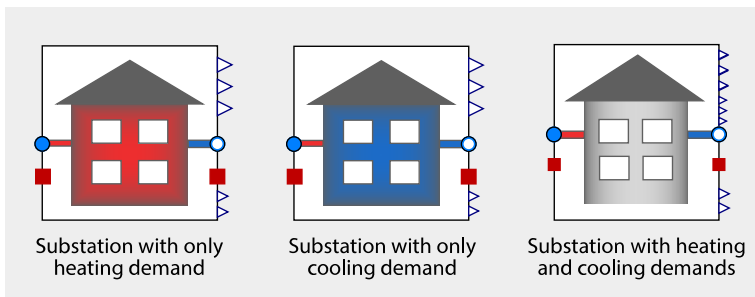

**Fig. 4.4** Icon view of the Dymola Substation models where icons encapsulate the internal physical structure of the substation. Blue circles denote fluid ports and are to be connected with district pipes, red squares represent heat ports for substation fluid temperature, while arrows interface the substation thermal and electric power.

and cooling demands, the internal structure of the substation model is adapted to include both the heat pump and the chiller. The icon for a substation with heating and cooling demands is represented in the grey building in Fig. 4.4.

All substation models consider the fluid transport delay which is presented in components number 16 and 18 in Fig. 4.1. These components reflect mixing volumes that include the substation delay. The delay refers to the time it takes for a temperature change to be absorbed by the system. This delay is often referred to as a first-order lag and is described by a time constant (ASHRAE Handbook Committee, 2017). If sensible heat is added into the volumes, it can be described in the heat port shown in red squares in substation model icons. The blue and white circles denote fluid ports for the connection with the district warm and cold pipes, respectively. The output signals represented in white triangles interface variables related to substation performance. All substation models can adopt an additional heat pump to produce domestic hot water.

## 4.6 Model for balancing unit

The balancing unit can have different design configurations and may consist of several components. This section presents a balancing unit model with heating and cooling plants realised in air-source heat pump and chiller. This model reflects the behaviour of a reversible air-source heat pump that provides heating or cooling depending on the demand type and pipe temperatures. For instance, dominant heating demand across connected buildings indicates that water is continuously drawn by substations from the district warm pipe. The reversible air-source heat pump injects heat into the network to keep the warm pipe temperature from falling below a setpoint. Conversely, the reversible heat pump extracts heat from the network by providing cooling that keeps the district cold pipe temperature below a setpoint. These setpoints and the temperature of the ambient air are defined in the dark blue inputs in the balancing unit model shown on the left of Fig. 4.5. The network setpoints used in this study are 16 °C for heating and 30 °C for cooling. The network temperature range under a temperature difference of 10 K can be seen in all figures presented earlier in chapter 3.

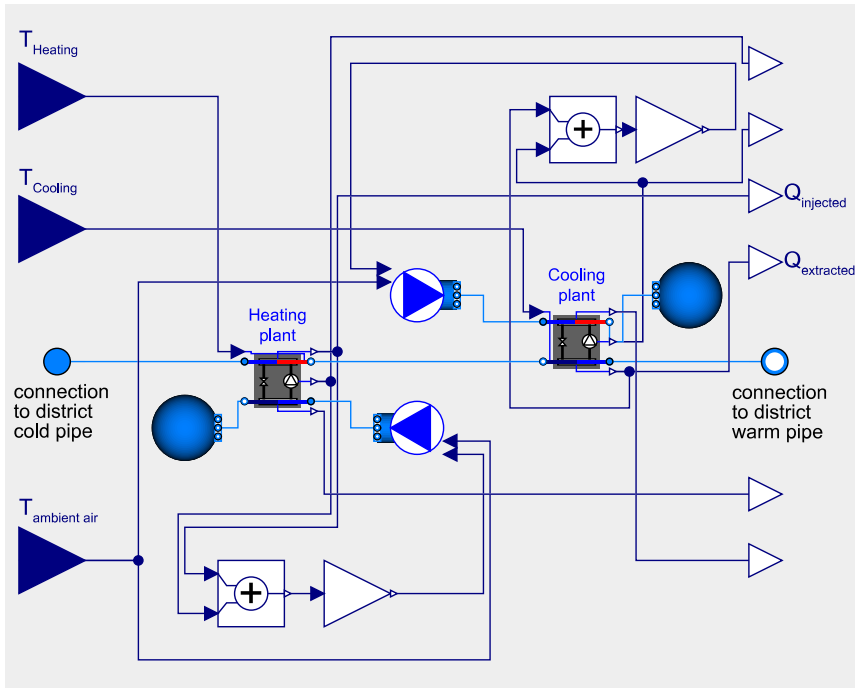
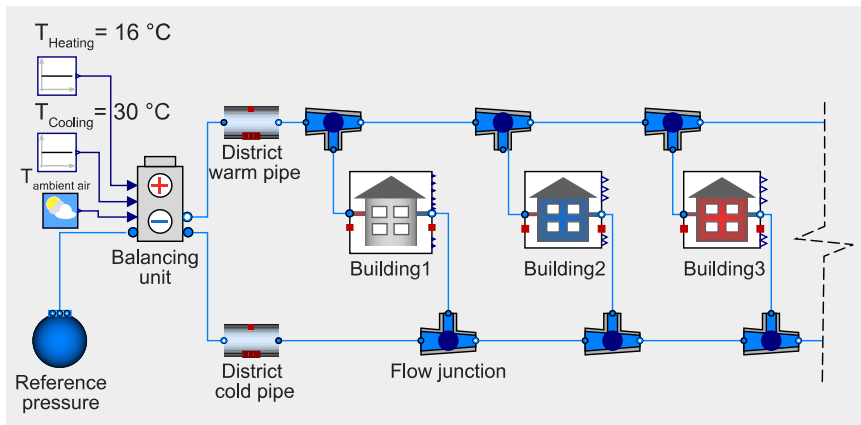

**Fig. 4.5** Diagram view of a balancing unit with heating and cooling plants. Curated variables shown in the diagram represent input temperatures and heat flows provided by the balancing unit.

In a heat injection mode, the air-source heat pump presented as *Heating plant* in Fig. 4.5 transfers thermal energy from the low-temperature air source to the high-temperature network sink. On the contrary, the air-source chiller shown as *cooling plant* removes heat from the district pipe and rejects it to the ambient air in a heat extraction mode. The model can be adapted to include a ground-source heat pump with boreholes heat exchangers. The balancing unit presented here does not include thermal energy storage which can reduce the amount of energy provided by the reversible air-source heat pump.

## 4.7 Model for 5GDHC district systems

The previous sections demonstrated a hierarchical modelling approach for the different components included in a fifth-generation district heating and cooling grid. The assembly of these components to compose the grid is realised by connecting the model icons. Fig. 4.6 shows a small grid consisting of three buildings. The grid can be expanded beyond the dotted line shown on the right side. The example shown here is intended to demonstrate how components are connected. Starting from the left direction, network heating and cooling setpoints and ambient air temperature are defined as inputs to the balancing unit. The network reference pressure is defined in the model represented in the blue circle. The balancing unit injects/extracts heat into/from the network according to the process explained in Section 4.6. The warm and cold pipe models represent a bidirectional pipe network. The split of flow occurs at the flow junctions which demonstrate the change of flow direction. At this stage, the benefit of the acausal modelling approach offered by Modelica becomes more prominent. The model of the complex 5GDHC system shown in Fig. 4.6 does not require explicit specification of the input/output relationships between system components. The Modelica code generator is responsible for determining the input and output variables that yield an optimal solution sequence.



**Fig. 4.6** Diagram of a model representing a fifth-generation district heating and cooling grid. To enhance appearance, only three buildings are shown.



## 5 Case Study

This chapter presents a case study used to model a fifth-generation district heating and cooling system. The case study consists of 11 buildings located in Lund (55° 42'N 13° 11'E), Sweden. The classification of buildings in terms of energy demands and space use is first provided. The subsequent section is devoted to explaining the retrieval of heat meter data. A metric used for mapping potentially promising building clusters is then discussed. A description of the simulation cases performed on the 11 buildings and modelling assumptions are then provided.

### 5.1 Classification of buildings

A map of the studied 11 buildings is shown in Fig. 5.1. The buildings were built in different years. The oldest was built in the 1970s and the newest was building 10 which was built in 2019. Some of the old buildings were renovated to improve their energy performance. The measured annual energy demands in 2015 in each building are shown on the two choropleth maps in Fig. 5.1. The use of choropleth maps at an early design stage of district systems allows to roughly estimate the total heat and cool supply from the network. In the context of 5GDHC networks, choropleth maps created based on the building's annual heating and cooling demands allow estimating the potential for demand balancing between possibly connected buildings.

Table 5.1 provides more description about the use of spaces in the studied 11 buildings that provide more insights into the building energy demands. For example, choropleth maps (B) and (C) show that building 6 has the highest annual heating and cooling demands. This can be explained by the different space usage in the building. About 42 % of the building's floor area is designated for offices, conferences, and lab work. These spaces have special requirements for heating and cooling to achieve indoor thermal comfort.

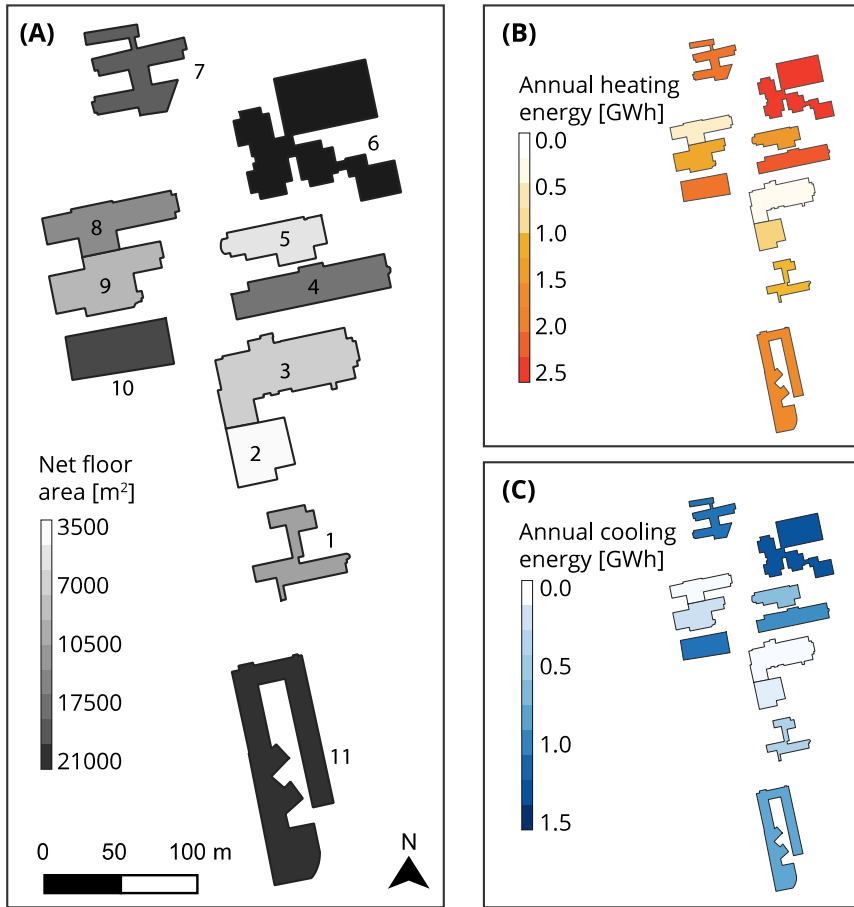

**Fig. 5.1** Choropleth maps of the studied 11 buildings based on: net floor area (A), annual heating energy (B), and annual cooling energy (C). Presented annual energy demands are collected from measurements in 2015. The maps were created using QGIS software for the analyses of geospatial data (QGIS, 2020).

The buildings were initially connected to a conventional district heating and cooling network before a change to a new 5GDHC network. The work of connecting the buildings to a 5GDHC network is currently in progress. There are now seven buildings connected to the 5GDHC grid. These are buildings 2, 3, 6, 7, 8, 9, and 10. All 11 buildings are planned to be connected to the 5GDHC network by the end of construction work. The buildings were all considered during the design stage of the network, thereby the sizing of system components is based on the expected total operating capacity to fulfil the heating and cooling demands in the 11 buildings.



**Table 5.1** Description of space use in the 11 studied buildings based on data during operation.

Building	Space area [m <sup>2</sup> ]						Net area [m <sup>2</sup> ]
	Office	Conference	Lab	Gym	Restaurants	Others*	
1	2214	1198	0	0	0	2584	5996
2	0	0	0	0	3800	0	3800
3	0	0	0	4176	0	0	4176
4	990	1138	2217	0	0	3972	8317
5	457	448	1523	0	0	1482	3910
6	1939	2625	4102	0	0	11967	20633
7	1395	2459	1601	0	0	4888	10343
8	626	1895	837	0	0	3673	7031
9	467	707	1125	0	0	3555	5854
10	17000	**	**	**	**	**	17000
11	5923	3706	0	0	0	9066	18695
Total	31011	14176	11405	4176	3800	41187	105755

\*Spaces classified as ‘others’ include services, circulation areas, and vertical penetration.

\*\*Building 10 was under construction during the investigation and we were, therefore, unable to anticipate how the building interior spaces will be used during operation. The building total floor area was assigned to office spaces since they constitute the main expected use of the building.

## 5.2 Acquisition of heat meter data

The acquisition of measured buildings energy demands plays a substantial role in modelling and simulating 5GDHC systems due to the sharing of energy flows between buildings. Chapter 4 demonstrated the interactions between component models in a 5GDHC system. These interactions start at the substation level where hourly annual heating and cooling demands were used to simulate the performance of heat pumps and chillers in the decentralised substations. Therefore, extra care should be given during data acquisition from heat meters to model the interactions between components accurately. The legislation stated in the Energy Efficiency Directive of the European Commission requires final consumers to have energy meters that are used for billing based on consumption (European Commission, 2011). Energy meters include meters for electricity, gas, heating, cooling, and domestic hot water. Mazhar et al. (2018) covered the subject of heat meters in the operation of district heating systems in their review study. They explained the three components which a typical heat flow meter consists of. These components include a flow meter, temperature sensors at inlet and outlet, and a

programmable calculation unit. The latter component will be the scope of the following paragraphs since it calculates the measured energy based on readings from the temperature and flow sensors.

Power is computed from the measured temperature and flow. Energy is calculated by integrating the powers over time. The reported energy has a minimum resolution that depends on the size of the meter. Small heat meters have a minimum resolution down to Wh, while large heat meters can go up to kWh and MWh. For practical reasons, reported energy is not always identical to what is measured internally in the programmable calculation unit. The first reason behind this is related to the billing which takes place over relatively long periods. Thus, making it unnecessary to report low and high resolution since the next report period compensates the difference in energy consumed in the previous period. The internal measurement accuracy of the meter guarantees a correct amount of reported energy over time, hence differences in reading periods are compensated. Another reason why low and high energy resolution is not reported is related to the M-bus communication system in thermal energy and water meters (European Standard, 2018). In this communication system, the display on the meter and pulse output usually have the same resolution. If we were to report low energy resolutions down to Wh, a large number of digits in the display would require large data storage. Moreover, the pulse output would be extremely short yielding unreasonable readings. For these reasons, the amount of energy is communicated via M-bus to the building management system once per hour.

Up to this point, the influence of the size of heat meters has been clarified. Heat meters of large size are installed in the 11 buildings introduced in Section 5.1. This entails that the meters have high accuracy reporting large hourly energy consumption measured in kWh. However, it becomes problematic for large size meters to report low hourly energy consumption in Wh. We will consider for example a heat meter that reports 50 kWh of energy use for a particular building at a given hour. In the next two hours, the heat meter reports zero energy consumption and at the third hour, it reports 50 kWh. In this case, it is more probable that the building had low energy consumption during the two hours with zero energy consumption where the heat meter did not report due to its large size. Therefore, one may need to process the measurements from heat meters to create more representative demand profiles that can be used for designing 5GDHC systems. During the processing of the measurements from the buildings included in the case study, the heating or cooling demand at any hour was equal to the average of the

readings from four consecutive hours. This means that in the previous example with readings equal to 50, 0, 0, and 50 kWh, each hour corresponds to a demand of 25 kWh after processing. This approach is based on engineering experience gathered from technicians and operators of the 11 buildings included in the case study. The demand profiles presented in Section 6.1 are based on this approach and can change when different data processing approaches are adopted.

Data processing should also consider peak demands and the distribution of energy consumption over time. This becomes increasingly important for applications similar to fifth-generation district heating and cooling systems. The explanation of the operating principles of 5GDHC systems provided in Section 3 emphasises the importance of processing heating and cooling energy consumption. This is because in 5GDHC systems heating and cooling demands are balanced first within the building and second between the connected buildings. The more representative the data is at each hour step, the higher the confidence in the predicted balanced energy is.

### 5.3 Assessment of building clusters

There are several metrics reported in the literature that can be used to find potential promising building clusters for 5GDHC systems. The metric *diversity index* has been used in appended Paper II to evaluate the performance of the 11 buildings included in the case study. The metric was evaluated for each building and the cluster through annual simulations. The metric, however, has the drawback that it cannot be interpreted in a physical sense. Wirtz et al. (2020b) also argue the same about the lack of physical meaning in the diversity index and therefore proposed another metric called *Demand Overlap Coefficient* (DOC). The assessment of the studied buildings based on the DOC is demonstrated in this section.

The DOC can be calculated at the following three levels: the district, the substation, and the network. The district DOC can be easily quantified at the early design stage since only building heating and cooling demands are required. A DOC with a value of 0 implies a complete absence of balancing potential, while a DOC of 1 means that demands are exactly balanced. The district DOC based on Wirtz et al. (2020b) is expressed as:

$$\Phi_{district} = \frac{2 \sum_{t \in \mathcal{T}} \min(\sum_{b \in B} \dot{Q}_h, \dot{Q}_c)}{\sum_{t \in \mathcal{T}} \sum_{b \in B} (\dot{Q}_h + \dot{Q}_c)} \quad \text{Eq. 5.1}$$

To be able to quantify the DOC at the substation level, the reader is reminded of the formulation of substations demand balance presented earlier in Section 3.2. The substation includes the Building Energy System (BES) with installed heat pumps, chillers, and direct cooling heat exchangers. The formulation shows that the demand balance in 5GDHC depends mainly on network temperatures that impact the performance of the BES. For a substation with an installed heat pump and chiller, the DOC is equivalent to:

$$\Phi_{BES} = \frac{2 \sum_{b \in B} \sum_{t \in \mathcal{T}} \min\left(\dot{Q}_h \left(1 - \frac{1}{COP_{HP}}\right), \dot{Q}_c \left(1 + \frac{1}{COP_{CH}}\right)\right)}{\sum_{b \in B} \sum_{t \in \mathcal{T}} \left(\dot{Q}_h \left(1 - \frac{1}{COP_{HP}}\right) + \dot{Q}_c \left(1 + \frac{1}{COP_{CH}}\right)\right)} \quad \text{Eq. 5.2}$$

The term  $\dot{Q}_h \left(1 - \frac{1}{COP_{HP}}\right)$  denotes the heat flow in the heat pump evaporator, while the term  $\dot{Q}_c \left(1 + \frac{1}{COP_{CH}}\right)$  represents the heat flow in the chiller condenser. In substations where direct cooling is realised, Eq. 5.2 can be easily adapted according to the demand balance explained previously in Eq. 3.1.

The excess heat from either the heat pump evaporator or the chiller condenser flows into the pipe network to be exchanged with other buildings. Wirtz et al. observed a correlation between the DOC at the three different levels in the system, which is expressed as:

$$(1 - \Phi_{network})(1 - \Phi_{BES}) \approx (1 - \Phi_{district}) \quad \text{Eq. 5.3}$$

Quantifying the three levels of DOC on the studied buildings provides more understanding of the demand structure within and across buildings. The metric can also support the planning of future network expansion to assess the contribution of each building on the amount of balanced energy.

## 5.4 Simulation cases

The studied 11 buildings were simulated for two different design cases to investigate several aspects of the system. These aspects include substation performance, balancing unit performance, network temperature oscillation,

total system electric energy consumption, and system waste heat to ambient air. In Case 1, only a heat pump and a chiller are installed in the substation. The waste heat from the chiller condenser acts as a source to the heat pump evaporator inlet. Similarly, the heat pump evaporator outlet serves as a cold source to the chiller condenser inlet. Depending on the quantity of heating and cooling demands at a given point in time, heat is either extracted or rejected from/to the network. On the other hand, Case 2 includes the heat pump and the chiller in addition to a heat exchanger used for direct cooling. The direct cooling heat exchanger reduces the operation time of the chiller, and thus, decreasing the compressor electric power. However, it also decreases the potential to recover waste heat from the chiller which in turn influences the performance of the heat pump. Performing annual simulations on the two cases allows investigating the aspects mentioned earlier.

Sensitivity analyses of the network heating and cooling setpoints were carried out on Case 2 to evaluate their impact on the following three indicators: the annual energy provided by the balancing unit, the annual waste heat to ambient air, and the annual total system electric energy consumption. The simulation environment Dymola supports sweeping parameters for several points between a minimum and maximum predefined range. The two parameters representing the setpoints for warm and cold pipes are presented in Fig. 4.6 with values of 16 and 30 °C, respectively. The range for the heating setpoint was defined between 10 and 20 °C, while for the cooling setpoint the range was between 30 and 40 °C. The reason for choosing these ranges is that a few 5GDHC systems have been reported with operated network temperature below 50 °C (Lund et al., 2021). Therefore, we adhered to this operating limit by maintaining a maximum temperature of the cold pipe at 40 °C. This limit, together with the assumed temperature difference of 10 K between the warm and cold pipes, satisfies an operating temperature below 50 °C throughout the year. The number of points in each range was set to 6 points, meaning that a new parameter value is defined at an interval of 2 °C. Because the sensitivity analyses are carried out on two parameters each with 6 points, the number of required simulations is therefore equivalent to 6×6 simulations. Parameters together with their ranges need only be defined once and Dymola would be able to run automated simulations and store the simulation results.

## 5.5 Assumptions and design parameters

During investigating the buildings included in the case study, building 10 was under construction and it was not possible to retrieve measured heating and cooling demands in the building. It was assumed that building 10 has similar demands to those of building 7 since the latter has demand profiles that are much likely to be representative of the new building.

For building energy systems that are realised in substations, three assumptions were made. First, the pinch temperature between refrigerant and water outlet in condensers and evaporators was set to 2 K, which is a typical value used also in literature (Zarin Pass et al., 2018). Second, the temperature difference between the inlet and outlet of the condensers and evaporators was assumed to be constant at 10 K to maintain the same temperature difference between the district warm and cold pipes. The value of the temperature difference is based on the network design and actual operation of the system. However, temperature control and optimisation were not covered in this research. Third, the Carnot efficiency of heat pumps and chillers was assumed to be 50 %, and the global efficiency of circulation pumps was set to 49 %, which are typical design values and also used by Sommer et al. (2020).

On the district side, the temperature setpoints for network heating and cooling were 16 and 30 °C. Since heat pumps and chillers operate at a constant 10 K temperature difference at their district connection side, the network setpoints constrained the temperature in the warm pipe to be in the range 16-40 °C, and in the range 6-30 °C in the cold pipe. A more comprehensive list of design parameters can be found in appended Paper III.

# 6 Case Results and Discussion

A major part of the results chapter is dedicated to the comparison between the two simulated cases performed on the studied 11 buildings. Case 1 consists of a substation with installed heat pumps and chillers, while Case 2 includes an additional heat exchanger used for direct cooling. The comparison is presented based on the annual Seasonal Coefficient of Performance for substation energy systems, the annual energy provided by the balancing unit, and the annual network temperature oscillation. A summary of the comparison between the two simulated cases is then provided in terms of supply-demand structure at different system levels. The chapter also presents the results of the sensitivity analyses aiming to evaluate the impact of network setpoints on several key indicators. Moreover, the chapter presents and discusses the computational time required in each simulation setup. The chapter closes with a presentation of ethical risk analyses of the different personal and organisational roles that may arise in 5GDHC business models.

## 6.1 Rapid prototyping of models developed in Modelica

Employing the Modelica language for the modelling and simulation of the fifth-generation district heating and cooling is motivated given the following language features: 1) convenient multi-domain modelling using a free open-source object-oriented language, 2) reduced modelling time and reduced modelling errors by inheriting existing robust and validated models from finished libraries, 3) possibility to edit the source code to adapt changes in the model use, and 4) visual assembly of large physical systems in a hierarchical modelling approach. The Modelica *Buildings* library was chosen in this study

due to the available wide range of components from the building domain. Moreover, the library includes plenty of examples and validations for different component configurations. The contents of the Modelica *Buildings* Library and documentation of all included models can be browsed online from reference (Berkeley Lab, 2021).

The decomposition of the large 5GDHC system into smaller components was demonstrated in Section 3.1. Existing component models in the Modelica *Buildings* library were reused or edited to develop a model for the 5GDHC system based on the case study presented in Section 5. For example, the available library components for the heat pump, the circulation pump, and the heat exchanger have been used to assemble models for substations with different types of thermal demands. Components for bidirectional pipes and flow junctions were used to connect the substations and the balancing unit to a simple bidirectional pipe network. We are aware that aspects related to model uncertainty and model validation have not been covered at this part of the research. However, the developed model establishes the base work for future research where additional components for network temperature control will be incorporated and where empirical validation will be carried out. The rapid prototyping of models developed in Modelica facilitates future research and enables quick adaption of system design changes.

## 6.2 Cluster demand profiles

The annual cumulated demands in the cluster consisting of the 11 studies buildings are presented in Fig. 6.1. The cluster has simultaneous demands for heating and cooling throughout the year. The hourly demand profiles offer some insights into the potential demand balancing between buildings. The annual energy demands previously presented in Fig. 5.1 can be seen as the first selection stage of potential buildings. During the first selection stage hourly resolution of heating and cooling demands are not required. The hourly resolution shown in Fig. 6.1 supports evaluating the Demand Overlap Coefficient (DOC) at three system levels. Table 6.1 shows the derived DOC for the two cases at the three different system levels. Because the cluster demands are the same in the two cases, no differences were observed in the value of the district DOC. On the substation building energy system and network levels, changes were negligible since both cases allowed demand balancing between the building energy systems. Wirtz et al. (2020b) concluded



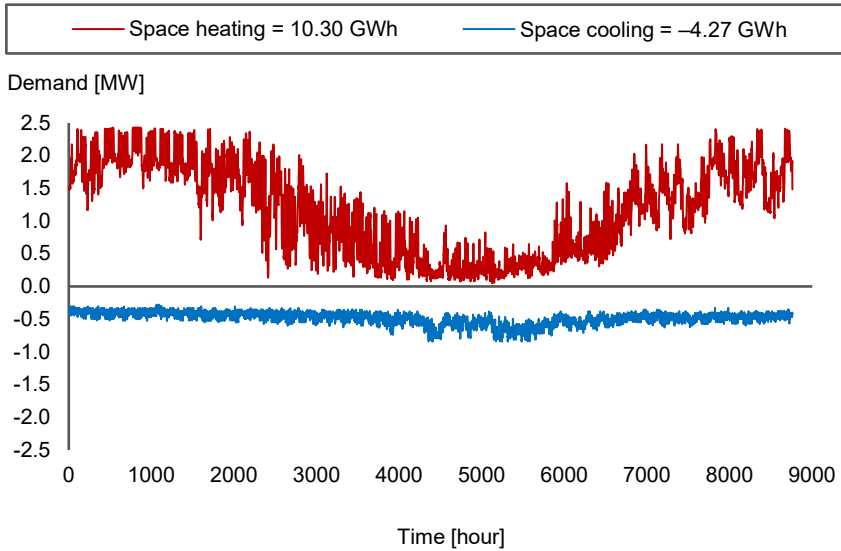

**Fig. 6.1** Annual cumulative heating and cooling demands in the studied cluster of 11 buildings. The abscissa shows the hour during the year and the ordinate shows the measured demand in 2015 in Megawatt.

that a cascaded district system with DOC larger than 0.3 has higher exergy efficiency compared to a non-cascaded system with individual energy systems. They also highlighted that the annual costs of the district system are lower than the non-cascaded system when the district DOC is higher than 0.45. Comparing the results shown in Table 6.1 with Wirtz et al. conclusions, the studied 11 buildings proved to be a beneficial investment for a 5GDHC district system.

**Table 6.1** Derived Demand Overlap Coefficient at three different system levels.

	Case 1	Case 2
$\Phi_{district}$	0.828	0.828
$\Phi_{BES}$	0.539	0.543
$\Phi_{network}$	0.627	0.624

### 6.3 Substation performance

As described earlier in Section 4.5, the model for substations consists of heat pumps, chillers, direct cooling heat exchangers, and circulation pumps. The

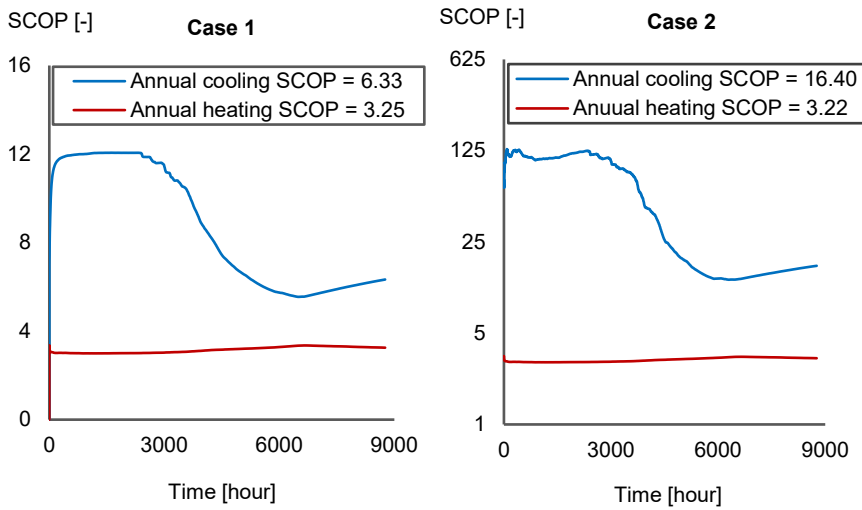

**Fig. 6.2** Variation of substation cooling and heating Seasonal Coefficient of Performance in the two simulated cases. Note that the two charts do not have a uniform scale.

heating and cooling Seasonal Coefficient of Performance (SCOP) for the two simulated cases are presented in Fig. 6.2. A detailed explanation of the SCOP derivation is provided in appended Paper III. The figure shows two important aspects of the performance of substation energy systems. First, it can be noticed that the heat pumps have a relatively low heating SCOP. A possible explanation for this is related to the assumed constant supply temperature throughout the year. Heat pumps in actual applications adjust the condenser leaving temperature based on the outdoor temperature and a control curve. In extremely low outdoor temperatures, the condenser leaving temperature is the highest. Lower temperatures are supplied by the heat pump as the outdoor weather becomes warmer. The assumed constant supply temperature forces the heat pumps to operate at higher temperature lifts than what is to be expected in controlled heat pumps. The control curves can be easily implemented in the heat pump models to reflect the actual behaviour of the system. The second aspect shown in Fig. 6.2 corresponds to the efficiency gain in the energy systems when direct cooling is realised. As heating demand dominates at the beginning of the year, the potential for demand balancing by the heat pumps increases. In this situation, the heat pump evaporator provides cooling through the direct cooling heat exchanger. Consequently, the cooling performance significantly increases as the compressor work in chillers is not required. By contrasting Fig. 6.2 against the demand profiles illustrated in

Fig. 6.1, one can see the drop in heating demand during spring while cooling demand remains almost unchanged. Because of the lower heating demand, the evaporator side of the heat pumps does not provide enough free cooling. Therefore, chillers operate to cover the rest of the cooling demand, which consequently decreases the cooling SCOP due to the compressor mechanical work. The presented annual SCOP confirms the association between direct cooling and improved system efficiency.

## 6.4 Balancing unit performance

The primary function of the balancing unit is to compensate for the network energy imbalance due to demand disturbances. The simulated balancing unit consists of heating and cooling plants that provide heating and cooling. Fig. 6.3. presents the energy and power delivered by the balancing unit in simulated Case 1 throughout the year. Because the two cases have similar

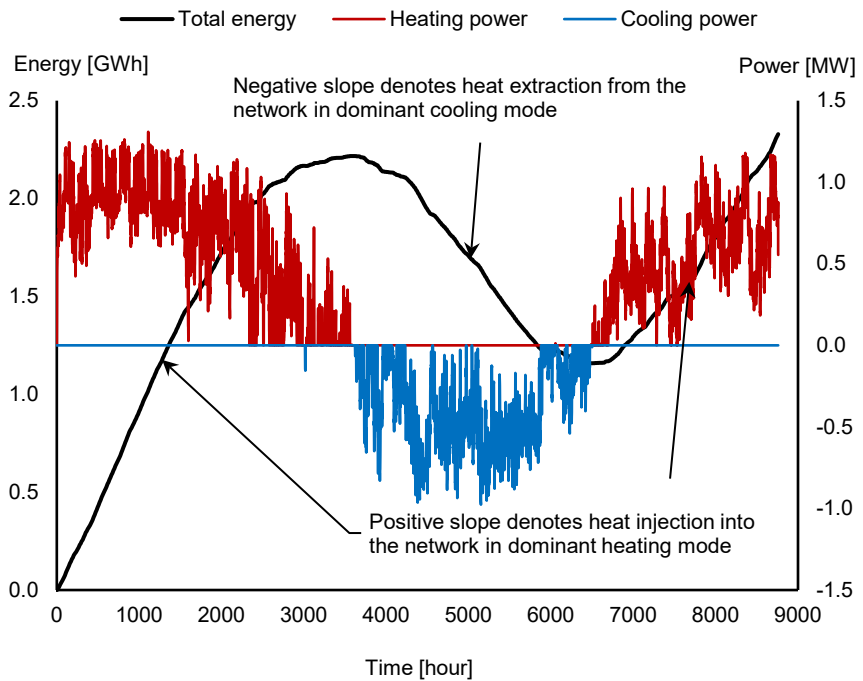

**Fig. 6.3** Hourly annual heat injection and extraction by the balancing unit for simulated Case 1. The abscissa shows the hour of the year, the left ordinate shows the energy in Gigawatt hours, while the right ordinate shows the power in Megawatt.

trends in terms of energy and power provided by the balancing unit, only Case 1 is presented. The balancing unit comparison between the two cases will be shown later in greater details in Section 6.5. In Fig. 6.3 one can see a continuous heat injection by the balancing unit into the network during the cold season and when heating demand dominates. This can be seen during the cold season in the positive slope of the black line representing the total provided energy. As cooling demand becomes larger during summer months, chillers in each substation provide cooling that results in waste heat from the chillers condenser. The waste heat is rejected to the network causing its temperature to rise. The balancing unit, therefore, extracts the excess waste heat by cooling the network. The heat extracted by the balancing unit is represented by the negative energy slope between the apex and nadir points in the summer months.

The energy provided by the balancing unit can be reduced by adopting a thermal energy storage system realised in a tank. The tank can store some of the excess waste heat and, thus, reducing the required cooling in the network. Moreover, the stored energy is utilised to deliver heating to connected buildings. The storage tank acts as a passive balancing unit compared to the heating and cooling plants, which can increase the system energy efficiency. Because the network temperature is indicative of the energy flows in the network, it can provide more insights into the potentials for implementing a storage tank. The next section provides more explanation about the network temperature oscillation throughout the year.

## 6.5 Network temperature oscillation

The fluid annual temperature oscillation in the warm and cold pipes in the two simulated cases is shown in Fig. 6.4. In both cases and when heating demand dominates at the beginning of the year, each substation heat pump draws water from the district warm pipe to the evaporator inlet at a temperature of 16 °C. The temperature difference between the evaporator inlet and outlet is assumed to be 10 K as previously mentioned in Section 5.5. Therefore, the outlet from the heat pump evaporator flows into the district cold pipe at a temperature of 6 °C. During this time of the year, no waste heat is observed because in Case 1 all the heat in the chiller condenser is balanced with the heat pump evaporator inlet. In Case 2, however, heat pumps can fully provide the required cooling through the direct cooling heat exchanger.

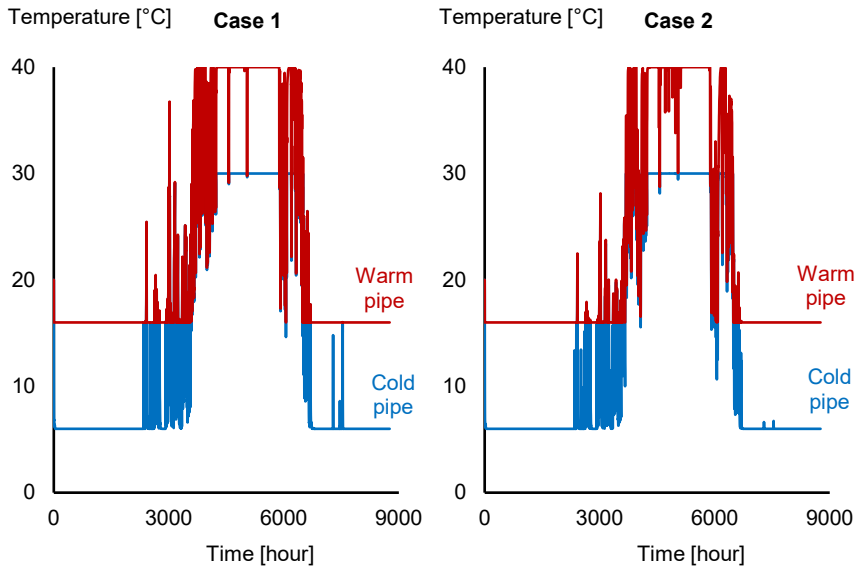

**Fig. 6.4** Annual network temperature oscillation in warm and cold pipes in the two simulated cases. The abscissa shows the hour during the year and the ordinate shows the temperature in degree Celsius.

Hence, the cold and warm pipes remain at respective temperatures of 6 and 16 °C during this period. Analysing the demands presented earlier in Fig. 6.1, it can be seen that the average heating demand drops by more than 50 % in spring. Subsequently, the chillers operate more frequently in both cases, and the effect of waste heat becomes obvious as the network temperature rises. This finding is confirmed by the negative line slope shown in Fig. 6.3, which represents the amount of extracted heat by the balancing unit. The network temperature reaches its maximum design limit when cooling demand dominates. The periods where the network temperature starts to rise indicate a potential for utilising thermal energy storage. Here, a storage tank can discharge the excess heat in the network by storing the available energy. The tank would charge the network with the stored energy once heating becomes dominant. Therefore, the tank reduces the operation time and the required capacity of the balancing unit heating and cooling plants.

A major distinction between the two cases is that direct cooling in Case 2 allows the warm pipe temperature to decrease more frequently and for longer periods during summer. This can be seen by contrasting the warm pipe temperatures between Case 1 and Case 2 during the summer season. This is to be expected since the amount of waste heat from the chillers condenser is

significantly lower compared to Case 1. One important aspect to consider in the presented network temperatures is that the pipe model does not take into account the thermal losses between the pipe and the ground. Since 5GDHC networks operate at low temperatures close to the ground temperature, it is expected that the thermal losses are quite small. However, a detailed evaluation of the impact of network thermal losses in 5GDHC systems is required.

## 6.6 District supply-demand structure

The previous sections in this chapter presented the performance of individual subsystem levels as a separate node in the district system. The exchange of energy flows between the different system levels impacts the performance of the district system. Therefore, a comparison between the two simulated cases at different system levels is now presented and shown in Fig. 6.5. On the substation level, Case 2 with direct cooling outperforms Case 1 where about 10 % savings in substation electric energy consumption was observed. On the network level, excess energy from the heat pump evaporator or the chiller condenser is rejected to the network to be exchanged with other buildings. The excess cold is larger in Case 2 since demand balancing between the heat pump evaporator and the chiller condenser happens less frequently when direct cooling is realised. Consequently, the excess heat from the chiller condenser in Case 2 is less by about 53 %. At this level of comparison, no particular case can be favoured against the other without considering the overall system performance. The amount of excess cold and excess heat in the network has a direct influence on the required amount of energy provided by the balancing unit. This can be seen in the third chart where additional heating is provided by the heating plant in Case 2 due to the excess cold in the network. Similarly, less cooling is provided by the cooling plant in Case 2 as excess heat in the network are significantly lower compared to Case 1. However, the amount of energy provided by the heating plant in Case 2 is larger than the amount of energy provided by the cooling plant in the same case by about four orders of magnitude. Consequently, the balancing unit electric energy consumption is 6 % higher in Case 2. Taken together, the results indicate that a total reduction of about 7 % of electric energy consumption can be achieved when direct cooling is realised. Moreover, implementing a direct cooling heat exchanger in each substation can reduce the waste heat from the balancing unit cooling plant by about 17 %.

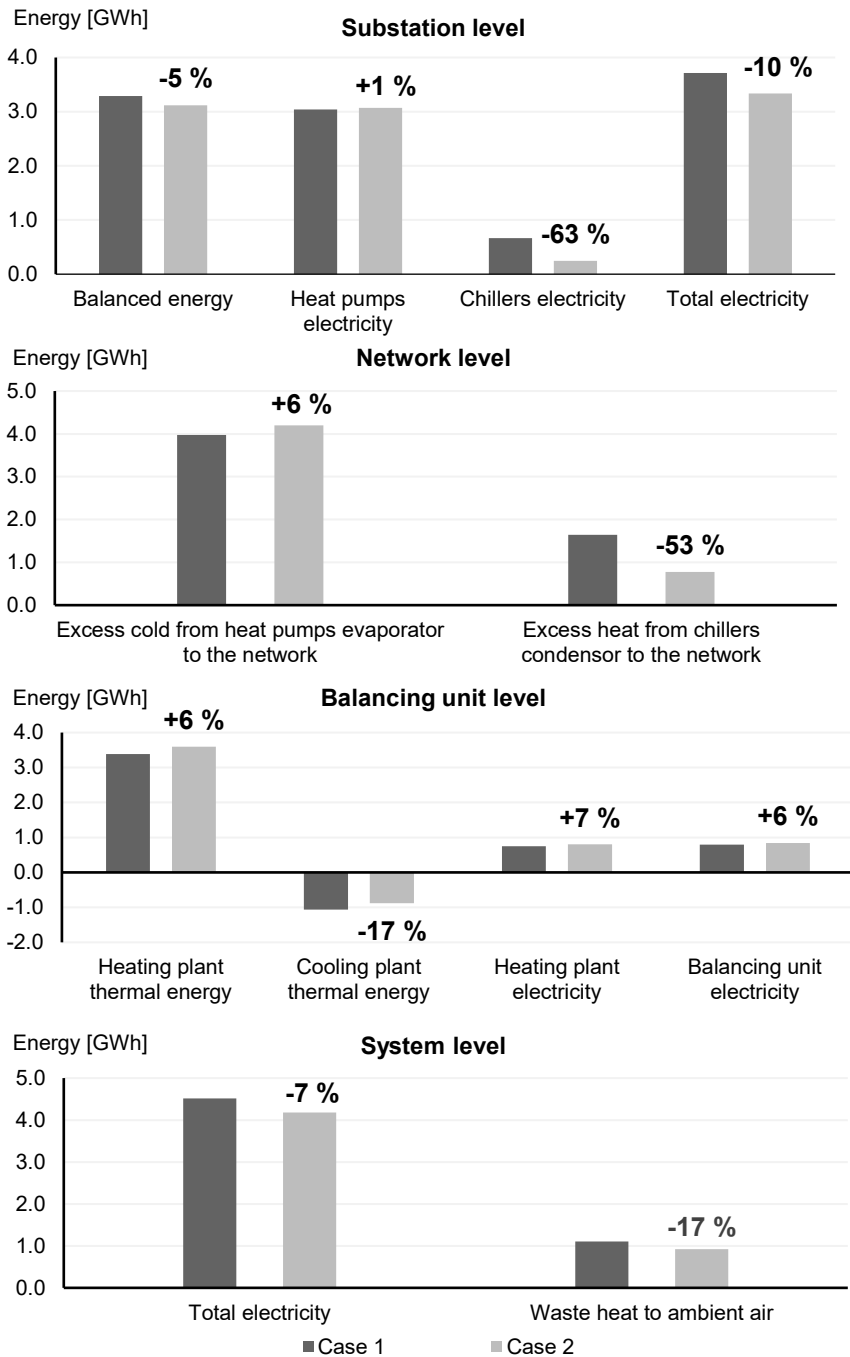

**Fig. 6.5** Categorisation of district supply-demand structure at four different levels in the two simulated cases. Overall, Case 2 with realised direct cooling reduces both electric energy consumption and waste heat.

## 6.7 Sensitivity analyses

The impact of network heating and cooling setpoints is illustrated in the contour maps presented in Fig. 6.6. The three maps show the impact of network setpoints on the annual energy provided by the balancing unit, the annual waste heat to ambient air, and annual total system electric energy consumption. A glance at the three maps shows that the cooling setpoint only impacts the amount of waste heat without significantly impacting the other indicators. Higher cooling setpoints reduces the amount of required heat extraction from the network. Thus, the cooling plant in the balancing unit operates less frequently, which results in lower waste heat from the cooling plant condenser to the ambient air. Increasing the cooling setpoint by 10 °C can reduce the amount of annual waste heat by up to 4 %. To recommend whether or not the cooling setpoint should be increased, an evaluation of the carbon emissions reduction and the corresponding life-cycle cost of the system would be required.

The first and third maps show that the heating setpoint directly impacts the energy provided by the balancing unit and the system total electric energy consumption. Because the studied cluster has dominant heating demand throughout the year, increasing the heating setpoint would require the balancing unit to inject more heating into the network. Therefore, the heating setpoint and the annual energy provided by the balancing unit are positively correlated. On the contrary, an inverse correlation is observed between the heating setpoint and the system total electric energy consumption. Again, this is associated with the dominant heat demands in the studied buildings. Decreasing the network heating setpoint implies that substation heat pumps would operate at larger temperature lifts, which in turn decreases the heat pumps COP. The differences in the system total electric energy consumption with varying heating setpoint are however infinitesimal. Thus, the other two indicators should have more weight when choosing optimal network heating and cooling setpoints.



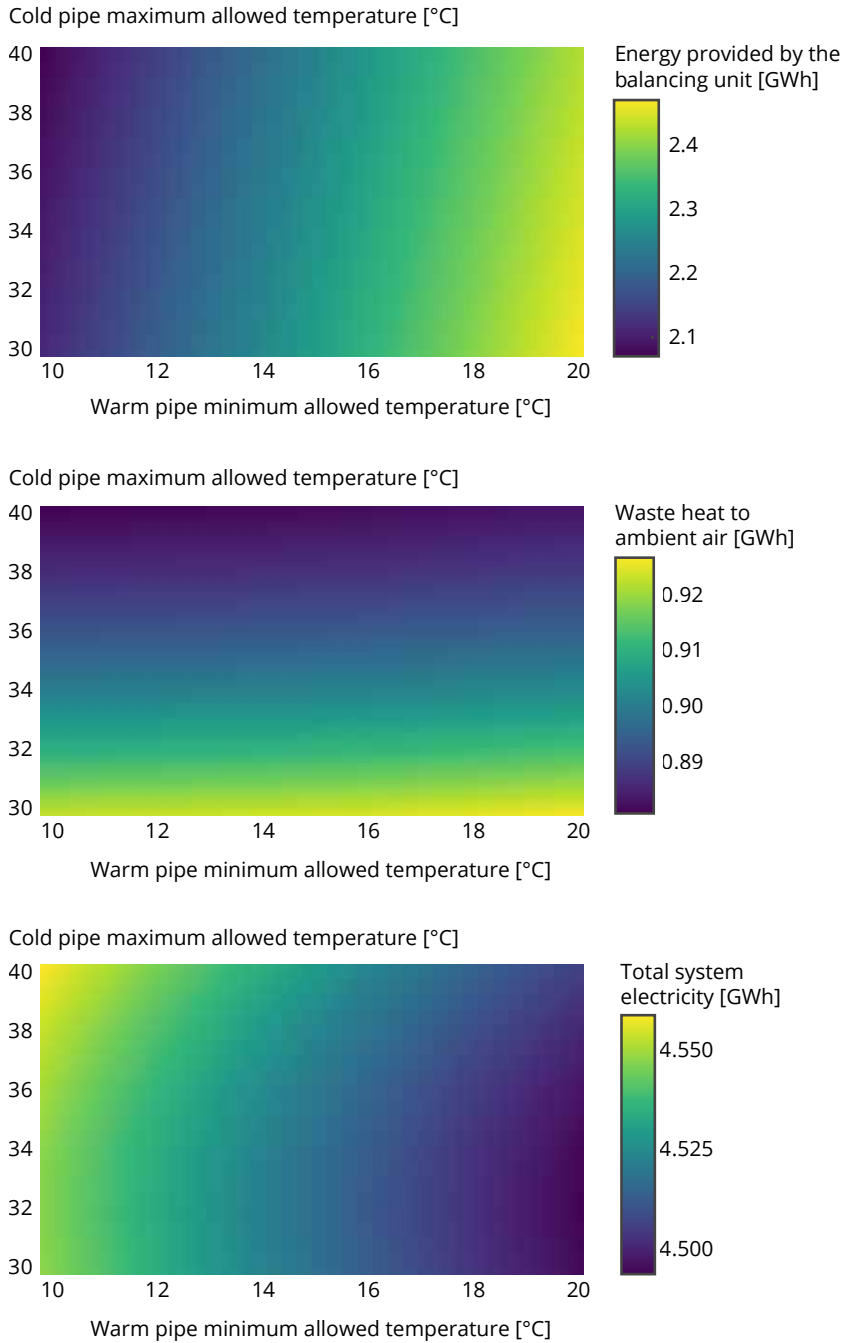

**Fig. 6.6** Impact of pipe network setpoints on: annual energy provided by the balancing unit, annual waste heat to ambient air, and annual total system electric energy consumption.

## 6.8 Simulation performance

The performance of district energy systems simulation in Modelica was discussed extensively in appended Paper I. The simulation information and performance for the two simulation cases developed in Modelica are provided in Table 6.2. The table provides a distinction between the two simulation cases and when the sensitivity analyses were carried out. All simulations were performed on a desktop computer with 12 physical cores and 24 logical processors with a maximum speed of 3.50 GHz (AMD Ryzen Threadripper 2920X) and 32 GB of RAM running under Windows 10 Pro 64 bit. Dymola version 2020x was the Modelica simulation environment and the selected integration algorithm was the Differential Algebraic System Solver (DASSL). One can see that adding components for direct cooling heat exchanger increased the number of model equations by about 17 %. Subsequently, the required CPU time increased by about 20 %. The reader is reminded that these changes were observed when simulating a small grid of 11 buildings. As more buildings become connected to the grid, the simulation time can increase significantly. In the simulation experiments published in the final report of IEA EBC Annex 60, the simulation time increased by a factor of 3.45 when the number of connected buildings doubled from 3 to 6 (Wetter & Van Treeck, 2017). The factor was about 1.9 when co-simulation was leveraged. It is therefore recommended for future studies to simulate district heating and cooling systems using Modelica and FMI for co-simulation.

**Table 6.2** Simulation information and performance for a 5GDHC grid with 11 connected buildings.

Simulation Case	Environment	Integration algorithm	Tolerance	Number of equations	CPU time [s]
Case 1	Dymola	DASSL	$1 \times 10^{-6}$	10 154	142.9
Case 2	Dymola	DASSL	$1 \times 10^{-6}$	11 877	169.6
Sensitivity analyses	Dymola	DASSL	$1 \times 10^{-6}$	*	467.8

\*The sensitivity analyses were carried out on Case 2 by sweeping parameters as explained in Section 5.4

## 6.9 Ethical risk analyses

The intrinsic synergies in the fifth-generation district heating and cooling systems offer the possibility to share energy flows between connected buildings. Although this synergy can create significant environmental and

social benefits, it can also create conflict between connected customers if the roles of each customer are not clearly defined. To better understand the expected role of each customer in the fifth-generation, a comparison between the business models in 5GDHC systems and conventional district heating systems is first presented. Conventional district heating realised in the third generation still dominates the district heating market where the business model already generates profits for district heating companies. Lygnerud (2019) provides the features of conventional district heating business models which are presented in Table 6.3. Unlike the clear distinction between the customer and the district heating company sides shown in the table, 5GDHC business models do not necessarily provide the same clear distinction. This is attributed to the fact that the fifth-generation connects prosumers who are producers/consumers of energy towards/from the network. The business logic in the conventional district heating systems depends on a strategy of push (heat supply) rather than pull (market demand). In 5GDHC systems, the strategy is based on the balance between inhale (heat extraction) and exhale (heat injection). Moreover, prosumers can become the owners of the grid in communities that prefer to have autonomous heat and cold supply. These changes in the business model structure change the classification of the different customers and their distinctive role(s). This can create hidden ethical risks which need to be analysed.

**Table 6.3** The features of the conventional district heating business model. Adopted from Lygnerud (2019).

Customer side		In-house (district heating company) side	
1. Customer value	Heat and hot water	1. Key activity	Production Distribution Maintenance
2. Customer segment	Large building owners	2. Key resources	Production unit Distribution network
3. Customer relationship	Provider to consumer	3. Key partnership	Fuel providers
4. Customer channel	Invoice, campaigns	–	–
5. Income structure	Fixed	4. Cost structure	Large fixed costs

Fig. 6.7 presents a virtual business model in a 5GDHC network with an energy bank. The presented network adopts a few modifications to the bidirectional network with agent-based control reported in literature

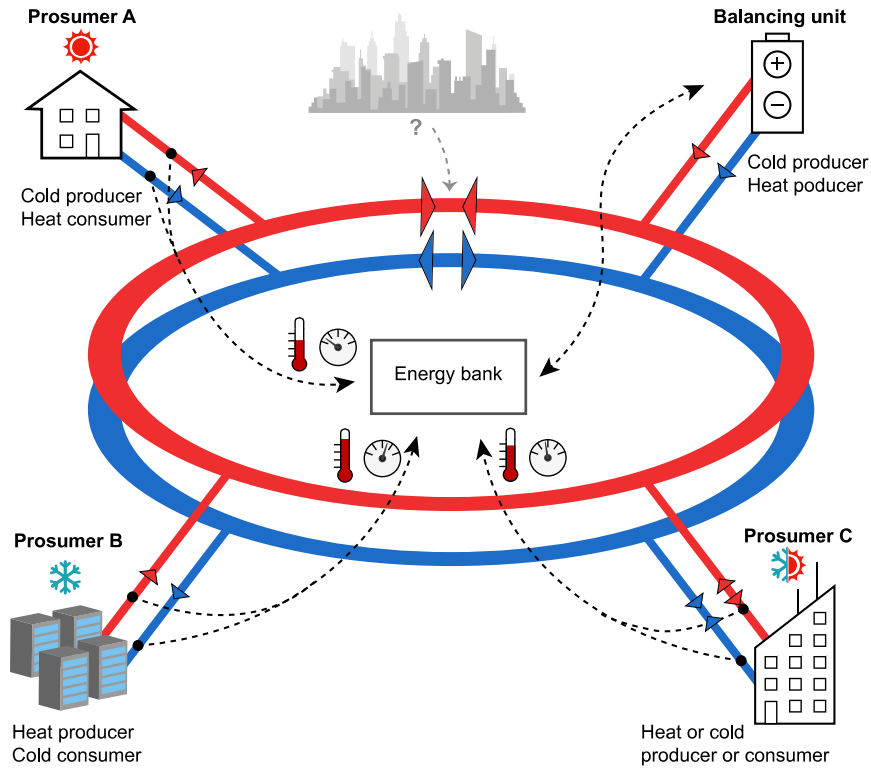

**Fig. 6.7** A virtual business model in a fifth-generation district heating and cooling network with an energy bank. The energy bank first quantifies the contribution of each prosumer to the network energy balance and then estimates the corresponding invoice energy price for each prosumer.

(Bünning et al., 2018) to fulfil the purpose of this analyses. The energy bank quantifies the contribution of each prosumer to the network energy balance by measuring the mass flow and temperature of the produced and consumed energy. The energy price for a particular prosumer is estimated by the energy bank depending on the contribution of that prosumer. Prosumer A consumes heating from the network and transfers it by the local heat pump to the building sink. Consequently, Prosumer A produces cooling to the network after the energy has been transferred. Similarly, Prosumer B consumes cooling from the network where the local chiller produces heating to the network. Depending on the type of dominant demand, Prosumer C can have either kind of contribution at any given point in time. The energy bank communicates with the balancing unit to provide the required energy to achieve network energy balance. Each prosumer pays for the estimated energy price when their contribution results in more energy supply by the balancing

unit. Conversely, prosumers can generate profit when their contribution benefits the network balance without the need for the external balancing unit.

The previous tasks performed by the energy bank put the bank under a questionable role by the connected prosumers. For example, the energy bank may offer more possibilities to certain prosumers to generate more profit than others. Moreover, a prosumer such as a data centre is more likely to be charged with a relatively higher energy price in summer while it can generate profit in winter. The reason behind this is related to the continuous heat production by the data centre towards the network throughout the year. Deciding the appropriate energy price must therefore involve the other prosumers who used to pay in winter and started generating profit in summer. Another questionable role by the bank is found when the network undergoes a future expansion. Here, the energy bank may have a selection bias to favour buildings that contribute to the network energy balance more than others. This situation stirs questions about the intrinsic value of district energy systems and whether they are built for efficiency or for community resilience that tackles energy poverty. From the three-role combinations proposed earlier by Hansson (2018), the ideal situation for the energy bank can be found when the bank is owned and operated collectively by all prosumers. Alternatively, the energy bank can be an independent organisation that represents all prosumers while at the same time it provides transparent energy price models to all existing and possible prosumers. This can help avoid any potential ethical risk due to problematic role combinations.

Overall, the technology behind the fifth-generation seems to offer many potential benefits for societal development as well as for the environment. Further engagements in engineering ethics education ensure the safe operation of these systems and can also help shed more light on their key values.



# 7 Conclusions and Future Research

## 7.1 Conclusions

This dissertation demonstrated equation-based object-oriented modelling and simulation of fifth-generation district heating and cooling systems. The approach employs Modelica as the modelling paradigm due to its higher flexibility in managing models of large complex physical systems. It has been shown how inheriting and editing existing component models allow rapid virtual prototyping of different models for several design configurations of 5GDHC systems. Models of two distinctive substation design cases were developed and the corresponding system performance was evaluated. Despite their limitations, the models certainly add to the understanding of the mechanism of sharing energy flows between system components and across connected buildings.

It was observed that including a direct cooling heat exchanger in each substation reduced the annual total system electric energy consumption up to 7 % in the studied case. Moreover, the study revealed a direct association between lower district cold pipe setpoints and increased annual system waste heat to ambient air. On the other hand, lowering the district warm pipe setpoint from 20 to 10 °C yielded a 16 % reduction in the annual energy provided by the balancing unit.

The applicability of the developed models has several practical implications that are divided here into three distinct areas. First, the models support the planning of 5GDHC systems by applying a quick search for potential building clusters. In this stage, metrics are evaluated to quantify the potential for demand balance between studied buildings. By demand balance, we imply the ability of the district system to recover waste heat from cooling processes that

involve compressor work. The recovery of waste heat consequently reduces carbon emissions and primary energy demands.

The second practical implication is realised by exploiting the models to optimise the system design and operation. Because models developed in Modelica are simulated in the continuous-time domain, engineers can perform numerous experiments with different input design parameters. Thermodynamic and hydraulic analyses of each experiment provide deeper insights into the system performance. Engineers can dimension the pipe network and size building energy systems and the balancing unit based on the output of the continuous-time simulations.

Another practical implication of the models is the possibility to investigate new business and price models emerging from fifth-generation technology. For example, buildings with continuous cooling demand throughout the year offer more efficiency gains to the district system in the winter season than in the summer. A unit energy price for each building is predicted based on the building contributions to the network energy balance. Whether or not these new business models may influence the behaviour of building occupants to prioritise lower energy cost over energy savings remains to be elucidated.

Greater efforts are needed from engineers, decision-makers, and all involved in research on 5GDHC systems to engage in ethical discourse that guarantees safe and transparent implementation of the technology.

## 7.2 Future research

The dissertation lays the groundwork for more detailed research into fifth-generation technology. The following three research areas will be investigated during the second half of the PhD project.

### *7.2.1 Model calibration and empirical validation*

Model calibration involves the manipulation of parameter values so that model predictions fall within a reasonable range from the observations. The case study presented in this dissertation includes several buildings that have been connected to the 5GDHC system and are currently in operation. Measured data about system performance are currently being collected for empirical validation. Temporal and spatial variations of physical quantities such as energy and mass will be used to calibrate the model predictions against the measurements. This work facilitates real-time system operation and enables a more accurate and quick investigation of future network expansion.



### 7.2.2 *Templates for balancing units*

The balancing unit can have several design choices that include different energy systems and energy sources. Examples of different energy systems may include reversible heat pumps, thermal energy storage tanks, gas-fired boilers, and the utilisation of existing district heating and cooling networks to cover peak demands. On the other hand, energy sources can be fully renewable or a combination of renewable and non-renewable sources. Examples of renewable energy sources include geothermal, solar thermal, and biofuels that are regarded as renewables. Non-renewable energy sources include coal and refined oil products. Part of the future work aims to analyse different design cases of the balancing unit. Based on the geographical criteria of the modelled 5GDHC system, templates for pre-configured models of balancing units will be provided. Furthermore, balancing units can incorporate a thermal energy storage system used for passive balancing. Another part of the future work aims to investigate the impact of different sizes of thermal energy storage tanks on the demand balance and life-cycle cost of 5GDHCS networks.

### 7.2.3 *Network temperature and pressure control strategies*

The network model presented in this dissertation incorporated a straightforward free-floating temperature control strategy. A future research area will focus on comparing different network temperature control strategies and their impact on the system performance. One proposed temperature control strategy is based on real-time optimisation of both warm and cold pipes to lower the operation costs. Another, yet more simplified, temperature control strategy forces one pipeline to have constant temperature throughout the year while allowing the temperature in the other pipeline to float. Network demand structure decides the suitable temperature control strategy, hence future recommendations will be provided after studying different demand scenarios.

Pressure control ensures safe network operation and maintains the desired energy flows at each end-customer. Hydraulic imbalances in the network occur due to demand disturbances and because of the distance between connected buildings and the balancing unit. As the network expands and more buildings become connected, two practical issues can be realised. The first issue is the possible cavitation in circulation pumps caused by the low-pressure levels at the furthest building away from the balancing unit. Another practical

issue is the risk of exceeding the maximum allowed pressure for system components as the system pressure increases when more buildings are connected. These issues require adopting either booster pumps to increase the network pressure or adding safety valves to relieve excess pressure from the network. Future research will aim at investigating these issues to provide designers with best practices.

---

# References

- Abugabbara, M., Javed, S., Bagge, H., & Johansson, D. (2020, October 1). Bibliographic analysis of the recent advancements in modeling and co-simulating the fifth-generation district heating and cooling systems. *Energy and Buildings*. Elsevier Ltd. <https://doi.org/10.1016/j.enbuild.2020.110260>
- ASHRAE Handbook Committee. (2017). Fundamentals of Control. In *ASHRAE Handbook - Fundamentals*.
- Berkeley Lab. (2021). The Modelica Buildings Library | Model Documentation. Retrieved May 4, 2021, from <https://simulationresearch.lbl.gov/modelica/releases/latest/help/Buildings.html>
- Brück, D., Elmqvist, H., Olsson, H., & Mattsson, S. E. (2002). Dymola for multi-engineering modelling and simulation. In *Proceedings of the 2nd International Modelica Conference, Oberpfaffenhofen, Germany, March 18-19, 2002* (pp. 55-1-55-58).
- Buffa, S., Cozzini, M., D'Antoni, M., Baratieri, M., & Fedrizzi, R. (2019). 5th generation district heating and cooling systems: A review of existing cases in Europe. *Renewable and Sustainable Energy Reviews*, 104(June 2018), 504–522. <https://doi.org/10.1016/j.rser.2018.12.059>
- Bünning, F., Wetter, M., Fuchs, M., & Müller, D. (2018). Bidirectional low temperature district energy systems with agent-based control: Performance comparison and operation optimization. *Applied Energy*, 209(October 2017), 502–515. <https://doi.org/10.1016/j.apenergy.2017.10.072>
- Çomakli, K., Yüksel, B., & Çomakli, Ö. (2004). Evaluation of energy and exergy losses in district heating network. *Applied Thermal Engineering*, 24(7), 1009–1017. <https://doi.org/10.1016/j.applthermaleng.2003.11.014>
- Connolly, D., Lund, H., Mathiesen, B. V., & Leahy, M. (2010). A review of computer tools for analysing the integration of renewable energy into various energy systems. *Applied Energy*, 87(4), 1059–1082. <https://doi.org/https://doi.org/10.1016/j.apenergy.2009.09.026>

- Cummings, M. L., & Britton, D. (2020). Regulating safety-critical autonomous systems: past, present, and future perspectives. In *Living with Robots* (pp. 119–140). Elsevier. <https://doi.org/10.1016/b978-0-12-815367-3.00006-2>
- Dahash, A., Mieck, S., Krautz, H., & Ochs, F. (2019). A comparative study of two simulation tools for the technical feasibility in terms of modeling district heating systems: An optimization case study. *Simulation Modelling Practice and Theory*, 91. <https://doi.org/10.1016/j.simpat.2018.11.008>
- EQUA. (2021). IDA Indoor Climate and Energy. Stockholm. Retrieved from <https://www.equa.se/en/ida-ice>
- Euroheat & Power. (2017). *Country by Country Survey*. Brussels.
- European Commission. (2011). Energy Efficiency Plan 2011: COM(2011) 109 final. Retrieved from <https://eur-lex.europa.eu/LexUriServ/LexUriServ.do?uri=COM:2011:0109:FIN:EN:PDF>
- European Commission. (2016). An EU Strategy on Heating and Cooling: COM(2016) 51 final.
- European Commission. (2020). Climate Action: 2050 long-term strategy. Retrieved from <https://unfccc.int/documents/210328>
- European Standard. (2018). *Communication systems for meters – Part 2: Wired M-Bus communication. EN 13757-2:2018*.
- Frederiksen, S., & Werner, S. (2013). *District heating and cooling*. Studentlitterature AB, Lund.
- Friedenthal, S., Griego, R., & Sampson, M. (2007). INCOSE Model Based Systems Engineering (MBSE) Initiative. Paper presented at INCOSE 2007 Symposium, San Diego, CA, USA, 2007. Retrieved from [https://www.researchgate.net/publication/267687693\\_INCOSE\\_Model\\_Based\\_Systems\\_Engineering\\_MBSE\\_Initiative](https://www.researchgate.net/publication/267687693_INCOSE_Model_Based_Systems_Engineering_MBSE_Initiative)
- Fritzson, P. (2004). *Principles of object-oriented modeling and simulation with Modelica 2.1*. IEEE.
- Government Offices of Sweden. (2016). Agreement on Swedish energy policy. Retrieved from <https://www.government.se/articles/2016/06/agreement-on-swedish-energy-policy/>
- Government Offices of Sweden. (2018). The Swedish climate policy framework. Retrieved February 17, 2021, from <https://www.government.se/information-material/2018/03/the-swedish-climate-policy-framework/>
- Government Offices of Sweden. (2021). Energy. Retrieved March 8, 2021, from

- <https://www.government.se/government-policy/energy/>
- Hafner, I., & Popper, N. (2017). On the terminology and structuring of co-simulation methods. In *Proceedings of the 8th International Workshop on Equation-Based Object-Oriented Modeling Languages and Tools Weßling, Germany – December 01 - 01, 2017* (Vol. 3, pp. 67–76). <https://doi.org/10.1145/3158191.3158203>
- Hansson, S. O. (2018). How to perform an ethical risk analysis (eRA). *Risk Analysis*, 38(9), 1820–1829. <https://doi.org/10.1111/risa.12978>
- Herkert, J., Borenstein, J., & Miller, K. (2020). The Boeing 737 MAX: Lessons for Engineering Ethics. *Science and Engineering Ethics*, 26(6), 2957–2974. <https://doi.org/10.1007/s11948-020-00252-y>
- Hess, S. (2016). Solar Thermal Process Heat (SPH) Generation. In *Renewable Heating and Cooling: Technologies and Applications* (pp. 41–66). Elsevier Inc. <https://doi.org/10.1016/B978-1-78242-213-6.00003-5>
- IEA. (2012). Energy technology perspectives 2012: Pathways to a clean energy system. International Energy Agency Paris.
- IEA. (2020). Heating. Retrieved March 18, 2021, from <https://www.iea.org/reports/heating>
- IEA. (2021a). Buildings: A source of enormous untapped efficiency potential. Retrieved from <https://www.iea.org/topics/buildings>
- IEA. (2021b). Global Energy Review: CO2 Emissions in 2020. Retrieved from <https://www.iea.org/articles/global-energy-review-co2-emissions-in-2020>
- International Energy Agency. (2020). World energy balances and statistics. Retrieved from <https://www.iea.org/subscribe-to-data-services/world-energy-balances-and-statistics>
- Kanso, A. M., Nelson, R. A., & Kitchen, P. J. (2020). BP and the Deepwater Horizon oil spill: A case study of how company management employed public relations to restore a damaged brand. *Journal of Marketing Communications*, 26(7), 703–731. <https://doi.org/10.1080/13527266.2018.1559218>
- Keebaş, A., Ali Alkan, M., & Bayhan, M. (2011). Thermo-economic analysis of pipe insulation for district heating piping systems. *Applied Thermal Engineering*, 31(17–18), 3929–3937. <https://doi.org/10.1016/j.applthermaleng.2011.07.042>
- Klein, S. A., Beckman, W. A., & Duffie, J. A. (1976). TRNSYS - A TRANSIENT SIMULATION PROGRAM. *ASHRAE Transactions*.
- Leveson, N. G., & Turner, C. S. (1993). An investigation of the Therac-25 accidents.

- Computer*, 26(7), 18–41. <https://doi.org/10.1109/MC.1993.274940>
- Long, N., Almajed, F., Rhein, J. Von, Henze, G., & Long, N. (2021). Development of a metamodeling framework for building energy models with application to fifth-generation district heating and cooling networks application to fifth-generation district heating and cooling networks. *Journal of Building Performance Simulation*, 14(2), 203–225. <https://doi.org/10.1080/19401493.2021.1884291>
- Lund, H., Østergaard, P. A., Chang, M., Werner, S., Svendsen, S., Sorknæs, P., ... Möller, B. (2018, December 1). The status of 4th generation district heating: Research and results. *Energy*. Elsevier Ltd. <https://doi.org/10.1016/j.energy.2018.08.206>
- Lund, H., Østergaard, P. A., Nielsen, T. B., Werner, S., Thorsen, J. E., Gudmundsson, O., ... Mathiesen, B. V. (2021). Perspectives on fourth and fifth generation district heating. *Energy*, 227, 120520. <https://doi.org/10.1016/j.energy.2021.120520>
- Lund, H., Werner, S., Wiltshire, R., Svendsen, S., Thorsen, J. E., Hvelplund, F., & Mathiesen, B. V. (2014, April 15). 4th Generation District Heating (4GDH). Integrating smart thermal grids into future sustainable energy systems. *Energy*. Elsevier Ltd. <https://doi.org/10.1016/j.energy.2014.02.089>
- Lygnerud, K. (2019). Business model changes in district heating: The impact of the technology shift from the third to the fourth generation. *Energies*, 12(9), 1–16. <https://doi.org/10.3390/en12091778>
- MathWorks Inc. (2021). Simulation and Model-Base Design. Retrieved from <https://se.mathworks.com/products/simulink.html>
- Mattsson, S. E., & Elmqvist, H. (1997). Modelica - An International Effort to Design the Next Generation Modeling Language. *IFAC Proceedings Volumes*, 30(4), 151–155. [https://doi.org/10.1016/s1474-6670\(17\)43628-7](https://doi.org/10.1016/s1474-6670(17)43628-7)
- Mazhar, A. R., Liu, S., & Shukla, A. (2018). A state of art review on the district heating systems. *Renewable and Sustainable Energy Reviews*, 96, 420–439. <https://doi.org/10.1016/j.rser.2018.08.005>
- Modelica Association. (2021). Modelica Association. Retrieved from <https://modelica.org/>
- Other tools - EnergyPlan. (2021). Retrieved from <https://www.energyplan.eu/othertools/>
- Pellegrini, M., & Bianchini, A. (2018). The innovative concept of cold district heating networks: A literature review. *Energies*, 11(1). <https://doi.org/10.3390/en11010236>

- QGIS. (2020). Version 3.16 Hannover. Retrieved from <https://qgis.org/en/site/forusers/download.html>
- Reinbold, V., Protopapadaki, C., Tavella, J. P., & Saelens, D. (2019). Assessing scalability of a low-voltage distribution grid co-simulation through functional mock-up interface. *Journal of Building Performance Simulation*, 0(0), 1–13. <https://doi.org/10.1080/19401493.2019.1597923>
- Rouleau, J., & Gosselin, L. (2021). Impacts of the COVID-19 lockdown on energy consumption in a Canadian social housing building. *Applied Energy*, 287, 116565. <https://doi.org/10.1016/j.apenergy.2021.116565>
- Schweiger, G., Heimrath, R., Falay, B., O'Donovan, K., Nageler, P., Pertschy, R., ... Leusbrock, I. (2018). District energy systems: Modelling paradigms and general-purpose tools. *Energy*, 164, 1326–1340. <https://doi.org/10.1016/j.energy.2018.08.193>
- Schweiger, G., Larsson, P.-O., Magnusson, F., Lauenburg, P., & Velut, S. (2017). District heating and cooling systems – Framework for Modelica-based simulation and dynamic optimization. *Energy*, 137, 566–578. <https://doi.org/https://doi.org/10.1016/j.energy.2017.05.115>
- Sepponen, M., & Heimonen, I. (2016). Business concepts for districts' Energy hub systems with maximised share of renewable energy. *Energy and Buildings*, 124, 273–280. <https://doi.org/10.1016/j.enbuild.2015.07.066>
- Sommer, T., Sulzer, M., Wetter, M., Sotnikov, A., Mennel, S., & Stettler, C. (2020). The reservoir network: A new network topology for district heating and cooling. *Energy*, 199, 117418. <https://doi.org/10.1016/J.ENERGY.2020.117418>
- Statistics Sweden. (2019). *Electricity supply, district heating and supply of natural gas 2019. Final statistics*. Retrieved from <https://www.scb.se/publication/40414>
- Steag-System Technologies. (2021). EBSILON®Professional. Retrieved from <https://www.steag-systemtechnologies.com/en/products/ebsilon-professional/>
- Steinkellner, S. (2011). *Aircraft vehicle systems modeling and simulation under uncertainty*. Licentiate dissertation, Linköping University. Retrieved from <http://urn.kb.se/resolve?urn=urn:nbn:se:liu:diva-68068>
- Talebi, B., Mirzaei, P. A., Bastani, A., & Haghighat, F. (2016). A Review of District Heating Systems: Modeling and Optimization. *Frontiers in Built Environment*, 2. <https://doi.org/10.3389/fbuil.2016.00022>
- The World Bank. (2021). GDP per capita growth (annul %). Retrieved from <https://data.worldbank.org/indicator/NY.GDP.PCAP.KD.ZG>

- Thomas, A., Menassa, C. C., & Kamat, V. R. (2017). Lightweight and adaptive building simulation (LABS) framework for integrated building energy and thermal comfort analysis. *Building Simulation*, 10(6), 1023–1044. <https://doi.org/10.1007/s12273-017-0409-5>
- Tiller, M. (2014). *Modelica by Example*. Retrieved from <https://mbe.modelica.university/>
- Tools - Functional Mock-up Interface. (2019). Retrieved from <https://fmi-standard.org/tools/>
- Tools - Modelica. (2021). Retrieved April 16, 2021, from <https://modelica.org/tools>
- UNFCCC. (2015). The Paris Agreement. Retrieved from <https://unfccc.int/process-and-meetings/the-paris-agreement/the-paris-agreement>
- United Nations. (2017). World population prospects: the 2017 revision, key findings and advance tables. *Department of Economics and Social Affairs PD, Editor. New York: United Nations*.
- Werner, S. (2017a). District heating and cooling in Sweden. *Energy*, 126, 419–429. <https://doi.org/10.1016/j.energy.2017.03.052>
- Werner, S. (2017b). International review of district heating and cooling. *Energy*, 137, 617–631. <https://doi.org/10.1016/j.energy.2017.04.045>
- Wetter, M., Bonvini, M., & Nouidui, T. S. (2016). Equation-based languages - A new paradigm for building energy modeling, simulation and optimization. *Energy and Buildings*, 117, 290–300. <https://doi.org/10.1016/j.enbuild.2015.10.017>
- Wetter, M., Treeck, C. Van, & Hensen, J. (2013). New generation computational tools for building and community energy systems. Retrieved from <http://www.iea-annex60.org/>
- Wetter, M., & Van Treeck, C. (2017). *New Generation Computational Tools for Building and Community Energy Systems Annex 60 Final Report*. <https://doi.org/10.4103/0973-1229.86137>
- Wetter, M., Zuo, W., Nouidui, T. S., & Pang, X. (2014). Modelica Buildings library. *Journal of Building Performance Simulation*, 7(4), 253–270. <https://doi.org/10.1080/19401493.2013.765506>
- Wirtz, M., Kivilip, L., Remmen, P., & Müller, D. (2020a). 5th Generation District Heating: A novel design approach based on mathematical optimization. *Applied Energy*, 260, 114158. <https://doi.org/https://doi.org/10.1016/j.apenergy.2019.114158>
- Wirtz, M., Kivilip, L., Remmen, P., & Müller, D. (2020b). Quantifying Demand Balancing in Bidirectional Low Temperature Networks. *Energy and Buildings*,



224, 110245. <https://doi.org/https://doi.org/10.1016/j.enbuild.2020.110245>

Zarin Pass, R., Wetter, M., & Piette, M. A. (2018). A thermodynamic analysis of a novel bidirectional district heating and cooling network. *Energy*, *144*, 20–30. <https://doi.org/10.1016/j.energy.2017.11.122>



Paper I







Contents lists available at ScienceDirect

## Energy &amp; Buildings

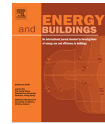
journal homepage: [www.elsevier.com/locate/enb](http://www.elsevier.com/locate/enb)

## Bibliographic analysis of the recent advancements in modeling and co-simulating the fifth-generation district heating and cooling systems

Marwan Abugabbara<sup>a,\*</sup>, Saqib Javed<sup>a</sup>, Hans Bagge<sup>b</sup>, Dennis Johansson<sup>a</sup><sup>a</sup>Department of Building and Environmental Technology, Division of Building Services, Lund University, Lund 221 00, Sweden<sup>b</sup>Department of Building and Environmental Technology, Division of Building Physics, Lund University, Lund 221 00, Sweden

## ARTICLE INFO

## Article history:

Received 17 February 2020

Revised 17 May 2020

Accepted 27 June 2020

Available online 11 July 2020

## Keywords:

District energy systems

Building energy

Decentralized substation

Heat pump

Equation-based modeling

Functional mock-up interface

## ABSTRACT

District heating and cooling systems have evolved through several development stages in order to improve their energy efficiency. The latest development reached the fifth generation where customers can be producers and/or consumers of thermal energy flows towards the network. The variety and complexity of system configurations and interactions between connected customers poses a challenge in adopting a suitable modeling paradigm capable of simulating each design case. Modelica language and the Functional Mock-up Interface standard are computational tools opted by the International Energy Agency for simulating building and community energy systems. This work aims to analyze the current status in literature where these tools are utilized in building and energy simulation with focus on district heating and cooling systems. Bibliographic maps and networks are presented to analyze the literature based on different bibliometrics. Among others, the analysis shows that coupled simulation between district and building energy models is a novel research area and can benefit in reducing the oversizing of space heating and cooling systems. In addition, the analysis demonstrates that the fifth generation district heating and cooling systems require advanced control strategies. These strategies need accurate and upfront specifications to decide a proper control strategy for each design case.

© 2020 The Authors. Published by Elsevier B.V. This is an open access article under the CC BY license (<http://creativecommons.org/licenses/by/4.0/>).

## Contents

1. Introduction	1
2. Method for literature analysis	3
3. Literature findings	3
3.1. Modelica in building energy simulation	4
3.2. Co-simulation between building performance simulation tools	5
4. Bibliographic analysis	6
5. Discussion	8
5.1. Control strategies and operation	8
5.2. Simulation performance and accuracy	9
6. Conclusions	9
Funding	9
Declaration of Competing Interest	9
Acknowledgments	9
References	10

## 1. Introduction

District Energy Systems (DES) offer the possibility to increase the exploitation of renewable energy and hence they are at the forefront of the engineering research [1–5]. The broad term of

\* Corresponding author at: Faculty of Engineering, Lund University, Box 118, 221 00 Lund, Sweden.

E-mail address: [marwan.abugabbara@hvac.lth.se](mailto:marwan.abugabbara@hvac.lth.se) (M. Abugabbara).

<https://doi.org/10.1016/j.enbuild.2020.110260>

0378-7788/© 2020 The Authors. Published by Elsevier B.V.

This is an open access article under the CC BY license (<http://creativecommons.org/licenses/by/4.0/>).

DES encompasses electrical, gas and thermal systems that are constructed in urban areas to distribute energy flows through power grids and pipe networks. District Heating and Cooling (DHC) systems are thermal application of DES and deemed most feasible in urban areas with high heat density [2]. The latest figures show that a growing number of the world's population is shifting from rural to urban areas. In 2018, the percentage of the world's population residing in urban areas reached 55%, a figure that is projected to increase up to 68% by 2050 [6]. As urbanization involves transformations in the built environment and infrastructure to meet the needs of shifting the spatial distribution of a population from rural to urban, DHC systems are expected to play a major role in this area. A survey carried out in 2017 by Euroheat & Power showed that there are about 6000 DHC networks currently in operation in Europe supplying about 12% of the total heat [7]. The previous figures suggest that DHC systems are therefore appropriate thermal energy applications that have potential enhancements that could attain greater benefits. One of these benefits, for example, could be the integration of multiple producers of thermal energy to the network [8].

DHC networks have evolved over time in order to achieve maximum energy efficiency and low distributions losses. Pellegrini and Bianchini [9] provided a background on the evolution of DHC generations. The first generation DHC systems were introduced in the United States in the late 19th century. The pipeline in these networks used steam as a heat carrier, which was later replaced by pressurized hot water with temperature over 100 °C to establish the second generation DHC networks. The authors also mentioned in their review that lowering the supply temperature in district heating networks to about 80 °C was needed since traditional residential buildings were heated using radiators that operate in this temperature range. This lowering in supply temperature led to the reengineering of the second generation DHC networks into the third generation that is currently widely applied [10]. Several technical and operating issues emerged in the third generation DHC networks. First, despite the high efficiency in energy production due to centralization, distribution losses in the network account for about 10–30% and pipeline insulation increased the cost [11,12]. Another issue is related to the sustainability of the technical components included in the systems. Components such as heat exchangers, valves, pumps and pipe material had to operate under high temperature conditions which affect their durability [13]. Furthermore, this generation limits the integration of low heat source renewables as high temperature sources are only suitable for integration [14]. The previous challenges have led to the inauguration of the fourth generation DHC networks which are usually characterized by supply temperatures in the range 50–70 °C. The main limitations in the fourth generation DHC system are: (i) separate pipes are needed to provide both heating and cooling and (ii) the production of energy is still centralized, which restricts the ability for network expansion due to design constraints. These are the main challenges that are addressed by today's fifth generation DHC systems.

The term "fifth generation" DHC systems has been firstly proposed in the H2020 project [15] and used in a number of studies, including [16,17]. Buffa et al. [18] provided an extensive review of existing applications of the fifth generation DHC systems in Europe. An example of such systems is seen at ETH Zurich Campus Hönggerberg [19]. The system at present supplies heating and cooling to four building clusters but is rapidly being expanded. The grid operates between 4 and 22 °C and is connected with three underground storages and four substations with distributed heat pumps. The maximum heating and cooling outputs of the system at present are 5.5 and 4.5 MW, respectively. A similar project in Lund, Sweden is currently in operation and being expanded [20]. The project consists of 14 buildings with a total heated floor area

of 110,000 m<sup>2</sup>. The energy demands in 2018 were 11 GWh heating and 5 GWh cooling. Currently six buildings are connected to the grid and the performance of the system is being evaluated. Generally, these systems can have different classifications depending on the method of heat rejection/extraction and the thermal energy flow from/towards the network. In its most simplified generic form, the fifth generation DHC system harnesses the shared energy concept which is realized in a network that connects "prosumers". The term "prosumer" refers to each customer connected to the network where they play the role of producer and/or consumer of thermal energy flows distributed through the network. A low-grade heat source is connected to a bidirectional pipe network that allows the simultaneous use of heating and cooling through a low temperature thermal network. Decentralized substations, typically heat pumps, are installed at the building level to boost and/or decrease the medium temperature to the desired levels each building requires.

Typically, modeling these systems involve components from various domains such as thermodynamics, fluid mechanics and controls. This results in a hybrid system of continuous time, discrete time and discrete events. Physical systems are described by differential algebraic equations consisting of derivatives with respect to time and space. On the other hand, digital control systems are described by discrete equations with time-, state- and step-events [21,22]. A problem that arises when attempting to model and simulate these heterogeneous systems is the requirement for a multi-domain platform that enables the evaluation of the dynamic behavior of the system in various design settings and configurations.

The International Energy Agency's Energy in Buildings and Communities Programme (IEA-EBC) Annex 60 called for an international project in 2012 to develop free open non-proprietary, new generation computational tools for building and community energy systems based on the Modelica, Functional Mock-up Interface (FMI) and Building Information Modeling standards [23]. Modelica is an equation-based object oriented modeling language that allows modeling physical systems involving multiple domains such as electrical, mechanical, thermodynamics and controls [24]. The FMI is a tool independent standard used for co-simulation of various dynamic models. By exploiting the outcomes of IEA-EBC Annex 60, the simulation of the fifth generation DHC systems can be realized. Moreover, the interoperability issues among different simulation tools can be alleviated.

Modelica language was developed through an international effort in 1996 benefiting from acausal modeling and advances in object-oriented constructs [25]. Models are described by differential, algebraic and discrete equations using a standardized interface that encapsulates the mathematical relations of a model between its interface variables and represent them graphically by an icon [26]. At the lowest level of abstraction, the mathematical equation describes the relationship between variables. At higher level of details, components are composed graphically through drag-and-drop and the externally visible variables called connectors are connected by a line between two connections. A connection defines another set of equations, one for each variable in the connector. By exploiting acausal modeling, the input/output relationship between system components is usually absent [27]. In such approach, a code generator is responsible for determining the input and output variables by employing symbolic algebra to determine an optimal solution sequence [28]. The use of Modelica has an extent use over variety of applications, we focus in this study on applications with respect to energy in buildings.

The complexity of modeling heterogeneous multi-domain systems yields a problem where no single simulation tool is capable of reproducing the behavior of the model [29]. One approach to surmount this problem is to model the system as subsystem mod-

els in different simulators which suit best for the specific domain [30]. However, to model and understand the dynamic behavior of the complete system, the need for integrated simulation becomes increasingly important [31–34]. Beausoleil-Morrison et al. [35] provided four options for integrated building performance simulation to extend the capabilities of existing tools: (i) add new features to existing tools; (ii) integrate the source code of one tool into another; (iii) develop a new building performance simulation tool and (iv) the use of co-simulation approach. Co-simulation offers a pragmatic solution to the problem of integrated simulation without demanding more resources.

The term co-simulation may cause confusion due to its several interpretations across different domains. Hafner and Popper [36] did an outstanding work in clarifying the semantics pertaining co-simulation and distinguished the different methods used in the context of co-simulation. They provided definitions for basic terms related to the field of modeling and simulation which we now introduce and suggest being used henceforth to avoid any ambiguity. A *model* refers to the mathematical representation of a system entities or process. A *simulation* is an experiment performed on a model. *Solver* refers to the solution algorithm which is applied to a specific simulation model. A *simulator* is a tool that allows the implementation and simulation of models. Co-simulation is an abbreviation for cooperative simulation or coupled system simulation [37,38] where two or more simulators are coupled to exchange data that depend on state variables in order to solve differential equations [39,40]. The coupled simulators differ in either solver algorithm or step size, hence, a master algorithm acts on the top level to organize the communication and data exchange between the coupled tools which are called slaves [22,36,41,42]. Master algorithms are not standardized, they can be developed both as a separate tool as well as an included feature of an existing simulation tool which plays the role of the master [43].

The aim of this study is to analyze the current status in literature where Modelica and co-simulation are utilized in modeling and simulation of DHC systems. The study is synthesized around five focal points. Section 2 explains the method used in the literature study. The literature findings including applications of Model-

ica and co-simulation in building energy simulation are introduced in Section 3. Bibliographic maps and networks are presented in Section 4 aiming to explore the literature based on different bibliometrics. Detailed discussion is covered in Section 5. Finally, conclusions are drawn in Section 6.

## 2. Method for literature analysis

A list of relevant publications had been compiled from six literature sources including journal articles and conference proceedings. The reader is asked to refer to the attached supplementary material to view the table of included publications. All publications included in this study were published before 1 October 2019. Fig. 1 shows the six literature sources together with the percentage of total number of publications each source accounts for. Out of a total number of 150 publications, proceedings of the International Modelica Conferences accounted for most of the literature in the list. The second largest set of publications were retrieved from a multistep query carried out in Scopus database. With nearly equal number of publications from the search in Scopus database, proceedings of the International Building Performance Simulation Association (IBPSA) Conferences comprised the third largest group of publications in the list. Other regional meetings such as the American and Japanese Modelica Conferences and the Equation-based Object-Oriented modeling Languages and Tools (EOOLT) workshops accounted together for 4% of the publications included in the list. The first International Modelica Conference took place in Lund, Sweden in October 2000. The conference then started to be organized about every other year in different locations. The International Modelica conference has reached its 13th event which took place in Regensburg, Germany in March 2019. Since its inauguration, the conference expanded its scope to cover wider themes and topics such as automotive, aerospace, electrical power, mechanics and transport, numerical methods and other subjects related to applications of Modelica. In this study, our primary focus was on proceedings related to the following topics: buildings, power and energy, thermodynamics and Functional Mock-up Interface.

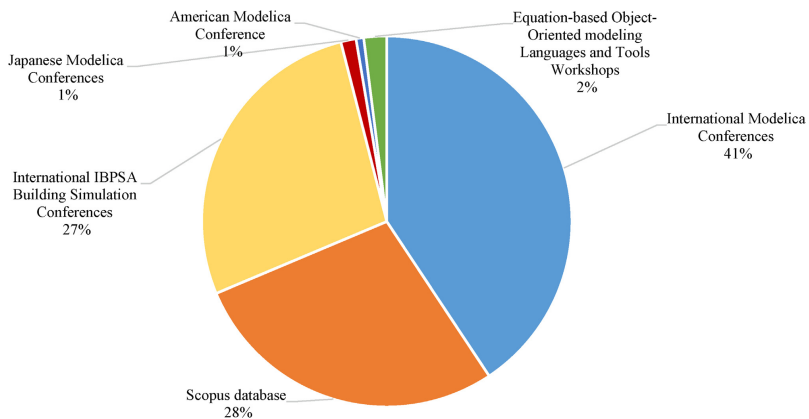

Fig. 1. Literature sources included in this study and their contribution to the list of publications.

**Table 1**  
Literature search strategy and its corresponding keyword categories.

Keyword category 1	modelica OR fmi OR fmu OR functional mock* OR co-simulation
Boolean operator	AND (title-abstract-keywords)
Keyword category 2	energy OR "building energy" OR dist* energy OR shar* energy OR grid OR network
Boolean operator	AND NOT (title-abstract-keywords)
Keyword category 3	chemi* OR vehicle OR solar OR mechat* OR maritime OR aircraft OR nuclear OR medical OR medicine OR "embedded system" OR hardware OR robot OR moecul* OR atom* OR motor OR optical OR "smart artifact" OR starch OR "speed train" OR infection OR processor OR military OR supermarkets
Boolean operator	AND NOT (source title)
Keyword category 4	nuclear OR ibpsa OR "Conference of the International Building Performance Simulation Association OR cardio"
Boolean operator	AND NOT (title)
Keyword category 5	workshop

The multistep query carried out in Scopus database is described in Table 1. The query is divided into five main keyword categories that aim to include and/or exclude specific topics when performing the request. The first two keyword categories attempt to combine studies where Modelica and co-simulation have been utilized in applications for district and building energy systems. A large set of articles that are not related to the scope of our study was ensued as a result of searching keywords in category 1 and 2. Therefore, the latter three categories in Table 1 aim to narrow down the search by limiting these unrelated topics. In each keyword category, the OR Boolean operator is used so that the search engine can find articles where at least one of the keywords listed in the category is contained. The asterisk symbol denotes the truncation search technique. In this technique, the asterisk symbol is added to the beginning or end of a word to retrieve word variations. For example, *dist\* energy* may find the words *district energy* and *distributed energy*. Moreover, the double quotation mark indicates the search for loose phrases where multiple words appear together in the designated search field. This technique is shown for example in keyword category 2 when searching for "building energy" to emphasize the importance for these two words to appear together.

Once all the literature have been collected, a bibliographic database file was created in order to generate bibliographic maps and networks by employing the software VOSviewer [44]. These maps and networks are presented in detail in Section 4. The database file followed the structure of a Comma-Separated Values (CSV) file exported from Scopus database. In total, 13 variables were considered and imported to VOSviewer for the all 150 publications. The variables in the database file are shown in Table 2 together with

their format and separator character in addition to an example that clarifies the definition of the 13 variables for an example article. It is worth mentioning that Scopus export function does not support accented characters. Hence, a look up process for accented characters, as explained in [45] was followed in order to remedy inadvertent inconsistencies between the original information and the exported ones. The number of citations for each publication was retrieved from Google Scholar. Missing publications in Google Scholar were assigned to a citation number equal to zero. Less than 9% of the total number of publications included in the list had a missing number of citations.

VOSviewer offers the possibility to explore bibliographic maps based on different types and units of analysis. We limited the generation of maps and networks to three types of analysis due to the following two reasons. Firstly, the reference string in the created bibliographic database file has harmonization problems. Different publications yielded different reference styles and therefore VOSviewer was prone to pitfalls in completely parsing a cited reference [46]. However, singular elements inside a cited reference such as authors, source title and year were able to be distinguished. Another reason to limit the types of analysis was related to the definition of different types of analysis and what they may refer to. For instance, the metric *bibliographic coupling* focuses on groups of items, e.g. authors, publications, etc., which cite the same publication. On the other hand, *co-citation analysis* measures the frequency of references coming in pairs [47]. We are primarily interested in identifying items with frequent occurrence within our literature list. These facts led us to focus more on specific types and units of analysis than others.

**3. Literature findings**

This section presents the findings derived from the included 150 publications. They are divided into two main areas related to Modelica language and co-simulation. The former focuses on the utilization of Modelica language in building performance and district energy simulation. The latter presents several co-simulation approaches and reviews applications between different simulation platforms.

**3.1. Modelica in building energy simulation**

Before delving into the review of previous applications of Modelica, we briefly discuss the open-source Modelica libraries that relied on the International Energy Agency Annex 60 and mentioned in [48]. RWTH Aachen [49] demonstrated the applicability of the *AixLib* library for building performance simulation on building and district scale. The library can also be used for both high and low order model of buildings with provided reference models for

**Table 2**  
Data structure of the bibliographic database file.

Variable	Format	Separator character	Example
Author	Text string	Comma	Hong T., Sun H., Chen Y., Taylor-Lange S.C., Yan D.
Title	Text string		An occupant behavior modeling tool for co-simulation
Year	YYYY		2016
Source title	Text string		Energy and Buildings
Volume	Integer		117
Issue	Integer		
Page start	Integer		272
Page end	Integer		281
Cited by	Integer		77
DOI	Character string		<a href="https://doi.org/10.1016/j.enbuild.2015.10.033">https://doi.org/10.1016/j.enbuild.2015.10.033</a>
Link	URL		<a href="https://www.sciencedirect.com/science/article/pii/S0378778815303480">https://www.sciencedirect.com/science/article/pii/S0378778815303480</a>
Affiliation	Text string	Semicolon	Lawrence Berkeley National Laboratory, United States; Tsinghua University, China
References	Text string	Semicolon	reference 1; reference 2; (...); reference 56



heating, ventilation, and air-conditioning components. The *BuildingSystems* library developed by UdK Berlin [50] can be used for single or multi-zone buildings or entire city districts. The *Buildings* library from Lawrence Berkeley National Laboratories [51] supports the design and operation of building energy and control systems. It also includes tools for pre- and post-processing, regression tests, co-simulation and real-time data exchange with building automation systems. KU Leuven developed the *IDEAS* library [52] for integrated district energy simulations. The library allows simultaneous transient simulation of thermal, control and electrical systems at both building and feeder levels. Source code of these libraries and implemented models can be edited and/or expanded to adapt changes for different use cases. These libraries had been extensively validated in modeling DHC systems and were reported in Annex 60 final report [53].

Since the primary focus of this study is to review the use of Modelica in simulating District Heating and Cooling systems (DHC), few of the Modelica applications with respect to this subject are herein introduced. Lubjankic et al. [54] developed the *FluidFlow* library to model complex thermal energy supply systems focusing on heating and ventilation systems, solar thermal, and DHC systems. The library has been validated empirically and against computational fluid dynamics simulations. EDF R&D in France developed *BuildSysPro* library [55] for modeling buildings and energy systems consisting of building envelope, building energy system, heating and ventilation systems, domestic hot water, solar panels, weather conditions and indoor comfort. Arce et al. [56] shared lessons learnt from modeling a low heat density District Heating (DH) system. They provided a detailed comparison of the different water models in the Modelica Standard Library (MSL) and motivated their decision to develop a new water model. The *DistrictHeating* library [57] was developed and used for accurate and robust simulation of DHC systems. The *Buildings* library and MSL had been used together to build a power-based model of a heating station for DH systems [58]. The dynamic behavior of DH networks using Modelica models was evaluated in [59] with a framework to parameterize these models with Geographic Information System data. Mans et al. [60] used Python and Modelica for automated generation and simplification of DHC networks by either reducing the total number of pipes in the model or by using static pipe models for short pipe sections. A Modelica library for low temperature thermal networks was developed [61] and the simulated system resulted in reduced energy losses between pipes and ground, an additional electrical load due to heat pumps was however observed. Different models of heat pumps has been presented in [62–67]. Approaches in developing the previous heat pump models involved for example a black box model connected to a module that calculates heat flow and compressor power by using lookup tables from manufacturer data. Another approach relied on a simplified mode of a vapor compression cycle with five refrigerant states. Many of the applications presented in the literature utilized co-simulation to benefit from the different capabilities of various tools through interoperable integrated simulation.

### 3.2. Co-simulation between building performance simulation tools

Many co-simulation frameworks have emerged over time. A comprehensive study and comparison among those is mentioned in [68]. We focus on two specific frameworks due to their wide application in the field of building performance simulation. The Building Controls Virtual Test Bed (BCVTB) [39] developed at Lawrence Berkeley National Laboratory is a middleware tool that allows connecting different simulation programs to exchange data during the time integration. It has features capable of and not limited to: (i) smaller computation time for data transfer compared to the

individual simulation programs when performing a co-simulation for a whole building; (ii) modularity and tool-independency that can couple for example Modelica, EnergyPlus [69], MATLAB [70] and online visualization tools of variables; (iii) communication over the internet and across different operating systems including Microsoft Windows, Linux and Mac OS X and (iv) running with a graphical user interface or as a console application without user integration. The presence of the additional layer, i.e., middleware, in the BCVTB in addition to the proficiency required in familiarizing the tool increase the complexity of the coupled system [68]. The Functional Mock-up Unit (FMU) import removed the concept of middleware and introduced a standardized interface between coupled programs.

In 2008 a consortium was initiated and organized under the Information Technology for European Advancement (ITEA2) project MODELISAR to develop a tool and vendor independent standard for the exchange of dynamic models and for co-simulation using a combination of eXtensible Markup Language (XML) files and compiled C-code [71,72]. The first version of the standard called Functional Mock-up Interface (FMI) was established by the automotive sector and released in 2010 and followed by version 2.0 in 2014 [73,74]. The use of the standard has expanded to other industries and engineering domains where now over 100 tools support FMI for model exchange or co-simulation [75]. The interactions between the tools abiding to the FMI standard happen in two ways [43]:

1. Model exchange: One simulation environment establishes the equations of one component and pass them over to another simulator which collects all component models and simulates all equations together.
2. Co-simulation: Each component's simulator solves its own equations whilst values which belong to more than one component are exchanged. Here the simulators have to be synchronized. Model exchange is the base for co-simulation as the same data for model exchange are needed.

A component that implements the FMI is called an FMU [22,72,76]. It consists of one zip-file containing the following files:

1. An XML-file contains the definition of all variables and model description of the FMU that is exposed to the environment in which the FMU shall be used.
2. A small set of easy to use C-functions are provided for all model equations for model exchange. For the FMI for co-Simulation, C-functions are also provided in source and/or binary form to initiate a communication with a simulation tool, to compute a communication time step and to perform the data exchange at the communication points.
3. Further data can be included in the FMU zip-file such as a model icon (bitmap file), documentation files, maps and tables needed by the model and/or shared libraries that are utilized.

To couple simulation tools, there exists two strategies to choose from [76,77]. First, in the *quasi-dynamic coupling* also called *loose coupling* or *ping-pong coupling* strategy, the distributed models run in sequence and simulators use data from preceding time steps where no iteration is required between the coupled simulators. The second strategy is a *fully-dynamic coupling* also called *strong coupling* or *onion coupling* in which the distributed models iterate within each time step to satisfy a predefined convergence criterion. The former strategy allows the use of multiple time steps in co-simulation whereas the latter can only use equal simulation time steps. Several previous studies have utilized co-simulation between different building performance simulation tools. This approach allows the use of the extensive features each single tool

is providing instead of using a monolithic simulation environment with limited capabilities.

An FMU-import was implemented in EnergyPlus and described in [78]. Two use cases were presented: modeling of a heating, ventilation and air-conditioning system and a shading controller in Modelica which were exported as FMU to EnergyPlus. A detailed building energy model was created using NANDRAD simulation tool [79] and exported as an FMU and integrated into a Modelica environment containing a heating and ventilation model. The study also investigated the co-simulation approach between the two tools using MASTERSIM [80] as a middleware for co-simulation and master algorithm. Since importing the FMU depends on functionalities specific to the simulator environment, a study by Chen et al. [81] aimed to provide a generic FMU interface for any Modelica simulator. Integrated modeling between TRNSYS [82] and Modelica was demonstrated in [27]. The Occupant Behavior Functional Mock-up Unit (obFMU) was developed and used to include stochastic functionality in modeling occupants while analyzing their impact on a building energy model in EnergyPlus [83]. Plessis G. et al. [84] managed to use the FMI to couple occupant behavior between SMACH, an agent-based platform developed by EDF R&D in France, and BuildSysPro library in Modelica for a building energy model. A specified use case of coupling a building's thermal envelope model in SIMULINK [85] with BRAHMS [86] model for multi-agent occupant behavior modeling was introduced in [73]. An approach that relied on using Java to model occupant behavior as a master simulation with a slave EnergyPlus building model was established in [32]. Several other attempts to couple building energy performance with computational fluid dynamics simulation tools are found in [42,87], while another study used the FMI to assess a ventilated double-skin fenestration system coupled with a compact fan-coil-unit [88]. Based on this literature review, integrated co-simulation of the fifth generation district heating and cooling systems including district and

building levels is necessary in order to recognize the various interactions between the decentralized substations and the pipes network.

4. Bibliographic analysis

Bibliographic maps and networks are created in order to provide the reader with a visual analysis of bibliometrics pertaining applications of Modelica and co-simulation for building energy simulation. By visually inspecting these maps, the reader can explore various metrics that link different items according to each type and unit of analysis. In this study, we limited our focus to three types of analysis due to the reasons previously mentioned at the end of Section 2. The three types of analysis are co-authorship, co-citation and co-occurrence. The maps and networks for the respective types of analysis are presented in Figs. 2, 3 and 4. To enhance visualization, character length in these figures was limited to 30 and network attraction and repulsion values were optimized. In addition, a cut-off for the largest connected items is only shown in these Figures. For example, map A in Fig. 2 shows the co-authorship network based on the authors unit of analysis. Out of 419 authors in the 150 publications list, 101 authors constitute to the largest set of connected authors and, hence, only those are shown in the map. Similarly, the authors correspond to 166 different organizations that are depicted in map B in Fig. 2. This map only presents the 65 largest connected organizations. Both map A and B in Fig. 2 have inherent information spread over two dimensions. The label size, i.e., circles, is proportional to the number of publications produced by the author or organization. The circle color indicates the time point where the literature was published. The circle color is interpreted according to the legend provided in the lower right corner of each map. A proliferation of publications can be seen over time, where years 2011 to 2015 marked significant events. Most of research institutions and organizations have

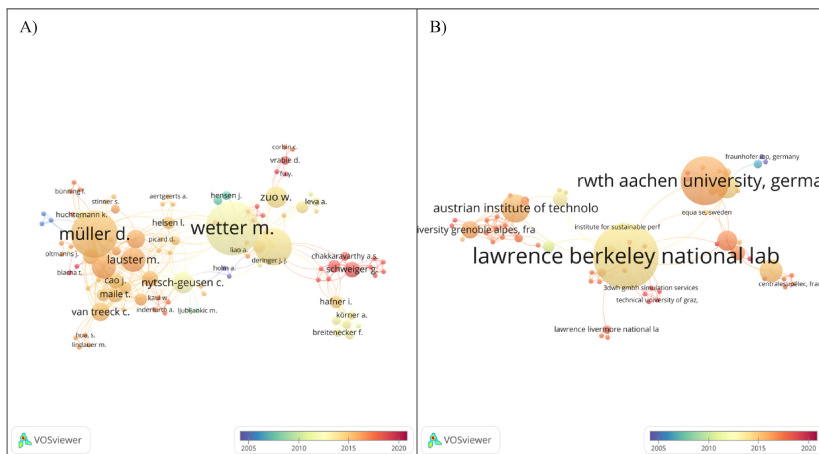

Fig. 2. Bibliographic maps and networks based on co-authorship type of analysis between authors (A) and organizations (B). For interpretation of colors and legends, the reader is referred to the web version of this article.

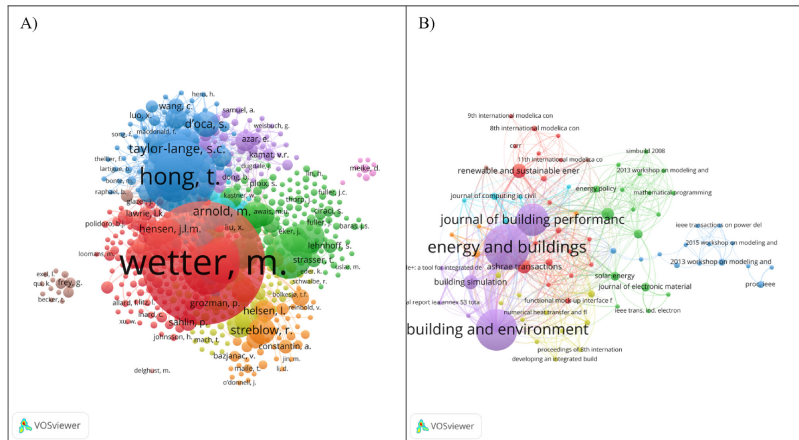

Fig. 3. Bibliographic maps and networks based on co-citation type of analysis between cited authors (A) and cited sources (B).

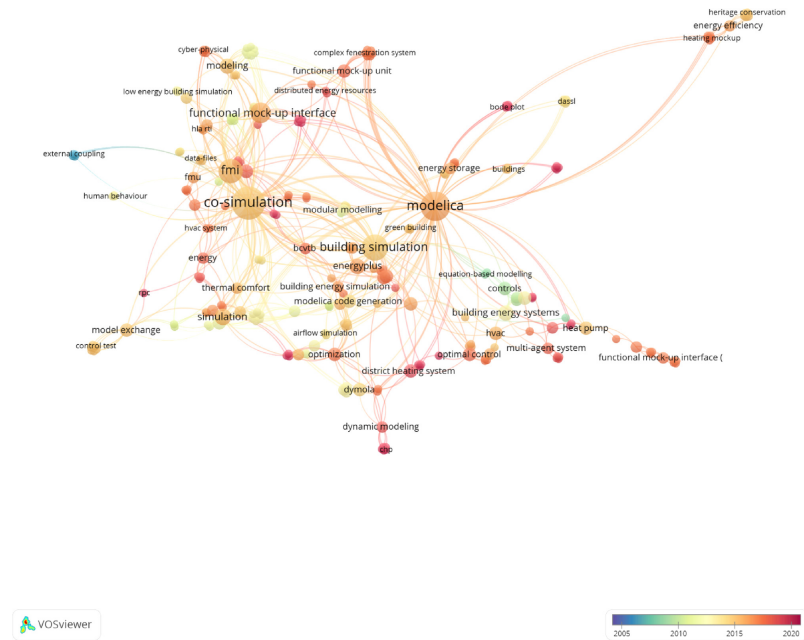

Fig. 4. Bibliographic map and network based on co-occurrence type of analysis and author keywords.

collaborated with Lawrence Berkeley National Laboratory in the United States where authors Wetter M. and Nouidui T. S. are affiliated. Müller D. from RWTH Aachen University in Germany has also contributed to a copious number of publications within the literature list. The red circles indicate that other organizations such as Technical University of Graz in Austria, Pacific Northwest National Laboratory in the United States and 3dwh GmbH Simulation Services in Germany had published more documents in the recent years.

Shifting the focus to Fig. 3 which presents maps and networks based on co-citation type of analysis for cited authors and cited sources. The colors in maps A and B indicate the number of clusters produced by the clustering technique explained in [89] with a resolution parameter set to 1. No conclusions should be elicited between the clusters in the two maps as each was produced separately. In contrast to the maps in Fig. 2, the circles here are weighted by the number of citations for authors and source titles. With a total number of 106 citations, map A shows that Wetter M. was the most cited author within the literature list followed by Hong T. with almost half the number. The cited references were communicated through wide range of sources. Journals; Energy and Building, Building Environment and Journal of Building Performance Simulation accounted for the most frequent sources, as shown in map B. In general, the cited references seemed to be communicated through journals and conferences related to building energy modeling and simulation.

The map and network illustrated in Fig. 4 link the author keywords included in the literature list. A link between two or more keywords is established when the keywords appear together in the same publication. The distance between multiple keywords implies how different applications belong or relate to the same research area. The total number of keywords found in the literature list is 401. The map, however, shows the largest set of connected items consisting of 251 keywords. At the first glance, one can recognize that the map is centered around four main keywords, these are *co-simulation*, *Modelica*, *Functional Mock-up Interface (FMI)* and *building simulation*. The size of the circles corresponding to the four keywords is relatively large and is weighted by the occurrence of each keyword. For instance, the lower right corner of the map shows studies that include applications of *district heating systems*, *dynamic modeling*, *control*, *heat pump* and *functional mock-up interface* that are connected to *Modelica* and *building simulation* main keywords. The keywords in this region have prominent red circles, which by interpreting against the legend color signify that the research addressing these topics is novel and recently published. The lower left corner of the map provides information about studies that utilized *co-simulation for building simulation*. It is clearly seen that tools such as the *Building Controls Virtual Test Bed (BCVTB)* and *EnergyPlus* are used for co-simulation between models related to *energy*, *thermal comfort*, *optimization*, *occupant behavioral modeling* and *Heating, Ventilation and Air-Conditioning (HVAC) systems*. The upper left corner links studies that combined both *Modelica* and the *FMI*. Here, complex systems such as *distributed energy resources*, *fenestration system* and *cyber-physical systems* distinctly employ the *FMI* to distribute the models across different platforms. Finally, the upper right corner shows studies that have solely used *Modelica* to cover research areas related to: development of the *Modelica Buildings* library, *energy storage* and *Differential/Algebraic System Solver* known as *DASSL*.

## 5. Discussion

The literature showed prolific applications of Modelica and co-simulation for integrated building energy performance simulation. In addition, the literature confirms that the simulation of district

energy systems using Modelica and co-simulation has grown rapidly in the recent few years. These applications substantiate that Modelica language, together with co-simulation, form a reliable paradigm for simulating complex and multi-domain systems such as the fifth generation District Heating and Cooling (DHC) systems. However, Buffa et al. [18] concluded in their review that a little has been done regarding the control strategies of the fifth generation DHC systems. Moreover, and as shown in studies [68,77,79,90,91], simulation performance becomes computationally taxing when coupling models with high level of details. Therefore, we summarize current research challenges related to the modeling and simulation of the fifth generation DHC systems to the following two categories: (i) optimal control strategies and operation and (ii) integrated simulation including building energy performance. The former challenge requires the specification of different system design settings and the impact of parameter estimation on control logics, while the latter involves investigating the simulation performance and speed when attempting to couple building models with DHC models. These are our main discussion points and are therefore in need for further elucidation.

### 5.1. Control strategies and operation

Basic control strategies in the fifth generation DHC systems differ from traditional ones. In traditional DHC systems, differential pressure control and supply temperature control are implemented in heat supply units, whereas in the fifth generation DHC systems these are absent [18]. The control logic depends on the system configuration in each design case. For instance, consider a closed-loop system where the heat carrier exchanges the thermal energy with a ground heat source. Here, the temperature is let to fluctuate freely. On the contrary, in open-loop systems the medium is discharged after exchanging thermal energy and therefore the supply temperature is dependent on the source. The differential pressure control, on the other hand, is found in design cases that involve a network with connected customers who are in need for heating while others are in need for cooling. In other cases, the direction and flow rate of the carrier medium are decided according to the interactions between the decentralized substations at each customer level. During the modeling and simulation of the fifth generation DHC systems in Modelica, parameter estimation is a key point that has a direct influence on the controllability and operation of the system. Parameters are one type of variables in Modelica models that are known before simulation starts and remain constant through the simulation. In the context of the fifth generation DHC systems, parameters may, for example, refer to the temperature difference between the two sides in the network or the fluid start temperature so that the simulation can be initialized. Depending on the simulated case, four possible outcomes may occur when one defines initial values for parameters [92]: (i) the solver may fail in trying to find consistent set of initial values if these are not fully specified; (ii) the solver produces errors due to an over specified system when a set of fixed inconsistent initial values are defined; (iii) the solver changes some of the initial values if they are guessed and (iv) the simulation may fail to converge when guessed inconsistent initial values are defined. Parameters affecting heat transfer between the soil and the pipes network should be given extra care. These include depth of burial, soil conductivity with respect to moisture and density, pipe insulation properties and distance between adjacent pipes [93]. Therefore, it is necessary to evaluate the impact of parameters estimation in order to choose fixed consistent initial values which would make the simulation more computationally efficient. Choosing a fixed consistent initial values has also the advantage of breaking algebraic loops [90] that are the artifact of multiple interdependent equations.

### 5.2. Simulation performance and accuracy

We begin discussing the simulation performance by revisiting the computational experiments reported in the International Energy Agency Annex 60 final report. A one-year simulation of a district energy grid connecting 6 dwellings required 1 day, 1 h and 49 min of CPU time. This reference simulation was performed completely using a single Modelica simulation environment. The best results were obtained by changing the solver tolerance and by using co-simulation together with parallel computing. This kind of simulation setup yielded a relative computation time of 0.37 when using two physical core CPU. The computation time can be further decreased with today's common multiple core processors. To improve the performance of simulating the fifth generation DHC systems, a few general remarks are here listed. First, although the entire building can be simulated in Modelica, it is recommended to avoid modeling buildings with high level of physical details [79] as buildings involve many components that result in thousands of differential equations. Second, the manual connection between building components involving equipment and control systems may be prone to errors as the level of details tends to increase. Moreover, Modelica language uses symbolic manipulation methods such as partitioning, tearing and inline integration [94–96] alongside conventional numerical solver methods in order to solve the unknowns in a system of equations. In building models with high level of detail, the code becomes large and the Modelica solver may be extremely slow in solving the unknowns. Another reason to avoid modeling buildings with high level of details is that buildings with heavy inertia can tolerate relatively large daily variations of heat supply from the district heating system while maintaining a good indoor climate [97]. In typical buildings, a 2 °C reduction in indoor temperature occurs after a few dozen hours of a 10% reduction in heat supply [57]. These figures indicate that building energy models have a time constant of hours where the resulting system model is not stiff. Non-stiff systems can be solved efficiently using explicit time integration algorithms [98]. However, when coupling building models with control systems which have dynamic response of seconds, the resulting stiff system requires implicit solvers to find a numerical solution. This point should be taken into consideration when choosing between loose or strong coupling strategies for co-simulation. In addition to the dynamic response of the system, shorter execution time is found in loosely coupled simulation, but for lower accuracy with increase of time step [77]. The accuracy decreases due to errors occurring in splitting the system and requirements for extrapolation during synchronization [36]. Integrated co-simulation of the fifth generation DHC systems would mitigate the current problem of oversizing heating and cooling systems at each building level. Space heating systems are designed based on the worst-case scenario, whilst during the full heating season the actual heating demand in the building varies between 0 and 80% of the design heat demand [99]. Co-simulation would also enable the analysis of how different types of buildings can contribute to the thermal energy flows in the network. This point can be achieved by simulating different occupant behaviors in order to derive the thermal demands for each building. Based on how much the building extract/reject heat from the network and how it affects the energy balance in the system, a decision can be made whether or not to connect the analyzed building to the network.

It follows from the discussion that it is highly required to prescribe the specifications with high level of details for each design case during the development process of a simulation model for the fifth generation DHC systems. Accurate specifications allow to analyze the dynamic behavior and numerical properties of the model from a model and global perspective. The former analyzes a specific configuration of the system, while the latter allows a

greater understanding of system performance under different configurations. Modelica language offers high flexibility in reusing and extending component models. This makes it a suitable modeling paradigm for modeling the various configurations in the fifth generation DHC systems. Component models such as heat pumps and bidirectional pipes need only to be developed once. A specific assembly of these pre-existing models arranges a specific configuration of the system. By modifying model parameters, a new configuration can be easily arranged using the same pre-existing models. This feature that Modelica offers saves modelers time when simulating different configurations and make component models less prone to errors. The process of sizing the system is accomplished by leveraging any of the co-simulation strategies. This enables the integration of buildings in the simulations during the initial design stage or when the network is being expanded.

### 6. Conclusions

This study aimed to analyze the status in the literature for simulating the fifth generation DHC systems. The technology behind these systems entails nontraditional installations and intricate interactions between connected buildings. The variety in system configuration and design cases required a modeling paradigm capable of predicting the dynamic behavior of the system for each simulated case. The simulation of the fifth generation DHC systems can be realized by utilizing Modelica and the Functional Mock-up Interface. The literature showed that these computational tools have a wide range of applications in building energy performance simulation. This work presented bibliographic maps and networks that link publications, authors, research organizations and research areas. The bibliographic analysis shows that employing Modelica and co-simulation for simulating district and building energy systems is novel but has some challenges that necessitate further research. Current research challenges in simulating the fifth generation DHC systems are the advanced control strategies and the integrated simulation including building energy performance. Decentralization of energy production and bidirectionality of energy flows make the control strategies differ in each design case. Co-simulation between district energy models and building models can help minimizing the oversizing of space heating and cooling systems. It also helps assessing the feasibility of connecting potential customers to the network by evaluating their contribution of thermal energy flows on the overall system efficiency. Coupling district and building energy models, however, conduces to a trade-off between simulation performance and model accuracy.

### Funding

This work was financially supported by the Swedish Energy Agency (Energimyndigheten) [grant number 45952–1]; E.ON Sverige AB; Danfoss Värmepumpar AB; Eneritech AB; Lambertsson Sverige AB; NIBE Industrier AB; Quantum Energi AB; and SKVP Info & Service AB. No potential conflict of interest was reported during the study.

### Declaration of Competing Interest

The authors declare that they have no known competing financial interests or personal relationships that could have appeared to influence the work reported in this paper.

### Acknowledgments

The authors gratefully acknowledge Jonas Lindhe for devoting the time to explain the principles of the fifth generation district

heating and cooling systems. The authors would also like to acknowledge Viktor Oman and Emma-Lisa Hansson for providing support in scientific information management and working with citation databases.

**Appendix A. Supplementary data**

Supplementary data to this article can be found online at <https://doi.org/10.1016/j.enbuild.2020.110260>.

**References**

[1] V. Reinbold, C. Protopapadakis, J.P. Tavella, D. Saelens, Assessing scalability of a low-voltage distribution grid co-simulation through functional mock-up interface, *J Build Perform Simul* (2019) 1–13, <https://doi.org/10.1080/19401493.2019.1597923>.

[2] S. Amiri, G. Weinberger, Increased cogeneration of renewable electricity through energy cooperation in a Swedish district heating system - A case study, *Renew Energy* (2018), <https://doi.org/10.1016/j.renene.2017.10.003>.

[3] D. Olshoorn, F. Haghighat, P.A. Mirzai, Integration of storage and renewable energy into district heating systems: A review of modelling and optimization, *Sol Energy* 136 (2016) 49–64, <https://doi.org/10.1016/j.solener.2016.06.054>.

[4] D. Wang, K. Orehoung, J. Carmeliet, Investigating the potential for district heating networks with locally integrated solar thermal energy supply, *Energy Procedia* 122 (2017) 1057–1062, <https://doi.org/10.1016/j.egyspro.2017.07.432>.

[5] M. Sepponen, I. Heimonen, Business concepts for districts' Energy hub systems with maximised share of renewable energy, *Energy Build* 124 (2016) 273–280, <https://doi.org/10.1016/j.enbuild.2015.07.066>.

[6] United Nations, World Urbanization Prospects 2018: Highlights, 2018.

[7] Euroheat & Power, Country by Country Survey, Brussels: 2017.

[8] B. Rezaie, M.A. Rosen, District heating and cooling: Review of technology and potential enhancements, *Appl Energy* 93 (2012) 2–10, <https://doi.org/10.1016/j.apenergy.2011.04.020>.

[9] Pellegrini M, Bianchini A. The innovative concept of cold district heating networks: A literature review, *Energy* 2018;11. <https://doi.org/10.3390/en11010236>.

[10] S. Werner, International review of district heating and cooling, *Energy* (2017), <https://doi.org/10.1016/j.energy.2017.04.045>.

[11] K. Çomaklı, B. Yüksel, Ö. Çomaklı, Evaluation of energy and exergy losses in district heating network, *Appl Therm Eng* 24 (2004) 1009–1017, <https://doi.org/10.1016/j.applthermaleng.2003.11.014>.

[12] A. Keebas, M. Ali Alkan, M. Bayhan, Thermo-economic analysis of pipe insulation for district heating piping systems, *Appl Therm Eng* 31 (2011) 3929–3937, <https://doi.org/10.1016/j.applthermaleng.2011.07.042>.

[13] T. Tereshchenko, N. Nord, Importance of Increased Knowledge on Reliability of District Heating Pipes, *Procedia Eng* 146 (2016) 415–423, <https://doi.org/10.1016/j.proeng.2016.06.423>.

[14] C. Winterscheid, S. Holler, J.O. Dalenbäck, Integration of solar thermal systems into existing district heating systems, *Energy Procedia* 116 (2017) 158–169, <https://doi.org/10.1016/j.egyspro.2017.05.064>.

[15] EU H2020 FLEXNETS project n.d. <http://www.flexynets.eu/en/>.

[16] I.P. Pattijn, A. Baumanns, Fifth-generation thermal grids and heat pumps: A pilot project in Leuven, Belgium, *HPT Mag* 35 (2017) 53–57.

[17] F. Büning, M. Wetter, M. Fuchs, D. Müller, Bidirectional low temperature district energy systems with agent-based control: Performance comparison and operation optimization, *Appl Energy* 209 (2018) 502–515, <https://doi.org/10.1016/j.apenergy.2017.10.072>.

[18] S. Buffa, M. Cozzini, M. D'Antoni, M. Barateri, R. Fedrizzi, 5th generation district heating and cooling systems: A review of existing cases in Europe, *Renew Sustain Energy Rev* 104 (2019) 504–522, <https://doi.org/10.1016/j.rser.2018.12.059>.

[19] Energy\_grid\_ETH Zurich n.d. <https://ethz.ch/en/eth-zurich/sustainability/campus/environment/energy/energy-grid.html> (accessed May 15, 2020).

[20] E.ON ectogrid - Shared energy for a sustainable city n.d. <http://ectogrid.com/> (accessed May 15, 2020).

[21] W.S. An, Enhanced Discretisation Method for Storage Tank Models within Energy Systems, Proc. 5th Int. Model. Conf. Vienna, Austria, Sept. 4–5 (2006) (2006) 243–249.

[22] Blochwitz T, Otter M, Arnold M, Bausch C, Claus C, Elmqvist H, et al. The Functional Mockup Interface for Tool independent Exchange of Simulation Models, Proc. 8th Int. Model. Conf. Dresden, Ger. March 20–22, 2011, 2011, p. 105–14.

[23] Wetter M, Treeck C Van, Hensen J. New generation computational tools for building and community energy systems. IEA EBC Annex 60 2013. <http://www.iea-annex60.org/>.

[24] P. Fritzon, V. Engelson, Modelica - A unified object-oriented language for system modeling and simulation, *Lect Notes Comput Sci (Including Subser Lect Notes Artif Intelligence Lect Notes Bioinformatics)* 1445 (1998) 67–90, <https://doi.org/10.1007/BFb0054087>.

[25] S.E. Mattsson, H. Elmqvist, Modelica - An International Effort to Design the Next Generation Modeling Language, *IFAC Proc* 30 (1997) 151–155, [https://doi.org/10.1016/S1474-6670\(17\)43628-7](https://doi.org/10.1016/S1474-6670(17)43628-7).

[26] M. Wetter, Modelica-based modelling and simulation to support research and development in building energy and control systems, *J Build Perform Simul* 2 (2009) 143–161, <https://doi.org/10.1080/19401490902818259>.

[27] Elsheikh A, Widl E, Pensky P, Dubisch F, Brychta M, Bassiotti D, et al. Modelica-Enabled Rapid Prototyping Via Trnsys, Proc. BS2013 13th Conf. Int. Build. Perform. Simul. Assoc. Chambéry, Fr. August 26–28, 2013, p. 3291–8.

[28] Wetter, Michael; Zuo, Wangda; Nouidui TS. MODELING OF HEAT TRANSFER IN ROOMS IN THE MODELICA " BUILDINGS " LIBRARY, Proc. Build. Simul. 2011 12th Conf. Int. Build. Perform. Simul. Assoc. Sydney, 14–16 Novemb., 2011, p. 1096–103.

[29] Schweiger G, Gomes C, Engel G, Hafner I, Schoegg J-P, Posch A, et al. Functional Mock-up Interface: An empirical survey identifies research challenges and current barriers, Proc. Am. Model. Conf. 2018, Oct. 9–10, Somb. Conf. Center, Cambridge MA, USA, 2018, p. 138–46, <https://doi.org/10.3384/ecp18154138>.

[30] Bastian J, Clauß C, Wolf S, Schneider P. Master for Co-Simulation Using FMI, Proc. 8th Int. Model. Conf. Dresden, Ger. March 20–22, 2011, 2011, p. 115–20, <https://doi.org/10.3384/ecp11063115>.

[31] M.U. Awais, P. Palensky, W. Mueller, E. Widl, A. Elsheikh, Distributed hybrid simulation using the HLA and the Functional Mock-up Interface, *IECON Proc. (Industrial Electron. Conf., IEEE (2013) 7564–7569*, <https://doi.org/10.1109/IECON.2013.6760393>.

[32] Li, R. Wei F, Zhao Y, Zeller W. Implementing Occupant Behaviour in the Simulation of Building Energy Performance and Energy Flexibility: Development of Co-Simulation Framework and Case Study, Proc. 15th IBPSA Conf. San Fr. CA, USA, Aug. 7–9, 2017, 2017, p. 802–9.

[33] Schumacher M, Fuchs M, Dirik M, Urban Energy System Simulation using the Functional Mock-up Interface, Proc. 15th IBPSA Conf. San Fr. CA, USA, Aug. 7–9, 2017, 2017, p. 2484–93, <https://doi.org/https://doi.org/10.26868/25222708.2017.704>.

[34] O. Johansson, A. Pop, P. Fritzon, Engineering Design Tool Standards and Interfacing Possibilities to Modelica Simulation Tools, Proc. 5th Int. Model. Conf. Vienna, Austria, Sept. 4–5 (2006) 259–368.

[35] Beausoleil-Morrison L, Macdonald F, Kummert M, Just R, McDowell T. Co-simulation between ESP-r and TRNSYS: more highly resolved modelling of integrated building and energy systems, Proc. Build. Simul. 2013/13th Conf. Int. Build. Perform. Simul. Assoc. Chambéry, FRA, August 26–28, 2013, p. 3458–65.

[36] Hafner I, Popper N. On the terminology and structuring of co-simulation methods, Proc. 8th Int. Work. Equation-Based Object-Oriented Model. Lang. Tools Weßling, Ger. — December 01 - 01, 2017, vol. 3, 2017, p. 67–76, <https://doi.org/10.1145/3158191.3158203>.

[37] M. Busch, Zur effizienten Kopplung von Simulationsprogrammen. kassel, University Press GmbH, 2012.

[38] K.C. Park, C.A. Felippa, Partitioned Analysis of Coupled Systems, *Comput Methods Transient Anal* 190 (1983) 157–215.

[39] M. Wetter, Co-simulation of building energy and control systems with the building controls virtual test bed, *J Build Perform Simul* 4 (2011) 185–203, <https://doi.org/10.1080/19401493.2010.518631>.

[40] P. Nageler, G. Schweiger, H. Schranzhofer, T. Mach, R. Heimrath, C. Hochenauer, Novel method to simulate large-scale thermal city models, *Energy* 157 (2018) 632–646, <https://doi.org/10.1016/j.energy.2018.05.190>.

[41] Claus C, Majetta K, Meyer R. Application of Richardson Extrapolation to the Co-Simulation of FMUs from Building Simulation, Proc. 12th Int. Model. Conf. Prague, Czech Republic, May 15–17, 2017, 2017, p. 79–88, <https://doi.org/10.3384/ecp1713279>.

[42] W.S. Dols, S.J. Emmerich, B.J. Polidoro, Coupling the multizone airflow and contaminant transport software CONTAM with EnergyPlus using co-simulation, *Build Simul* 9 (2016) 469–479, <https://doi.org/10.1007/s12273-016-0279-2>.

[43] Enge-Rosenblatt O, Clauß C, Schneider A, Schneider P. Functional Digital Mock-up and the Functional Mock-up Interface - Two Complementary Approaches for a Comprehensive Investigation of Heterogeneous Systems, Proc. 8th Int. Model. Conf. Dresden, Ger. March 20–22, 2011, 2011, p. 748–55, <https://doi.org/10.3384/ecp11063748>.

[44] N.J. van Eck, L. Waltman, VOSviewer version 1.6.13 (2019).

[45] Elsevier. Scopus: Access and use Support Center n.d. [https://service.elsevier.com/app/answers/detail/a\\_id/14775/supporthub/scopus/kw/accepted+characters/](https://service.elsevier.com/app/answers/detail/a_id/14775/supporthub/scopus/kw/accepted+characters/) (accessed November 6, 2019).

[46] van Eck NJ, Waltman L. VOSviewer Manual - Manual for VOSviewer version 1.6.13 2019. [https://www.vosviewer.com/documentation/Manual\\_VOSviewer\\_1.6.13.pdf](https://www.vosviewer.com/documentation/Manual_VOSviewer_1.6.13.pdf) (accessed November 6, 2019).

[47] L. Eghebe, R. Rousseau, Co-citation, bibliographic coupling and a characterization of lattice citation networks, *Scientometrics* 55 (2002) 349–361, <https://doi.org/10.1023/A:1024558612014>.

[48] Thorade M, Radler J, Remmen P, Matie T, Wimmer R, Cao J, et al. An Open Toolchain for Generating Modelica Code from Building Information Models, Proc. 11th Int. Model. Conf. Versailles, Fr. Sept. 21–23, 2015, vol. 118, 2015, p. 383–91, <https://doi.org/10.3384/ecp15118383>.

[49] Fuchs M, Constantin A, Lauster M. STRUCTURING THE BUILDING PERFORMANCE MODELICA LIBRARY AXILIB FOR OPEN COLLABORATIVE DEVELOPMENT, Proc. BS2015 14th Conf. Int. Build. Perform. Simul. Assoc. Hyderabad, India, Dec. 7–9, 2015, 2015, p. 331–8.

- [50] C. Nytsch-Geusen, J. Huber, M. Ljubičankić, J. Rädler, Modelica BuildingSystems - eine Modellbibliothek zur Simulation komplexer energietechnischer Gebäudesysteme, *Bauphysik* 35 (2013) 21–29, <https://doi.org/10.1002/bapi.201310045>.
- [51] M. Wetter, W. Zuo, T.S. Noudiui, X. Pang, Modelica Buildings library, *J. Build Perform. Simul.* 7 (2014) 253–270, <https://doi.org/10.1080/19401493.2013.765506>.
- [52] Baetens R, De Coninck R, Jorissen F, Picard D, Helsen L, Saelens D. Openideas - An open framework for integrated district energy simulations. 14th Int Conf IBPSA - Build Simul 2015, BS 2015, Conf Proc 2015:347-54.
- [53] Wetter M, Van Treeck C. New Generation Computational Tools for Building and Community Energy Systems Annex 60 Final Report. 2017. <https://doi.org/10.4103/0973-1229.86157>.
- [54] M. Ljubičankić, C. Nytsch-Geusen, S. Unger, Modelling of complex thermal energy supply systems based on the Modelica-Library FluidFlow, *Proc. 7th Int. Model. Conf. Como, Italy, Sep. 20–22 (2009) (2009)* 335–340.
- [55] Plessis G, Kämmmerlin A, Lindsay A, BuildSysPro: a Modelica library for modelling buildings and energy systems. *Proc. 10th Int. Model. Conf. March 10–12, 2014, Lund, Sweden, vol. 96, 2014, p. 1161–9.* <https://doi.org/10.3384/ecp140961161>.
- [56] del Hoyo Arce I, López Perez S, Herrero López S, Mesonero Dávila I. Lessons Learnt from Network Modelling of a Low Heat Density District Heating System. *Proc. 11th Int. Model. Conf. Versailles, Fr. Sept. 21–23, 2015, 2015, p. 393–400.* <https://doi.org/10.3384/ecp15118393>.
- [57] Giraud L, Baviere R, Vallée M, Paulus C. Presentation, Validation and Application of the DistrictHeating Modelica Library. *Proc. 11th Int. Model. Conf. Versailles, Fr. Sept. 21–23, 2015, 2015, p. 79–88.* <https://doi.org/10.3384/ecp1511879>.
- [58] Dahash A, Steingrube A, Elci M. A Power-Based Model of a Heating Station for District Heating (DH) System Applications. *Proc. 12th Int. Model. Conf. Prague, Czech Republic, May 15–17, 2017, vol. 132, 2017, p. 415–24.* <https://doi.org/10.3384/ecp17132415>.
- [59] Schwan T, Ziesler O, Eckhardt T, Unger R. A Modelica-Based Framework for District Heating Grid Simulation. *Proc. 13th Int. Model. Conf. Regensburg, Ger. March 4–6, 2019, vol. 157, 2019, p. 159–68.* <https://doi.org/10.3384/ecp19157159>.
- [60] Mans M, Blacha T, Remmen P, Müller D. Automated model generation and simplification for district heating and cooling networks. *Proc. 13th Int. Model. Conf. Regensburg, Ger. March 4–6, 2019, vol. 157, 2019, p. 179–86.* <https://doi.org/10.3384/ecp19157179>.
- [61] Rogers R, Lakhian V, Lighthstone M, Cotton JS. Modeling of Low Temperature Thermal Networks Using Historical Building Data from District Energy Systems. *Proc. 13th Int. Model. Conf. Regensburg, Ger. March 4–6, 2019, vol. 157, 2019, p. 543–50.* <https://doi.org/10.3384/ecp19157543>.
- [62] Matthes P. Coupled, Simulation of Building Structure and Building Services Installations with Modelica. *Proc. 5th Int. Model. Conf. Vienna, Austria, Sept. 4–5 (2006) (2006)* 717–723.
- [63] K. Huchtemann, D. Müller, Advanced simulation methods for heat pump systems, *Proc. 7th Int. Model. Conf. Como, Italy, Sep. 20–22 (2009) (2009)* 798–803.
- [64] T. Valhenkamp, S. Wischhusen, FluidDissipation for Applications - A Library for Modelling of Heat Transfer and Pressure Loss in Energy Systems, *Proc. 7th Int. Model. Conf. Como, Italy, Sep. 20–22 (2009) (2009)* 132–141.
- [65] Cimmino M, Wetter M. Modelling of Heat Pumps with Calibrated Parameters Based on Manufacturer Data. *Proc. 12th Int. Model. Conf. Prague, Czech Republic, May 15–17, 2017, vol. 132, 2017, p. 219–26.* <https://doi.org/10.3384/ecp17132219>.
- [66] Laughman CR, Bortoff SA, Qiao H. Modeling and Coordinated Control of an Air-Source Heat Pump and Hydronic Radiant Heating System. *Proc. 2nd Japanese Model. Conf. Tokyo, Japan, May 17–18, 2018, vol. 148, 2019, p. 77–85.* <https://doi.org/10.3384/ecp1814877>.
- [67] Mehrfeld P, Huchtemann K, Müller D. Influences of Hot Water Tank States and the Order of Test Days to Gain the Annual Efficiency of Heat Pump Systems Evaluated Using Modelica. *Proc. 15th IBPSA Conf. San Fr. CA, USA, Aug. 7–9, 2017, 2017, p. 1499–504.*
- [68] A. Thomas, C.C. Menassa, V.R. Kamat, Lightweight and adaptive building simulation (LABS) framework for integrated building energy and thermal comfort analysis, *Build Simul* 10 (2017) 1023–1044, <https://doi.org/10.1007/s12273-017-0409-5>.
- [69] D.B. Crawley, L.K. Lawrie, F.C. Winkelmann, W.F. Buhl, Y.J. Huang, C.O. Pedersen, et al., *EnergyPlus: Creating a new-generation building energy simulation program*, *Energy Build* 33 (2001) 319–331, [https://doi.org/10.1016/S0378-7788\(00\)00114-6](https://doi.org/10.1016/S0378-7788(00)00114-6).
- [70] MathWorks. MATLAB - MathWorks - MATLAB & Simulink n.d. <https://se.mathworks.com/products/matlab.html> (accessed November 11, 2019).
- [71] Schwan T, Unger R, Pipiorke I. Aspects of FMU in Building Simulation. *Proc. 12th Int. Model. Conf. Prague, Czech Republic, May 15–17, 2017, vol. 73–8.* <https://doi.org/10.3384/ecp1713273>.
- [72] Noudiui TS, Wetter M. Tool coupling for the design and operation of building energy and control systems based on the Functional Mock-up Interface standard. *Proc. 10th Int. Model. Conf. March 10–12, 2014, Lund, Sweden, vol. 96, 2014, p. 311–20.* <https://doi.org/10.3384/ecp14096311>.
- [73] Gaaloul S, Dang H, Kashti A, Delinchant B, Wurtz F. A NEW CO-SIMULATION ARCHITECTURE FOR MIXING DYNAMIC BUILDING SIMULATION AND AGENT ORIENTED APPROACH FOR USERS BEHAVIOUR MODELLING. *Proc. BS2013 13th Conf. Int. Build. Perform. Simul. Assoc. Chambéry, Fr. August 26–28, 2013, p. 3225–33.*
- [74] Functional Mock-up Interface n.d. <https://fmi-standard.org/> (accessed November 11, 2019).
- [75] Tools | Functionl Mock-up Interface n.d. <https://fmi-standard.org/tools/> (accessed November 11, 2019).
- [76] K. Wang, P.O. Siebers, D. Robinson, Towards Generalized Co-simulation of Urban Energy Systems, *Procedia Eng* 198 (2017) 366–374, <https://doi.org/10.1016/j.proeng.2017.07.092>.
- [77] Trcka M, Wetter M, Hensen J. COMPARISON OF CO-SIMULATION APPROACHES FOR BUILDING AND HVAC / R SYSTEM SIMULATION Technische Universität Eindhoven , Eindhoven , The Netherlands , Simulation Research Group , Building Technologies Department , Environmental Energy Technologies Division. *Proc. 10th Int. IBPSA Conf. Beijing, China, Sept. 3–6, 2007, 2007, p. 1418–25*
- [78] Noudiui TS, Wetter M, Zuo W, Berkeley L. FUNCTIONAL MOCK-UP UNIT IMPORT IN ENERGYPLUS FOR CO-SIMULATION. *Proc. BS2013 13th Conf. Int. Build. Perform. Simul. Assoc. Chambéry, Fr. August 26–28, 2013, p. 3275–82.* <https://doi.org/10.3384/ecp1327582>.
- [79] Nicolai A, Paepcke A. Co-Simulation between detailed building energy performance simulation and Modelica HVAC component models. *Proc. 12th Int. Model. Conf. Prague, Czech Republic, May 15–17, 2017, 2017, p. 63–72.* <https://doi.org/10.3384/ecp1713263>.
- [80] MASTERSIM n.d. <http://bauklimatik-dresden.de/mastersim/> (accessed November 11, 2019).
- [81] W. Chen, M. Huhn, P. Fritzon, W. Chen, M. Huhn and P.F. A Generic FMU Interface for Modelica. *Proc. 4th Int. Work. Equation-Based Object-Oriented Model. Lang. Tools. Zurich, Switzerland; Sept. 5 (2011) (2011)* 19–24.
- [82] S.A. Klein, W.A. Beckman, J.A. Duffie, TRNSYS - A TRANSIENT SIMULATION PROGRAM, *ASHRAE Trans* (1976).
- [83] Y. Chen, X. Liang, T. Hong, X. Luo. Simulation and visualization of energy-related occupant behavior in office buildings, *Build Simul* 10 (2017) 785–798, <https://doi.org/10.1007/s12273-017-0355-2>.
- [84] Plessis G, Amouroux E, Haradji Y. Coupling occupant behaviour with a building energy model - A FMU application. *Proc. 10th Int. Model. Conf. March 10–12, 2014, Lund, Sweden, vol. 96, 2014, p. 321–6.* <https://doi.org/10.3384/ecp14096321>.
- [85] MathWorks. SIMULINK - Simulation and Model Based Design - MATLAB & Simulink n.d. <https://se.mathworks.com/products/simulink.html> (accessed November 11, 2019).
- [86] M. Sierhuis, W.J. Clancy, R.J.J. van Hoof, Brahm: A multi-agent modelling environment for simulating work processes and practices. *Int J Simul Process Model.* 3 (2007) 134–152, <https://doi.org/10.1504/IJSPM.2007.015238>.
- [87] W. Mazurkiewicz, N. Mendes, R.C.L. Oliveira, Co-Simulation to Bring Advanced Physics to Building Thermal Performance Analysis. *Proc. 15th IBPSA Conf. San Fr 7–9 (2017) 2503–2511.*
- [88] B. Bueno, M. Street, T. Pfug, C. Braesch, A co-simulation modelling approach for the assessment of a ventilated double-skin complex fenestration system coupled with a compact fan-coil unit, *Energy Build* 151 (2017) 18–27, <https://doi.org/10.1016/j.enbuild.2017.04.029>.
- [89] L. Waltman, N.J. van Eck, E.C.M. Noyons, A unified approach to mapping and clustering of bibliometric networks, *J Informetr* 4 (2010) 629–635, <https://doi.org/10.1016/j.joi.2010.07.002>.
- [90] Jorissen F, Wetter M, Helsen L. Simulation Speed Analysis and Improvements of Modelica Models for Building Energy Simulation. *Proc. 11th Int. Model. Conf. Versailles, Fr. Sept. 21–23, 2015, 2015, p. 59–69.* <https://doi.org/10.3384/ecp1511859>.
- [91] J. Chapman, P.O. Siebers, D. Robinson, On the multi-agent stochastic simulation of occupants in buildings, *J Build Perform Simul* 11 (2018) 604–621, <https://doi.org/10.1080/19401493.2017.1417483>.
- [92] Fredriksson E, Führer C. Modelica & Dymola Introduction. *Lect. notes, Lund Univ.*, n.d.
- [93] J. Yi, Methods of Heat Transfer Analysis of Buried Pipes in District Heating and Cooling Systems 2. Method and Influence Factors of Heat Transmission and Distribution Pipeline, *Appl Eng* 2 (2018) 33–38.
- [94] P. Bunus, P. Fritzon, Automated Static Analysis of Equation-Based Components, *Simulation* 80 (2004) 321–345, <https://doi.org/10.1177/0037549704046340>.
- [95] F.E. Cellier, E. Kofman, *Continuous System Simulation*, Springer, 2006, <https://doi.org/10.1007/0-387-30260-3>.
- [96] H. Elmquist, M. Otter, F.E. Cellier, *Inline Integration: A new mixed symbolic/numeric approach for solving differential-algebraic equation systems*, *ESM'95, Eur. Simul. Multiconference* (1995).
- [97] J. Kensby, A. Trüschel, J.O. Dalenbäck, Potential of residential buildings as thermal energy storage in district heating systems - Results from a pilot test, *Appl Energy* 137 (2015) 773–781, <https://doi.org/10.1016/j.apenergy.2014.07.026>.
- [98] M. Wetter, M. Bonvini, T.S. Noudiui, Equation-based languages - A new paradigm for building energy modeling, simulation and optimization, *Energy Build* 117 (2016) 290–300, <https://doi.org/10.1016/j.enbuild.2015.10.017>.
- [99] H. Lund, P.A. Østergaard, M. Chang, S. Werner, S. Svendsen, P. Sorknæs, et al., The status of 4th generation district heating: Research and results, *Energy* 164 (2018) 147–159, <https://doi.org/10.1016/j.energy.2018.08.206>.





Paper II





## A Novel Method for Designing Fifth-Generation District Heating and Cooling Systems

Marwan Abugabbara<sup>1\*</sup>, Jonas Lindhe<sup>1</sup>

<sup>1</sup> Department of Building and Environmental Technology, Division of Building Services, Lund University, Lund 221 00, Sweden

**Abstract.** District heating and cooling systems have been undergoing continuous development and have now reached the fifth-generation. In this innovative technology, connected buildings share local excess energy that otherwise would be wasted, which consequently reduces primary energy demands and carbon emissions. To date, the issue of implementing fifth-generation district systems on existing buildings has received scant attention, and our research addresses this challenging gap by proposing a novel method for designing these systems. We first explain the possible thermal interactions between connected buildings, and then present an analytical solution for the network energy balance, pipe design, and the prediction of fluid temperature under a fixed temperature difference control strategy. The analytical solution was validated against numerical simulations performed on 11 existing buildings located in Lund, Sweden using Modelica models. A diversity index metric between heating and cooling demands was also included in these models to assess the efficiency of the district system in the building cluster. The results from the analytical and numerical solutions were in complete agreement since Modelica is an equation-based modelling language. The developed models pave the way towards future investigations of different temperature control strategies and new business models that arise from the shift to the fifth-generation.

### 1 Introduction

The global population is expected to reach 9.7 billion by 2050 where up to 68% will reside in urban areas [1]. As a consequence of this increase in urbanisation, the number of households is expected to grow by 70% [2]. One of the major challenges for future urban areas is to efficiently supply buildings with the required thermal energy. District Heating and Cooling (DHC) systems are an effective technology and considered most feasible in urban areas with high heat density [3]. Compared to their counterparts, DHC systems have high resilience to integrating renewable energy sources that would increase energy efficiency and reduce carbon emissions.

District heating networks have been widely used since their first implementation in the 1860s in New York, USA. The latest figures show that there are about 80,000 district heating systems around the world with a total pipe length of about 600,000 km [4]. The European market has a share of 6,000 systems and a pipe length of 200,000 km. According to Werner [4], district cooling networks were introduced at a later stage compared to district heating networks. The first district cooling network was realized in Hartford, USA in 1962 and in Hamburg, Germany in 1967. Due to their higher security of supply and low carbon emissions, the implementation rate of DHC networks exceeds 50% in some countries like in Denmark and Sweden.

The basic idea of district heating networks is to generate heat and supply it to connected buildings through distribution pipes. The heat generation usually

happens at a central heat production plant, e.g., boilers or combined heat and power plant. A heat carrier, typically water, delivers the heat to the end customer through the pipe network. At the customer level, the heat is exchanged between two fluid streams. The first of these is the fluid in the distribution pipe and the second is the fluid that circulates heat to the different radiators inside the building. A similar mechanism applies to district cooling, but for the purpose of heat extraction. The technology has evolved through several generations in order to improve energy efficiency.

The first generation used steam as a heat carrier, which due to the risk of explosions was replaced by water and led to the inauguration of the second generation [5]. The water was delivered at a temperature of about 100 °C and had to be lowered when buildings started to become more energy efficient. The reduction of water temperature to 80 °C marked the introduction of the third generation, which is also known as the Scandinavian district heating networks [4]. Due to problems with high thermal distribution losses, the fourth generation allowed a significant temperature reduction to about 50 °C without affecting the security of heat supply. Despite the high efficiency the fourth generation achieves, the network, nevertheless, has a centralized heat production and cannot provide simultaneous heating and cooling.

The fifth-generation district heating and cooling (SGDHC) system addresses the previous issues by offering the following two solutions. First, the network operates at temperatures close to the ground

\* Corresponding author: [marwan.abugabbara@hvac.lth.se](mailto:marwan.abugabbara@hvac.lth.se)

temperature. Local heat pumps and chillers in each building modulate the temperature to the required levels. This results in lower distribution losses and facilitates network expansion due to decentralized heat production. The second solution is related to sharing local excess heat from one building to another. For example, chillers pump water from the network to provide cooling to the building. At the same time, they reject heat that is injected back to the network and shared with other buildings. This means that the water flows through a bidirectional pipe network that provides simultaneous heating and cooling.

In order to achieve the highest system efficiency, buildings connected to a 5GDHC network need to be balanced in terms of their requirements for simultaneous heating and cooling. Typical examples of buildings with heating demands are residential and service buildings. On the other hand, data centres require cooling throughout the year. Buildings with simultaneous requirements for heating and cooling are exemplified in hospitals. Most of the documented projects with 5GDHC networks have been realised in Switzerland. Examples of these projects are ETH Zurich campus Honggerberg [6] and Suurstoffi district in Rotkreuz [7]. Each of these networks connects different buildings with different heating and cooling demands, which makes it difficult to assess the efficiency of the system at the early design stage when a new project with different buildings is launched.

Thus, the need for a robust tool that identifies potential building clusters that can be connected to the 5GDHC networks becomes increasingly important, in light of the difficulty with the assessment. Previous work by Zarin Pass et al. resulted in the development of the metric diversity index for assessing promising building clusters [8]. We build on the work of Zarin Pass et al. by developing a Modelica-based tool for designing any 5GDHC network including the calculation of the diversity index. Modelica is being warmly received by the world community for modelling complex physical systems [9] and continues to show promising prospects within modelling of district energy systems [10].

The objective of this paper is to demonstrate a novel method for designing the 5GDHC systems. Section 2 of this paper presents the system architecture, the analytical solution for designing the system, and a case study comprising eleven buildings. Section 3 illustrates and discusses the results of the simulations performed on the case study. Finally, conclusions and future work are outlined in Section 4.

## 2 Method

The design of 5GDHC systems can depend on different strategies and several system configurations. This section describes the developed design method for 5GDHC systems with installed heat pump and chiller at the building level. Firstly, the system components and thermal interactions between connected buildings are described. Secondly, an analytical solution is proposed to enable modelling the system using the equation-based

Modelica language. Thirdly, an assessment metric for clustering buildings is introduced. Lastly, a case study is presented in order to implement the design method and validate the analytical solution.

### 2.1 System architecture and thermal interactions

To throw more light on the different thermal interactions between connected buildings in a fifth-generation district heating and cooling network, consider the depicted building cluster in Figure 1. In this example, three buildings are connected to the network: a data centre building with only cooling demands; a residential building with only heating demands; and an industrial or a hospital building with simultaneous demands for heating and cooling. Each building extracts and/or rejects heat from/to the network according to its requirement for thermal energy. The substation room denoted as SR contains the installed heat pump (HP) and chiller (CH) that modulate the temperatures to the required supply levels. These components can be replaced by a combined cool- and heat pump in other system configurations. In this study, we present a system with separate heat pump and chiller for the production of heating and cooling, respectively. The network can be easily expanded to connect more buildings in an urban area. The last component in the network is the balancing unit (BU) that is responsible for injecting heat to the network in the case of heat deficit, or discharging heat out from the network in the case of excess heat.

From Figure 1 we may elicit the following three main scenarios of thermal interactions taking place in the network. The first scenario considers buildings with only heating demands, such as the residential building. Here, the building requires heating that is first delivered by any rejected heat from other buildings connected to the network ( $Q_{rej}$ ). If these are absent, the balancing unit injects the required heat to the network and the residential building extracts it from the network ( $Q_{in}$ ). In the second scenario the process of delivering only cooling is described herein, as in the data centre building. The chiller in the building's substation room produces the required cooling, which results in a heating by-product in the chiller's condenser side. This heating is rejected to the network and distributed to other buildings that require heating. If such demands for heating in other buildings cease to exist, the energy is stored inside the balancing unit.

The third scenario can adapt different design configurations depending on the type of the installed heating and cooling units. We present the case where a heat pump and a chiller are both installed at the building level. In this scenario, simultaneous heating and cooling are required in the building, such as in the industrial building. Depending on whether heating or cooling is dominant, the corresponding heat pump or chiller delivers the required energy. The heat pump and chiller are connected at the inlets and outlets in order to exchange energy between them, as shown in the magnifying glass in Figure 1. The extracted or rejected

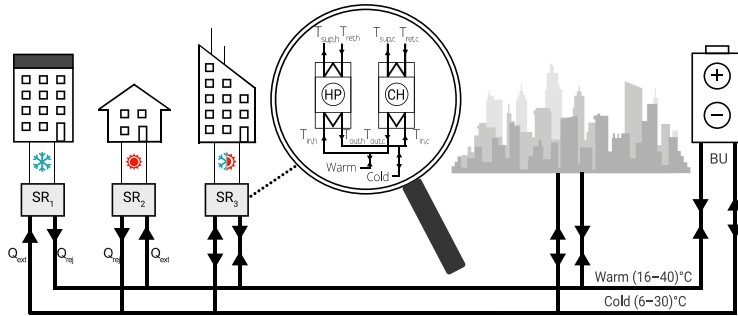

**Fig. 1.** Illustration of an abstract building cluster in a fifth-generation district heating and cooling system. SR denotes the substation room, BU represents the balancing unit,  $Q_{ext}$  and  $Q_{rej}$  refers to the extracted and rejected heat, while  $T_{sup,h}$ ,  $T_{ret,h}$ ,  $T_{sup,c}$ , and  $T_{ret,c}$  represents the space heating/cooling supply and return temperatures.  $T_{in,h}$ ,  $T_{out,h}$ ,  $T_{in,c}$ , and  $T_{out,c}$  describe the inlet/outlet temperatures in the heat pump and chiller.

energy is then derived as explained in scenario 1 and 2, depending on the dominant category. In case the rejected energy to the network exceeds the capacity of the balancing unit, cooling towers are installed to discharge the heat from the network. As more buildings become connected to the network, the previous laws of conservation are repeated until the sum of all flows of energy at a certain point in the closed network is equal to zero.

## 2.2 Analytical solution

To enable modelling and simulation of 5GDHC systems using the equation-based Modelica language, an analytical solution has been developed and is presented thoroughly in this section.

### 2.2.1 Network energy balance

A typical fifth-generation district heating and cooling network reaches an energy balance according to the synergetic thermal interactions between the connected buildings and the balancing unit. The energy balance is achieved through the following three stages: 1) intra-balancing, 2) inter-balancing, and 3) network balancing. These stages are explained below together with their mathematical derivation.

**Stage 1.** The heating and cooling demands for an individual building are balanced against each other. The building can have either a separate heat pump and chiller to provide heating and cooling, or a combined cool- and heat pump that provides simultaneous heating and cooling at the evaporator and condenser sides, respectively. The design principle for the two strategies is the same. As mentioned earlier, this paper presents the case where a separate heat pump and chiller are installed in the substation room.

For a building with heating and cooling demands denoted as  $Q_h$  and  $Q_c$ , only one unit between the heat pump and the chiller is first operated independently. The electrical power  $P_{el}$  is then calculated as shown in Equation 1, where  $COP$  is the coefficient of performance of the operated unit.

$$P_{el} = \min \frac{Q_h/COP}{Q_c/(COP - 1)} \quad (1)$$

The heating power at the condenser side  $P_h$  and the cooling power at the evaporator side  $P_c$  of the operated unit are derived in Equations 2 and 3.

$$P_h = P_{el} \cdot COP \quad (2)$$

$$P_c = P_{el} \cdot (COP - 1) \quad (3)$$

In an ideal scenario, the building's heating and cooling demands are balanced against each other at this stage. If the delivered heating and cooling power from the operated unit do not match the building demands, the remaining required heating or cooling are provided from the other buildings connected to the network and described in the next stage.

**Stage 2.** The balancing between the connected buildings occurs at this stage. The remaining heating requirement for an individual building  $Q_{h,req}$  is described as the difference between the building heat demands and the heating power provided by the operated unit, as shown in Equation 4.

$$Q_{h,req} = Q_h - P_h \quad (4)$$

At this point, the heat pump provides the required heating by extracting heat  $Q_{ext}$  that is pumped at the heat pump evaporator side. The extracted heat is represented in Equation 5 as follows:

$$Q_{ext} = Q_{h,req} - (Q_{h,req}/COP) \quad (5)$$

Similarly, the required cooling demands for an individual building are represented in Equation 6.

$$Q_{c,req} = Q_c - P_c \quad (6)$$

The chiller provides the required cooling and, simultaneously, rejects excess heat from its condenser side into the network. The rejected excess heat  $Q_{rej}$  is represented as:

$$Q_{rej} = \frac{Q_{c,req}}{COP - 1} \cdot COP \quad (7)$$

If the total extracted heat is not equal to the rejected heat from all connected buildings, a final balancing stage is therefore required.

**Stage 3.** A network balancing unit is employed and has primarily two functions. First, it injects energy to the network in case the total extracted heat by the connected buildings exceeds the available energy in the network. This energy can be delivered from an energy source such as air-source or ground-source heat pumps. The quantity of injected energy  $Q_{inj}$  is equivalent to:

$$Q_{inj} = Q_{ext} - Q_{rej} \quad (8)$$

Conversely, when the total rejected heat from the connected buildings are greater than the extracted heat, the balancing unit finally exhausts the excess energy out from the network. The exhausted energy  $Q_{exh}$  is represented in Equation 9 as follows:

$$Q_{exh} = Q_{rej} - Q_{ext} \quad (9)$$

### 2.2.2 Pipe design

In order to size the branch warm and cold pipes at each building, the following analytical solution has been developed. The evaporator cold side of the heat pump represents the extracted energy and is connected to the cold pipe. This configuration can be seen in the illustration presented in Figure 1. The mass flow rate in the cold pipe  $\dot{m}_{col}$  is defined as:

$$\dot{m}_{col} = \frac{Q_{ext}}{c_{p,water} \cdot \Delta T} \quad (10)$$

Similarly, the mass flow rate in the warm pipe  $\dot{m}_{war}$  is defined as:

$$\dot{m}_{war} = \frac{Q_{rej}}{c_{p,water} \cdot \Delta T} \quad (11)$$

The diameter of the cold and warm pipes can now be determined as described in Equations 12 and 13.

$$D_{col} = \sqrt{\frac{4 \left( \frac{\dot{m}_{col}}{\rho \cdot v} \right)}{\pi}} \quad (12)$$

$$D_{war} = \sqrt{\frac{4 \left( \frac{\dot{m}_{war}}{\rho \cdot v} \right)}{\pi}} \quad (13)$$

### 2.2.3 Fluid temperature

The mass flow rates in the cold and warm pipes determine the change of the network fluid temperature. The fluid temperature decreases when energy is extracted from the network. On the contrary, the temperature increases when heat is rejected into the network. The network temperature is controlled and bound between low and high temperature limits. The decreasing temperature  $T_{dec}$  is defined as:

$$T_{dec} = \begin{cases} \max \left( T_{fluid} - \frac{\Delta T \cdot \dot{m}_{col}}{Volume}, T_{low} \right) & \text{if } \dot{m}_{col} > 0 \\ 0 & \text{otherwise} \end{cases} \quad (14)$$

where  $T_{fluid}$  is the grid temperature and assumed equal to  $T_{low}$  at the start of simulation,  $Volume$  is the total grid volume in  $m^3$  including pipes and the storage tank,  $T_{low}$  is the pipe network lowest controlled temperature.

Analogously, the increasing temperature is controlled according to the highest network temperature  $T_{high}$  and is described as:

$$T_{inc} = \begin{cases} \min \left( T_{fluid} + \frac{\Delta T \cdot \dot{m}_{war}}{Volume}, T_{high} \right) & \text{if } \dot{m}_{war} > 0 \\ 0 & \text{otherwise} \end{cases} \quad (15)$$

The fully mixed fluid temperature is then derived as:

$$T_{fluid} = \max \left( T_{inc}, T_{dec} \right) \quad (16)$$

The previous analytical solution presented in Section 2.2 was validated against numerical simulations performed in Modelica, where the results of the simulations are presented in Section 3.

## 2.3 Assessment metric

Fifth-generation DHC systems are deemed only feasible when there is simultaneous demands for heating and cooling within the building cluster. The ratio between heating and cooling determines the amount of heat flow shared between buildings. Such a ratio can be derived using the diversity index suggested by Salat [11] and used in a previous study by Zarin Pass et al. [8] to search for promising building clusters in an urban environment. The diversity index for a building cluster varies between 0 and 1, where 1 is complete balance of diversity and 0 is complete dominance of one category. Let  $C$  be the number of categories and  $P_i$  is the frequency of occurrence of each category  $i$ , the diversity index  $div$  can then be derived as follows:

$$div = \frac{C}{C-1} \left[ 1 - \sum_{i=1}^C P_i^2 \right] \quad (17)$$

In a building cluster there are typically two categories of thermal demands, namely, heating and cooling. An ideal balance between heating and cooling depends on the heating coefficient of performance  $COP_{heat}$ . For a system with direct free cooling, as shown in the connection between the heat pump and chiller in Figure 1, ideal thermal balance occurs when:

$$Q_c = Q_h \left(1 - \frac{1}{COP_{heat}}\right) \quad (18)$$

where  $Q_c$  and  $Q_h$  denotes the respective building cooling and heating demands. The hourly diversity index  $div_h$  can now be determined between heating and cooling categories in a cluster of buildings with  $n$  number of buildings by combining Equations 17 and 18 and reformulating them as:

$$div_h = 2 \left[ 1 - \left( \frac{\sum_{i=1}^n Q_c}{\sum_{i=1}^n Q_c + \sum_{i=1}^n Q_h \left(1 - \frac{1}{COP_{heat}}\right)} \right)^2 - \left( \frac{\sum_{i=1}^n Q_h \left(1 - \frac{1}{COP_{heat}}\right)}{\sum_{i=1}^n Q_c + \sum_{i=1}^n Q_h \left(1 - \frac{1}{COP_{heat}}\right)} \right)^2 \right] \quad (19)$$

To facilitate the assessment of potential building clusters, an annual average of the hourly diversity  $div_{annual}$  is weighted by the total hourly energy use in the cluster and expressed as:

$$div_{annual} = \frac{\sum_{h=1}^{8760} div_h |Q_{tot,h}|}{\sum_{h=1}^{8760} |Q_{tot,h}|} \quad (20)$$

where  $h$  represents the hour, 8760 is the total number of hours in a year, and  $|Q_{tot,h}|$  is the absolute sum of magnitude of all heating and cooling demands in a given hour with positive sign for both heating and cooling.

### 2.4 Case study

The developed analytical solution was validated numerically using Modelica simulations. The simulations involved sizing a 5GDHC network connecting 11 buildings located in Lund, Sweden. The map of the buildings is shown in Figure 2 together with the location of the balancing unit that consists of an air-source heat pump and a thermal energy storage implemented as a cylindrical water accumulator. The annual energy demands in the facility are 11 and 4 GWh for heating and cooling, respectively. The total floor area of the buildings is about 110,000 m<sup>2</sup> with different space use for offices, labs, conferences, restaurants, and a sport centre. The pipe network is currently under construction and the installation is progressing in different construction phases. The map in Figure 2 shows the completed construction phase one represented by the dashed red line. All buildings will be connected to the network at the end of the construction work.

The network design parameters for the reference design case are shown in Table 1. The parameters can be later adjusted in order to optimise both the design and the operation of the network. At the initial design stage, it was assumed that the 5GDHC network will operate simultaneously next to the traditional district system that is already connected to the buildings. The traditional system covers the domestic hot water demands and the peak loads that exceed the capacity of the heat pumps and chillers. The benefit of this approach is the significant reduction in investment costs. When the heat pumps and chillers are sized with a capacity of about



Fig. 2. Map of the eleven buildings included in the case study. The map was created using QGIS program for the analysis of geospatial data.

half the building's peak loads, the 5GDHC network covered 89 and 93% percent of the annual heating and cooling energy, respectively. By maintaining the connection between the buildings and the traditional district system, a security of supply is ensured throughout the year, while keeping the network investment cost minimal. Another design assumption was to consider the demands in building 10 as an archetype of building 7. Building 10 was under construction and the acquisition of measured or simulated data was not possible. Since buildings 10 and 7 have almost the same space use and type of operation, this assumption allows to include the new building's demands in the design of the network.

Table 1. Design parameters for the reference case.

Parameter	Value	Unit
Network temperature difference ( $\Delta T$ )	10	K
Network lowest temperature	6	°C
Network highest temperature	40	°C
Fluid maximum velocity	1	m/s
Storage tank volume	150	m <sup>3</sup>

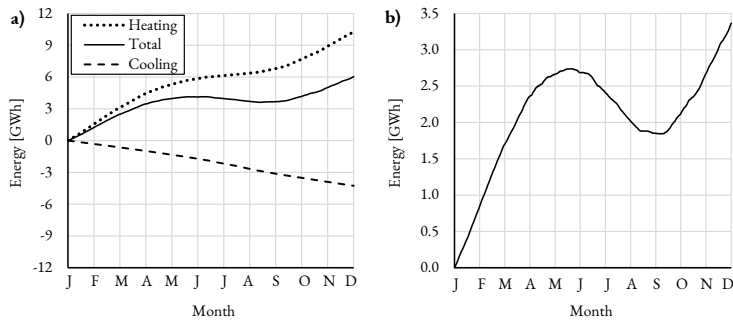

Fig. 3. Cumulated energy demands in the building cluster (a), cumulated energy provided by the balancing unit (b).

### 3 Results and discussion

The validation of the analytical solution and the results of the Modelica simulations performed on the case study are presented in this section. Because the behaviour of physical models developed in Modelica is described by differential algebraic equations, the results from the Modelica simulations were in complete agreement with the analytical solution. The annual Modelica simulations were performed using the DASSL integration algorithm with a  $10^{-4}$  tolerance. The energy demands and the detailed analysis of the diversity index are introduced in section 3.1. The network fluid temperature is then presented with a discussion on the effect of a fixed temperature difference control strategy.

#### 3.1 Energy balance and load diversity

Referring to the case study described in Section 2.4, the cumulated energy demands in the cluster including all eleven buildings are shown in Figure 3(a). As is evident, the cluster has simultaneous demands for heating and cooling throughout the year. The cooling demands are increasing steadily as represented in the dashed line. On the other hand, the dotted line shows that the demands for heating are lowest during summer. The summer demands for heating are used only for space heating since the demands for hot tap water were not included in this study. The annual energy demands in the cluster are about 11 and 4 GWh for the respective heating and cooling. The simultaneous requirement for heating and cooling increases the potential for more load diversity within the cluster where energy can be shared within and between the buildings throughout the year.

The cumulated annual energy provided by the balancing unit is shown in Figure 3(b). To enhance appearance, note that the two figures do not have a uniform scale. Figure 3(b) provides an understanding of the energy balance in the cluster. Comparing these two figures, it can be seen that the balancing unit

continuously injects energy to the network during the cold season when the demands for heating exceed the demands for cooling, as seen in the positive slope of the line in Figure 3(b). Conversely, when cooling demands dominate during the summer season, the network is charged with excess heat that results from the cooling process. In this case, the balancing unit starts to discharge the excess heat out from the network, which is represented by the negative slope of the line during summer. To increase the efficiency of the system, the amount of excess heat should be minimised. This can be realised by analysing the load diversity in each building in order to assess how each building contributes to the different demands for heating and cooling.

Figure 4 shows the contours of the diversity index for each building individually and when the building is paired, i.e., clustered, with only one other building. At first glance, one can see that there are three kinds of building combinations that have no diversity at all and are coloured in dark blue. These are buildings 3, 8 and the cluster combining these two buildings. Whilst these

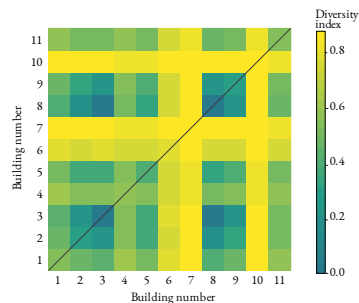

Fig. 4. Symmetric contour map of the diversity index for the individual buildings.



results indicate zero load diversity, they do not reveal much about whether heating or cooling is the dominant category. At the other end of the spectrum, buildings 7 and 10 prove to serve as efficiency gains since the diversity index was improved in all their possible cluster combinations. As reported in [8], district systems are also built for the purpose of increasing community resilience and not only efficiency. For this purpose, we carried out a sensitivity analysis on the effect of each individual building on the diversity of the cluster covering all eleven buildings. The analysis not only considered the building as one block, but also considered whether heating or cooling demands are excluded from being covered by the network.

Figure 5 demonstrates the effect of excluding certain parts of the building on the diversity index. The annual diversity index for the cluster including both heating and cooling for the eleven buildings was 0.78. Due to the dominant cumulated demands for heating throughout the year, excluding heating in an individual building yields a better load diversity within the cluster. On the contrary, excluding cooling demands has more negative consequences on the diversity between loads. Once again, the results confirm the importance of some buildings on the performance of the system. Excluding buildings 6, 7, and 10, especially their cooling demands, plummeted the annual diversity five times lower than the average of the other buildings. This result opens the possibilities for more flexible scenarios during the early design of 5GDHC systems. Instead of connecting buildings to the network as one block, only one category of thermal demands can be supplied by the network to maximise its efficiency. The excluded part of thermal demands can be covered by local auxiliary systems.

The analysis of the diversity index does not provide insights on how different clusters can be formed by the same number of buildings. A tool that can perform exhaustive searches through combination and permutation of buildings is required in order to assess the impact of several clustering possibilities.

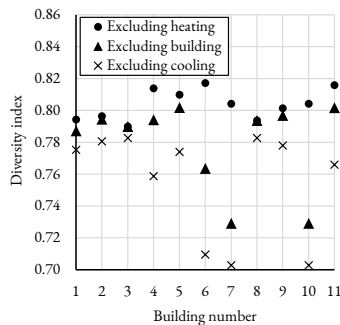

Fig. 5. Variations of the diversity index for different design scenarios. Annual diversity index for the cluster including all eleven buildings is 0.78.

### 3.2 Fluid temperature oscillation

The fluid temperature oscillation in the pipes shown in Figure 6 provides an explanation of the different thermal processes happening in the system. For instance, the buildings extract energy from the network during cold months due to the dominant requirements for space heating. In spring, the requirements for space cooling starts to dominate, causing the buildings to inject energy to the network, which in return causes the network temperature to rise. At this point, the thermal storage tank starts to accumulate the excess energy and stores it for later use. As the demands for cooling keep rising during summer months, the network temperature reaches its maximum design temperature, and the tank reaches its maximum storage capacity. When the excess energy can no longer be utilised, the balancing unit discharges it out from the network. This process can also be seen by comparing Figure 6 with the negative slope of the line in Figure 3(b). Both charts confirm that the excess energy is not utilised between June and mid-August. A consideration of the temperature oscillation indicates that the network temperature is cold in winter when it is supposed to be warm, and it is warm in summer when it is supposed to be cold. This confirms the findings in [12] where a free-floating temperature of the warm line setpoint produced a similar behaviour. The authors in [12] attempted to optimise the warm line setpoint temperature in order to increase the performance of the heat pumps due to the dominating heating in winter. The different temperature control strategies require further research during the future development of the model developed in this study.

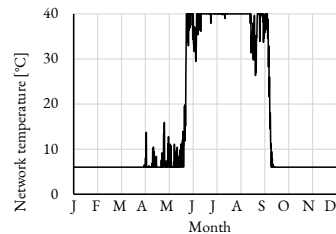

Fig. 6. Hourly fluid temperature oscillation in the pipes throughout the year.

### 4 Conclusions

The current study demonstrated a novel method for designing any fifth-generation district heating and cooling system. The models used for the design were developed using the Modelica language and they are under continuous improvement. We utilised the models to cluster eleven buildings located in Lund, Sweden and presented the different thermal interactions taking a place in the cluster. An analytical solution was developed and validated against the numerical Modelica simulations. The diversity index was also evaluated in

the models for each individual building and for the cluster combining all buildings in order to understand and improve the diversity between heating and cooling demands.

From the analysis carried out on the case study, we conclude the following three main points. First, fifth-generation district heating and cooling systems can be implemented in existing buildings to cover a primary base load of up to 90% of the annual heating and cooling demands. The peak loads are covered by conventional heating and cooling systems with minimal annual operating hours. The advantages of this approach are the reduced investment cost, the added flexibility in network expansion, and the ability to connect buildings with different low and high temperature requirements. Second, fifth-generation district systems allow covering only one side of the building's heating or cooling demands from the network. Such configuration can increase the system efficiency whilst it opens possibilities for new business models. Third, future work requires the investigation of different temperature control strategies, such as a free-floating setpoint of the warm or cold pipeline.

**Nomenclature**

- $Q$  Heating or cooling demand [W]
- $P$  Thermal or electrical power [W]
- $\dot{m}$  Mass flow rate [Kg/s]
- $\Delta T$  Temperature difference [K]
- $D$  Diameter [m]
- $\rho$  Water density [kg/m<sup>3</sup>]
- $v$  Fluid velocity [m/s]

**References**

[1] United Nations, "World population prospects: the 2017 revision, key findings and advance tables," *Dep. Econ. Soc. Aff. PD, Ed. New York United Nations*, 2017.

[2] P. IEA, "Energy technology perspectives 2012: Pathways to a clean energy system." International Energy Agency Paris, 2012.

[3] S. Amiri and G. Weinberger, "Increased cogeneration of renewable electricity through energy cooperation in a Swedish district heating system - A case study," *Renew. Energy*, vol. 116, pp. 866–877, 2018.

[4] S. Werner, "International review of district heating and cooling," *Energy*, 2017.

[5] M. Pellegrini and A. Bianchini, "The innovative concept of cold district heating networks: A literature review," *Energies*, vol. 11, no. 2, 2018.

[6] "Anergy grid ETH Zurich." [Online]. Available: <https://ethz.ch/en/the-eth-zurich/sustainability/campus/environment/energy/anergy-grid.html>. [Accessed: 15-May-2020].

[7] A. Prasanna, V. Dorer, and N. Vetterli, "Optimisation of a district energy system with a low temperature network," *Energy*, vol. 137, pp. 632–648, 2017.

[8] R. Zarin Pass, M. Wetter, and M. A. Piette, "A thermodynamic analysis of a novel bidirectional district heating and cooling network," *Energy*, vol. 144, pp. 20–30, 2018.

[9] P. Fritzon, *Principles of object-oriented modeling and simulation with Modelica 2.1*. IEEE, 2004.

[10] M. Abugabbara, S. Javed, H. Bagge, and D. Johansson, "Bibliographic analysis of the recent advancements in modeling and co-simulating the fifth-generation district heating and cooling systems," *Energy and Buildings*, vol. 224. Elsevier Ltd, 01-Oct-2020.

[11] S. Salat, F. Labbé, C. Nowacki, and G. Walker, *Cities and Forms: on sustainable urbanism*. 2011.

[12] F. Bünnig, M. Wetter, M. Fuchs, and D. Müller, "Bidirectional low temperature district energy systems with agent-based control: Performance comparison and operation optimization," *Appl. Energy*, vol. 209, no. October 2017, pp. 502–515, 2018.

Paper III





---

The 17<sup>th</sup> International Symposium on District Heating and Cooling, Nottingham Trent University,  
6–9 September 2021, Nottingham, United Kingdom

## Modelica-based simulations of decentralised substations to support decarbonisation of district heating and cooling

Marwan Abugabbara<sup>1,\*</sup>, Jonas Lindhe<sup>1</sup>, Saqib Javed<sup>1</sup>, Hans Bagge<sup>2</sup>, Dennis Johansson<sup>1</sup>

<sup>a</sup> Department of Building and Environmental Technology, Division of Building Services, Lund University, Lund 221 00, Sweden

<sup>b</sup> Department of Building and Environmental Technology, Division of Building Physics, Lund University, Lund 221 00, Sweden

---

### Abstract

District heating and cooling are considered effective solutions to decarbonise the energy use in the building sector. The latest generation of district heating and cooling also increases the potential of integrating heat pumps and chillers in each building substation. The benefits of such integration are the reduction of network temperature and distribution losses; the recovery of waste heat through a bidirectional network; and the decentralised production of heating and cooling. Sizing the network depends mainly on the heat flows between connected buildings. The substation performance and technical installations determine these heat flows. We present in this paper Modelica-based simulations of two design cases for substations. The first design case involves installed heat pump, chiller, and circulation pumps. Alternatively, the second design enables the heat pump to provide direct cooling through a heat exchanger. The models for these installations were developed using the Modelica language to perform continuous-time simulations. The performance in each design case was evaluated in terms of seasonal coefficient of performance and total electric energy use. An analysis on a cluster of 11 buildings suggests that the addition of the direct cooling heat exchanger can save up to 10% of the total annual electric energy use. Additional savings can be achieved by optimising the building supply temperatures and the district network temperature.

*Keywords:* Heat pumps; waste heat recovery; 5GDHC; Modelica

---

### 1. Introduction

The new goals in the Swedish Climate Policy Framework adopted in 2017 aim at reaching zero net emissions of greenhouse gases by 2045 [1]. The country has also a promising target to achieve 100% renewable electricity production by 2040 [2]. To attain these goals, innovative solutions in different sectors are necessary. Heating and cooling of residential and commercial buildings account for almost 40% of the total final energy use in Europe and in Sweden [3]. This figure shows that there is a possibility to improve the energy-efficiency within the building sector. Waste heat recovery, security of supply, efficient heat distribution, and competitive price strategies are some of the current questions researchers attempt to address to improve energy-efficiency.

District heating and cooling (DHC) are considered effective solutions to decarbonise the building sector and can help reaching national and international energy-efficiency targets [4]. The systems are a common way for heating and cooling buildings in urban areas with an implementation rate exceeding 50% in Sweden, Denmark, Finland, Russia, and northern China [5]. Regardless of their popularity, conventional DHC systems have two main drawbacks. First, the centralised heat production results in higher distribution losses through the pipe network. Second, separate pipes are required for the supply of simultaneous heating and cooling. A possible solution to these problems is the integration

---

\* Corresponding author. Tel.: +46 730 72 75 26  
E-mail address: marwan.abugabbara@hvac.lth.se

of heat pumps and chillers in each building substation. The term *substation* refers to the link between the building side and the district network. A typical substation in a fifth-generation district heating and cooling (5GDHC) system mainly consists of a heat pump, chiller, circulation pumps, and heat exchanger for direct cooling. The outcomes of decentralised substations are the significant reduction in network temperature, and the simultaneous supply of heating and cooling through the same pipes.

### 1.1. Design and modelling of 5GDHC systems

A typical 5GDHC system leverages the synergies between connected buildings with different thermal demands. Hence, the heat carrier in the pipe can flow in either direction depending on the type of thermal demand at a given point in time. The system mainly comprises of the following three subsystems: 1) substations with installed heat pumps and chillers to modulate the temperature to the building desired supply levels, 2) low temperature bidirectional network with uninsulated pipes, and 3) balancing unit for energy storage and heat production. Previous work that investigated this generation can be seen in the comprehensive review by Buffa et al. [6]. For system design, Wirtz et al. [7] presented a mathematical model based on linear programming for the design of bidirectional networks. Another study by Abugabbara and Lindhe [8] demonstrated an analytical solution to balance energy flows between connected buildings and to size 5GDHC networks. An important aspect that is lacking in these studies is the ability to evaluate the system performance dynamically and for different design cases. In equation-based object-oriented modelling, large complex systems are composed by assembling smaller stand-alone subsystem models. These subsystem models can be easily reconfigured to simulate the system under different design cases.

The Modelica language offers high flexibility and reusability of component models across several domains. District heating and cooling systems involve components from thermo-fluid and control domains. A recent review by Abugabbara et al. [9] motivated the choice of Modelica for modelling and simulation of complex physical systems such as the 5GDHC systems. The free open-source Modelica *Buildings Library* [10] contains validated models for building and community energy systems. We use these models to construct larger models for decentralised substations. An investigation of different design cases and their impact on the system performance was carried out and the main findings are presented in this paper.

### 1.2. Paper objective

The objective of the paper is to evaluate the performance of substation installations in different design cases. The paper attempts to study the performance of two substations with different design cases. Figure 1 presents the schematic diagram of the two considered substations. In substation A, the heat pump evaporator inlet is connected to the chiller condenser outlet to recover waste heat. Similarly, the heat pump evaporator outlet serves as a cold source to the chiller condenser inlet. Depending on the proportion between heating and cooling demands, heat is either extracted or injected from/to the bidirectional network. Substation B includes all previous installations in addition to a heat exchanger used for direct cooling. The heat exchanger reduces the electric power in the chiller's compressor. However, it decreases the potential to recover waste heat by the heat pump.

Heat pumps transfer thermal energy from a low temperature source to a higher temperature sink. The heat pump Coefficient of Performance (COP) increases to infinity when the temperature difference between sink and source approaches zero. Waste heat from the chiller raise the temperature at the heat pump source, hence, increasing the heat pump COP. Conversely, the direct cooling heat exchanger reduces the electric energy use for space cooling while also reducing the amount of recovered waste heat. We present in this paper the interactions between heat pumps, chillers, and the direct cooling heat exchanger on a cluster of 11 buildings in Lund, Sweden. The analysis was performed using Modelica continuous-time simulations where temperatures at each simulation time point were computed.

## 2. Method

This section presents the approach for modelling the substations including heat pumps, chillers, circulation pumps, and direct cooling heat exchanger. The demand profiles in the case study together with the set of used input

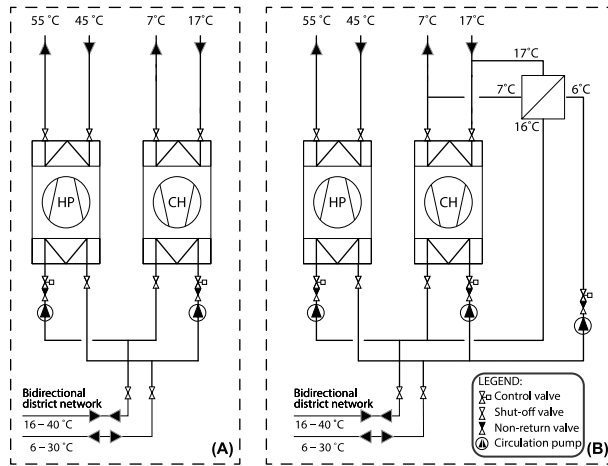

Fig. 1. Schematic diagram of a substation model with installed heat pump and chiller (A) and a substation with additional heat exchanger for direct cooling (B). Design value are presented according to the case study input parameters shown in Table 1.

parameters are then presented. The performance indicators used for evaluating the substation performance are then described. The section ends with a description of the study assumptions and limitations.

### 2.1. Models for substations

Heat pumps and chillers were modelled as a Carnot refrigerant cycle. Adjusting the COP based on the Carnot efficiency avoids favouring any particular product [11]. The COP for a heat pump and a chiller is defined as

$$COP_{HP} = \eta_{Carnot} \frac{T_{condenser}}{T_{condenser} - T_{evaporator}} \quad COP_{CH} = \eta_{Carnot} \frac{T_{evaporator}}{T_{condenser} - T_{evaporator}} \quad (1)$$

Since the physical behaviour of chillers is almost identical to heat pumps, we will only present models for heat pumps. At each simulation time point, mass flow rates at the condenser and evaporator are computed as

$$\dot{m}_{condenser} = \frac{\dot{Q}_h}{c_p \Delta T_{condenser}} \quad \dot{m}_{evaporator} = \frac{\dot{Q}_h - W_{compressor}}{c_p \Delta T_{evaporator}} \quad (2)$$

where  $\dot{Q}_h$  is the building heat demand in Watts,  $c_p$  is the water specific heat capacity in J/kg·K,  $\Delta T_{condenser}$  and  $\Delta T_{evaporator}$  are the temperature difference between condenser and evaporator inlet and outlet, and  $W_{compressor}$  is the heat pump electric power which is equivalent to

$$W_{compressor} = \frac{\dot{Q}_h}{COP_{HP}} \quad (3)$$

On the heat pump evaporator side, the circulation pump extracts water in the amount of  $\dot{m}_{evaporator}$ . The circulation pump electric power is derived as

$$W_{cirPump} = \frac{\dot{V}_{evaporator} \Delta p}{\eta_h \eta_m} \quad (4)$$

where  $\dot{V}_{evaporator}$  is the volume flow rate in  $m^3/s$ ,  $\Delta p$  is the pump pressure rise in Pa,  $\eta_h$  and  $\eta_m$  are the hydraulic and motor efficiencies of the circulation pump.

Lastly, the Carnot cycle models for heat pumps and chillers were used to construct models for substations. Figure 2 depicts the case of a substation with only heat demands and installed heat pump. Modelling systems in Modelica is realised by instantiating components and connecting them visually in a Lego-like approach. Connector lines interface component variables inside the model when seen from within, and from the outside when the component is externally connected. The right box in Figure 2 provides a description of the components in substation model with only heating demand. Fluid ports 17 and 19 represent the connection to the respective district warm and cold pipes when the model is connected from the outside. The fluid transport delay in the substation is taken into account as shown in components 16 and 18. On the heat pump evaporator cold side, the circulation pump extracts water from the warm district pipe to the evaporator inlet. The cold water at the evaporator outlet then flows to the district cold pipe. On the heat pump warm side, mass flow rates at the condenser inlet are computed in components 01 to 06 based on the building demand. The condenser outlet is connected to the building sink shown in component 08. Finally, the substation total electric power and heating demand are interfaced externally through components 14 and 15 for processing results.

## 2.2. Case study

We analysed a cluster of 11 buildings to evaluate the substation performance in both design cases. The buildings are located in Lund, Sweden and have a total heated floor area of about 110,000  $m^2$ . Most of the floor area is used for offices, conference rooms, and labs. Other space usage includes restaurants and a sport centre. To understand the demand requirements in the cluster, Figure 3 shows the yearly heating and cooling demand profiles. As clearly noticed, the cluster has simultaneous demands for heating and cooling throughout the year. The simultaneous demands increase the potential to exchange energy between connected buildings. However, the actual amount of exchanged energy depends on the COP of heat pumps and chillers. The substation and network design temperatures play an important role in determining the amount of exchanged energy within the cluster.

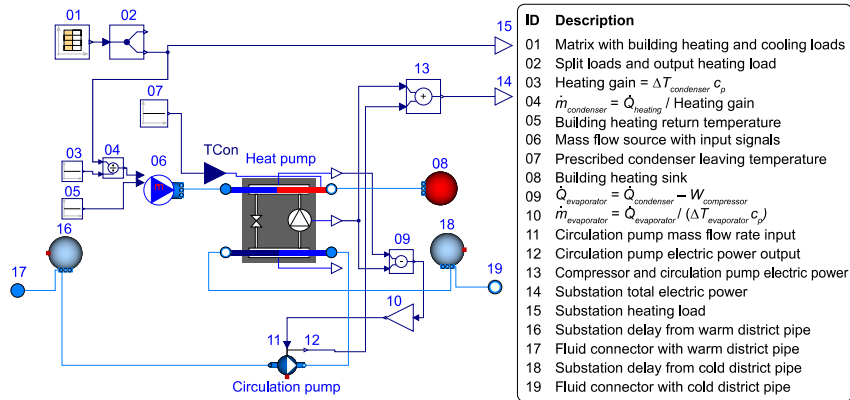

Fig. 2. Diagram view of a substation model with only heating demand. The right box describes the different components included in the model.



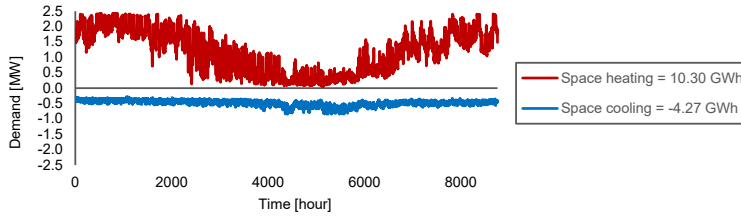

Fig. 3. Yearly heating and cooling demand profiles in the building cluster.

Table 1 provides an overview of the design parameters used in the simulations. On the district side, heating is injected to the network by the balancing unit when the warm pipe temperature drops below 16 °C. On the other hand, when the cold pipe temperature rises above 30 °C, the balancing unit supplies cooling to the network. The value of the parameter regarding water pressure drops over condenser and evaporator was chosen based on the measurements reported in [12]. The global circulation pump efficiency was set to 0.49 for the assumed efficiencies shown in the table. Both design cases were simulated using with the same design input parameters.

Table 1. Case study design input parameters.

Parameter	Value	Unit
Temperature range in warm district pipe <sup>1</sup>	16-40	°C
Temperature range in cold district pipe <sup>1</sup>	6-30	°C
Design supply temperature for space heating <sup>1</sup>	55	°C
Design supply temperature for space cooling <sup>1</sup>	7	°C
Evaporator temperature difference of the heat pump (outlet – inlet) <sup>1</sup>	-10	K
Condenser temperature difference of the chiller (outlet – inlet) <sup>1</sup>	10	K
Temperature difference between refrigerant and water outlet in condenser and evaporator	2	K
Water pressure drops over condenser and evaporator	30 000	Pa
Carnot efficiency	50	%
Pump hydraulic and motor efficiencies	70	%

<sup>1</sup>The reader is advised to refer to Figure 1 to point the design values on the schematic diagram.

### 2.3. Performance indicator

The case study was simulated for each of the two design cases presented in Figure 1. For each simulation, the system performance was assessed based on the Seasonal Coefficient of Performance (SCOP). The SCOP for heating and cooling is defined as

$$SCOP_h = \frac{\sum_i \dot{Q}_{h,i}}{\sum_i W_{compressorHP,i} + W_{hCirPump,i}} \quad SCOP_c = \frac{\sum_i \dot{Q}_{c,i}}{\sum_i W_{compressorCH,i} + W_{cCirPump,i}} \quad (5)$$

For  $SCOP_h$  in Equation 5 the  $\dot{Q}_h$  denotes the total annual delivered heating energy by heat pumps,  $W_{compressorHP}$  is the compressors total annual electric energy use in heat pumps, and  $W_{hCirPump}$  is the total annual electric energy use in circulation pumps used for heating. The compressor electric power in heat pumps and chillers is derived from Equation 3, whereas the electric power in circulation pumps is determined as shown in Equation 4. It is worth noting that in a system with direct cooling, the chiller delivers thermal energy that corresponds to the difference between the cooling demand and the transferred heat in the heat exchanger.

2.4. Assumptions and limitations

When modelling the direct cooling heat exchanger, our primary interest was to utilise the available energy in the heat pump evaporator. In practice, the heat exchanger can also draw water from the district side depending on the temperature levels in the building return and the district pipes. The study did not include the temperature control between the heat exchanger and the district pipes. Therefore, direct cooling was realised when the heat pump is in operation and by assuming that the evaporator temperature satisfies the building cooling demand. Moreover, we did not model the building side of the heat exchanger. Instead, the heat transfer rate in the heat exchanger was set to be equivalent to the heat flow in the heat pump evaporator. This approach was sufficient to model the heat exchanger and was also followed by Sommer et al. when they only modelled the district side of the heat exchanger [13].

Another assumption involved the connection points shown in Figure 1. These points indicate fluid mixing and were modelled as mixing volumes that include the substation delay. The delay refers to the time it takes for the change in temperatures to be absorbed by the system. A time constant is used to describe this first-order lag and is defined based on engineering experience. We defined a time constant of 600 seconds similar to the district examples presented in the Modelica Buildings Library.

3. Results and discussion

This section presents the substation SCOP and electric energy use in the two design cases.

3.1. Substation SCOP

The variations in the cooling and heating SCOP throughout the year are shown Figure 4. The left chart presents the performance for the design case without direct cooling, whereas the right chart shows the system performance when direct cooling is realised. At first glance, it can be noticed that both systems have somewhat a low heating SCOP. We have considered that heat pumps supply a constant temperature of 55 °C throughout the year. As a matter of fact, each heat pump adjusts the heating supply temperature based on the outdoor temperature and a control curve. The control curve varies from building to building and can be implemented into the model when provided. Including these curves mean that heat pumps would need to operate for lower temperature lifts compared to a constant supply temperature operation. This would result in an improved heat pump performance.

A discernible distinction between the two design cases is seen in the cooling SCOP. The addition of the direct cooling heat exchanger increased the annual cooling performance by about two and a half fold. Since heat pumps in this system were also utilised to provide cooling, chillers were running with much lower powers. In winter months where heat pumps covered most of the cooling demand, the compressor load in chillers was reduced. This can be seen by contrasting the cooling SCOP in both charts in Figure 4. In summer months where heat pumps operate at much lower load ratios, chillers start to run to provide the required cooling. This resulted in a rapid decrease in the cooling SCOP in the system with direct cooling. In view of the fact that the building cluster has dominant heating demand throughout the year, employing direct cooling from heat pumps is regarded more favourable.

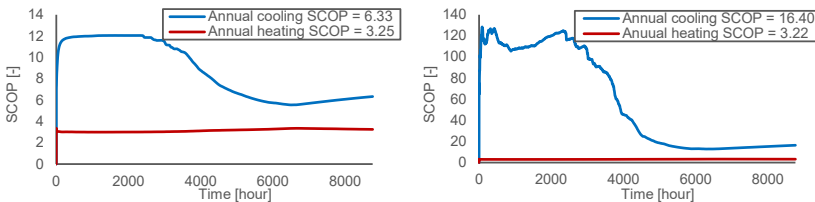

Fig. 4. Variation of heating and cooling seasonal coefficient of performance for a system with no direct cooling (left) and for a system with direct cooling (right). Note that the two charts do not have a uniform scale.

### 3.2. Substation electric energy use

Figure 5 provides a better understanding of how each design case impacted the substation annual electric energy use. The top two figures A and B compare the compressor cumulative electric energy use. For heat pumps in the two design cases, the compressor electric energy use is almost identical. This accords with the presented heating SCOP in Figure 4 since the seasonal performance was similar in the two designs. A notable difference between the two design cases is seen in chillers' electric energy use. In the first design case, chillers run continuously throughout the year to provide the required cooling demand, as shown in Figure 5(A). When direct cooling is realised, chillers only run when heat pumps can no longer fulfil the cooling demand through the evaporator ( $Q_c > Q_{\text{evaporator}}$ ). Overall, direct cooling covered the entire cooling demand during almost one third of the yearly operation. Moreover, it decreased the operating capacity of chillers which consequently reduced the compressor annual electric energy use by about 63%.

The circulation pumps electric energy use is illustrated in Figure 5(C) and Figure 5(D). The two lines representing heating and cooling circulation pumps in Figure 5(D) are superimposed on each other until a certain point. This shows that the same circulation pump is used for both heating and cooling which are provided by heat pumps. After reaching the maximum capacity of the direct cooling heat exchanger where  $Q_c > Q_{\text{evaporator}}$ , chillers start to operate. This is depicted in the diverging point in the grey line where other circulation pumps start to draw water to chillers. Taken together, the results suggest that the system with direct cooling yielded a reduction of 10% of the total electric energy use. The results, however, may differ from one building cluster to another depending on the simultaneity between heating and cooling demands. Previous studies aimed to investigate the simultaneous demands developed metrics such as the Diversity Index [11] and the Demand Overlap Coefficient [14]. Evaluating these metrics supports engineers to map potentially promising clusters in order to increase the efficiency of the district system.

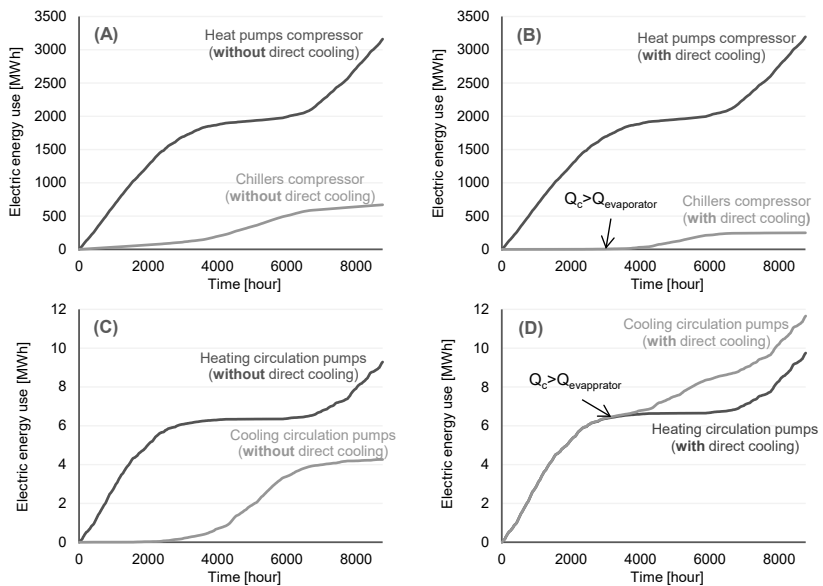

Fig. 5. Substation annual electric energy use. Figures (A) and (B) compare the electric energy use in compressors between the two design cases, while figures (C) and (D) compare the electric energy use in circulation pumps.

#### 4. Conclusions

We demonstrated in this paper Modelica-based simulations of decentralised substations with two different designs. The substations included models for heat pumps, chillers, and circulation pumps. The difference between the two designs was the utilisation of heat pumps to provide cooling from the evaporator to a direct cooling heat exchanger. We studied a cluster of 11 buildings with simultaneous heating and cooling demands to compare the two designs. The substation seasonal coefficient of performance (SCOP) and annual electric energy use were evaluated as performance indicators. The results show that the system design with direct cooling reduced the operation time of chillers by one third in addition to decreasing their operating capacity. To improve substation performance, we recommend implementing temperature controllers in both demand and supply sides. This may involve controlling the heating and cooling supply temperatures based on the outdoor weather, as well as controlling the district network temperature. The former would improve the performance of heat pumps and chillers, while the latter would increase the potential for direct cooling through the district network.

#### Acknowledgments

This work was financially supported by the Swedish Energy Agency (Energimyndigheten) under grant number 45952-1; E.ON Sverige AB; Danfoss Värmepumpar AB; Enertech AB; Lambertsson Sverige AB; NIBE Industrier AB; Qvantum Energi AB; and SKVP Info & Service AB. The first and third authors were partially funded by the European Regional Development Fund, program Interreg Öresund-Kattegat-Skagerrak, project COOLGEOHEAT. No potential conflict of interest was reported during the study.

#### References

- [1] Government Offices of Sweden. The Swedish climate policy framework 2018. <https://www.government.se/information-material/2018/03/the-swedish-climate-policy-framework/> (accessed February 17, 2021).
- [2] Agreement on Swedish energy policy 2016. <https://www.government.se/articles/2016/06/agreement-on-swedish-energy-policy/> (accessed February 18, 2021).
- [3] International Energy Agency. World energy balances and statistics 2020.
- [4] Åberg M, Fåltling L, Lingfors D, Nilsson AM, Forssell A. Do ground source heat pumps challenge the dominant position of district heating in the Swedish heating market? *J Clean Prod* 2020;254:120070. <https://doi.org/10.1016/j.jclepro.2020.120070>.
- [5] Werner S. International review of district heating and cooling. *Energy* 2017. <https://doi.org/10.1016/j.energy.2017.04.045>.
- [6] Buffa S, Cozzini M, D'Antoni M, Baratieri M, Fedrizzi R. 5th generation district heating and cooling systems: A review of existing cases in Europe. *Renew Sustain Energy Rev* 2019;104:504–22. <https://doi.org/10.1016/j.rser.2018.12.059>.
- [7] Wirtz M, Kivilip L, Remmen P, Müller D. 5th Generation District Heating: A novel design approach based on mathematical optimization. *Appl Energy* 2020;260:114158. <https://doi.org/https://doi.org/10.1016/j.apenergy.2019.114158>.
- [8] Abugabbara M, Lindhe J. A Novel Method for Designing the Fifth-Generation District Heating and Cooling Systems. *Proc. 10th Int. SCANVAC Cold Clim. Conf.* (submitted manuscript), 2021.
- [9] Abugabbara M, Javed S, Bagge H, Johansson D. Bibliographic analysis of the recent advancements in modeling and co-simulating the fifth-generation district heating and cooling systems. *Energy Build* 2020;224. <https://doi.org/10.1016/j.enbuild.2020.110260>.
- [10] Wetter M, Zuo W, Nouidui TS, Pang X. Modelica Buildings library. *J Build Perform Simul* 2014;7:253–70. <https://doi.org/10.1080/19401493.2013.765506>.
- [11] Zarin Pass R, Wetter M, Piette MA. A thermodynamic analysis of a novel bidirectional district heating and cooling network. *Energy* 2018;144:20–30. <https://doi.org/10.1016/j.energy.2017.11.122>.
- [12] Cho CW, Lee HS, Won JP, Lee MY. Measurement and evaluation of heating performance of heat pump systems using wasted heat from electric devices for an electric bus. *Energies* 2012;5:658–69. <https://doi.org/10.3390/en5030658>.
- [13] Sommer T, Sulzer M, Wetter M, Sotnikov A, Mennel S, Stettler C. The reservoir network: A new network topology for district heating and cooling. *Energy* 2020;199:117418. <https://doi.org/10.1016/j.enenergy.2020.117418>.
- [14] Wirtz M, Kivilip L, Remmen P, Müller D. Quantifying Demand Balancing in Bidirectional Low Temperature Networks. *Energy Build* 2020;224:110245. <https://doi.org/https://doi.org/10.1016/j.enbuild.2020.110245>.





Department of Building and Environmental Technology

Faculty of Engineering

Lund University

ISBN 978-91-85415-14-4

ISRN LUTVDG/TVIT-21/1004-SE(138)

ISSN 1652-6783

